

SCANCLIMBER® LT500 Lifting table

LT500

MAKES MATERIAL LIFTING EASY



Advantages:

- easily movable
- adjustable outriggers for irregular ground
- wheels for horizontal moving
- railings on all sides
- loading bridges on both sides

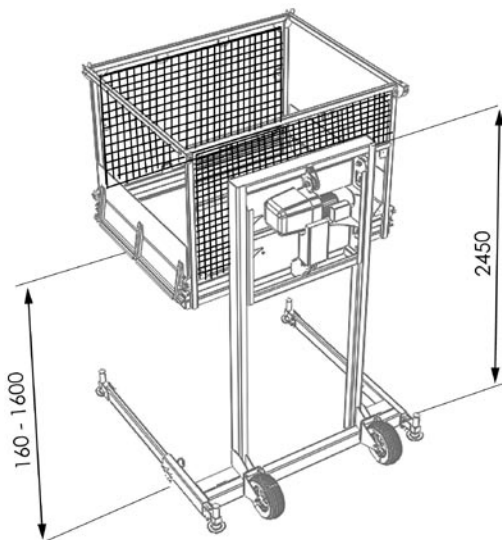

V04_04.06

TECHNICAL DATA LT500

Capacity

- Loading capacity 500 kg
- Lifting height 160 - 1600 mm

Technical measures and weights

- Table l x w 1600 x 1200 mm
- Railing height 1100 mm
- Weight (without chain winch) 369 kg

Electrical data

- Power supply 400 VAC
3-phase +N+PE socket CCE 16 Amp

Technical data of electrical chain winch, optional

- Power supply 400 VAC, 50 Hz
- Motor power 0,8 kW
- Current 1,77 A
- Lifting speed 0,1 m/s

OY SCANINTER NOKIA LTD

Turkkirata 26
FI-33960 PIRKKALA, FINLAND
Tel. +358 10 680 7000 Fax +358 10 680 7033
www.scanclimber.com