

**SCANCLIMBER®**

# Lifting table LT500

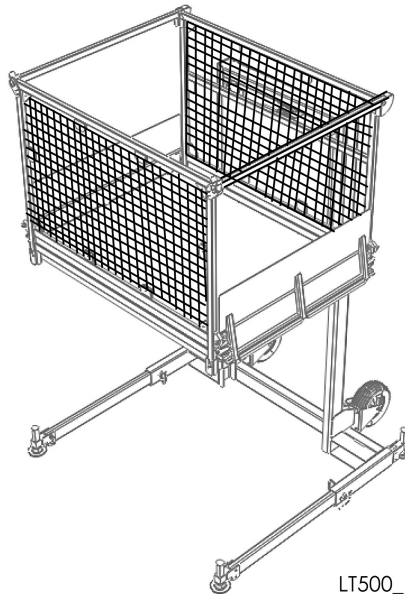

---

## INSTRUCTION MANUAL

---

**LT500** SERIAL NO: \_\_\_\_\_

---

**OY SCANINTER NOKIA LTD**

• Turkkirata 26 • FI-33960 PIRKKALA, FINLAND •  
• TEL. +358 10 680 7000 • FAX. +358 10 680 7033 •

---

V24\_06.04

---



## TABLE OF CONTENTS

LIFTING TABLE **LT500** .....

**1. General information ..... 3**

**2. Technical data ..... 4**

2.1 Capacity .....4

2.2 Technical measures and weights.....4

2.3 Electrical data .....4

2.4 Technical data of electrical chain winch, optional.....4

**3. Components..... 5**

**4. Instruction and warning decals..... 6**

**5. Electric drawing ..... 8**



## LIFTING TABLE **LT500**

### 1. General information

The lifting table **LT500** can be used for transporting material to a height of 0,3 - 1,6 meters. The maximum load capacity is 500 kg.

The lifting table is set to a desired position with jacks (4). The loading procedure is carried out through a loading bridge. The table is lifted up and lowered with an electrical chain winch (optional).



**DO NOT ENTER UNDER THE LIFTING TABLE**



**PERSONNEL TRANSPORT IS FORBIDDEN ON THE LIFTING TABLE**

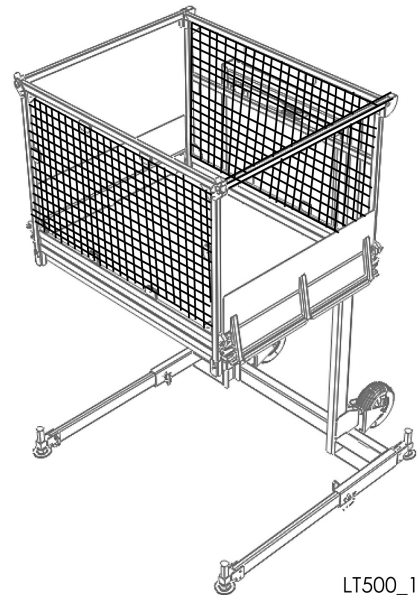

## 2. Technical data

### 2.1. Capacity

Loading capacity	500 kg
Lifting height	300 - 1600 mm

### 2.2. Technical measures and weights

Table l x w	1600 x 1200 mm
Railing height	1100 mm
Weight (without chain winch)	369 kg

### 2.3. Electrical data

Power supply 3- phase +N+PE , socket CCE	400 VAC 16 Amp
---	-------------------

### 2.4 Technical data of electrical chain winch, optional

Power supply	400 VAC, 50 Hz
Motor power	0,64 kW
Current	1,14 A
Lifting speed	0,1 m/s

## 3. Components

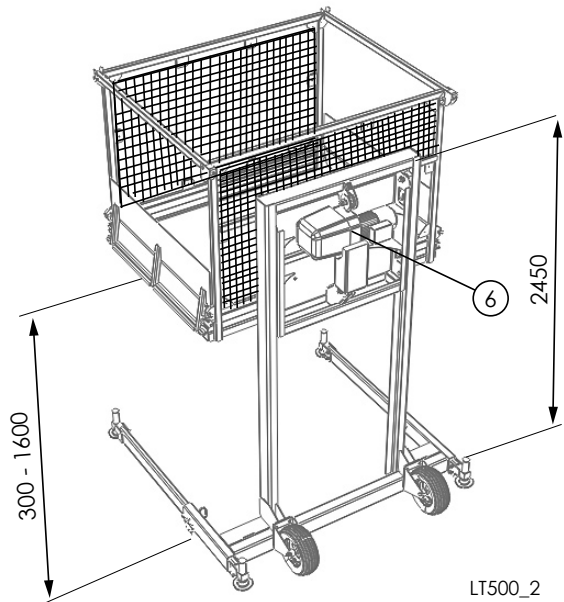
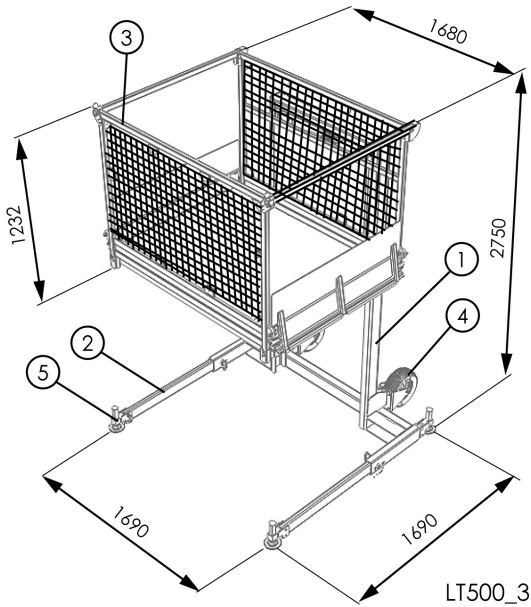

### PARTS LIST LT500

1	Frame	PG104992
2	Telescopic beam	PG104648
3	Platform complete	PG104995
4	Wheel complete	PG104639
5	Jack	07010100
6	Electrical chain winch, <b>optional</b> CPM 6-6 YALE	50723096
7	Loading bridge	PG105091
8	Railing	PG105020
9	Roller complete	PG104994
10	Grid	PG105086
11	Grid	PG104553

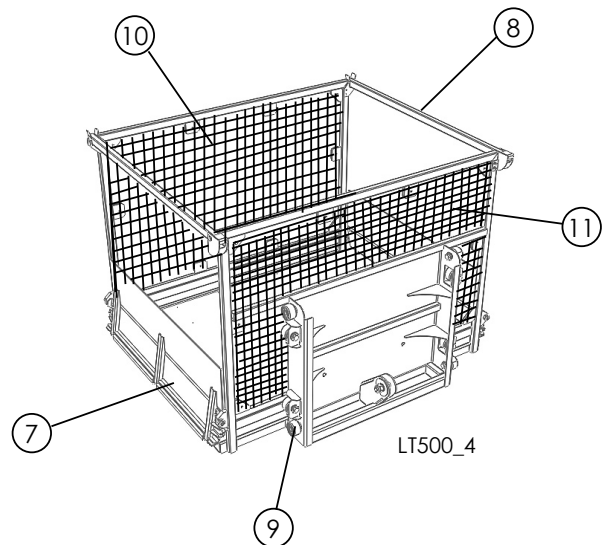

## 4. Instruction and warning decals

<b>SCANCLIMBER®</b>	<b>CE</b>
<b>LIFTING TABLE</b>	
TYPE <b>LT500</b> SERIAL N°	<input type="text"/>
YEAR OF MANUFACTURE:	<input type="text" value="2004"/>
MAXIMUM LOAD (kg):	<input type="text" value="500"/>
COUNTRY OF MANUFACTURE: POLAND	
<b>OY SCANINTER NOKIA LTD FINLAND</b>	

T01\_LT500

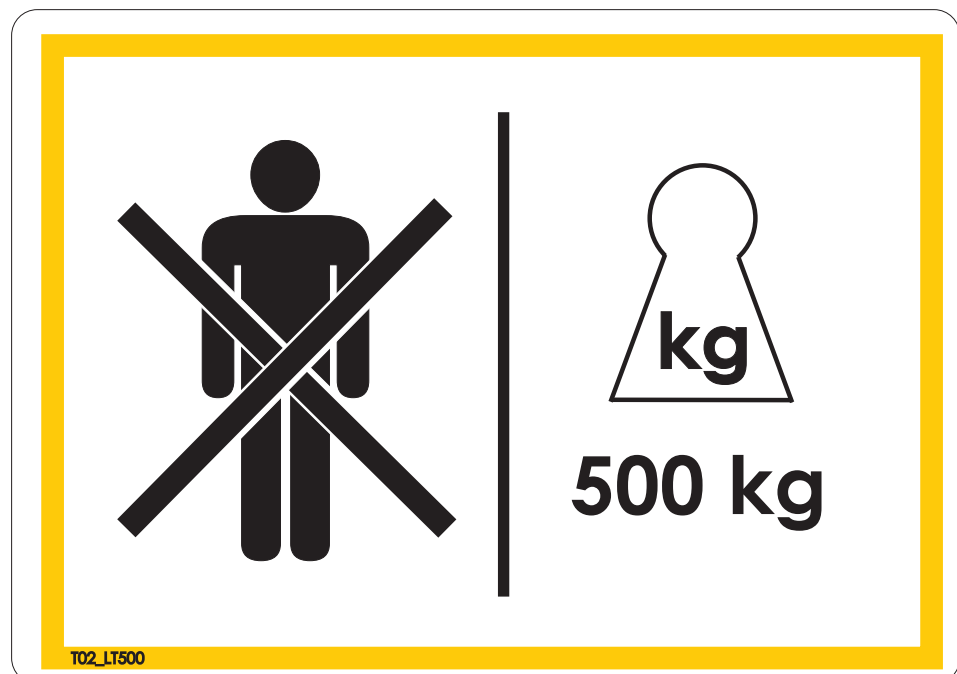



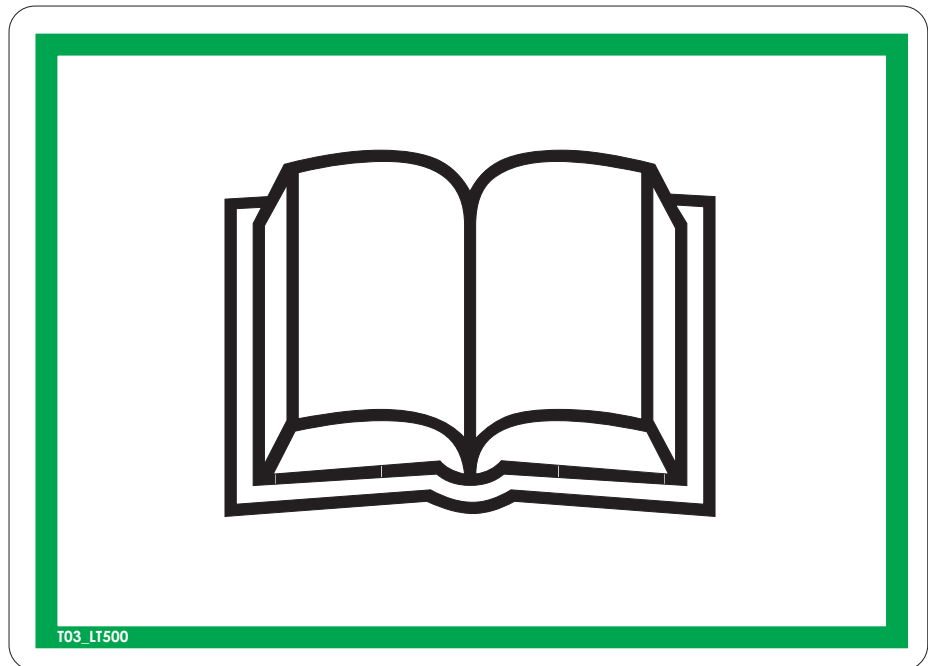

## 5. Electric drawing

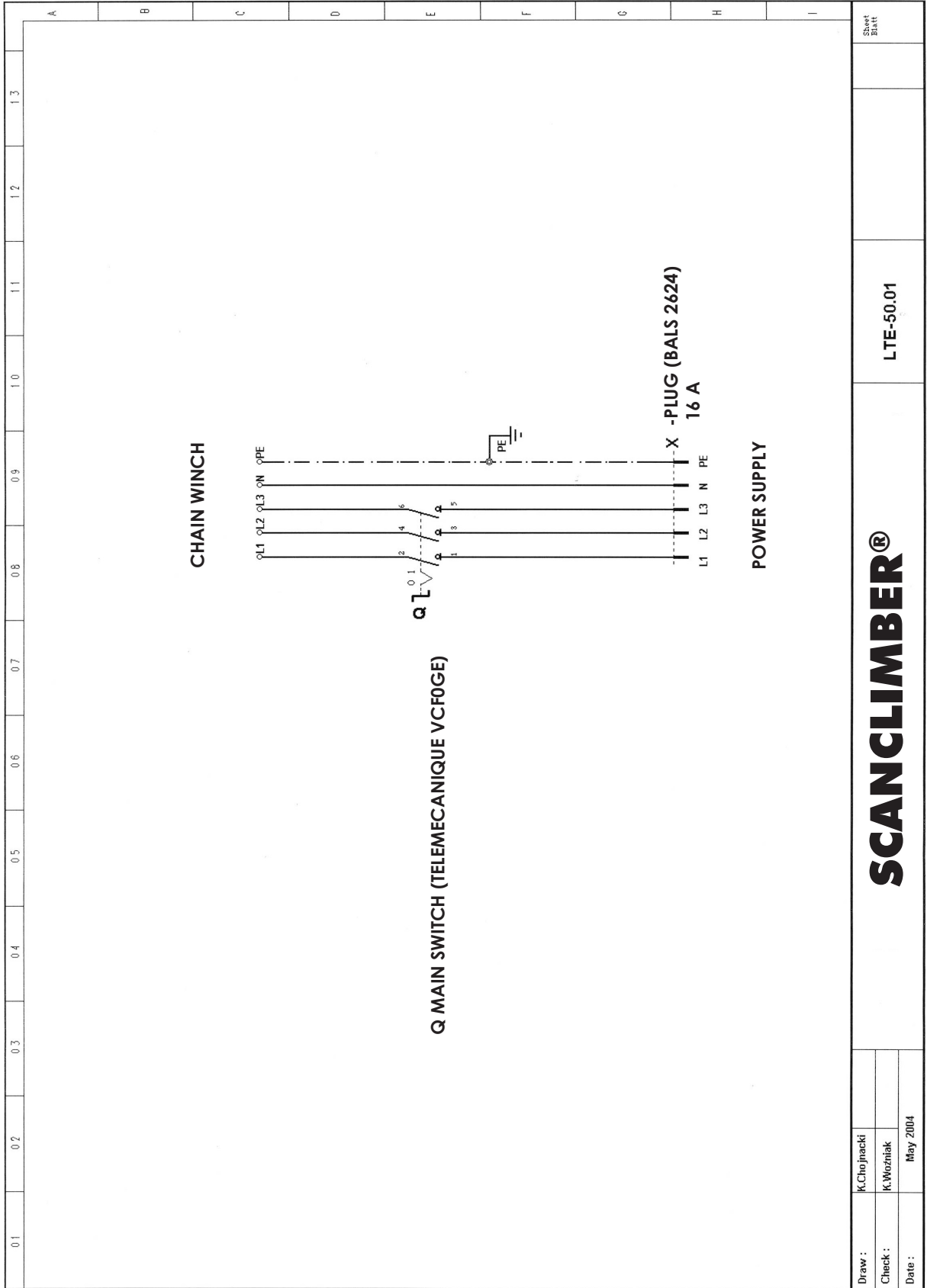

Draw :	K.Chojnacki
Check :	K.Wozniak
Date :	May 2004

**SCANCLIMBER®**

LTE-50.01

Sheet  
Blatt