



RELIANCE L-810(L) OBSL-L Steady Burning LED Obstruction Light  
Single with Optional IR Content

## Spare Parts

SP\_3086, Rev. A, 2020/04/28

  
**ADB  
SAFEGATE**



## A.0 Disclaimer / Standard Warranty

### CE certification

The equipment listed as CE certified means that the product complies with the essential requirements concerning safety and hygiene. The European directives that have been taken into consideration in the design are available on written request to ADB SAFEGATE.

### ETL certification

The equipment listed as ETL certified means that the product complies with the essential requirements concerning safety and FAA Airfield regulations. The FAA directives that have been taken into consideration in the design are available on written request to ADB SAFEGATE.

### All Products Guarantee

ADB SAFEGATE will correct by repair or replacement per the applicable guarantee above, at its option, equipment or parts which fail because of mechanical, electrical or physical defects, provided that the goods have been properly handled and stored prior to installation, properly installed and properly operated after installation, and provided further that Buyer gives ADB SAFEGATE written notice of such defects after delivery of the goods to Buyer. Refer to the Safety section for more information on Material Handling Precautions and Storage precautions that must be followed.

ADB SAFEGATE reserves the right to examine goods upon which a claim is made. Said goods must be presented in the same condition as when the defect therein was discovered. ADB SAFEGATE further reserves the right to require the return of such goods to establish any claim.

ADB SAFEGATE's obligation under this guarantee is limited to making repair or replacement within a reasonable time after receipt of such written notice and does not include any other costs such as the cost of removal of defective part, installation of repaired product, labor or consequential damages of any kind, the exclusive remedy being to require such new parts to be furnished.

ADB SAFEGATE's liability under no circumstances will exceed the contract price of goods claimed to be defective. Any returns under this guarantee are to be on a transportation charges prepaid basis. For products not manufactured by, but sold by ADB SAFEGATE, warranty is limited to that extended by the original manufacturer. This is ADB SAFEGATE's sole guarantee and warranty with respect to the goods; there are no express warranties or warranties of fitness for any particular purpose or any implied warranties of fitness for any particular purpose or any implied warranties other than those made expressly herein. All such warranties being expressly disclaimed.

### Standard Products Guarantee

Products of ADB SAFEGATE manufacture are guaranteed against mechanical, electrical, and physical defects (excluding lamps) which may occur during proper and normal use for a period of two years from the date of ex-works delivery, and are guaranteed to be merchantable and fit for the ordinary purposes for which such products are made.



#### Note

See your sales order contract for a complete warranty description.

### FAA Certified product installed in the United States or in US Military installations guarantee

ADB SAFEGATE L858 Airfield Guidance Signs are warranted against mechanical and physical defects in design or manufacture for a period of 2 years from date of installation, per FAA AC 150/5345-44 (applicable edition).

ADB SAFEGATE L858(L) Airfield Guidance Signs are warranted against electrical defects in design or manufacture of the LED or LED specific circuitry for a period of 4 years from date of installation, per FAA EB67 (applicable edition).

ADB SAFEGATE LED light fixtures (with the exception of obstruction lighting) are warranted against electrical defects in design or manufacture of the LED or LED specific circuitry for a period of 4 years from date of installation, per FAA EB67 (applicable edition).



## Note

See your sales order contract for a complete warranty description.

---

## Liability

---



### WARNING

Use of the equipment in ways other than described in the catalog leaflet and the manual may result in personal injury, death, or property and equipment damage. Use this equipment only as described in the manual.

---

ADB SAFEGATE cannot be held responsible for injuries or damages resulting from non-standard, unintended uses of its equipment. The equipment is designed and intended only for the purpose described in the manual. Uses not described in the manual are considered unintended uses and may result in serious personal injury, death or property damage.

Unintended uses, includes the following actions:

- Making changes to equipment that have not been recommended or described in this manual or using parts that are not genuine ADB SAFEGATE replacement parts or accessories.
- Failing to make sure that auxiliary equipment complies with approval agency requirements, local codes, and all applicable safety standards if not in contradiction with the general rules.
- Using materials or auxiliary equipment that are inappropriate or incompatible with your ADB SAFEGATE equipment.
- Allowing unskilled personnel to perform any task on or with the equipment.

## © ADB SAFEGATE BV

This manual or parts thereof may not be reproduced, stored in a retrieval system, or transmitted, in any form or by any means, electronic, mechanical, photocopying, recording, nor otherwise, without ADB SAFEGATE BV's prior written consent.

This manual could contain technical inaccuracies or typographical errors. ADB SAFEGATE BV reserves the right to revise this manual from time to time in the contents thereof without obligation of ADB SAFEGATE BV to notify any person of such revision or change. Details and values given in this manual are average values and have been compiled with care. They are not binding, however, and ADB SAFEGATE BV disclaims any liability for damages or detriments suffered as a result of reliance on the information given herein or the use of products, processes or equipment to which this manual refers. No warranty is made that the use of the information or of the products, processes or equipment to which this manual refers will not infringe any third party's patents or rights. The information given does not release the buyer from making their own experiments and tests.

# TABLE OF CONTENTS

<b>1.0 Reliance Steady Burning LED Obstruction Light, L-810(L) OBSL-L .....</b>	<b>1</b>
1.1 Reliance OBSL-L Introduction .....	1
1.1.1 Obstruction Light .....	2
<b>2.0 Reliance Steady Burning LED Obstruction Light, OBSL Parts .....</b>	<b>3</b>
2.1 OBSL-L Spare Components .....	3
<b>A.0 SUPPORT .....</b>	<b>7</b>
A.1 ADB SAFEGATE Website .....	7
A.2 Recycling .....	8
A.2.1 Local Authority Recycling .....	8
A.2.2 ADB SAFEGATE Recycling .....	8



---

# 1.0 Reliance Steady Burning LED Obstruction Light, L-810(L) OBSL-L

Reliance Steady Burning LED Obstruction Light with optional IR content.

## 1.1 Reliance OBSL-L Introduction

This section describes the L-810(L) Single ( [Figure 1](#) ) Reliance IL OBSL-L steady burning obstruction light.



### 1.1.1 Obstruction Light

#### Compliance with Standards

---

FAA:	L-810(L) AC 150/5345-43 (Current Edition) and the FAA Engineering Briefs No. 67 and No. 98. ETL Certified.
ICAO:	Annex 14, Vol. 1, para. 6.3, Type A & B
T/C:	Canadian Standard 621, Tables 13-3 and 13-4; Canadian Standard 621 Figures 13-2

---

#### Uses

**FAA L-810(L), ICAO, T/C** Steady-burning red light fixture marking all fixed obstructions to eliminate air navigational hazards.

#### Electrical Supply

---

Single OBSL-L with heater	VA Load
120 VAC:	24.21 VA
120 VAC with IR:	27.2 VA
Single OBSL-L without heater	VA Load
95-277 VAC	9.21 VA
95-277 VAC with IR:	12.2 VA
12 VDC:	6.47 VA
12 VDC with IR:	9.51 VA
24 VDC:	6.44 VA
24 VDC with IR:	9.49 VA
48 VDC:	6.63 VA
48 VDC with IR:	9.59 VA

---



## 2.0 Reliance Steady Burning LED Obstruction Light, OBSL Parts

To order parts, call ADB Safegate Customer Service Center or your local representative. Use the accompanying illustrations, part number callouts and descriptions to identify and order parts correctly.

### Ordering Code

OBSL - X X X X X X X X

#### Specification

- 1 = Obstruction Light Red, FAA
- 2 = Obstruction Light Red, ICAO, Type A & B, Canada<sup>3</sup>

#### Mounting

- 1 = Single, bottom mount 1"-11.5 NPT

#### Power

- 1 = 95-277 VAC, ±10%, 50/60 Hz<sup>1</sup>
- 2 = 24-48 VDC
- 3 = 12 VDC

#### Control

- 0 = No control

#### Alarm

- 0 = No alarm contact

#### Photocell

- 0 = No photocell

#### IR

- 0 = Without IR
- 1 = IR and visible light output

#### Arctic Option

- 0 = Without arctic option
- 1 = With arctic option<sup>2</sup>

#### Flashing

- 0 = No flash
- 1 = Flashing (30 flashes per minute)<sup>3</sup>

#### Notes

- <sup>1</sup> Fixture (without heater) is designed to operate from 95 VAC (min.) to 277 VAC (max.), 50/60 Hz.
- <sup>2</sup> When powered by a parallel circuit, heater is designed for use at only 120 VAC, ±10%, 50/60 Hz.
- <sup>3</sup> Not ETL Certified.

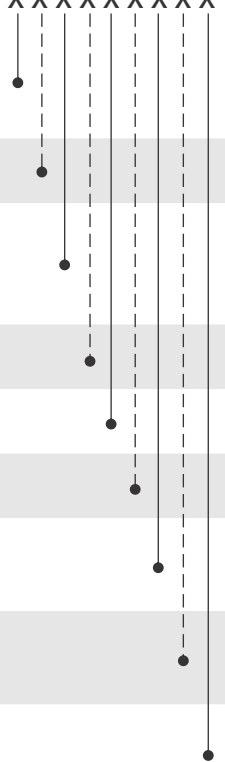

### 2.1 OBSL-L Spare Components

Description	Part No.	Note
Glassware, Clear, ICAO	63A1117-C	Figure 2
Glassware, Red, FAA	63A1117-R	Figure 2
Lens Attaching Door	62A2265	Figure 2
OBSL-L Light Assembly	44A7668-XXXXX	Figure 2
Seal, Side Emitting Lens	63A1279	Figure 2
Cordset	44A7672/1	Figure 1
O-Ring Seal	61A0551	Figure 2
Power Supply Assembly AC, W-IR	44A7667/AC00	Figure 1
Power Supply Assembly 12VDC, W-IR	44A7667/D100	Figure 1

Description	Part No.	Note
Power Supply Assembly 24-48 VDC, W-IR	44A7667/D200	Figure 1
Harness Assy, Power Supply To LED Driver	44A7567	Figure 1
LED Light Engine	44A7614/XXXX	See: Table 1.

Figure 1: OBSL Assembly Parts

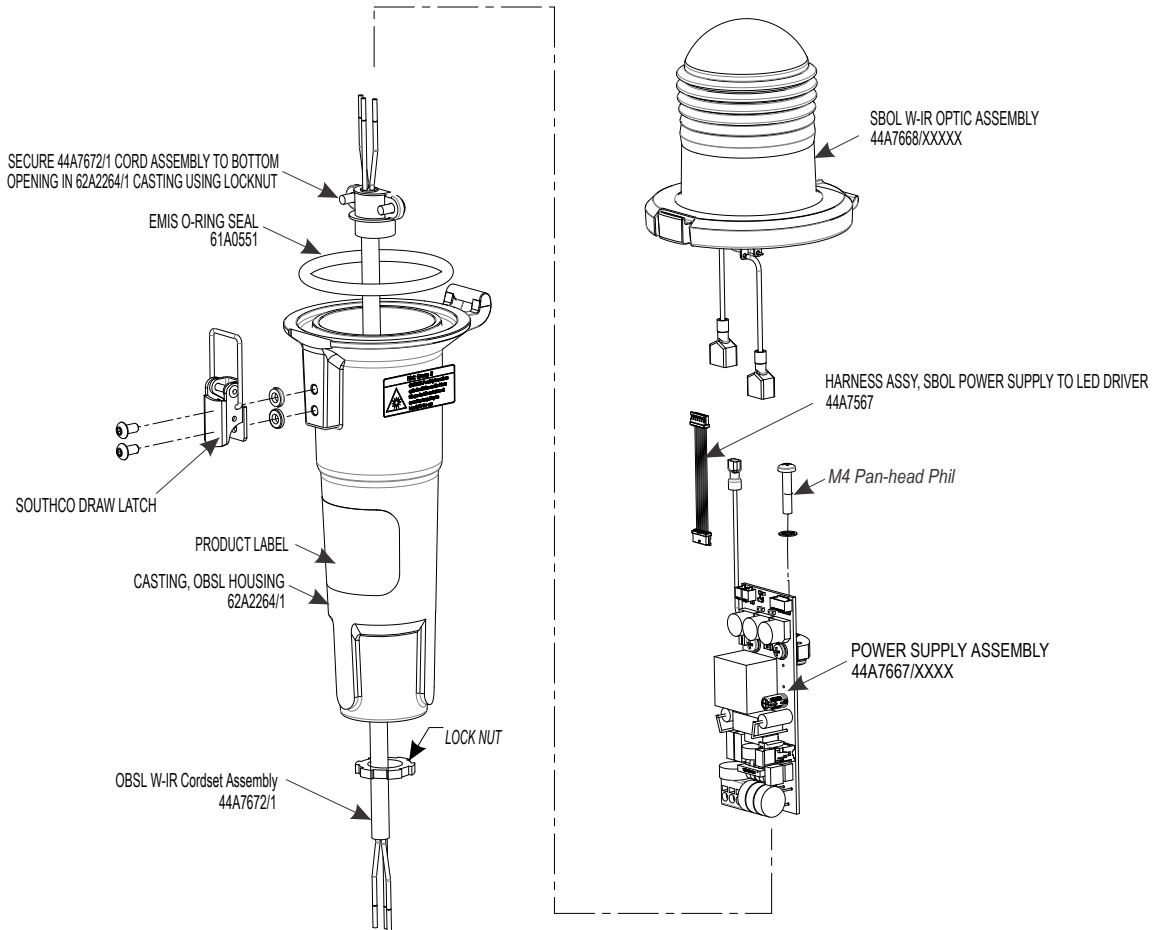

**Figure 2: Glassware Assembly Parts**

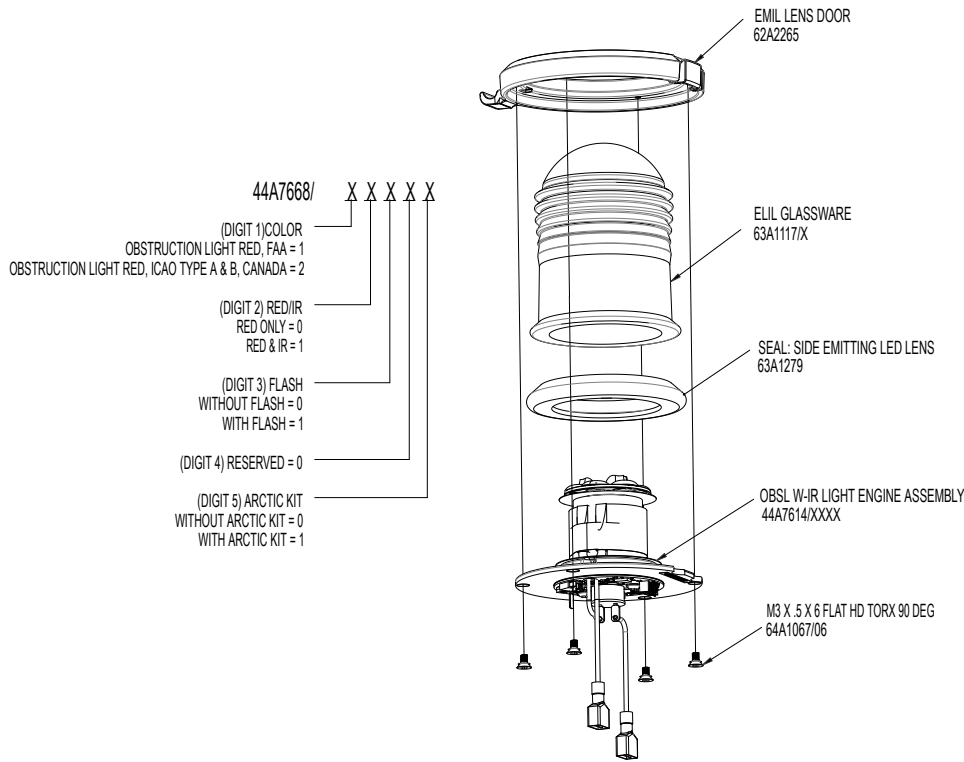

1. SECURE M3 FASTENERS WITH MEDIUM STRENGTH LOCTITE 242.

**Table 1: LED Light Engine Order Code**

44A7614/	X1	X2	X3	X4
<b>IR Content</b>				
	0 - Red Visible Light Only			
	1 - Red and IR			
<b>Flash Option</b>				
	0 - Without Flash			
	1 - With Flash			
			Not Used (0)	
<b>Arctic Kit (Heater, 120 Vac Only)</b>				
			0 - Without Arctic Kit	
			1 - With Arctic Kit (120 Vac Only)	



## Appendix A: SUPPORT

Our experienced engineers are available for support and service at all times, 24 hour/7 days a week. They are part of a dynamic organization making sure the entire ADB SAFEGATE is committed to minimal disturbance for airport operations.

### ADB SAFEGATE Support

#### Live Technical Support - Americas

If at any time you have a question or concern about your product, just contact ADB SAFEGATE's technical service department. Trained in all areas of system issues, troubleshooting, quality control and technical assistance, our highly experienced Technical support specialists are available 24 hours a day, seven days a week to provide assistance over the phone.

ADB SAFEGATE **Americas Technical Service & Support (US & Canada): +1-800-545-4157**

**ADB SAFEGATE Americas Technical Service & Support (International): +1-614-861-1304**

During regular business hours, you can also Chat with a Service Technician. We look forward to working with you!

#### Before You Call

When you have an airfield lighting or system control system problem it is our goal to support airfield maintenance staff as quickly as possible. To support this effort we ask that you have the following information ready before calling.

- The *airport code*
- If not with an airport, then company name (prefer customer id number)
- Contact phone number and email address
- Product with part number preferable or product number
- Have you reviewed the product's manual and troubleshooting guide
- Do you have a *True RMS* meter available (and any other necessary tools)
- Be located with the product ready to troubleshoot

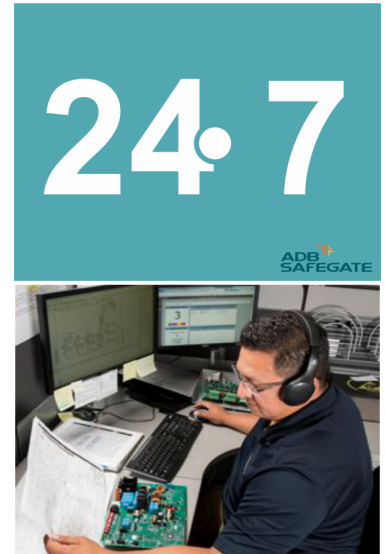

#### Note

For more information, see [www.adbsafegate.com](http://www.adbsafegate.com), or contact ADB SAFEGATE Support via email at [support@adbsafegate.com](mailto:support@adbsafegate.com) or

Brussels: +32 2 722 17 11

Rest of Europe: +46 (0) 40 699 17 40

Americas: +1 614 861 1304. Press 3 for technical service or press 4 for sales support.

China: +86 (10) 8476 0106

### A.1 ADB SAFEGATE Website

The ADB SAFEGATE website, [www.adbsafegate.com](http://www.adbsafegate.com), offers information regarding our airport solutions, products, company, news, links, downloads, references, contacts and more.

## A.2 Recycling

### A.2.1 Local Authority Recycling

The disposal of ADB SAFEGATE products is to be made at an applicable collection point for the recycling of electrical and electronic equipment. The correct disposal of equipment prevents any potential negative consequences for the environment and human health, which could otherwise be caused by inappropriate waste handling. The recycling of materials helps to conserve natural resources. For more detailed information about recycling of products, contact your local authority city office.

### A.2.2 ADB SAFEGATE Recycling

ADB SAFEGATE is fully committed to environmentally-conscious manufacturing with strict monitoring of our own processes as well as supplier components and sub-contractor operations. ADB SAFEGATE offers a recycling program for our products to all customers worldwide, whether or not the products were sold within the EU.

ADB SAFEGATE products and/or specific electrical and electronic component parts which are fully removed/separated from any customer equipment and returned will be accepted for our recycling program.

All items returned must be clearly labelled as follows:

- For *ROHS/WEEE* Recycling
- Sender contact information (Name, Business Address, Phone number).
- Main Unit Serial Number.

ADB SAFEGATE will continue to monitor and update according for any future requirements for *EU directives* as and when *EU member states* implement new *regulations* and or *amendments*. It is our aim to maintain our *compliance plan* and assist our customers.

## Company Addresses

ADB SAFEGATE	ADB SAFEGATE, Belgium: Leuvensesteenweg 585, B-1930 Zaventem Belgium
Contact: Tel.: +32 2 722 17 11, Fax: +32 2 722 17 64	Email: <a href="mailto:marketing@adbsafegate.com">marketing@adbsafegate.com</a> Internet: <a href="http://www.adbsafegate.com">www.adbsafegate.com</a>
Americas LLC	ADB SAFEGATE, Americas: 977 Gahanna Parkway, Columbus, OH 43230 USA
Contact: Tel.: +1 (614) 861 1304, Fax: +1 (614) 864 2069	Email: <a href="mailto:sales.us@adbsafegate.com">sales.us@adbsafegate.com</a> Internet: <a href="http://www.adbsafegate.com">www.adbsafegate.com</a>
ADB SAFEGATE Sweden AB	ADB SAFEGATE, Sweden: Djurhagegatan 19 SE-213 76 Malmö Sweden
Contact: Tel.: +46 (0)40 699 17 00, Fax: +46 (0)40 699 17 30	Email: <a href="mailto:marketing@adbsafegate.com">marketing@adbsafegate.com</a> Internet: <a href="http://www.adbsafegate.com">www.adbsafegate.com</a>
ADB SAFEGATE Airfield Technologies Ltd. China	ADB SAFEGATE, China: Unit 603, D Block, CAMIC International Convention Center, No 3, Hua Jia Di East road, ChaoYang district, Beijing 100102 P.R. China
Contact: Tel.: +86 (10) 8476 0106, Fax: +86 (10) 8476 0090	Email: <a href="mailto:china@safegate.com">china@safegate.com</a> Internet: <a href="http://www.adbsafegate.com">www.adbsafegate.com</a>
ADB SAFEGATE Germany GmbH	ADB SAFEGATE Germany GmbH, Mannheim: Konrad-Zuse-Ring 6, D-68163 Mannheim Germany
Contact: Tel.: +49 (621) 87 55 76-0, Fax: +49 (621) 87 55 76-55	Email: <a href="mailto:marketing@adbsafegate.com">marketing@adbsafegate.com</a> Internet: <a href="http://www.adbsafegate.com">www.adbsafegate.com</a>



## Powering Your Airport Performance from Approach to Departure

[adbsafegate.com](https://adbsafegate.com)

Copyright © ADB SAFEGATE, all rights reserved

