



CCT (Thyristor Controlled) L-828/L-829 Constant Current Regulator

Air-Cooled, 4-30 kW/6.6 A

Instruction Manual

96A0296, Rev. T, 11/13/17

A.0 Disclaimer / Standard Warranty

A.1 CE certification

The equipment listed as CE certified means that the product complies with the essential requirements concerning safety and hygiene. The directives that have been taken into consideration in the design are available on written request to ADB SAFEGATE.

A.2 ETL certification

The equipment listed as ETL certified means that the product complies with the essential requirements concerning safety and FAA Airfield regulations. The directives that have been taken into consideration in the design are available on written request to ADB SAFEGATE.

A.3 LED Product Guarantee

Where applicable, per FAA EB67 (applicable edition), ADB SAFEGATE L858(L) Airfield Guidance Signs are warranted against electrical defects in design or manufacture of the LED or LED specific circuitry for a period of 4 years. ADB SAFEGATE LED light fixtures (with the exception of obstruction lighting) are warranted against mechanical and physical defects in design or manufacture for a period of 12 months from date of installation; and are warranted against electrical defects in design or manufacture of the LED or LED specific circuitry for a period of 4 years per FAA EB67 (applicable edition).

NOTE: See your sales order contract for a complete warranty description. In some specific cases, deviations are (to be) accepted in the contract, which will supersede the standard warranty.

A.4 Standard Product Guarantee

Products of ADB SAFEGATE manufacture are guaranteed against mechanical, electrical, and physical defects (excluding lamps) which may occur during proper and normal use for a period of one year from the date of installation or 2 years from date of shipment and are guaranteed to be merchantable and fit for the ordinary purposes for which such products are made. ADB SAFEGATE L858 Airfield Guidance Signs are warranted against mechanical and physical defects in design or manufacture for a period of 2 years from date of installation per FAA AC 150/5345-44 (applicable edition).

NOTE: See your sales order contract for a complete warranty description.

A.5 All Products

LED Products of ADB SAFEGATE, manufactured and sold by ADB SAFEGATE or its licensed representatives, meets the corresponding requirements of FAA, ICAO and IEC.

ADB SAFEGATE will correct by repair or replacement per the applicable guarantee above, at its option, equipment or parts which fail because of mechanical, electrical or physical defects, provided that the goods have been properly handled and stored prior to installation, properly installed and properly operated after installation, and provided further that Buyer gives ADB SAFEGATE written notice of such defects after delivery of the goods to Buyer. Refer to the Safety section for more information on Material Handling Precautions and Storage precautions that must be followed.

ADB SAFEGATE reserves the right to examine goods upon which a claim is made. Said goods must be presented in the same condition as when the defect therein was discovered. ADB SAFEGATE further reserves the right to require the return of such goods to establish any claim.

ADB SAFEGATE's obligation under this guarantee is limited to making repair or replacement within a reasonable time after receipt of such written notice and does not include any other costs such as the cost of removal of defective part, installation of repaired product, labor or consequential damages of any kind, the exclusive remedy being to require such new parts to be furnished.

ADB SAFEGATE's liability under no circumstances will exceed the contract price of goods claimed to be defective. Any returns under this guarantee are to be on a transportation charges prepaid basis. For products not manufactured by, but sold by ADB SAFEGATE, warranty is limited to that extended by the original manufacturer.

This is ADB SAFEGATE's sole guarantee and warranty with respect to the goods; there are no express warranties or warranties of fitness for any particular purpose or any implied warranties of fitness for any particular purpose or any implied warranties other than those made expressly herein. All such warranties being expressly disclaimed.

A.6 Liability



WARNING

Use of the equipment in ways other than described in the catalogue leaflet and the manual may result in personal injury, death, or property and equipment damage. Use this equipment only as described in the manual.

ADB SAFEGATE cannot be held responsible for injuries or damages resulting from non-standard, unintended uses of its equipment. The equipment is designed and intended only for the purpose described in the manual. Uses not described in the manual are considered unintended uses and may result in serious personal injury, death or property damage.

Unintended uses includes the following actions:

- Making changes to equipment that have not been recommended or described in this manual or using parts that are not genuine ADB SAFEGATE replacement parts or accessories.
- Failing to make sure that auxiliary equipment complies with approval agency requirements, local codes, and all applicable safety standards if not in contradiction with the general rules.
- Using materials or auxiliary equipment that are inappropriate or incompatible with your ADB SAFEGATE equipment.
- Allowing unskilled personnel to perform any task on or with the equipment.

A.7 © ADB SAFEGATE BVBA

This manual or parts thereof may not be reproduced, stored in a retrieval system, or transmitted, in any form or by any means, electronic, mechanical, photocopying, recording, nor otherwise, without ADB SAFEGATE BVBA's prior written consent.

This manual could contain technical inaccuracies or typographical errors. ADB SAFEGATE BVBA reserves the right to revise this manual from time to time in the contents thereof without obligation of ADB SAFEGATE BVBA to notify any person of such revision or change. Details and values given in this manual are average values and have been compiled with care. They are not binding, however, and ADB SAFEGATE BVBA disclaims any liability for damages or detriments suffered as a result of reliance on the information given herein or the use of products, processes or equipment to which this manual refers. No warranty is made that the use of the information or of the products, processes or equipment to which this manual refers will not infringe any third party's patents or rights. The information given does not release the buyer from making their own experiments and tests.

TABLE OF CONTENTS

A.0	Disclaimer / Standard Warranty.....	ii
1.0	Safety.....	1
1.1	HAZARD Icons used in the manual	1
1.2	To use this equipment safely	2
2.0	Introduction.....	5
2.1	About this manual	5
2.1.1	How to work with the manual	5
2.1.2	Record of changes	5
2.2	CCT Introduction	6
2.3	Compliance with Standards	6
2.4	Features	6
2.5	Electrical Supply	7
2.5.1	Remote Control	7
2.5.2	Total Harmonic Distortion* (THD)	7
2.5.3	Theory of Operation Introduction	7
2.6	ACE Unit	7
2.7	Environmental Operating Conditions	8
2.7.1	Monitoring Option	8
2.7.2	Application Notes	8
2.8	Theory of Operation	9
2.8.1	Power Circuit	9
2.8.2	Output Measurement	9
2.8.3	CCT Control PCB	9
2.8.3.1	URC PCB Inputs/Outputs	9
2.8.4	Output Current Monitor Circuitry	10
2.8.5	Local Control Position Detection	10
2.8.6	Contactors Drive	10
2.8.7	Remote Control Position Detection	10
2.8.8	Fault Protection	10
2.9	L-828 CCR	11
2.10	L-829 CCR	12
2.11	CCT Control Board	13
2.11.1	L-829 Advanced Control Equipment (ACE)	14
2.12	L-828/L-829 CCR Monitoring Options	15
2.12.1	Optional Insulation Resistance Monitoring System	15
2.12.2	Optional Scanning Monitor Interface	15
2.12.3	Optional Scanning Monitor Ready	15
2.13	Optional Series Cutout Type SCO	15
2.14	L-828 CCRs (4-70 kW 6.6 A/ 20 A): Required Equipment	16
2.15	Input Wire Size	16
2.16	Input Power Breaker Sizing	17
2.17	Specifications	18
2.17.1	Efficiency	18
2.17.2	Reactive Loading	18
2.17.3	Resistive Loading	18
2.17.4	Regulation	18
2.17.5	Environmental Operating Conditions	19
2.17.6	Protection Devices	19
2.17.6.1	Open-Circuit Protection.....	19
2.17.6.2	Overcurrent Protection	19
2.17.7	Input Voltage	19
2.17.7.1	Built-In True-rms-Reading Ammeter, L-828 only	19
2.17.7.2	Rating and Input Voltage	19

TOC

2.17.8	Temperature Rise	20
2.17.9	Dimensions	20
2.17.10	Weight	20
3.0	CCT Installation	21
3.1	Unpacking	21
3.2	Installation	21
3.2.1	Wiring Connections and Startup	22
3.3	Stacking CCR's (Optional)	23
3.4	Frames	26
4.0	CCT Operation	27
4.1	Introduction	27
4.2	CCR Control Procedures	27
4.2.1	Local Control	27
4.2.2	Remote Control	28
4.3	CCR Shutdown Procedure	28
4.4	CCR Adjustment Procedures	28
4.4.1	Output Current Adjustment	29
4.4.1.1	Regulator Control Board (44D1475)	29
4.4.1.2	Adjusting Overcurrent Control Board (44D1475)	31
4.4.2	Adjusting Output Current (44A6546)	32
4.4.2.1	Adjusting Overcurrent Control Board (44A6546)	33
4.4.3	Reducing CCR Power Consumption	34
4.4.3.1	Adjusting Over Current	34
4.5	SCO Cutout Working Positions	35
4.6	Application Notes	37
4.7	Digital Power Meter Calibration	38
4.7.1	Function Buttons	38
4.7.1.1	Displays	38
4.7.2	Calibration	39
5.0	CCT Maintenance.....	41
5.1	Introduction to Maintenance	41
5.2	Maintenance Schedule	41
5.2.1	Short-Circuit Test	42
5.2.2	Open-Circuit Test	42
5.3	Troubleshooting	43
5.4	Introduction	43
5.5	Preliminary Troubleshooting	43
5.6	Troubleshooting	44
5.6.1	L-828/L-829 Input Power Fuses F1 and F2.	44
5.6.2	L-828 General Troubleshooting	50
5.7	Additional L-829 General Troubleshooting Procedures	51
5.8	Component Replacement Procedures	52
5.8.1	Removing and Replacing CCT Regulator Control PCB	52
5.8.2	Removing and Replacing Dual SCR Module Assembly	54
5.8.3	Removing and Replacing Contactor	55
5.8.4	Removing and Replacing Input Lightning Arrestors (front of Component Mounting Plate)	55
5.8.5	Removing and Replacing Output Lightning Arrestors (front of Component Mounting Plate)	56
6.0	Schematics.....	59
7.0	CCT Parts.....	65
7.1	L-828/L-829 CCR (4-30 kW) Parts Ordering Codes	65
7.1.1	L-828/L-829 CCR General Assembly (4-30 kW/208-480 Vac) Parts List	66
7.1.2	Assembly Parts	67
7.1.2.1	15-30 KW CCT Regulator Parts	67
7.1.2.2	4-10 KW CCT Regulator Parts.....	76





1.0 Safety

This section contains general safety instructions for installing and using ADB Safegate equipment. Some safety instructions may not apply to the equipment in this manual. Task- and equipment-specific warnings are included in other sections of this manual where appropriate.

1.1 HAZARD Icons used in the manual

For all HAZARD symbols in use, see the Safety section. All symbols must comply with ISO and ANSI standards.

Carefully read and observe all safety instructions in this manual, which alert you to safety hazards and conditions that may result in personal injury, death or property and equipment damage and are accompanied by the symbol shown below.

	WARNING <ul style="list-style-type: none">Failure to observe a warning may result in personal injury, death or equipment damage.
	DANGER - RISK OF ELECTRICAL SHOCK OR ARC FLASH <ul style="list-style-type: none">Disconnect equipment from line voltage. Failure to observe this warning may result in personal injury, death, or equipment damage. ARC Flash may cause blindness, severe burns or death.
	WARNING - WEAR PERSONAL PROTECTIVE EQUIPMENT <ul style="list-style-type: none">Failure to observe may result in serious injury.
	WARNING - DO NOT TOUCH <ul style="list-style-type: none">Failure to observe this warning may result in personal injury, death, or equipment damage.
	CAUTION <ul style="list-style-type: none">Failure to observe a caution may result in equipment damage.

1.1.1 Qualified Personnel



IMPORTANT INFORMATION

The term **qualified personnel** is defined here as individuals who thoroughly understand the equipment and its safe operation, maintenance and repair. Qualified personnel are physically capable of performing the required tasks, familiar with all relevant safety rules and regulations and have been trained to safely install, operate, maintain and repair the equipment. It is the responsibility of the company operating this equipment to ensure that its personnel meet these requirements.

ALWAYS USE REQUIRED PERSONAL PROTECTIVE EQUIPMENT (PPE) AND FOLLOW SAFE ELECTRICAL WORK PRACTICE.

1.2 To use this equipment safely



WARNING

Read installation instructions in their entirety before starting installation.

- Become familiar with the general safety instructions in this section of the manual before installing, operating, maintaining or repairing this equipment.
- Read and carefully follow the instructions throughout this manual for performing specific tasks and working with specific equipment.
- Make this manual available to personnel installing, operating, maintaining or repairing this equipment.
- Follow all applicable safety procedures required by your company, industry standards and government or other regulatory agencies.
- Install all electrical connections to local code.
- Use only electrical wire of sufficient gauge and insulation to handle the rated current demand. All wiring must meet local codes.
- Route electrical wiring along a protected path. Make sure they will not be damaged by moving equipment.
- Protect components from damage, wear, and harsh environment conditions.
- Allow ample room for maintenance, panel accessibility, and cover removal.
- Protect equipment with safety devices as specified by applicable safety regulations.
- If safety devices must be removed for installation, install them immediately after the work is completed and check them for proper functioning prior to returning power to the circuit.

Failure to follow these warnings may result in serious injury or equipment damage.

1.2.1 Additional Reference Materials



IMPORTANT INFORMATION

- IEC - International Standards and Conformity Assessment for all electrical, electronic and related technologies
- IEC 60364 - Electrical Installations in Buildings
- FAA Advisory: AC 150/5340-26 (current edition) Maintenance of Airport Visual Aid Facilities
- ANSI/NFPA 79, Electrical Standards for Metalworking Machine Tools.
- National and local electrical codes and standards.

1.2.2 Intended Use



WARNING

IMPROPER USE

Using this equipment in ways other than described in this manual may result in personal injury, death or property and equipment damage. Use this equipment only as described in this manual.

Failure to follow these warnings may result in serious injury or equipment damage.

1.2.3 Fasteners



WARNING

FOREIGN OBJECT DAMAGE - FOD

- Only use fasteners of the same type as the one originally supplied with the equipment.
- Always tighten the fasteners to the recommended torque. Use a calibrated torque wrench and apply the recommended adhesive type.
- Obey the instructions of the adhesives necessary for the fasteners.

Failure to follow these warnings may cause the fasteners to loosen, damage the equipment, potentially to loosen the equipment. This can lead to a highly dangerous situation of FOD, with potential lethal consequences.

1.2.4 Operation



CAUTION

IMPROPER OPERATION

- Only qualified personnel, physically capable of operating the equipment and with no impairments in their judgment or reaction times, should operate this equipment.
- Read all system component manuals before operating this equipment. A thorough understanding of system components and their operation will help you operate the system safely and efficiently.
- Before starting this equipment, check all safety interlocks, fire-detection systems, and protective devices such as panels and covers. Make sure all devices are fully functional. Do not operate the system if these devices are not working properly. Do not deactivate or bypass automatic safety interlocks or locked-out electrical disconnects or pneumatic valves.
- Protect equipment with safety devices as specified by applicable safety regulations.
- If safety devices must be removed for installation, install them immediately after the work is completed and check them for proper functioning.
- Route electrical wiring along a protected path. Make sure they will not be damaged by moving equipment.
- Never operate equipment with a known malfunction.
- Do not attempt to operate or service electrical equipment if standing water is present.
- Use this equipment only in the environments for which it is rated. Do not operate this equipment in humid, flammable, or explosive environments unless it has been rated for safe operation in these environments.
- Never touch exposed electrical connections on equipment while the power is ON.

Failure to follow this instruction can result in equipment damage.

1.2.5 Storage



CAUTION

IMPROPER STORAGE

If equipment is to be stored prior to installation, it must be protected from the weather and kept free of condensation and dust.

Failure to follow this instruction can result in equipment damage

1.2.6 Material Handling Precautions



CAUTION

ELECTROSTATIC SENSITIVE DEVICES

This equipment may contain electrostatic sensitive devices.

- Protect from electrostatic discharge.
- Electronic modules and components should be touched only when this is unavoidable e.g. soldering, replacement.
- Before touching any component of the cabinet you should bring your body to the same potential as the cabinet by touching a conductive earthed part of the cabinet.
- Electronic modules or components must not be brought in contact with highly insulating materials such as plastic sheets, synthetic fiber clothing. They must be laid down on conductive surfaces.
- The tip of the soldering iron must be grounded.
- Electronic modules and components must be stored and transported in conductive packing.

Failure to follow this instruction can result in equipment damage



1.2.7 Action in the Event of a System or Component Malfunction



WARNING

UNSTABLE LOAD

- Use extreme care when moving heavy equipment.
- Verify that the moving equipment is rated to handle the weight.
- When removing equipment from a shipping pallet, carefully balance and secure it using a safety strap.



Failure to follow these instructions can result in death, serious injury, or equipment damage.

1.2.8 Maintenance



WARNING

ELECTRIC SHOCK HAZARD

- Do not operate a system that contains malfunctioning components. If a component malfunctions, turn the system OFF immediately.
- Disconnect and lock out electrical power.
- Allow only qualified personnel to make repairs. Repair or replace the malfunctioning component according to instructions provided in its manual.

Failure to follow these warnings will result in death or equipment damage.

1.2.9 Maintenance and Repair



DANGER

ARC FLASH AND ELECTRIC SHOCK HAZARD

Allow only qualified personnel to perform maintenance, troubleshooting, and repair tasks.

- Only persons who are properly trained and familiar with ADB Safegate equipment are permitted to service this equipment.
- An open airfield current circuit is capable of generating >5000 Vac and may appear OFF to a meter.
- Never unplug a device from a constant current circuit while it is operating. Arc flash may result.
- Disconnect and lock out electrical power.
- Always use safety devices when working on this equipment.
- Follow the recommended maintenance procedures in the product manuals.
- Do not service or adjust any equipment unless another person trained in first aid and CPR is present.
- Connect all disconnected equipment ground cables and wires after servicing equipment. Ground all conductive equipment.
- Use only approved ADB Safegate replacement parts. Using unapproved parts or making unapproved modifications to equipment may void agency approvals and create safety hazards.
- Check the interlock systems periodically to ensure their effectiveness.
- Do not attempt to service electrical equipment if standing water is present. Use caution when servicing electrical equipment in a high-humidity environment.
- Use tools with insulated handles when working with airfield electrical equipment.

Failure to follow these warnings will result in death or equipment damage.

2.0 Introduction

CCT (Thyristor Controlled) L-828/L-829 Constant Current Regulator
Air-Cooled (4-30 kW) users manual.

2.1 About this manual

The manual shows the information necessary to:

- Install the CCT
- Carry Out Maintenance
- Carry Out Troubleshooting on the CCT (Thyristor Controlled) L-828/L-829 Constant Current Regulator.

2.1.1 How to work with the manual

1. Familiarize yourself with the structure and content.
2. Carry out the actions completely and in the given sequence.

2.1.2 Record of changes

Page	Rev	Description	Checked	Approved	Date
All	D	Revised manual to include 20A CCRs	ED	WT	1/27/04
2-14	E	Revised dimensions in Table 2-12	WT	WT	8/29/05
4-10 thru 4-14 3-4	F	Added Digital Power Meter Calibration and added Input/output table	WT	WT	9/8/05
3-3 8-2, 8-3, 8-4	G	Added schematics and instructions on hooking up CCR to remote ACE. Revise Fig 8-1 and added Fig 8-2	WT	WT	9/27/05
3-4, 4-6	H	Removed references to CCT in Table 3-4 Added reducing power consumption table and instructions Table 4-7.	BB/WT	WT	6/23/06
2-4, 2-11, 2-12, 4-3 thru 4-6, 7- 3 thru 7-7, 8-2 thru 8-4	I	Replaced 44D1475 PCB with 44A6546. Updated Current Limits in Table 2-9. Updated input lightning protection as standard per 10F. Updated Current setting instructions. Updated spare parts & wiring diagram.	JJR	JJR	9/14/07
4-6	J	Updated Over Current Adjustment Instructions	JJR	JJR	9/17/07
2-2, 2-4, 2-8, 2-15, 4-2, 6-5, 7-2, 7-3, 8-1	K	Added reference to ACE2 manual 96A0357 and updated weights. Added notes and spares for input lightning protection.	JC	JC	1/7/08
	L	ADB			12/16/09
All	M	Added new cores, updated drawings and parts	JC	JR	8/17/10
All	N	New Format and updated entire manual	JC	JR	06/09/11
Front Cover	O	Front Cover Photo, Added 380V 50/60 Hz operation for Brazil.	JC	JR	02/15/12
All	P	updated minor inconsistencies	JC	JR	02/22/12
34	Q	Updated maintenance section	JC	JG	09/19/13
5, 63	R	Updated intro and Schematic sections	RW	JC	02/28/14
	S	Updated format. Updated Parts	RW		
all	T	added ACE 3, ALSC and re-branded - remove 20A	RW	RL	11/15/17

2.2 CCT Introduction



WARNING

Read the instructions in their entirety before starting installation.

This section describes the ADB Safegate Thyristor Controlled, L-828/L-829, constant current regulators (CCRs). These CCRs are manufactured according FAA specification AC 150/5345-10 (latest edition).

2.3 Compliance with Standards

FAA

L-828/L-829 AC 150/5345-10 (Current Edition) ETL Certified

ICAO

Aerodrome Design Manual Part 5, para. 3.2.1.4 to 3.2.1.6

Military

UFC 3-535-01; NAVAIR 51-50AAA-2

Uses

Supplies three or five precision output levels to power series lighting circuits on airport runways and taxiways.

2.4 Features

- Solid-state operation with no relays eliminates mechanical failures.
- Optional integrated ACE™ unit provides state-of-the-art remote control and L-829 monitoring capability. Unique “cycle” mode allows output True-RMS current and voltage, VA, watts, lamps-out, and series circuit insulation resistance value to be alternately displayed. A visual indication is also provided for all other FAA-monitored parameters, including open circuit, overcurrent, loss of input power, loss of input voltage, low VA (drop in load VA of 10%), Remote/Local status, and incorrect output current.
- No input turn on in-rush current surge.
- To minimize the floor space required in a vault, ADB 4-30kW regulators can be stacked using a stacking kit. See Kits section for details.
- Available in class 1 and styles 1 and 2:
 - Class 1 = 6.6A maximum output current
 - Style 1 = 3 Brightness Steps
 - Style 2 = 5 Brightness Steps
- Power taps on output winding of main transformer provide efficient (high primary power factor) operation at all load levels:
 - 10% taps from 10% to 100% on all CCR sizes.
- If input power loss occurs, operation will resume within five seconds after restoration of input power.
- Brightness Steps can be changed in the field (between 3 and 5 Steps). New label required.
- Field upgradeable from L-828 to L-829 with ACE unit.
- Industrial powder coat finish.
- Input lightning protection and output lightning protection included.

2.5 Electrical Supply

Power Input

60Hz, single-phase available in 208, 220, 240, 347, 380 and 480 Vac.

50Hz, single phase available in 208, 220, 230, 240, 380 and 400 Vac (380 and 400 Vac 6.6 A only).

Power Factor*

0.90 minimum for 4kW to 10kW

0.95 minimum for 15kW to 30kW

Efficiency

90% minimum for 4 to 20kW

92% minimum for 30kW

* Tested with 100% resistive load according to FAA AC 150/5345-10 (Current Edition).

2.5.1 Remote Control

120Vac, 50/60Hz or +48Vdc, $\pm 10\%$

2.5.2 Total Harmonic Distortion* (THD)

Current THD: 10% maximum in highest step

Voltage THD: 1.9% maximum in all steps

* Tested with 100% resistive load according to FAA AC150/5345-10 (Latest Edition).

2.5.3 Theory of Operation Introduction

Solid-state control and monitoring feedback circuitry is used for output current regulation of $\pm 3\%$ and input voltage variation of -5% to +10% of nominal. If the load on the regulator varies, a gating signal controlled by feedback circuitry changes the control circuit conduction angle in order to control the power to the main transformer. This maintains the transformer's output current at the preset brightness level.

For more theory of operation see: "Theory of Operation" on page 9.

2.6 ACE Unit

The ACE2™ unit provides L-829 monitoring and optional megging or CCR input monitoring capability. Each unit is installed locally at each CCR that requires remote control and/or monitoring within the airfield lighting electrical vault. Optional CCR input monitoring monitors the following:

- CCR input current
- CCR input voltage
- CCR input volt-amps (VA)
- CCR input power (watts)
- CCR input power factor
- CCR % efficiency

The ACE unit is also a component of ADB Safegate's distributed control and monitoring system. Each unit can be easily connected to an Airport Lighting Control & Monitoring System (ALCMS) by simply adding redundant communication wires. See ADB Safegate ACE catalog sheet for additional information. See www.adbsafegate.com

2.7 Environmental Operating Conditions

- Temperature: -40°C to +55°C (-40°F to +131°F)
- Humidity: 10 to 95%
- Altitude: 0 to 6,600 ft (2,000 m)

2.7.1 Monitoring Option

See Figure 1.

Figure 1: CCT Ordering Codes

Monitoring Options (See Application Notes)

- 0 = None (Standard L-828)
- 1 = ALCMS Scanning Monitor Interface
- 2 = ALCMS Scanning Monitor Ready
- 3 = L-829 Monitoring (ACE)
- 4 = Insulation Resistance Monitoring System (IRMS) Ready
- 5 = L-829 Monitoring (ACE) and IRMS Ready
- 6 = L-828 with Digital Power Meter

2.7.2 Application Notes

0 None Standard

L-828 supplied with analog ammeter

1 ALCMS Scanning Monitor (SMI)

The SMI option adds Primary Power and Remote/Local monitoring relays. Dry relay Interface contacts are connected to a dedicated terminal block for each monitored point. Typical application: connecting ADB L-828 CCR to ALCMS or L-827 that is manufactured by others. Note that this option does not provide dedicated output current or voltage transformers.

2 ALCMS Scanning Monitor

The SMR option adds several monitoring relays (including Primary Power and Remote/Ready (SMR) Local) and also CCR output current and voltage transformers. All monitored signals are connected to a dedicated terminal block. Application only for connecting ADB L-828 CCR to ADB Gen I/II ALCMS scanning monitoring system.

3 L-829 Monitoring (ACE™)

Includes FAA L-829 monitoring equipment.

If application is for connection to ADB L-890 **ALCMS**: Add a "/A" to end of Ordering Code. The ACE unit will then be programmed to provide monitoring data via dual redundant communication links. If application is for a stand-alone L-829 CCR: Ordering Code is not changed. The ACE unit is programmed to activate a dry contact closure if a fault is present. The fault alarm can then be connected to any external monitoring system.

4 Insulation Resistance Monitoring System (IRMS) Ready

This option adds an IRMS board in the CCR. Application: connection to externally mounted ADB ACE unit.

5 L-829 Monitoring (ACE) Includes FAA L-829 and IRMS equipment and IRMS

- If application is for connection to ADB L-890 **ALCMS**: Add a "/A" to end of Ordering Code. The ACE unit will then be programmed to provide monitoring data via dual redundant communication links.
- If application is for a stand-alone L-829 CCR with Insulation Resistance Monitoring: Ordering Code is not changed. The ACE unit is programmed to activate a dry contact closure if a fault is present. The fault alarm can then be connected to any external monitoring system.

6 L-828 with Digital Power Meter

This option replaces the analog ammeter with a Digital Power Meter. The Digital Power Meter is used on L-828 CCRs to indicate True RMS output current, voltage, VA, and watts. It can also be set to activate an alarm if there is a 10% or 15% drop in the load (Low VA).

2.8 Theory of Operation

This subsection describes the L-828 CCR theory of operation.

2.8.1 Power Circuit

See Figure 2. Constant voltage input lines are fed through an SCR to a power transformer (T1). The output of T1 feeds a field circuit with a constant current level set by switch 1. The CCT control PCB monitors the field current through a high voltage current transformer (T2) and regulates the field current by switching the SCR on and off as needed to maintain the desired current.

2.8.2 Output Measurement

The output current flows through the current transformer T2. T2 provides feedback to the CCT Control PCB board on the actual current output to the airfield series circuit and to a true-rms-reading ammeter mounted onto the front panel to indicate output current.

2.8.3 CCT Control PCB

See Figure 5. This subsection describes the board level circuitry found on the CCT Control PCB.

Figure 2: L-828 CCR Power Circuit Block Diagram

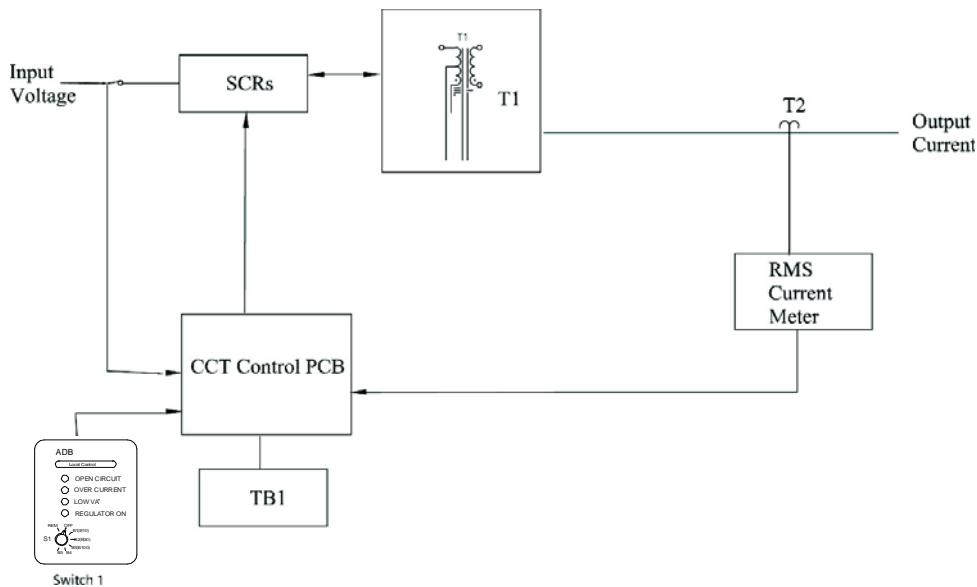

2.8.3.1 URC PCB Inputs/Outputs

The URC receives the inputs listed below. See Figure 5 in this section and Figure 1 and Figure 3 in the “Schematics” section.

- Local control signals from the front panel rotary switch.
- Remote control signals from a remote control terminal block located in the L-828 chassis (120Vac/48Vdc) (TB1).
- A current proportional to the output current from a current transformer (T5).
- Phase angle reference voltage derived from the input voltage.
- 24 Vac center tapped supply voltage from T4.
- The URC provides the outputs listed below.
- A contact to complete the input contactor K1 coil circuit.
- A contact to enable the Remote CCI voltage at TB1.
- Gate drive signals to the SCR block used to regulate the output current.

2.8.4 Output Current Monitor Circuitry

The system output current is sensed by a current transformer (T2) whose secondary is connected to J5-1 and J5-2 on the CCT Control PCB board. For the 6.6 amp regulator, T5 provides a 100:1 step-down of the feedback current. For 20 A regulators, this ratio is 300:1. Output current steps 1-5 would correspond to voltage levels of 420, 510, 615, 780, and 990 millivolts respectively.

2.8.5 Local Control Position Detection

Local control position detection is accomplished by using a rotary switch mounted on the front door of the CCR. See Figure 3.

2.8.6 Contactor Drive

The contactor drive circuit on the CCT Control PCB pulls in the main contactor K2 by shorting points J3-7 to J3-8.

2.8.7 Remote Control Position Detection

When the local control signal to the micro-controller indicates "remote" the remote control circuitry is active, providing 120VAC to the CCI connection on TB1. The remote control inputs incorporate surge suppression and are optically isolated from the rest of the PCB.

2.8.8 Fault Protection

This subsection describes CCT fault protection.

Overcurrent Protection

The micro-controller detects an over current condition by comparing the output current to a preset value. If the output current exceeds this value the controller will shut the regulator down by removing drive to the input contactor. This contactor will remain de-energized until the controller is reset either by selecting the OFF position (remotely or locally) or cycling the input power off for a minimum of 2 seconds and then back on. The control board will not recognize momentary over currents caused by load switching or other transient conditions.

Open Circuit Protection

The micro-controller detects an open circuit by the absence of current in the regulator output (this will also detect an open or shorted current transformer). If the output current is less than 1.5 amps, the controller will shut the current regulator down within one second by removing drive to the input contactor. This contactor will remain de-energized until the controller is reset either by selecting the OFF position (remotely or locally) or cycling the input power off for a minimum of 2 seconds and then back on.

2.9 L-828 CCR

See Figure 3. This subsection describes the L-828 CCR. The L-828 uses a CCT Control PCB to provide regulator and control functions.

NOTE: Figure 3 shows a CCT 15 kW/6.6 A L-828 CCR. The other L-828 CCRs (4, 7.5, 10, 20-30 kW/6.6 A/20 A) may differ in size and appearance.

Figure 3: L-828 CCR (4 -30kW/6.6 A)



1. Ammeter (shown) or Digital Power Meter
2. Rotary Switch

The L-828 CCRs are designed to:

- Supply three or five precision output current levels (6.6 A/20 A maximum) to power airport series lighting circuits on runways and taxiways.
- Accurately regulate the output current to within $\pm 1\%$ of the adjustable nominal levels from no load to full load and with input voltage variations of -5% to +10% of nominal.
- Maintain the nominal output current levels even when 30 percent of the isolation transformers in the series lighting circuit supplied by the regulator have open secondaries.

2.10 L-829 CCR

See Figure 4. This subsection describes the L-829 CCR. The L-829 uses a CCT Control PCB to provide regulator and control functions. It also uses the Advanced Control Equipment (ACE™ or ACE2™) for control and monitoring functions.

NOTE: Figure 4 shows a L-829 (15 kW/6.6 A) CCR. The other L-829 CCRs (4, 7.5, 10, 20-30 kW/6.6 A/20 A) may differ in size and appearance.

Figure 4: L-829 CCR with ACE

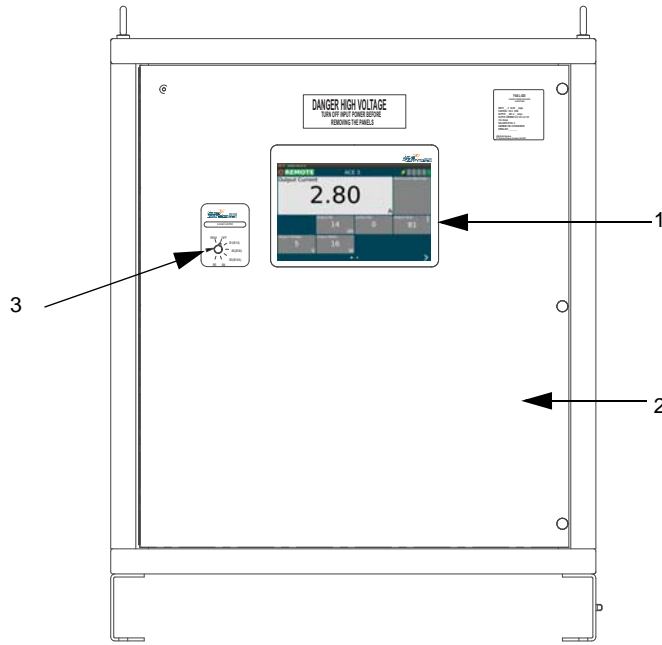

- 1 ACE Front Panel Display
- 2 L-829 CCR
- 3 Rotary Switch

2.11 CCT Control Board

See Figure 5 and Figure 6 below. The CCT Control Board is a PC board that is designed to provide all regulator and control functions for Thyristor Controlled L-828/L-829 CCRs manufactured by ADB Safegate. This is accomplished with an 8-bit embedded microcontroller and interface circuitry contained on a single through-hole type printed circuit board. The CCT Control PCB performs the functions listed below.

- Produces SCR drive signals in accordance with the desired output current setting.
- Detects an overcurrent, or open circuit, and switches the constant current regulator off.
- When in Remote mode, enables the CCI to provide 120 Vac at 50 W. The CCI is the Remote power control source.

Figure 5: CCT Control PCB (44D1475)

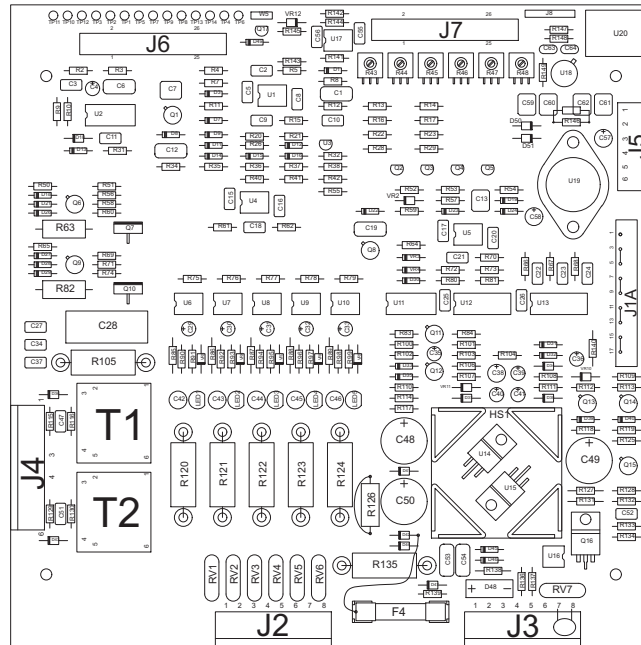

Figure 6: CCT Control PCB (44A6546)



2.11.1 L-829 Advanced Control Equipment (ACE)

See Figure 4 and Figure 7. The L-829 ACE™ control and monitoring unit consists of an integrated control unit that is interfaced to each CCR either internally or within a small external enclosure. The ACE printed circuit boards are mounted inside a small and rugged environmental enclosure that is directly attached to the door of the L-829 CCR. The ACE consists of microprocessor-based module(s) that processes communication, control commands, input/output interface, and failsafe functionality for controlled elements in the airfield lighting vault.

Figure 7: ACE Control and Monitor Boards

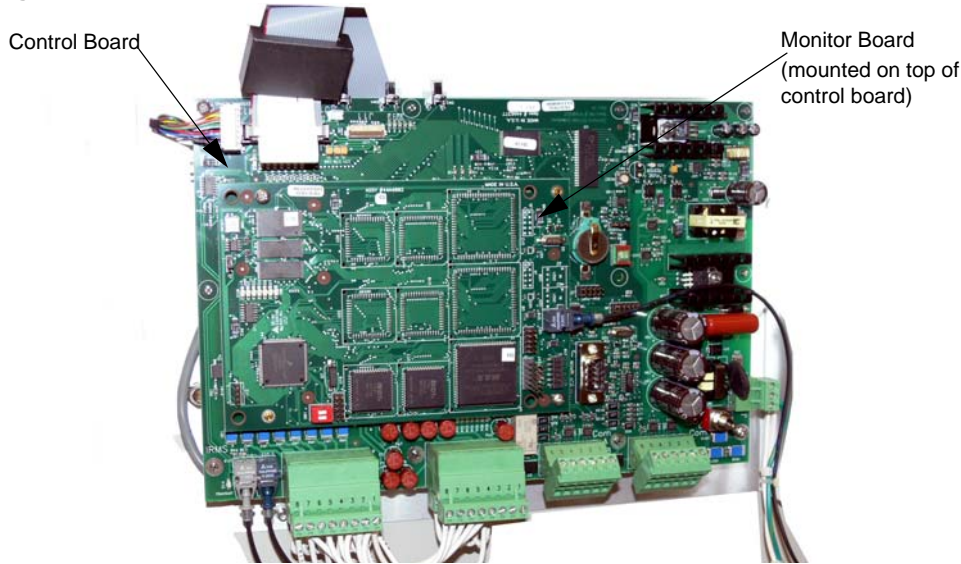

For more information about the ACE, see:

- Advanced Control Equipment (ACE) manual or the Advanced Control Equipment (ACE) manual. See www.adbsafegate.com
- ACE Programming manual. See www.adbsafegate.com

2.12 L-828/L-829 CCR Monitoring Options

The L-829 CCR monitoring options include the Insulation Resistance Monitoring System (IRMS), Scanning Monitor Interface (SMI), and Scanning Monitor Ready (SMR).

2.12.1 Optional Insulation Resistance Monitoring System

The IRMS is used only on the L-829. It performs scheduled cable insulation resistance measurements and can also perform manually requested measurements. IRMS provides the ability for monitoring the long-term degradation of the airfield series circuit cabling and showing the results on the L-829 CCR front display panel.



WARNING

When servicing a regulator equipped with an IRMS module, be sure that power to the IRMS is disconnected by powering down the CCR before touching the IRMS board, or any of the high voltage components or wires.

2.12.2 Optional Scanning Monitor Interface

The scanning monitor interface is a relay assembly that can be mounted internally to the front panel of the CCR. The relay assembly consists of four relays and sockets. The relay assembly is used to generate feedback signals concerning the CCRs operation to the Remote Multiplexer. The relay assembly generates feed back for the following signals: Remote/local status, commanded ON status, regulator running status, and primary power status.

2.12.3 Optional Scanning Monitor Ready

The scanning monitor ready includes the scanning monitor interface plus one current transformer (CT) and one potential transformer (PT). It also has resistor loads, and a fuse in the potential transformer secondary. Differential signals presenting the actual series circuit voltage and current are transmitted to the scanning monitor system two-conductor shielded cables.

2.13 Optional Series Cutout Type SCO

The series cutout Type SCO is often used at airports having a large number of series circuits to isolate the series circuit from the CCR during maintenance or testing operations. It also allows manual measurement of resistance of the series circuit to ground without disconnecting the series cable. The SCO cutout has a nominal working voltage of 5 kV and a nominal carrying current capacity of 20 amps AC.

NOTE: For more information refer to the SCO Cutout manual 96A0294 or the ALSC Manual 96A0490. See www.adbsafegate.com

2.14 L-828 CCRs (4-70 kW 6.6 A/ 20 A): Required Equipment

Refer to Table 1 for required equipment that is supplied.

Refer to Table 2 for required equipment that is not supplied.

Refer to Figure 1 for ordering information.

Table 1: Required Equipment Supplied

Description	Quantity
L-828/L-829 constant current regulator	As Req'd on Order
Instruction manual	1 per CCR on Order

Table 2: Required Equipment Not Supplied

Description	Quantity
Input power wire. Refer to Table 3.	As required
Remote control wire, AWG 18 minimum, AWG 14 maximum	As required
Ground wire, AWG 8 minimum (6.6 A); AWG 6 minimum (20 A)	As required
Output load wire, AWG 6 minimum, 5000 Vac, L-824 type (6.6 A); AWG 8 minimum (20 A)	As required
Shorting jumper wire, AWG 8 minimum	As required
Disconnect switch or main circuit breaker	1
Voltmeter, 60 Vdc full scale	1
Ammeter, true-rms-reading, 9 A maximum scale	1
Inductive-type current probe	1
Ohmmeter	1
Mounting bolts, ½-16 x 1-1/2 in. long, ½ STD washers, and lock washers	4

2.15 Input Wire Size

Table 3 refers to recommended input power supply wire size for each regulator power rating dependent on the input voltage. This recommendation is based on 75°C rated copper wire per NEC Table 310.16.

Table 3: Recommended Input Wiring Rating

Power Rating	208 Vac	220 Vac	240 Vac	347 Vac	380, 400 Vac	480 Vac
4 kW	AWG 10	AWG 10	AWG 10*	AWG 12*	AWG 12*	AWG 14*
7.5 kW	AWG 6	AWG 8	AWG 8	AWG 8	AWG 8	AWG 10*
10 kW	AWG 4	AWG 6	AWG 6	AWG 8	AWG 8	AWG 10
15 kW	AWG 3	AWG 3	AWG 4	AWG 6	AWG 6	AWG 8
20 kW	AWG 2/0	AWG 1/0	AWG 2	AWG 4	AWG 4	AWG 6
30 kW	AWG 3/0	AWG 3/0	AWG 2/0	AWG 2	AWG 2	AWG 4

*Increased 1 wire size to comply with small conductor limits in NEC 240.4.D.

2.16 Input Power Breaker Sizing

It is recommended that the circuit breaker on the input power supply lines have a rating of 125% of the CCR's input current, as given in Table 4, unless local codes require a different rating technique. Refer to the CCR's nameplate for the kW rating and input voltage to determine the actual input current from Table 4. If no standard-size circuit breaker exists at the 125% value, use the next larger standard-size circuit breaker.

NOTE: The currents listed in Table 4 represent actual input currents assuming the worst case limits of AC 150/5345-10 for power factor, efficiency, and number of required lamps out.

Table 4: CCR Input Voltage and Current for the CCR Power Ratings

Power Rating	208 Vac	220 Vac	240 Vac	347 Vac	380 Vac	400 Vac	480 Vac
4 kW	27 A	26 A	24 A	16 A	15 A	14 A	12 A
7.5 kW	51 A	48 A	44 A	31 A	28 A	26 A	22 A
10 kW	68 A	65 A	59 A	41 A	37 A	35 A	30 A
15 kW	97 A	92 A	84 A	58 A	53 A	50 A	42 A
20 kW	129 A	122 A	112 A	78 A	71 A	67 A	56 A
30 kW	190 A	179 A	164 A	114 A	104 A	98 A	82 A

2.17 Specifications

This subsection provides specifications for L-828/L-829 CCR (4-70 kW 6.6 A/20 A).

Table 5: Class, Style and Power Ratings

Class	L-828/L-829 CCR Max Output Current	Style	Brightness Steps	Nominal Output Current	Power Ratings
1	6.6 A	1	3	4.8 A, 5.5 A, 6.6 A	4, 7.5, 10, 15, 20 and 30 kW
		2	5	2.8 A, 3.4 A, 4.1 A, 5.2 A, 6.6 A	
2	20 A	2	5	8.5 A, 10.3 A, 12.4 A, 15.8 A, 20 A	15, 20, 30 kW

Table 6: Power Factor

CCR	Power Factor
4 - 10 kW	0.90 minimum
15 - 30 kW	0.95 minimum

2.17.1 Efficiency

The efficiency of the regulator operated with rated input voltage into a full load having unity power factor is not less than the value shown in Table 6.

Table 7: Efficiency

CCR	Efficiency
4-20 kW	0.90 minimum
30 kW	0.92 minimum

2.17.2 Reactive Loading

The CCR maintains the output current within the limits of Table 8 for all brightness steps when the load is connected via isolating transformers, and the secondaries of 30 percent of the transformers become open-circuited. The load before opening the isolation transformer secondaries may be any value from half to full load. For regulators less than 10 kW loaded as specified above, the current remains below 6.8 amperes for the 100 percent brightness step.

Table 8: Output Current and Limits

Class	Style	Step	Nominal output amperes (A) root mean square (RMS)	Allowable range (A RMS)
1	1	B100	6.6	6.5 - 6.7
		B30	5.5	5.4 - 5.6
		B10	4.8	4.7 - 4.9
1	2	B5	6.6	6.5 - 6.7
		B4	5.2	5.1 - 5.3
		B3	4.1	4.0 - 4.2
		B2	3.4	3.3 - 3.5
		B1	2.8	2.7 - 2.9

2.17.3 Resistive Loading

The regulator maintains the output current within the limits of Table 8 while powering any load between no load (or short circuit) and full load. For regulators 10 kW or larger, the regulation is maintained over the full range of environmental conditions specified in this section and for the input voltages specified in Table 4. For regulators less than 10 kW, the regulation is provided at nominal input voltage for all brightness steps.

2.17.4 Regulation

Refer to Table 8 for output current limits. Current regulation is obtained under the conditions listed in *Environmental Operating Conditions*.

2.17.5 Environmental Operating Conditions

The L-828 CCRs are designed for indoor use only in an area with adequate ventilation for cooling the constant current regulator. The environmental operating conditions include temperature range, relative humidity, and altitude.

Table 9: Environmental Operating Conditions

Temperature Range		Relative Humidity	Altitude
Without monitoring circuitry	With monitoring circuitry		
-40 to +55 °C (-40 to +131 °F)	0 to +55 °C (-18 to +131 °F)	10 to 95% (non-condensing)	Sea level to 6,600 ft (2000 m)

2.17.6 Protection Devices

L-828 CCRs have the following protection devices:

- Output open-circuit protection.
- Output overcurrent protection.
- Lightning arrestors on output terminals and bushings.
- Lightning arrestors on input terminals.
- Fuse protection of AC supply voltage of the CCT Control PCB and brightness control voltage for Remote control.

2.17.6.1 Open-Circuit Protection

The regulator includes an open-circuit protective device to open the primary switch within 2 seconds after an open circuit occurs in the secondary. The device resets within 2 seconds after the control switch is turned off and re-energized, and cannot be tripped by switching the load circuits or other transients.

2.17.6.2 Overcurrent Protection

Regulators include an overcurrent protective device that opens the primary switch when the output current exceeds the 100 percent current (6.6 A) by 5 percent. The device operates within 5 seconds after an overcurrent of 5 percent and within 1 second after an overcurrent of 25 percent. The device resets within 2 seconds after the control switch is turned off and re-energized. The overcurrent protection cannot be activated by a momentary (0.25 second) overcurrent caused by switching the load circuits and other transients.

2.17.7 Input Voltage

Input voltage is single phase 50 or 60 Hz ac. Regulators operate as required (see subsections *Resistive Loading* and *Reactive Loading* in this section) when the input voltage is anywhere between 95 and 110 percent of the nominal value. The regulator is designed to withstand momentary voltages up to 120 percent of nominal input voltage without shutting off or being damaged by such overvoltage so long as the duration of overvoltage excursions are not longer than 50 milliseconds and do not occur more than once per minute.

Thyristor Regulators are configured for either 50 or 60 Hz operation at the factory. Contact ADB for additional information or changing the input frequency.

2.17.7.1 Built-In True-rms-Reading Ammeter, L-828 only

For the L-828 only, a flush-mounted true-rms-reading ammeter mounted on the front of the input module PCB indicates the output current. The meter accuracy is ± 3.0 percent of the maximum output current.

2.17.7.2 Rating and Input Voltage

Table 10: Rating and Input Voltage

Rating	Input Voltage
4, 7.5, 10, 15, 20, 30 kW	208, 220, 240, 347, 380, 480 Vac, -5 to +10%; 60 Hz 50Hz, single phase available in 208, 220, 230, 240, 380 and 400 Vac (380 and 400 Vac 6.6 A only)

2.17.8 Temperature Rise

The temperature rise of the transforming portion of the regulator is in accordance with ANSI C57.12.91 for air-cooled regulators.

2.17.9 Dimensions

Table 11: L-828/L-829 CCR Dimensions (240/480 V)

Rating	H in. (mm)	W in. (mm)	D in. (mm)
4, 7.5, 10 kW	33 (838.2)	24 (609.6)	25 (635.0)
15, 20, 30 kW	36 (914.4)	29 (726.6)	30 (762.0)

Figure 8: CCT L-828/L-829 CCR Dimensions

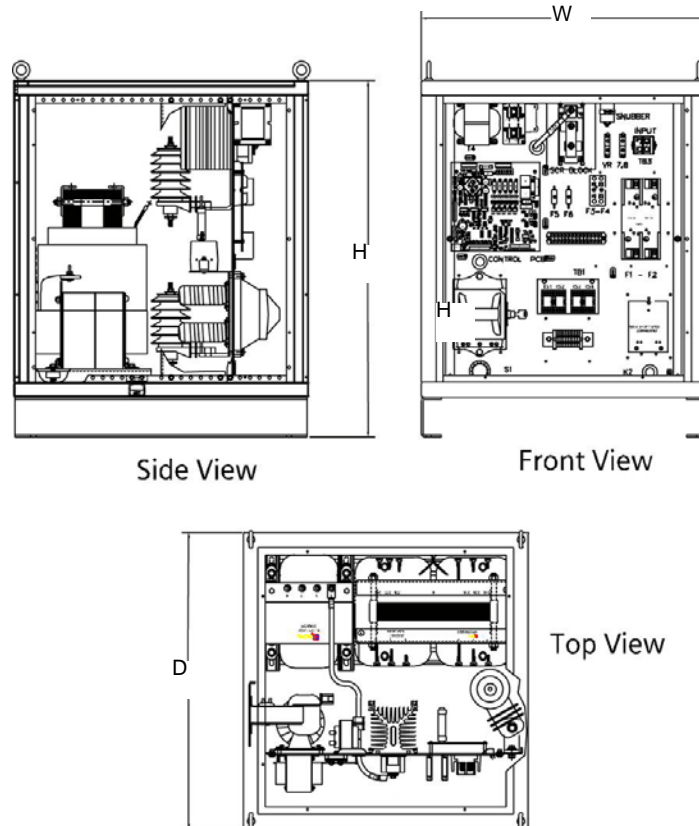

2.17.10 Weight

Refer to Table 12 for weight of all L-828/L-829 CCRs.

Table 12: L-828/L829 CCR Weight

Power Rating	Estimated Weight lb (kg)
30 kW	705 (320.0)
20 kW	553 (250.9)
15 kW	470 (213.5)
10 kW	302 (137.0)
7.5 kW	265 (120.2)
4 kW	215 (91.5)

3.0 CCT Installation

L-828 / L-829 CCR Installation



WARNING

Read installation instructions in their entirety before starting installation.

- Refer to the FAA Advisory Circular AC 150/5340-26, Maintenance of Airport Visual Aids Facilities, for instructions on safety precautions.
 - Observe all safety regulations. To avoid injuries, always disconnect power before making any wiring connections or touching any parts.
 - Become familiar with the general safety instructions in this section of the manual before installing, operating, maintaining or repairing this equipment.
 - Read and carefully follow the instructions throughout this manual for performing specific tasks and working with specific equipment.
 - Make this manual available to personnel installing, operating, maintaining or repairing this equipment.
 - Follow all applicable safety procedures required by your company, industry standards and government or other regulatory agencies.
 - CCT Control PCB is static-sensitive. Must be grounded when handling PCB.
 - Route electrical wiring along a protected path. Make sure they will not be damaged by moving equipment.
 - Protect components from damage, wear, and harsh environment conditions.
 - Allow ample room for maintenance, panel accessibility, and cover removal.
 - Protect equipment with safety devices as specified by applicable safety regulations.
 - If safety devices must be removed for installation, install them immediately after the work is completed and check them for proper functioning prior to returning power to the circuit.
-

This section provides instructions for installing L-828/L-829 constant current regulators (CCRs) (4-30kW/6.6 A). Refer to the airport project plans and specifications for the specific installation instructions.

3.1 Unpacking

The equipment is shipped ready for installation. Handle equipment very carefully to prevent component damage. Unpack the carton upon receipt and check the contents and their condition. Note any exterior damage to the carton that might lead to detection of equipment damage.

If you note any damage to any equipment, file a claim with the carrier immediately. The carrier may need to inspect the equipment.

NOTE: Take care to maintain the unit in an upright position when handling the regulator.

3.2 Installation

Recommend lifting for the 4 thru 30kW regulators is to use a forklift from underneath the CCR frame. Lifting points, four 3/4-inch ID eye-bolts on the top corners of the CCR frame, are provided per FAA specifications. If lifting eye bolts are used, use either a portable hoist and sling(s) or sling(s) attached from forks on forklift. See Table 12, for CCT Weight before lifting.



WARNING

Read installation instructions in their entirety before starting installation.

- If lift points (eye bolts) are used, lift straight up. Side loading on the eye bolts may cause them to bend.
-

Place the regulator inside a well ventilated room with sufficient clearance for personnel to inspect and maintain the unit.

3.2.1 Wiring Connections and Startup



WARNING

Read installation instructions in their entirety before starting installation.

- Installation and operation of the CCR should be performed by personnel qualified to work on high voltage equipment. The high voltage involved with the unit makes it potentially dangerous and may be lethal if contacted by operating personnel.
- Place wiring for output, input, and remote control only on the right side of the CCR to prevent damage to the PCB that is located on the front Left side of the enclosure. If output, input, and remote control wiring must enter from the left side of the enclosure then wiring must be then routed through conduit where it passes the PCB area. See Figure 1.

To install wiring, perform the following procedure:

1. Verify the input supply voltage corresponds to the voltage rating on the nameplate of the regulator.
2. Make sure the front panel rotary selector switch is set to the OFF position.
3. Ground the regulator by making an adequate ground wire (AWG 6 or larger) connection to the external earth ground lug on the regulator.
4. An appropriate disconnect-type cutout or circuit breaker shall be provided outside the regulator for the input power supply lines.
5. Short-circuit the output terminals TB2-1, TB2-2 using 8 AWG minimum wire to avoid lamp destruction in case of excessive current output.
6. Refer to Table 3 for the recommended input wire. Connect the power supply lines from the disconnect switch or main circuit breaker to the CCR input fuse block F1/F2 or terminal block TB3. Tighten all connections.

Figure 1: Wiring on Right Side of CCR



1. Front of CCR
2. Place Conduit and Wire on Right Side of CCR
7. Engage main circuit breaker or disconnect switch to energize the regulator.
8. Turn front panel rotary selector switch to all brightness steps, and verify that current values on the panel ammeter correspond to those in Table 8 for each brightness step.
9. Disengage the main current breaker or disconnect switch to de-energize the regulator.
10. Turn the rotary selector switch to OFF.
11. Connect remote control lines, if required, to remote control terminal block TB1. Use AWG 18, 300 V wire or larger for 120 Vac signals. See Figure 1 and Figure 3 in the “Schematics” section for remote control connections.

NOTE: If the ADB Safegate Advanced Control Equipment (ACE) is used with the Ferroresonant L-828 CCR, refer to the Advanced Control Equipment manual (ACE) manual for wiring connections to remote control.

Table 1 and Table 2 provide the necessary connections for remote control. Terminal B1 (B10) does not need to be wired. Brightness step B1 (B10) occurs when the regulator is switched on.

Table 1: Remote Control Connections (3-Step/6.6 A)

For this remote intensity step...	Connect CCI to...
LOW (4.8 A)	CC
MEDIUM (5.5 A)	CC, B30
HIGH (6.6 A)	CC, B100
OFF	Not applicable

Table 2: Remote Control Connections (5-Step/6.6 A)

For this remote intensity step...	Connect CCI to...
2.8 A	CC
3.4 A	CC, B2
4.1 A	CC, B3
5.2 A	CC, B4
6.6 A	CC, B5
OFF	Not applicable

12. Make sure wiring connections are tight and no wires are shorting across each other.

CAUTION

- Read installation instructions in their entirety before starting installation.
- Incorrect wiring can damage regulator. Double check all connections.

13. Energize regulator and set rotary selector switch to REM. Operate the CCR by remote control, and verify correct current levels are obtained on all brightness steps.

14. Turn rotary selector switch to OFF and de-energize regulator (disengage disconnect switch or main circuit breaker). Remove short-circuit link between output terminals TB2-1 and TB2-2.

15. Connect the 6.6 A or 20 A series lighting circuit to the output terminals/ bushings and tighten all connections.

Table 3: Input/Output Connections

CCR Size	Input Location	Output Location
4 thru 30kW with SCO	Top of each Fuse Block front of component plate right hand side	Bottom of SCO
CCT 20kW, 208/220 V CCT 30kW, 208/220 V		Lightning Arrestors (VR1 and VR2) on Back of component plate
CCT 4, 7.5, 10 kW	Terminal Block (black) Front of component plate right hand side	Lightning Arrestors (VR1 and VR2) on Back of component plate
CCT 15,20,30 kW	Terminal Block (white) Front of component plate right hand side Top of each Fuse Block front of component plate right hand side	Lightning Arrestors (VR1 and VR2) on Back of component plate

3.3 Stacking CCR's (Optional)**CAUTION**

- Read installation instructions in their entirety before starting installation.
- Before stacking CCRs larger than 10 kW or stacking more than 2 CCRs, contact the ADB Safegate Sales Department.

To stack CCRs, perform the following procedure:

1. Remove the four 1/2 x 3-3/4 HILTI anchor bolts with 4 nuts and lock washers for anchoring the CCRs to concrete, and the four 1/2-13 x 3/4 hex head bolts and 1/2 split lock washers from the stacking kit (Part Number 94A0475/SS, /MS, /MM).
2. See Figure 2 for anchor bolt template. Use the four 1/2 x 3.75 Lg HILTI anchor bolts with 4 nuts and lock washers to anchor the CCR to the concrete floor.

NOTE: Make sure the clearance behind the CCR is far enough from the wall for easy access to the regulator.

Figure 2: Anchor Bolt Template

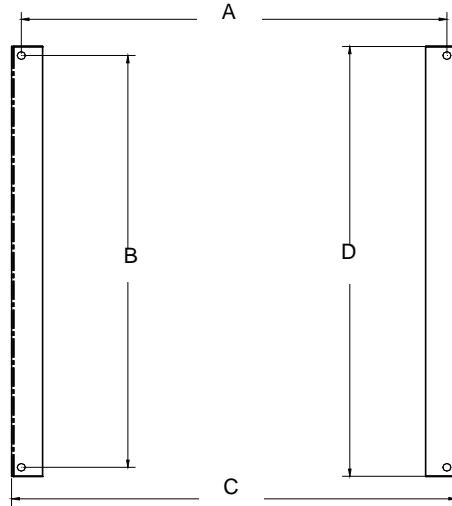
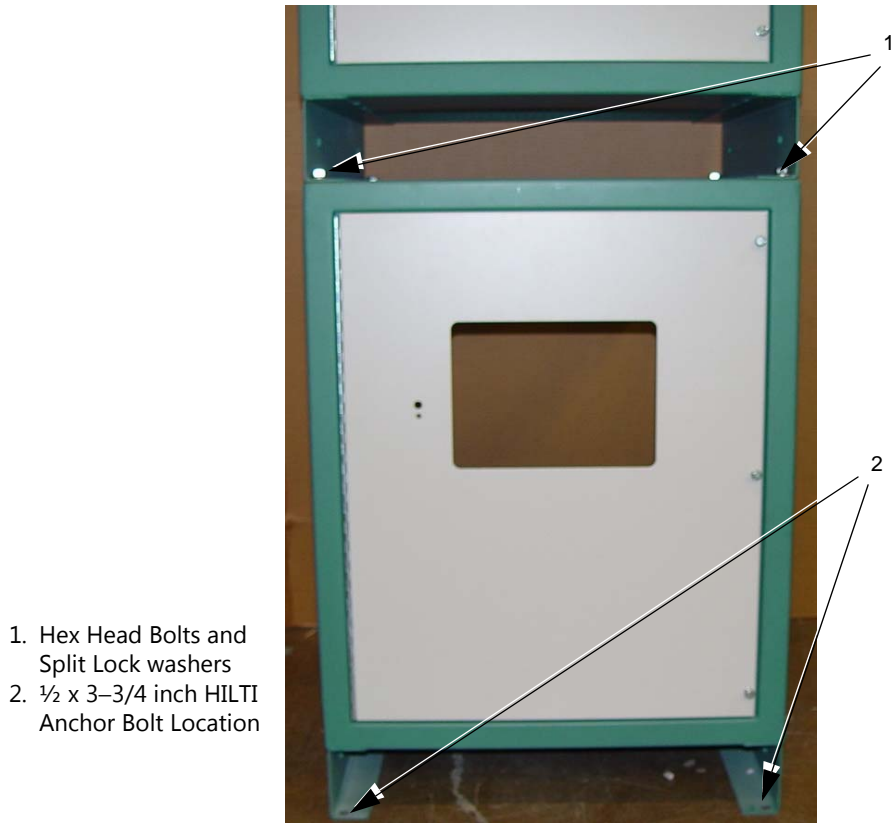

Table 4: Bolt patterns for the 2 CCR sizes

CCR	A	B	C	D
Small	22.50	23.50	23.75	24.75
Medium	27.50	28.50	28.75	29.75

Figure 3: Location of Bolts for Stacking CCRs



3. Remove the 4 eye bolts from the anchored CCR.
4. Stack the second CCR by positioning its 4 holes carefully on top of the holes of the CCR anchored to the concrete floor.
5. Install the 4 hex head bolts and split lock washers (See Figure 4, Item 1 and Figure 5, Item 1).

Figure 4: Stacking Bolt

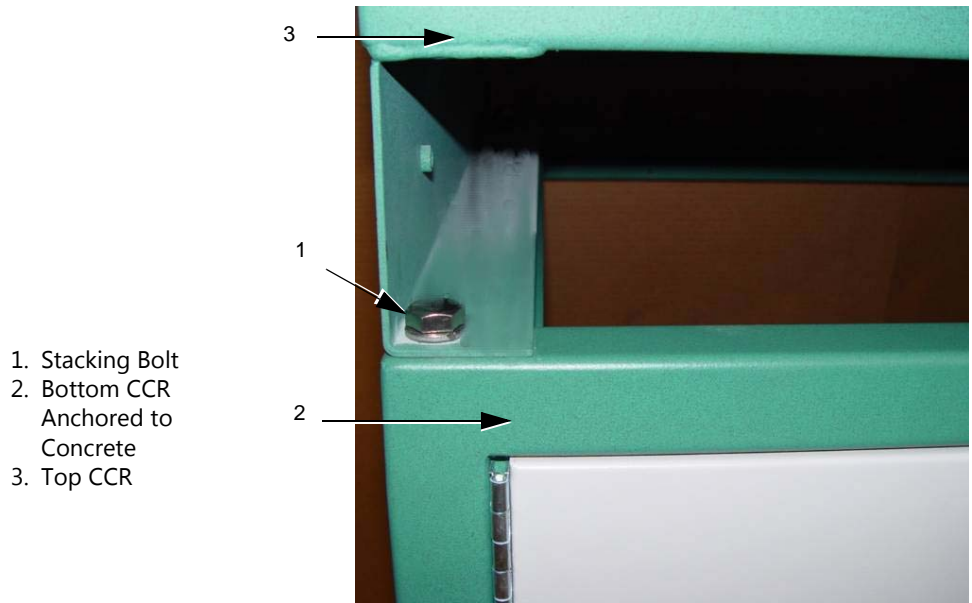

3.4 Frames

Figure 5: Medium Frame Assembly

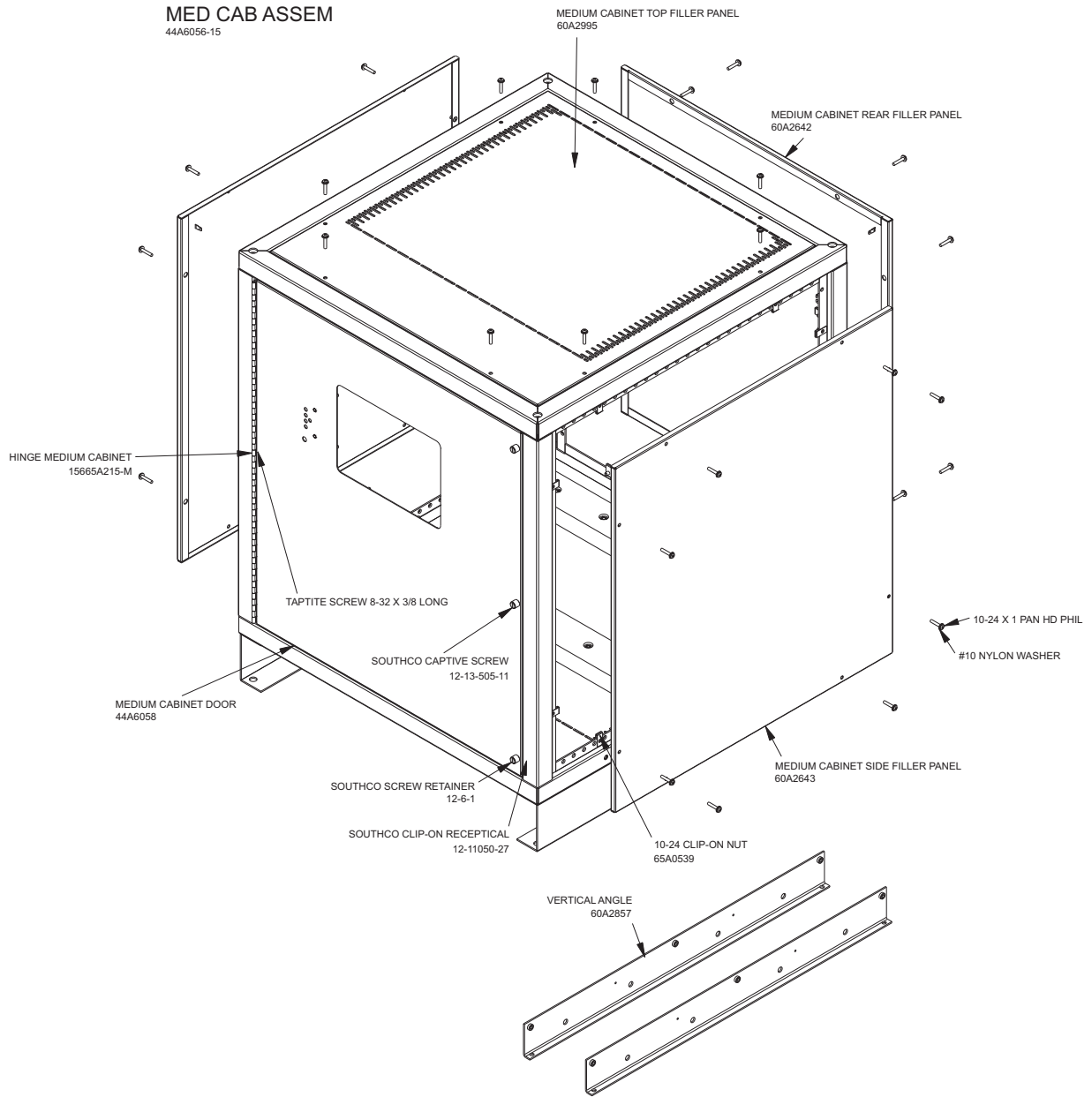

4.0 CCT Operation

WARNING



Read installation instructions in their entirety before starting installation.

- Refer to the FAA Advisory Circular AC 150/5340-26, Maintenance of Airport Visual Aids Facilities, for instructions on safety precautions.
- Observe all safety regulations. To avoid injuries, always disconnect power before making any wiring connections or touching any parts. Refer to FAA Advisory Circular AC 150/5340-26.
- Become familiar with the general safety instructions in this section of the manual before installing, operating, maintaining or repairing this equipment.
- Read and carefully follow the instructions throughout this manual for performing specific tasks and working with specific equipment.
- Contents are static-sensitive. Must be grounded when handling PCBs.

4.1 Introduction

This section provides the operational procedures listed below for the L-828/L-829 constant current regulator (CCR) (4-30 kW).

- CCR control procedures
- CCR shutdown procedures
- CCR adjustment procedures
- SCO cutout working positions

4.2 CCR Control Procedures

This subsection describes the regulator operations in local and remote controls.

4.2.1 Local Control

See Figure 1. Refer to Table 1 and Table 2 for output current when using local control. The front panel rotary selector switch is used for regulator local control. The rotary switch for the 3-step CCR has five positions; the rotary switch for the 5-step has seven positions. The regulator automatically maintains the output current within $\pm 1\%$ of the nominal value for the brightness position selected.

Figure 1: L-828/L-829 Switches

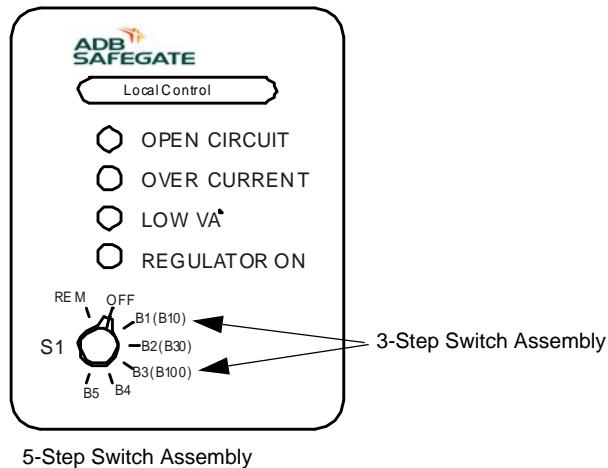

Table 1: Output Current from Rotary Switch (3-Step/6.6 A)

If you set the rotary switch to the following...	The result is...
B10	4.8 A current output
B30	5.5 A current output
B100	6.6 A current output
B4	Not Used/Blocked
B5	Not Used/Blocked

Table 2: Output Current from Rotary Switch (5-Step/6.6 A)

If you set the rotary switch to the following...	The result is...
B1	2.8 A current output
B2	3.4 A current output
B3	4.1 A current output
B4	5.2 A current output
B5	6.6 A current output

4.2.2 Remote Control

See Figure 1. Refer to Table 3 for instructions on how to set up and use remote control.

Table 3: Remote Control

If...	Then...
The rotary switch is set to position REM and remote control wiring is connected to remote control terminal block TB1 on the regulator	Remote control of the regulator is possible. The output current of the regulator will correspond to the brightness setting energized by remote 120 Vac or 48 VDC control signals.
Switch is set to OFF	Remote control signals will not operate the regulator; that is, turn the regulator on to a particular brightness setting or turn the regulator off.
No remote control connections exist on terminal block TB1 (switch is set to REM)	The position REM becomes an additional OFF position; that is, the regulator is de-energized.

4.3 CCR Shutdown Procedure

See Figure 1. To shut down the CCR, set the rotary switch to position OFF.

NOTE: Power to the output terminals is now off, and the regulator cannot be energized by remote control signals. Power is still present on the input power terminals and on the internal control circuitry.

To remove input power, disconnect switch or external circuit breaker.

4.4 CCR Adjustment Procedures

This subsection provides procedures for adjusting output current and overcurrent.

NOTE: The regulator has been adjusted at the factory to provide the nominal output current levels as given in Table 8. If the current level settings need to be adjusted, read the following warning statement before proceeding.

WARNING



- Only personnel qualified to work on high voltage systems should attempt to make any adjustments on the constant current regulator.
- Turn the rotary selector switch on the front panel of the regulator to position OFF. Remove input power before servicing control circuitry.
- Never service the regulator when it is in protective shutdown mode, Remote controls or power fluctuations can restart the regulator.

4.4.1 Output Current Adjustment

To adjust the output current, perform the following procedure:

1. Connect a clamp-on true rms-reading instrument (such as a Fluke 87 multimeter with a current clamp) around one of the output current leads. See Figure 2.

Figure 2: Output Current Clamp

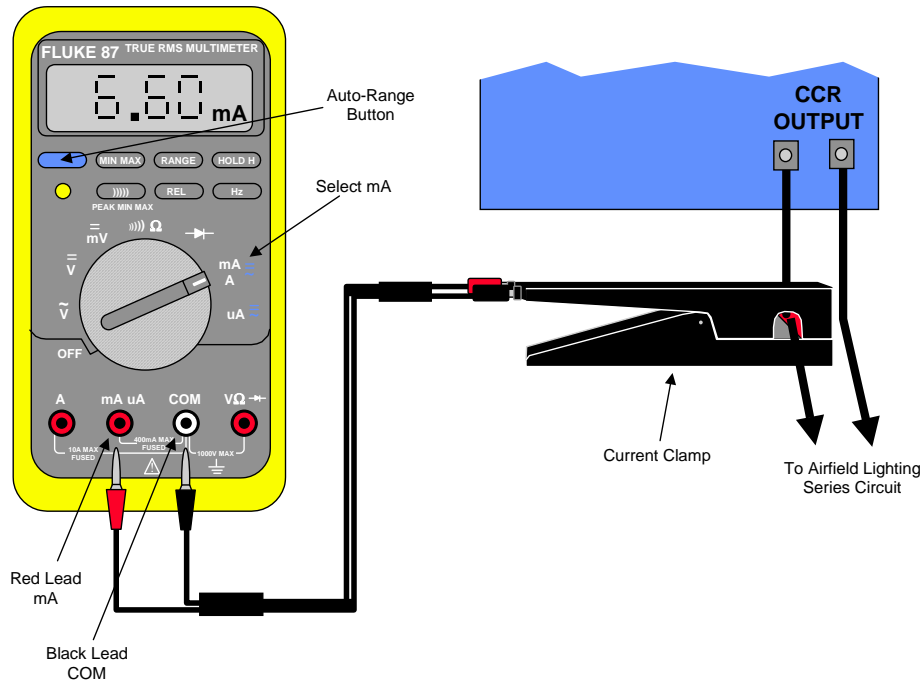

NOTE: Make sure the meter is set on the AC current scale.

Because the output current waveform is not a true sine wave, the ammeter must be of the true-rms (root mean squared) type. Field instruments such as clamp-on ammeters and Simpson voltmeters will give erroneously low readings.

4.4.1.1 Regulator Control Board (44D1475)

To adjust the output current of Regulator Control Board 44D1475, perform the following procedure:

2. Turn on the CCR and set local control switch to the highest intensity step, B5 for 5-step CCR or B100 for a 3-step CCR.

NOTE: The external true-rms ammeter (1) should read 6.60 ± 0.1 amps. If the reading is outside of this range, adjust the Control PCB to obtain 6.60 amps.

On the Regulator Control board 44D1475 Potentiometer R47 is the master reference adjustment. Changing this potentiometer changes the adjustment of potentiometers R48 (8), R46 (6), R45 (5), R44 (4), and R43 (3).

Figure 3: Regulator Control PCB (44D1475)

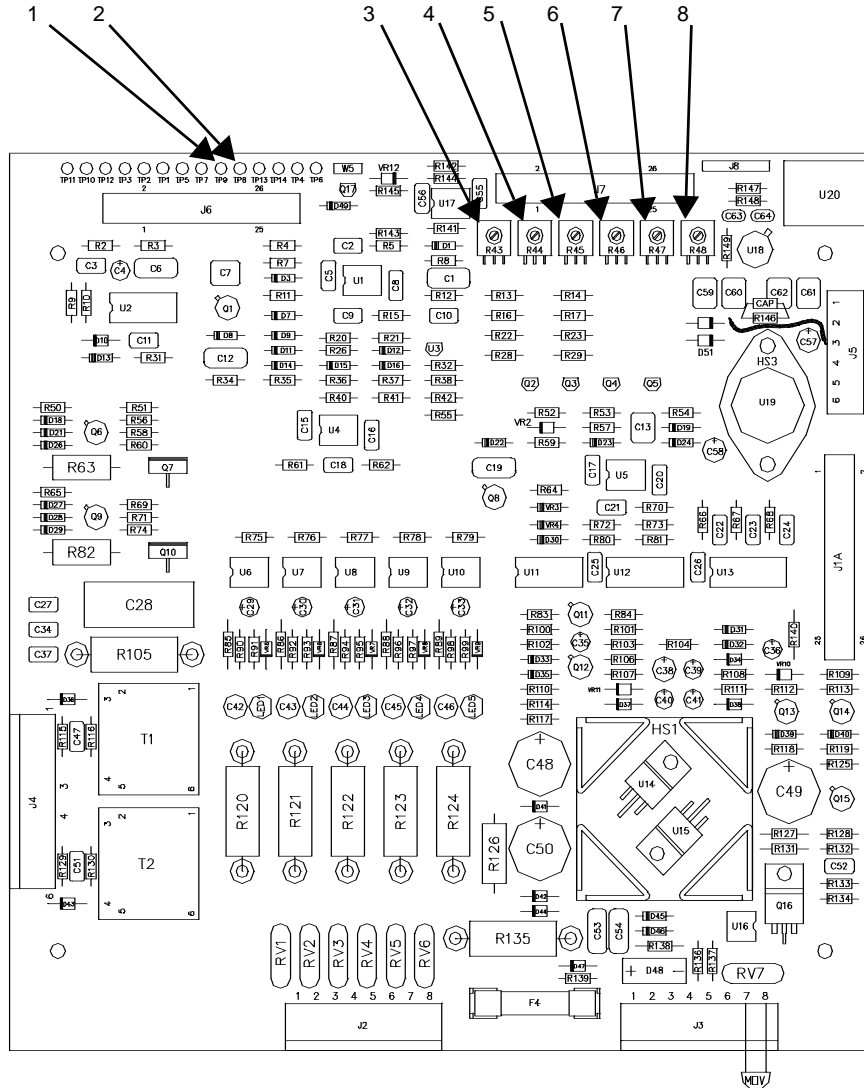

3. Set the local switch to next to the lowest brightness step, and verify that the true-rms ammeter reading corresponds to Table 4 and Table 5. If the reading is not in the current value range given in Table 4 and Table 5, adjust the Regulator Control PCB until the correct current value is obtained.

Table 4: Potentiometers for 3-Step Output Current Levels

CCR S1 Position	Ammeter Reading	Potentiometer (44D1475)
30	5.50	R46
10	4.80	R45

Table 5: Potentiometers for 5-Step Output Current Levels

CCR S1 Position	Ammeter Reading	Potentiometer (44D1475)
4	5.20	R46
3	4.10	R45
2	3.40	R44
1	2.80	R43

-
- Repeat Step 2 for the remaining lower brightness step(s).

NOTE: See Figure 3. On Controller Board 44D1475 Potentiometers R43 (3), R44 (4), R45 (5), R46 (6) have independent circuits, so any adjustments made on these potentiometers will not effect the adjustment of the other three potentiometers.

- When the output current adjustment has been completed, turn off the CCR. Remove shorting cable on output varistors, if used.

NOTE: On a Controller Board 44D1475 Potentiometers R44 (4) and R43 (3) are used only on 5-step CCRs. R44 and 43 have no function on a 3-step CCR.

4.4.1.2 Adjusting Overcurrent Control Board (44D1475)

Before adjusting the over current, set up the regulator and adjust the output current.

To adjust the overcurrent, perform the following procedure:

- See Figure 4. With power off, connect a test lead across TP7 (1) and TP9 (2) on the Control PCB. This will move the trip level for the over current detection threshold from the normal operating point of 6.93 amps to 6.6 amps.
- Turn the local switch to the highest brightness step, B5 for 5-step CCR or B100 for a 3-step CCR. Ammeter should read 6.6 amps.

NOTE: Do not change the adjustment of R47 (7), since this not only will affect the output current of the CCR but the potentiometer adjustment levels for all other current levels.

- Physically center the over current potentiometer R48 (8). While viewing the red over current LED (3) on the control panel, slowly turn R48 (8) clockwise until the LED begins to glow. Then quickly turn control switch S1 (6) to the next lower intensity step. This will turn the LED off because the current level is less.

NOTE: If the potentiometer R48 is turned too far, the CCR will shut down. If this should occur, return potentiometer R48 to the centered position and reset the CCR by momentarily turning off the CCR off and then back on.

- While watching the over current LED, return S1 to the highest intensity step, and time how long it takes for the over current LED indicator to start to glow. It should take 3 ± 1 s.

NOTE: If the LED comes on in less than 2 seconds, turn potentiometer R48 a slightly counterclockwise. If more than 4 seconds are required for the LED to light, turn R48 slightly clockwise. Repeat Step 4 until the correct time period (3 ± 1 s) is obtained.

- Turn off the CCR and remove test leads from TP7 (1) and TP9 (2). The trip level for the over current threshold is now calibrated for 6.93 amps.

4.4.2 Adjusting Output Current (44A6546)

Figure 4: Regulator Control PCB (44A6546)

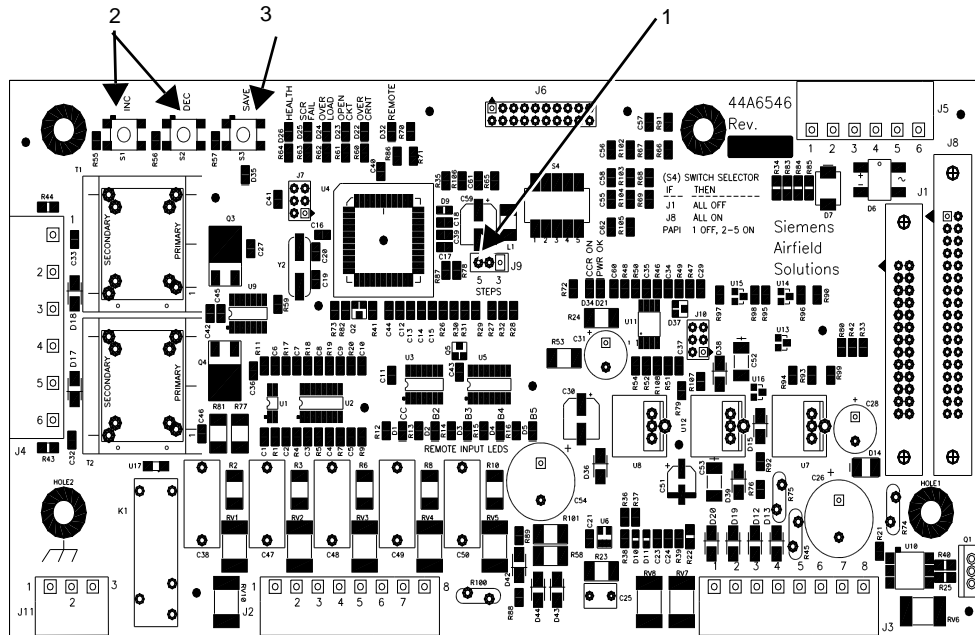

To adjust the output current of Regulator Control Board (44A6546), perform the following procedure:

1. For a CCR, verify that the Control PCB jumper J9 (Figure 4, Item 1) is set to the step setting that matches the CCR (3 or 5-step).
2. Turn on the CCR and set local control switch to the highest intensity step, B5 for 5-step CCR, B100 for a 3-step CCR.
3. The external True-RMS ammeter should read 6.60 ± 0.1 amps. If the reading is outside of this range, adjust the output current with buttons INC and DEC (Figure 4, Item 2) on the Control PCB until the correct current is obtained. Press and hold the SAVE button (Figure 4-3, Item 3) for two seconds to save the setting.
4. Turn off the CCR. Remove the short from the output and apply the field load.
5. Again, turn on the CCR and set local control switch to the highest intensity step, B5 for 5-step CCR, B100 for a 3-step CCR.
6. The external True-RMS ammeter should read 6.60 ± 0.1 amps. If the reading is outside of this range, adjust the output current with buttons INC and DEC (Figure 4, Item 2) on the Control PCB until the correct current is obtained. Press and hold the SAVE button (Figure 4, Item 3) for two seconds to save the setting.

NOTE: Each CCR output current step is independently adjustable and must be independently saved.

7. Set the local switch to next to the lowest brightness step, and verify that the True-RMS ammeter reading corresponds to Table 4 and Table 5.
8. If the reading is not in the current value range given in the Tables, adjust the appropriate step until the correct current value is obtained.
9. Repeat Step 2 for the remaining lower brightness step(s).
When the output current adjustment has been completed, turn off the CCR.

4.4.2.1 Adjusting Overcurrent Control Board (44A6546)

ADJUSTING THE CCR OVER CURRENT DETECTION LEVEL

Before adjusting the Over Current Detection level, set up the regulator and adjust the output current per the **ADJUSTING THE CCR OUTPUT CURRENT** section of this section.

NOTE: The Over Current setting is pre-set and should normally not need adjusted.

To adjust the overcurrent, perform the following procedure:

1. Short the output of the CCR so the field load cannot be damaged by an over current situation during the adjustment.
2. Turn the local switch to the highest brightness step, B5 for 5-step CCR, B100 for a 3-step CCR. The true-RMS ammeter should read 6.6 amps.
3. Press and hold for three seconds both the INC and DEC buttons (Figure 4, Item 2).
The LED next to the SAVE button (Figure 4, Item 3) will light when you are in the Over Current Adjustment Mode.

NOTE: The CCR output current will increase to the level previously set as the Over Current level. This will be above 6.6 amps.

4. Press the INC or DEC buttons (Figure 4, Item 2) until you reach the desired Over Current detection level.
5. Press and hold the SAVE button for two seconds. The SAVE LED will go out and the CCR output will go back to the top step setting of 6.6 amps.
6. Remove the short from the CCR output and apply the field load.

4.4.3 Reducing CCR Power Consumption

To reduce the CCR power consumption the transformer output can be adjusted in 10 per cent increments to match applied loads. The power consumption will approximately drop with respect to the output percentage selected. See the following table and diagram to reduce the CCR power consumption.

Percent of Transformer Rated Load	Connect HV (6.6A) Output Across Terminals
10	5 and 6
20	3 and 4
30	1 and 2
40	3 and 6
50	2 and 4
60	2 and 5
70	2 and 6
80	1 and 4
90	1 and 5
100	1 and 6

Figure 5: CCT Transformer Taps

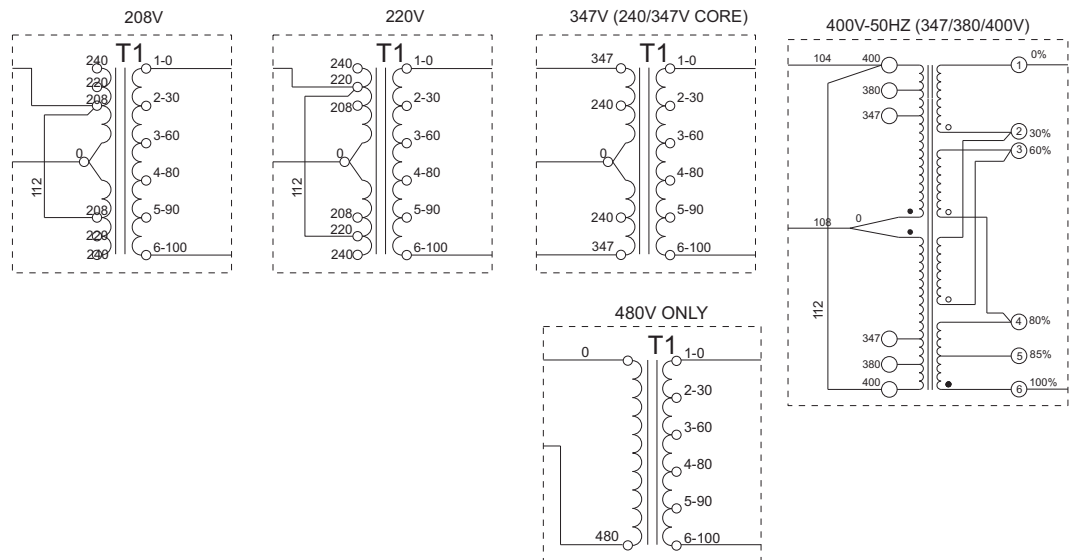

4.4.3.1 Adjusting Over Current

Before adjusting the overcurrent, set up the regulator and adjust the output current.

To adjust the overcurrent, perform the following procedure:

1. Short the output of the CCR so the field circuit cannot be damaged by an over current situation.
2. Turn the local switch to the highest brightness step, 5 for 5-step CCR or 100 for a 3-step CCR. Ammeter should read 6.6 or 20.0 amps.
3. Press and hold for three seconds both the **INC** and **DEC** push buttons (2). The LED next to the **SAVE** button (3) will light when you are in the Overcurrent Adjustment Mode.
NOTE: The CCR output current will change to the level previously set as the overcurrent level.
4. Press the **INC** or **DEC** push buttons (2) until you reach the desired Overcurrent level.
5. Press and hold the **SAVE** push button for two seconds. The SAVE LED will go out and the CCR output will go back to the top step setting (6.6 or 20A).

4.5 SCO Cutout Working Positions

See Figure 6 and Figure 7. The SCO cutout can be plugged in three orientations. For additional information on the SCO cutout, refer to manual 96A0294, *SCO Cutout*.

Figure 6: SCO Cutout Handle Orientations

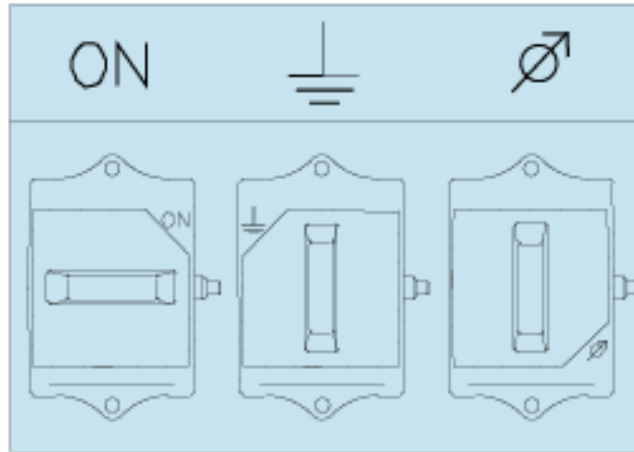

In the operation position, the regulator is connected to the series circuit, and the micro switch is activated.

NOTE: An activated micro switch means that the normally open contact is closed and that the normally closed contact is open. For interlocking with the CCR, only the normally open contact is used. When the cover is removed, the micro switch is not activated.

Figure 7: SCO Cutout Operation Position

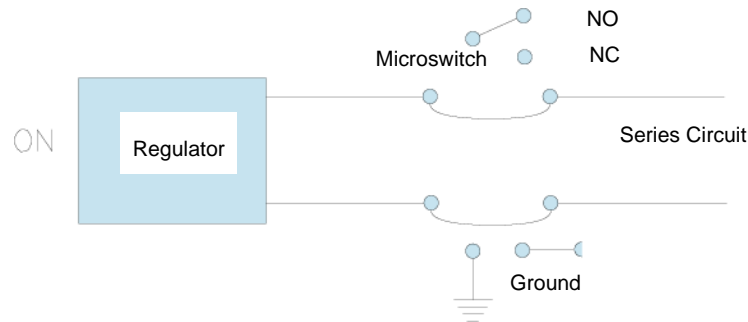

See Figure 8. In the maintenance position, the regulator and the series circuit are both shorted and grounded. The micro switch is not activated.

Figure 8: SCO Cutout Maintenance Position

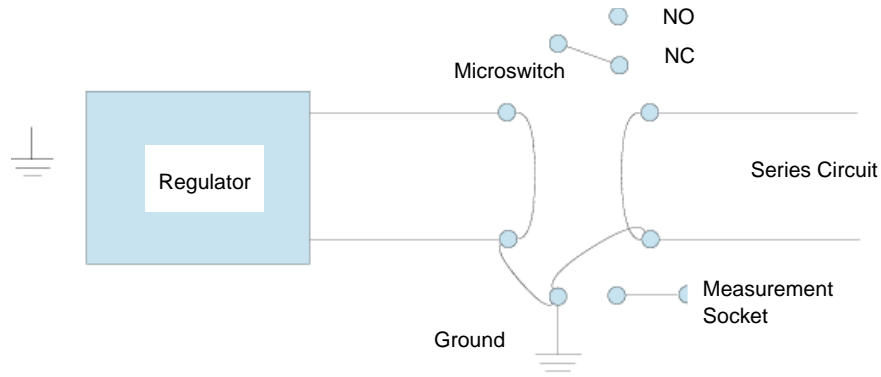

You can determine the current orientation by observing the cutoff corner of the handle.

See Figure 9. In the test and measure position, the insulation resistance of the series circuit can be measured. The regulator operation can be tested under short-circuited output conditions.

In the test and measure position, the regulator is shorted and grounded, the series circuit is shorted and connected to the measurement socket. The micro switch is activated.

Figure 9: SCO Cutout Test and Measure Position

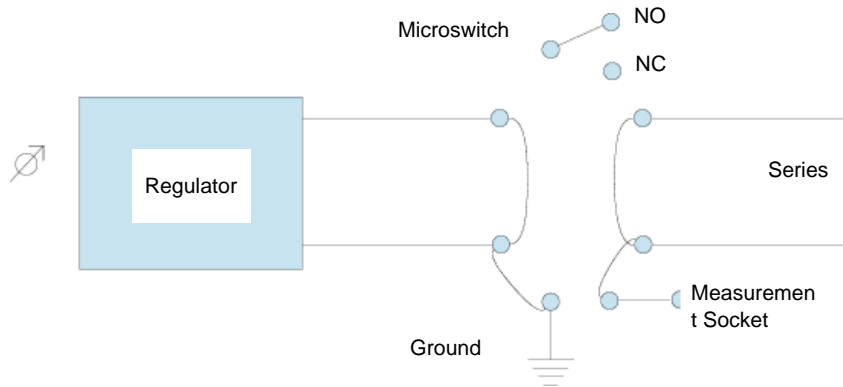

4.6 Application Notes

Monitoring Option	Description	Application
0	None	Standard L-828 supplied with analog ammeter
1	ALCMS Scanning Monitor Interface (SMI)	The SMI option adds Primary Power and Remote/Local monitoring relays. Dry relay contacts are connected to a dedicated terminal block for each monitored point. Typical application: connecting ADB L-828 CCR to ALCMS or L-827 that is manufactured by others. Note that this option does not provide dedicated output current or voltage transformers.
2	ALCMS Scanning Monitor Ready (SMR)	The SMR option adds several monitoring relays (including Primary Power and Remote/Local) and also CCR output current and voltage transformers. All monitored signals are connected to a dedicated terminal block. Application only for connecting ADB L-828 CCR to ADB Gen I/II ALCMS scanning monitoring system.
3	L-829 Monitoring (ACE™)	Includes FAA L-829 monitoring equipment. <ul style="list-style-type: none"> • If application is for connection to ADB L-890 ALCMS: Add a "/A" to end of Ordering Code. The ACE unit will then be programmed to provide monitoring data via dual-redundant communication links. • If application is for a stand-alone L-829 CCR: Ordering Code is not changed. The ACE unit is programmed to activate a dry contact closure if a fault is present. The fault alarm can then be connected to any external monitoring system.
4	Insulation Resistance Monitoring System (IRMS) Ready	This option adds an IRMS board in the CCR. Application: connection to externally mounted ADB ACE unit.
5	L-829 Monitoring (ACE) and IRMS	Includes FAA L-829 and IRMS equipment. <ul style="list-style-type: none"> • If application is for connection to ADB L-890 ALCMS: Add a "/A" to end of Ordering Code. The ACE unit will then be programmed to provide monitoring data via dual-redundant communication links. • If application is for a stand-alone L-829 CCR with Insulation Resistance Monitoring: Ordering Code is not changed. The ACE unit is programmed to activate a dry contact closure if a fault is present. The fault alarm can then be connected to any external monitoring system.
6	L-828 with Digital Power Meter	This option replaces the analog ammeter with a Digital Power Meter. The Digital Power Meter is used on L-828 CCRs to indicate True RMS output current, voltage, VA, and watts. It can also be set to activate an alarm if there is a 10% or 15% drop in the load (Low VA).

4.7 Digital Power Meter Calibration

Figure 10: Digital Power Meter



4.7.1 Function Buttons

Figure 11: Function Buttons

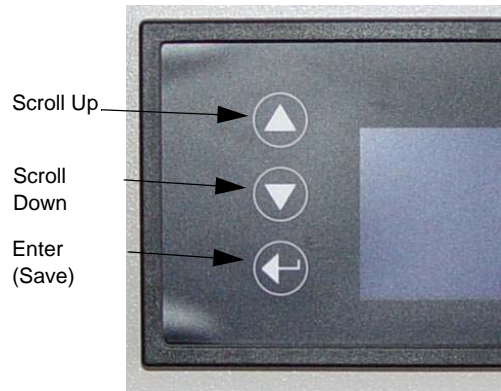

4.7.1.1 Displays

Figure 12: Displays



NOTE: Scroll through displays using the **Scroll Up** and **Scroll Down** buttons. After 30 seconds the display will revert to the default setting of **Arms**.

4.7.2 Calibration

NOTE: The following is needed to calibrate the DPM:

- Calibrated True RMS AC current clamp.
- High Voltage probe capable of reading 5,000Vrms.
- Ability to apply a shorted load to CCR.
- Ability to apply a field load or equivalent resistive load to CCR.



WARNING

The CCR must be operating during calibration. Risk of electrical shock. Failure to observe this warning may result in personal injury, death, or equipment damage.

Proceed as follows to calibrate the DPM

1. Depress and hold the top **SCROLL** button and the bottom **ENTER** button **simultaneously** for 3 seconds (See Function Buttons in Figure 11) to enter the calibration menu.

Figure 13: DPM Calibration Menu

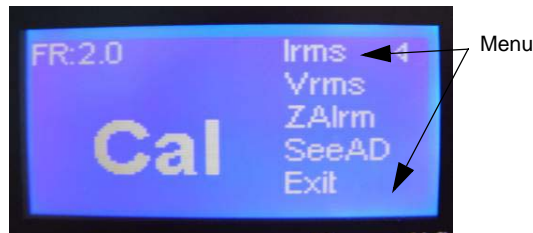

The **SCROLL** Buttons are used to select items on the calibration menu. Scroll to the desired selection and then press the **ENTER** button. See the following steps to calibrate the DPM.

2. Current Calibration

During calibration you will be asked to wait until displayed "cnt" values settle. These "cnt" values are internal A/D values as measured by the power meter's microprocessor. These values will always vary slightly while the meter is measuring voltage and current. They are displayed to give feedback that the load has settled and the meter is obtaining a steady reading.

NOTE: At each calibration step, wait until the thousands digit has settled before proceeding.

a. Irms – High Step (6.6 amps)

Using the **SCROLL** buttons, select Irms and follow the prompts to calibrate the Irms.

- Short the CCR output and then turn the CCR to the highest step.
- Measure the CCR output current with a True RMS current meter and adjust the current value on the meter display to match.

NOTE: If the CCR output needs to be adjusted follow procedure in the CCR manual.

- Wait until the Icnt and Vcnt values settle and select the **ENTER** button

Figure 14: Irms – High Step Calibration



b. Irms Low Step (2.8 amps)

Repeat the previous steps and follow the prompts for the Low CCR step. Press **ENTER** button to save.

Figure 15: Irms – Low Step Calibration



3. Voltage Calibration

At the calibration screen, scroll to Vrms on the menu and press the **ENTER** button. The next screen (Figure 16) shows the last calibration voltage set points and internal A/D numbers. **Select Y** (yes) to enter the Vrms calibration.

Figure 16: Vrms Calibration

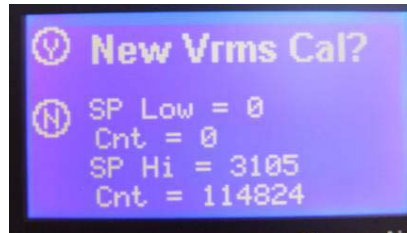

a. Vrms – High Step Loaded

Following screen prompts, apply the field load or equivalent resistive load to the CCR at the high step. Measure the Vrms at the CCR output with the High Voltage probe. Adjust the meter display to match the measured voltage. Wait for the CNT number to settle (this may take a couple minutes while the load heats up) and then press the ENTER button.

Figure 17: Vrms Hi-Step Loaded

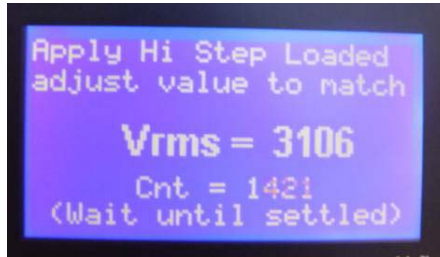

b. Vrms - Off

Follow the prompts to turn off the CCR, When the CNT has settled press ENTER button. (CNT may not go to zero)

Figure 18: Save Vrms Calibration

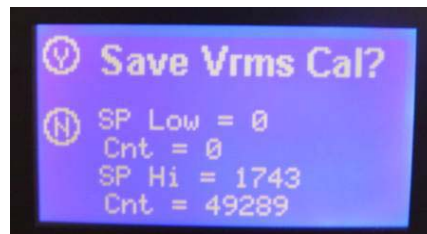

5.0 CCT Maintenance

WARNING



Only personnel authorized to work on high-voltage equipment should perform maintenance on the regulator.

- Operate regulator under local control (using rotary switch) when performing maintenance tasks on the regulator. This will prevent the regulator from accidentally being turned on and causing serious injury or death. De-energize regulator by turning rotary switch to OFF, and remove input power to regulator by turning off disconnect switch or main circuit breaker before opening access door to service regulator.
- If the regulator experiences an overvoltage or an overcurrent fault, it will enter protective shutdown mode. In this mode, the regulator turns off until either power to the regulator is cycled, or the regulator is turned off with either the rotary switch or the remote controls.

5.1 Introduction to Maintenance

This section provides preventive maintenance for L-828/L-829 CCT constant current regulators (CCRs) (4-30 kW).

5.2 Maintenance Schedule

To keep the L-828/L-829 CCRs operating efficiently, follow a preventive maintenance schedule. Refer to Table 1.

Table 1: L-828/L-829 CCR (4-30 kW) Maintenance

Interval	Maintenance Task	Action
Daily	Check all control equipment for proper operation.	Check local and remote control (if used) on each brightness step.
Monthly	Check input voltage.	If input voltage is not within -5% to +10% of the nominal value specified on the nameplate of the regulator, notify power company to correct voltage.
	Check and record output current on each brightness step.	Use a true rms-reading instrument. Adjust current levels if out of tolerance. Refer to <i>Adjustment Procedures</i> in the <i>Operation</i> section. Refer to Table 8 for the current range for the 3-Step and 5-Step CCRs.
Annually	Check relays, wiring and insulation.	Clean dirty or slightly pitted contactor contacts. Use a fine file for surface cleaning. Replace contacts that are excessively burned or pitted.
		Operate the local control switch to check for proper operation of relays and contactors.
		Make sure input and output connections are tight and that no damaged wires or damaged insulation exists.
	Inspect housing for rust spots.	Clean and touch-up rust spots with paint.
	Inspect lightning arrestor connections.	Tighten any loose connections. Replace charred or burnt wiring or broken arrestors.
	Perform a short-circuit test.	Refer to <i>Short-Circuit Test</i> in this section.
Perform an open-circuit test.	Refer to <i>Open-Circuit Test</i> in this section.	
Unscheduled	Check load on regulator.	At installation and subsequent load changes make sure that the output RMS voltage times the output true RMS current does not exceed the rated load on the nameplate of the regulator.

5.2.1 Short-Circuit Test



WARNING

Since high open-circuit voltages may result by opening the primary of a series lighting circuit, only personnel authorized to work on high-voltage equipment should be allowed to perform the short-circuit test.

To perform the short-circuit test, perform the following procedure:

- Remove input power to the regulator (turn off disconnect switch or main circuit breaker) and turn the rotary switch to OFF.
- Remove leads from output terminals and bushings. Use AWG 8 or larger wire to short output bushings.
- Energize the regulator and turn the rotary selector switch to the lowest brightness step (B1 or B30) and then to the remaining brightness steps. Check the output current on the ammeter at each step.

NOTE: The output current should be within the tolerance given in Table 8. The panel meter is intended to indicate function. Any calibrations should be performed with a calibrated true RMS current meter.

If the output current is not within the limits specified in Table 8 check the input voltage to the regulator. The supply voltage should be within -5% to $+10\%$ of the nominal input voltage given on the regulator nameplate. Refer to *Adjustment Procedures* in the *Operation* section.

- Turn off disconnect switch or main circuit breaker to remove input power to regulator.
- Disconnect the shorting jumper and reconnect output cables.
- Close input-power disconnect switch or main circuit breaker.

5.2.2 Open-Circuit Test



WARNING

Since high open-circuit voltages may result by opening the primary of a series lighting circuit, only personnel authorized to work on high-voltage equipment should be allowed to perform the open-circuit test.

To perform the open-circuit test, perform the following procedure:

- Remove input power to regulator (turn off disconnect switch or main circuit breaker) and turn the rotary switch to OFF.
- Disconnect cables from the output terminals and bushings.
- Turn on input power to the regulator.
- Turn the rotary switch to the lowest brightness position (B1 or B30). The open-circuit protective device should automatically de-energize the regulator in less than 2 seconds.
- Turn the rotary switch to OFF. The open-circuit protective device should reset.
- Turn the rotary switch to position B1 or B30. The regulator should turn on and then de-energize in less than 2 seconds.
- If regulator operation is satisfactory, turn rotary switch to OFF, and turn off disconnect switch or main circuit breaker before reconnecting the load.
- After the load has been reconnected, turn on input power to the regulator.

5.3 Troubleshooting



WARNING

Allow only qualified personnel to perform the following tasks. Observe and follow the safety instructions in this document and all other related documentation.

- De-energize regulator by turning rotary switch S1 to OFF, and remove input power to regulator by turning off disconnect switch or main circuit breaker. Discharge capacitors and ground output terminals bushings by using a grounding rod prior to touching any parts.
- If the regulator de-energizes, the output circuit could be interrupted by an overcurrent, open-circuit, or under-voltage condition. Before inspecting the output circuit, place rotary selector switch S1 in the OFF position and turn off disconnect switch or main circuit breaker. Without this precaution, a dip in the power line may reset the regulator and turn it on, resulting in an output voltage of thousands of volts which can cause serious injury or death.
- Contents are static-sensitive. Must be grounded when handling PCB.



CAUTION

Short the output terminals before switching the regulator on. The wire should be AWG 8 or larger.

5.4 Introduction

This section provides a preliminary troubleshooting check list and troubleshooting procedures for the CCT L-828/L-829 CCR (4-30 kW):

5.5 Preliminary Troubleshooting

The following is a check list of initial steps to perform.

- Visually examine all areas of the CCR. Do burnt or loose connections/parts exist?
- Is the input voltage present and within -5 to +10% of nominal?
- Check all the fuses.
- Are the wire harness connectors to the control board fully seated?
- Have the PCBs been adjusted in accordance with the instruction manual?
- If the CCR works in local but not Remote, check the voltage on the Remote control lines.
- Can the CCR be re-energized by turning the rotary switch from OFF to Step B1 (B10)?
- Short the output of the CCR with an AWG 8 wire, and turn on the CCR. If the regulator operates normally, the problem is probably load related.
- If the CCR turns on and then shuts off after a few seconds and the ammeter has a high current reading, the problem is overcurrent. Adjust the output current accordingly. If the output current is not adjustable, replace the control board restart the regulator.
- If the CCR still fails in overcurrent, replace the SCR and restart.

5.6 Troubleshooting

This subsection provides information for troubleshooting fuses and other components.

5.6.1 L-828/L-829 Input Power Fuses F1 and F2.

Amp rating as a function of input voltage and CCR kW rating for input power fuses F1 and F2 on the L-828 and L-829 CCRs. Input Power Fuses, F1 and F2, per CCR Input Voltage and CCR kW Rating

Table 2: CCT/XXXX INPUT FUSES (F1, F2)

SIZE	208 Volts	220 Volts	240 Volts	347 Volts	380/400 Volts	480 Volts
4kW	47A0092	47A0069	47A0069	47A0191	47A0191	47A0090
7.5kW	47A0093	47A0093	47A0070	47A0193	47A0193	47A0091
10kW	47A0094	47A0071	47A0071	47A0088	47A0086	47A0085
15kW	47A0099	47A0096	47A0096	47A0217	47A0087	47A0088
20kW	47A0072	47A0072	47A0099	47A0097	47A0217	47A0087
30kW	47A0102	47A0101	47A0101	47A0106	47A0217	47A0097
47A0069	Fuse 25A 250V Time Delay					
47A0070	Fuse 45A 250V					
47A0071	Fuse 60A 250V					
47A0072	Fuse 125A 250V					
47A0085	Fuse 30A 600V					
47A0087	Fuse 60A 600V					
47A0088	Fuse 50A 600V					
47A0090	Fuse 12A 600V					
47A0091	Fuse 25A 600V					
47A0092	Fuse 30A 250V					
47A0093	Fuse 50A 250V					
47A0094	Fuse 70A 250V					
47A0096	Fuse 80A 250V					
47A0097	Fuse 90A 600V					
47A0099	Fuse 110A 250V					
47A0101	Fuse 175A 250V					
47A0102	Fuse 200A 250V					
47A0106	Fuse 125A 250V					
47A0191	Fuse 20A 600V					
47A0193	Fuse 35A 600V					
47A0217	Fuse 80A 600V					

Table 3: CCT/XXXX T3 Fuses (F3, F4)

SIZE	208 Volts	220 Volts	240 Volts	347 Volts	380/400 Volts	480 Volts
4kW	47A0113	47A0113	47A0113	47A0113	47A0113	47A0108
7.5kW	47A0113	47A0113	47A0113	47A0187	47A0187	47A0108
10kW	47A0113	47A0113	47A0113	47A0113	47A0113	47A0108
15kW	47A0187	47A0187	47A0187	47A0187	47A0187	47A0187
20kW	47A0187	47A0187	47A0187	47A0187	47A0187	47A0187
30kW	47A0187	47A0187	47A0187	47A0187	47A0187	47A0187

47A0187	Fuse 3A 500V
47A0108	Fuse 1A 500V
47A0113	Fuse 2A 250V
49A0084	Fuse Holder (Double) (4, 20-30 kW)

Table 4: CCT/XXXX ACE Fuses F5, F6

47A0119	Fuse .5A 250V
47A0061	Fuse Block (Single)

Table 5: CCT/XXXX Input Fuse Blocks

SIZE	208 Volts	220 Volts	240 Volts	347 Volts	380/400 Volts	480 Volts
4kW	72A0091	72A0091	72A0091	49A0081	49A0081	49A0081
7.5kW	72A0098	72A0091	72A0098	49A0082	49A0082	49A0081
10kW	72A0091	72A0098	72A0098	49A0082	49A0082	49A0081
15kW	72A0099	49A0091	49A0091	49A0085	49A0082	49A0082
20kW	72A0099	72A0099	72A0099	49A0085	49A0085	49A0082
30kW	72A0099	72A0099	72A0099	49A0085	49A0085	49A0085

49A0081	Fuse Block, 10-30A, 600V
49A0082	Fuse Block, 31-60A, 600V
49A0085	Fuse Block, 61-100A, 600V
49A0091	Fuse Block, 61-100A, 250V
49A0097	Fuse Block, 100-200A, 250V
72A0091	Fuse Block, 2P, 30A, 250V
72A0098	Fuse Block, 31-60A, 250V
72A0099	Fuse Block, 100-200A, 250V

Table 6: CCT/XXXX CONTACTORS (K2)

SIZE	208 - 240 Volts	347 Volts	380/400 Volts	480 Volts
4kW	53A0412/25	53A0412/25	53A0412/25	53A0412/25
7.5kW	53A0412/50	53A0412/40	53A0412/40	53A0412/40
10kW	53A0412/60	53A0412/50	53A0412/40	53A0412/40
15kW	53A0412/90	53A0412/75	53A0412/50	53A0412/40
20kW	53A0412/120	53A0412/90	53A0412/75	53A0412/50
30kW	53A0331	53A0412/150	53A0412/75	53A0412/75

53A0331	Contactors 3P 200A 170A 120VAC Coil
53A0412/25	Contactors 2P 25 FLA
53A0412/40	Contactors 2P 40 FLA
53A0412/50	Contactors 2P 50 FLA
53A0412/60	Contactors 2P 60 FLA
53A0412/75	Contactors 2P 75 FLA
53A0412/90	Contactors 2P 90 FLA
53A0412/120	Contactors 2P 120 FLA
53A0412/150	Contactors 2P 150 FLA

Table 7: CCT/XXXX Dual SCR Block (SCR)

SIZE	208 - 480 Volts
4kW	28A0045
7.5kW	28A0039
10kW	28A0038
15kW	28A0034
20kW	28A0041
30kW	28A0041
28A0034	Dual SCR Module (15 kW)
28A0038	Dual SCR Module (10 kW)
28A0039	Dual SCR Module (7.5 kW)
28A0041	Dual SCR Module (20-30 kW)
28A0045	Dual SCR Module (4kW)

Table 8: CCT/XXXX Current Transformer T2 (and T3 for 20A)

SIZE	T2 6.6A and 20A	T3 20A
4kW	35A0290	N/A
7.5kW	35A0290	N/A
10kW	35A0290	N/A
15kW	35A0290	35A0308
20kW	35A0290	35A0308
30kW	35A0290	35A0308
35A0290	Current Transformer 6.6/6.6A (Only required if analog current meter used)	

Table 9: CCT/XXXX Power Transformer T1 (Core)

SIZE	208V 6.6A	220V 6.6A	240V 6.6A	347V 6.6A	380/400V 6.6A	480V 6.6A
4kW	35B0462 35A0696 ¹	35B0462 35A0696 ¹	35B0462 35A0696 ¹	35A0579	35A0753	35B4462/480
7.5kW	35B0463 35A0697 ¹	35B0463 35A0697 ¹	35B0463 35A0697 ¹	35A0580	35A0752	35B0463/480
10kW	35B0464 35A0698 ¹	35B0464 35A0698 ¹	35B0464 35A0698 ¹	35A0581	35A0748	35B0464/480
15kW	35B0465 35A0699 ¹	35B0465 35A0699 ¹	35B0465 35A0699 ¹	35A0749	35A0749	35B0465/480
20kW	35A0614/1 35A0700 ¹	35A0614/1 35A0700 ¹	35A0614/1 35A0700 ¹	35A0614/5	35A0750	35A0614/2
30kW	35A0613/1 35A0701 ¹	35A0613/1 35A0701 ¹	35A0613/1 35A0701 ¹	---	35A0613/5	35A0613/2

Table 10: Power Core List

Part Number	Power Core Description
35A0579	4kW CCT Power Transformer, 347V, 6.6A
35A0580	7.5kW CCT Power Transformer, 347V, 6.6A
35A0581	10kW CCT Power Transformer, 347V, 6.6A
35A0613/1	30kW CCT Power Transformer, 208/220/240V, 6.6A
35A0613/2	30kW CCT Power Transformer, 480V, 6.6A
35A0613/5	30kW CCT Power Transformer, 380/400V, 6.6A 50/60 Hz
35A0614/1	20kW CCT Power Transformer, 208/220/240V, 6.6A
35A0614/2	20kW CCT Power Transformer, 480V, 6.6A
35A0614/5	20kW CCT Power Transformer, 347V, 6.6A
35A0696	4kW CCT Power Transformer, 208/220/240V, 6.6A 50Hz
35A0697	7.5kW CCT Power Transformer, 208/220/240V, 6.6A 50Hz
35A0698	10kW CCT Power Transformer, 208/220/240V, 6.6A 50Hz
35A0699	15kW CCT Power Transformer, 208/220/240V, 6.6A 50Hz
35A0700	20kW CCT Power Transformer, 208/220/240V, 6.6A 50Hz
35A0701	30kW CCT Power Transformer, 208/220/240V, 6.6A 50Hz

**CCT (Thyristor Controlled) L-828/L-829 Constant Current Regulator
Troubleshooting**

Part Number	Power Core Description
35A0748	10kW CCT Power Transformer, 380/400V, 6.6A 50/60 Hz
35A0749	15kW CCT Power Transformer, 347/400V, 6.6A
35A0750	20kW CCT Power Transformer, 380/400V, 6.6A 50/60 Hz
35A0752	7.5kW CCT Power Transformer, 380/400V, 6.6A 50/60 Hz
35A0753	4kW CCT Power Transformer, 380/400V, 6.6A 50/60 Hz
35B0462	4kW CCT Power Transformer, 208/220/240V, 6.6A
35B0463	7.5kW CCT Power Transformer, 208/220/240V, 6.6A
35B0463/480	7.5kW CCT Power Transformer, 480V, 6.6A
35B0464	10kW CCT Power Transformer, 208/220/240V, 6.6A
35B0464/480	10kW CCT Power Transformer, 480V, 6.6A
35B0465	15kW CCT Power Transformer, 208/220/240V, 6.6A
35B0465/480	15kW CCT Power Transformer, 480V, 6.6A
35B4462/480	4kW CCT Power Transformer, 480V, 6.6A

Table 11: CCT/XXXX Choke (4-15kW Only)

33A0013	4kW Choke
33A0015	7.5kW Choke
33A0016	10kW Choke
33A0019	15kW Choke

Table 12: CCT/XXXX Input Lightning Arrestor

32A0028	Input Power Lightning Arrestor (All sizes and input voltages 208 - 480) (Kit used is 94B0011)
---------	--

Table 13: CCT/XXXX Output Lightning Arrestor

32A0025	Output Surge Arrestor, 4-10kW, Use Kit 94A0576
32A0114	Output Surge Arrestor, 15-30kW (6.6A)

Table 14: CCT/XXXX Current Sensing Transformer (T5)

SIZE		
6.6A	35A0548	Transformer, Current Sensing, 6.6A to 66mA

Table 15: CCT/XXXX Power Transformer (T4)

35A0438	240/347/380/400/480 to 120/24 .5A (4, 7.5, 10, 15 kW)
35A0439	240/347/380/400/480 to 120/24 .5A (20, 30 kW)

Table 16: CCT/XXXX Other parts

44A6546	Control PCB, 60Hz
44A6397	IRMS-LI Board (Option)
44D1476/1	3-step Switch PCB
44D1476/2	5-step Switch PCB
44A6528	Digital Power Meter (Option)
1475.92.030	SCO Series Circuit Cutout (Option)
33A0055	Ferrite Core
70A0624	Fiber Optic Cable (M-M) (Grey) (optional)
70A0625	Fiber Optic Cable (M-M) (Blue) (optional)

Table 17: CCT/XXXX Circuit Voltage Monitor Assembly (CVM) (Option)

44A6326/10	Circuit Voltage Monitor Assembly (6.6A)
------------	---

Table 18: CCT/XXXX Ammeter

52A0107	Analog Ammeter (6.6A)
---------	-----------------------

NOTE: Refer to ACE Manuals for Optional L-829 Monitoring and Control.

5.6.2 L-828 General Troubleshooting

This subsection provides general troubleshooting procedures for the L-828 CCR.



WARNING

Read the instructions in their entirety before starting installation.
 Only personnel authorized to work on high-voltage equipment should perform maintenance on the regulator.
 Since high open-circuit voltages may result by opening the primary of a series lighting circuit, only personnel authorized to work on high-voltage equipment should be allowed to perform the open-circuit test.
 Operating a regulator for long periods of time while seriously overloaded may cause the regulator to overheat.

Table 19: General Troubleshooting

Problem	Possible Cause	Corrective Action
1. Regulator not turning on	Main power supply off	Verify presence of input voltage.
	Switched off due to overcurrent	Switch regulator off in local. Wait for 2 seconds and check to see if the regulator now operates correctly.
	Incorrect external wiring	If the regulator works correctly in local but not in Remote, check the Remote control signals.
	Blown fuse	Replace any blown fuse. Check the input supply voltage and make sure that it is between -5% and +10% of the nominal value listed on the CCR nameplate.
	Defective PCB	Replace PCB.
2. Regulator turns on but de-energizes suddenly	Output circuit interrupted	Apply a short to the regulator output. Turn the regulator on. If the regulator works correctly, repair the lighting circuit. Follow all safety precautions in this manual.
	Defective printed circuit board	Replace regulator controller.
	Overcurrent condition	Verify that SCR is triggering by replacing the PCB. Check SCRs and wiring. Replace SCR.
3. Output Current always 6.6 A	CCT regulator controller not calibrated	Refer to "Output Current Adjustment" on page 29 Check remaining steps to verify the values from Table 8.
	Overcurrent condition	Refer to problem #2 in this table, <i>Regulator turns on but de-energizes suddenly.</i>
4. Output Current always 4.8 A or less for 3-Step CCR or 2.8 A or less for 5-Step CCR	Defective control board	If problem exists in Remote and local control, replace CCT regulator controller.
	SCRs always conducting	Verify SCR is triggering by replacing PCB. Check SCRs and wiring for shorts in SCR circuitry. Replace SCR.
	CCR overload	Remove section of load.
5. More than 2 seconds required for CCR to de-energize on open-circuit load	Faulty overcurrent protection	Replace CCT Regulator Controller PCB.
6. Short lamp life and/or high output current reading on panel ammeter	Incorrect output current adjustment	Refer to "Output Current Adjustment" on page 29.
	Faulty overcurrent protection	Replace CCT Regulator Controller PCB.

Problem	Possible Cause	Corrective Action
7. Regulator not indicating proper current	Incorrect output current adjustment	Refer to "Output Current Adjustment" on page 29. Refer to Problem #10 in this table.
	Current meter not calibrated or faulty	Turn the regulator to the top step (6.6 A/20 A). Verify the current with a true-rms current meter. If the meter is not accurate, adjust the meter with the screw on the front cover. For systems equipped with ACE, refer to: <ul style="list-style-type: none"> Advanced Control Equipment (ACE1) manual 96A0287 or Advanced Control Equipment (ACE2) manual 96A0357 for display calibration procedures.
8. Regulator operates by the local control switch but not by Remote control	The rotary switch on the input module not set to REM	Set the rotary switch to REM.
	Blown fuse	Check fuse F5.
	Loose or broken Remote control wires	Check connections on Remote terminal block TB1. If 120 Vac Remote control signals are used, use an AC voltmeter (300 Vac scale) to verify correct signals are received at the CCR.
	Incorrect wire connections	Refer to Table 1 through Table 2.
9. Ammeter on CCR oscillates and loud noise occurs	SCR drive not working properly	Check connections at SCR module. Replace CCT Regulator Control PCB. Verify that the CCR transformer output taps are not set too low for the desired output. Refer to Table 1 through Table 3.
10. Output current not able to be adjusted up to 6.6 A/20 A	Regulator load too large	Either reduce the load or replace the regulator with a larger kW CCR. When overloaded, the regulator may make a faint bouncing sound as the controller bounces against the upper control limits. NOTE: This problem can also be verified by shorting the output of the CCR and verifying output current can be adjusted correctly in each step.

5.7 Additional L-829 General Troubleshooting Procedures

For additional L-829 CCR general troubleshooting procedures, refer to the *Troubleshooting* section in manuals:

- 96A0287, Advanced Control Equipment (ACE™) or
- 96A0357, Advanced Control Equipment (ACE2™).

5.8 Component Replacement Procedures

Replacement procedures for several various components.

5.8.1 Removing and Replacing CCT Regulator Control PCB

1. Turn CCR local switch to the OFF position.

Figure 1: CCT Regulator Control PCB (44D1475)

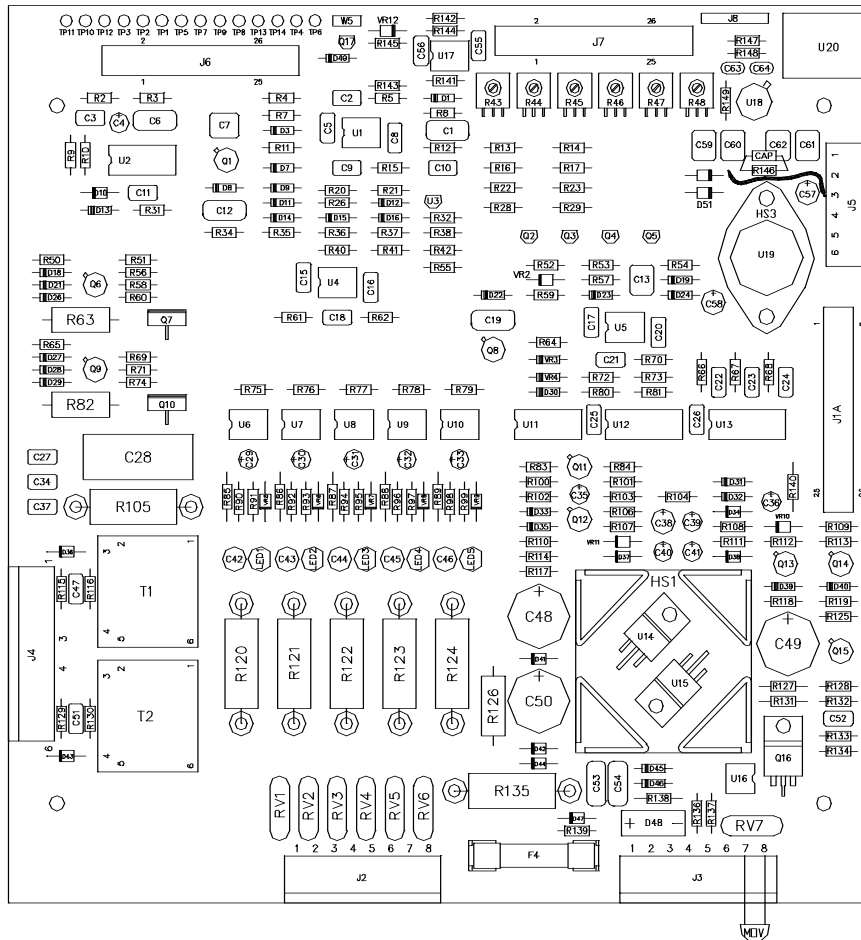

2. Remove and lock out/tag out primary power to the CCR at the breaker panel.
3. Lock out/tag out the SCO in the maintenance position.
4. Loosen the door latch screws and open the CCR door.
5. Unplug green connectors J8, J1, J2, J3, J4, and J5 from the PCB.
6. Disconnect the ribbon cable from J6 by pressing out on the tabs at both sides of the ribbon connection and pull the cable away from the board.
7. Remove the 4 screws at the 4 corners of the PCB. Remove the ground wire from the top right corner. Remove and label the ground wire from the top left corner of the PCB.

Figure 2: Regulator Control PCB (44A6546)

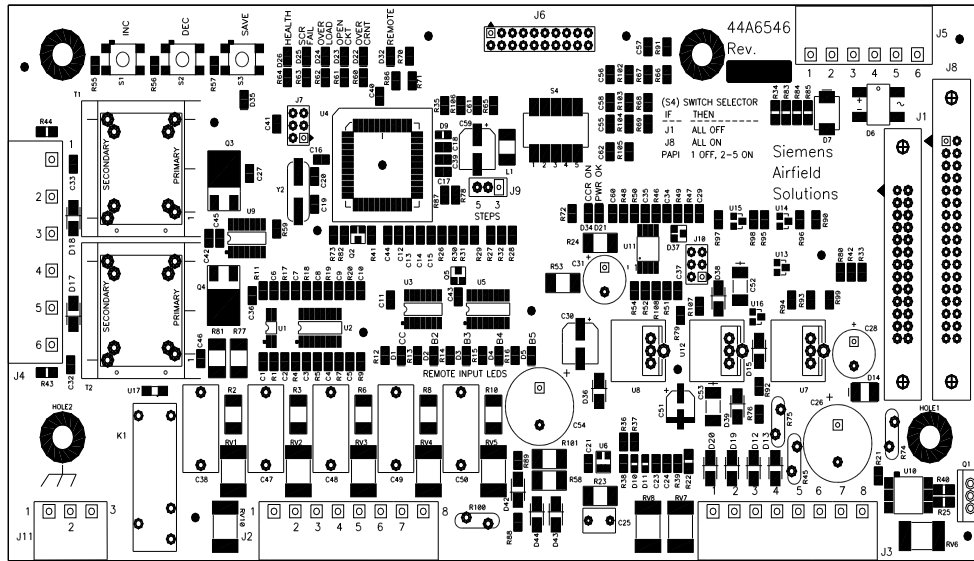

8. Mount the new PCB by replacing the 4 screws at the corners of the PCB including the ground wire on the top right corner.
9. Plug the ribbon cable back into J6 by pressing it in. It is keyed and will only go in one way. Also verify the tabs on the side have locked into place.
10. Plug in all of the green connectors to the board. J8, J1, J2, J3, J4, and J5. (**NOTE:** this procedure is valid for both the old and new boards which have the same J connectors)
11. Close the CCR door and tighten the door latch screws.
12. Restore the SCO to the ON position.
13. Restore primary power to the CCR at the breaker panel.
14. Turn the CCR local switch to the REM position.

5.8.2 Removing and Replacing Dual SCR Module Assembly

See drawing 43A2845

Figure 3: Dual SCR Module Assembly

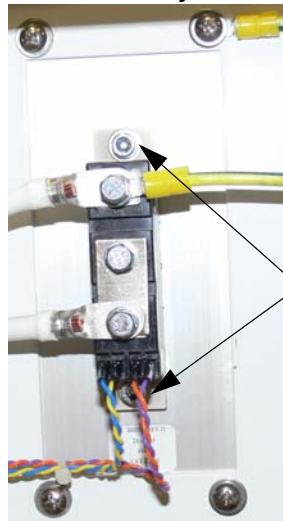

#10 Split Lock Washer (2 or 4 each)
and
¼-20 X 1/2 Hex Head Screw (2 or 4 each)

1. Turn CCR local switch to the OFF position.
2. Remove and lock out/tag out primary power to the CCR at the breaker panel.
3. Lock out/tag out the SCO in the maintenance position.
4. Open the CCR front door by loosening the 3 door screws.
5. Remove wire 105 and the ground wire from the top lug of the SCR using a 11/16-inch socket.
NOTE: * There are different versions of this SCR so hardware may vary.
6. Remove wire 107 from the bottom lug of the SCR using a 11/16-inch socket.
7. Pull the 4 colored gate wires from the bottom of the SCR.
8. Remove the SCR from the regulator by removing the (2) 5/32-hex mounting screws. Clean the heat-sink surface with a dry rag.
9. The replacement SCR will arrive mounted to a rectangular metal plate.
10. Remove the SCR from the attached plate by removing the (2) 5/32-hex mounting screws from the new SCR and the mounting it to the existing plate in the front of the regulator. Place a thin layer of thermal paste on the heat-sink prior to attaching the SCR.
11. Once the SCR is mounted in the CCR, connect wire 105 and the ground wire to the top lug of the SCR.
12. Connect wire 107 to the bottom lug of the SCR.
13. Connect the colored gate wires according to the documentation supplied with the replacement SCR. Different versions of the SCR require these gate wires to be connected in a different order, refer to the documentation shipped with the replacement SCR.
14. Close all doors and replace all panels.
15. Restore the SCO to the ON position.
16. Restore primary power to the CCR at the breaker panel.
17. Turn the CCR local switch to the REM position.

5.8.3 Removing and Replacing Contactor

1. Turn CCR local switch to the OFF position.

Figure 4: CCR Power Contactor

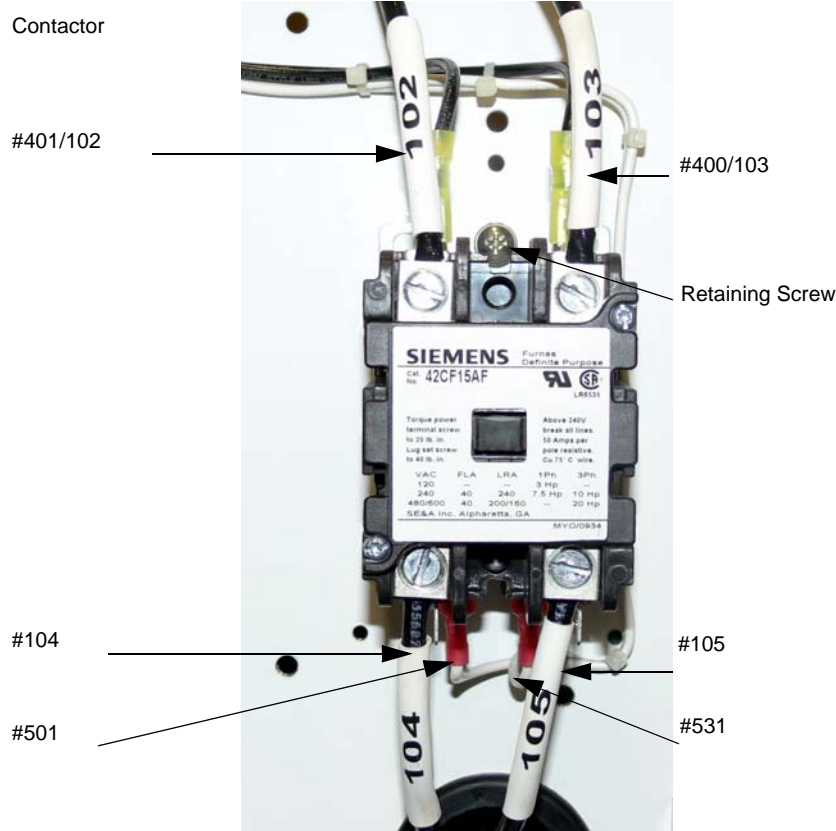

2. Label the wires.
3. Remove and lock out/tag out primary power to the CCR at the breaker panel.
4. Lock out/tag out the SCO in the maintenance position.
5. Open the CCR front door by loosening the 3 door screws.
6. Loosen the wire retaining lugs for 102, 103, 104 and 105 and disconnect. See Figure 1 and Figure 3 in the “Schematics” on page 59.
7. Label any wires not labeled prior to disconnecting them.
8. Remove wires 400 and 401 from the top connectors of the contactor.
9. Remove the wires 531 and 501 from the contactor coil connections at the bottom of the contactor.
10. Remove the 3 mounting screws until the contactor is free.
11. Replace the contactor. Tighten the contactor retaining screws on the contactor plate.
12. Connect wires 531 and 501 to the contactor coil connections at the bottom of the contactor.
13. Connect wires 400 and 401 to the top connectors of the contactor.
14. Connect the wires for 102, 103, 104 and 105 and tighten retaining lugs.
15. Close the CCR front door by tightening the 3 door screws.
16. Restore the SCO to the ON position.
17. Restore primary power to the CCR at the breaker panel.
18. Turn the CCR local switch to the REM position.

5.8.4 Removing and Replacing Input Lightning Arrestors (front of Component Mounting Plate)

1. Turn CCR local switch to the OFF position.
2. Remove and lock out/tag out primary power to the CCR at the breaker panel.
3. Lock out/tag out the SCO in the maintenance position.

4. Open the CCR front door by loosening the 3 door screws.
5. Loosen the wire retaining screws for 402, 403, 802 and 803 and disconnect. See drawing 43A2845.
6. Remove the top two of (4) #10 x 32 pan-head screws and loosen the bottom two screws until the arrestors are free.
7. Replace the Input Lightning Arrestor assembly. Replace the two top screws on the assembly plate and tighten all four until the arrestors are secure.
8. Connect the wires for 402, 403, 802 and 803 and tighten retaining screws.
9. Close the CCR front door by tightening the 3 door screws.
10. Restore the SCO to the ON position.
11. Restore primary power to the CCR at the breaker panel.
12. Turn the CCR local switch to the REM position.

5.8.5 Removing and Replacing Output Lightning Arrestors (front of Component Mounting Plate)

1. Turn CCR local switch to the OFF position.
2. Remove and lock out/tag out primary power to the CCR at the breaker panel.
3. Lock out/tag out the SCO in the maintenance position.
4. Remove the side panel of the CCR, by removing the 8 mounting screws. Be careful as you will also need to disconnect the ground wire attached from the frame to the panel.

Figure 5: Output Lightning Arrestors



5. Loosen the 11/16-inch wire retaining nuts for 200, 201, 203, ST1, ST2 and 202 and disconnect.
6. Remove the (4) #10 x 32 pan-head screws and retain until later.
7. Replace the Input Lightning Arrestor assembly. Replace and tighten the screws on the assembly plate.
8. Connect the wires for 200, 201, 203, ST1, ST2 and 202 and tighten retaining nuts.
9. Connect the ground wire from the frame to the side panel.
10. Put the side panel back on the CCR with the 8 screws.
11. Restore the SCO to the ON position.
12. Restore primary power to the CCR at the breaker panel.
13. Turn the CCR local switch to the REM position.

Figure 6: Output Lightning Arrestors

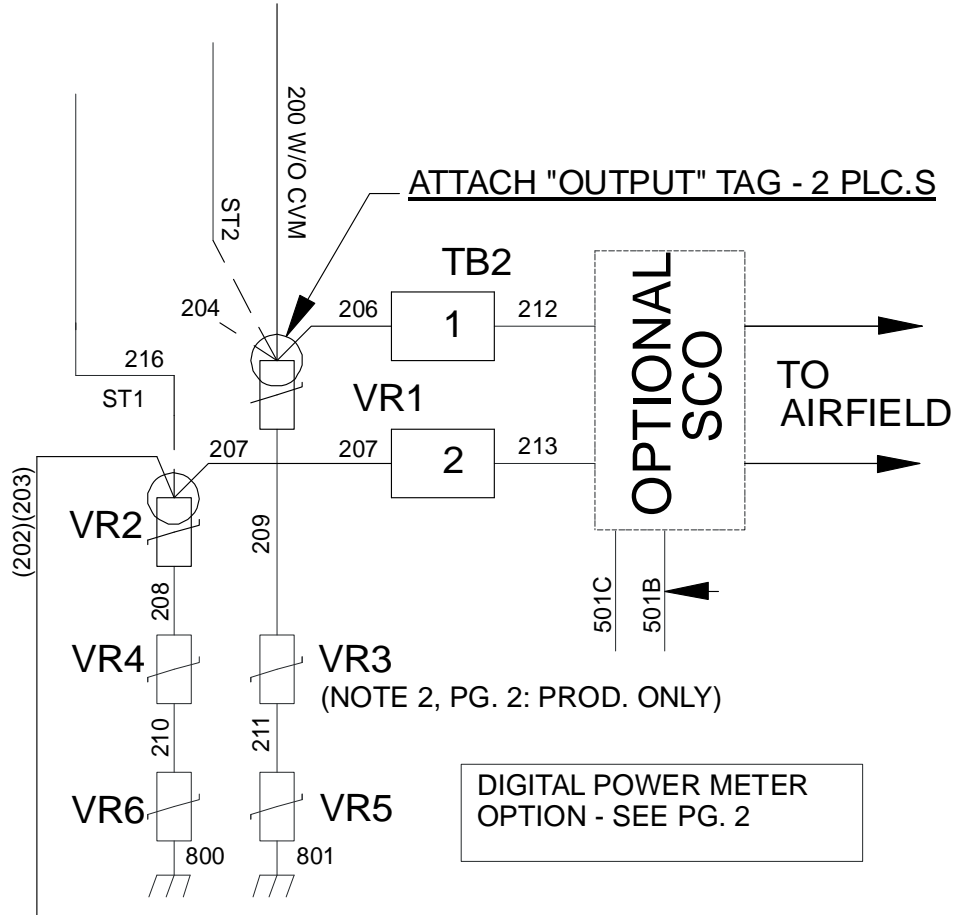

6.0 Schematics

The Main Schematic is broken across Figures 1 and 2.

Figure 1 "43A2845 CCT Schematic Page 1/ Side A" on page 60

Figure 2 "43A2845 CCT Schematic Page 1/ Side B" on page 61

Notes, Accessories and Options are covered in Figures 3 and 4.

Figure 3 "43A2845 CCT Schematic Page 2/ Side A" on page 62

Figure 4 "43A2845 CCT Schematic Page 2/ Side B" on page 63

CCT (Thyristor Controlled) L-828/L-829 Constant Current Regulator Schematics

Figure 1: 43A2845 CCT Schematic Page 1/ Side A

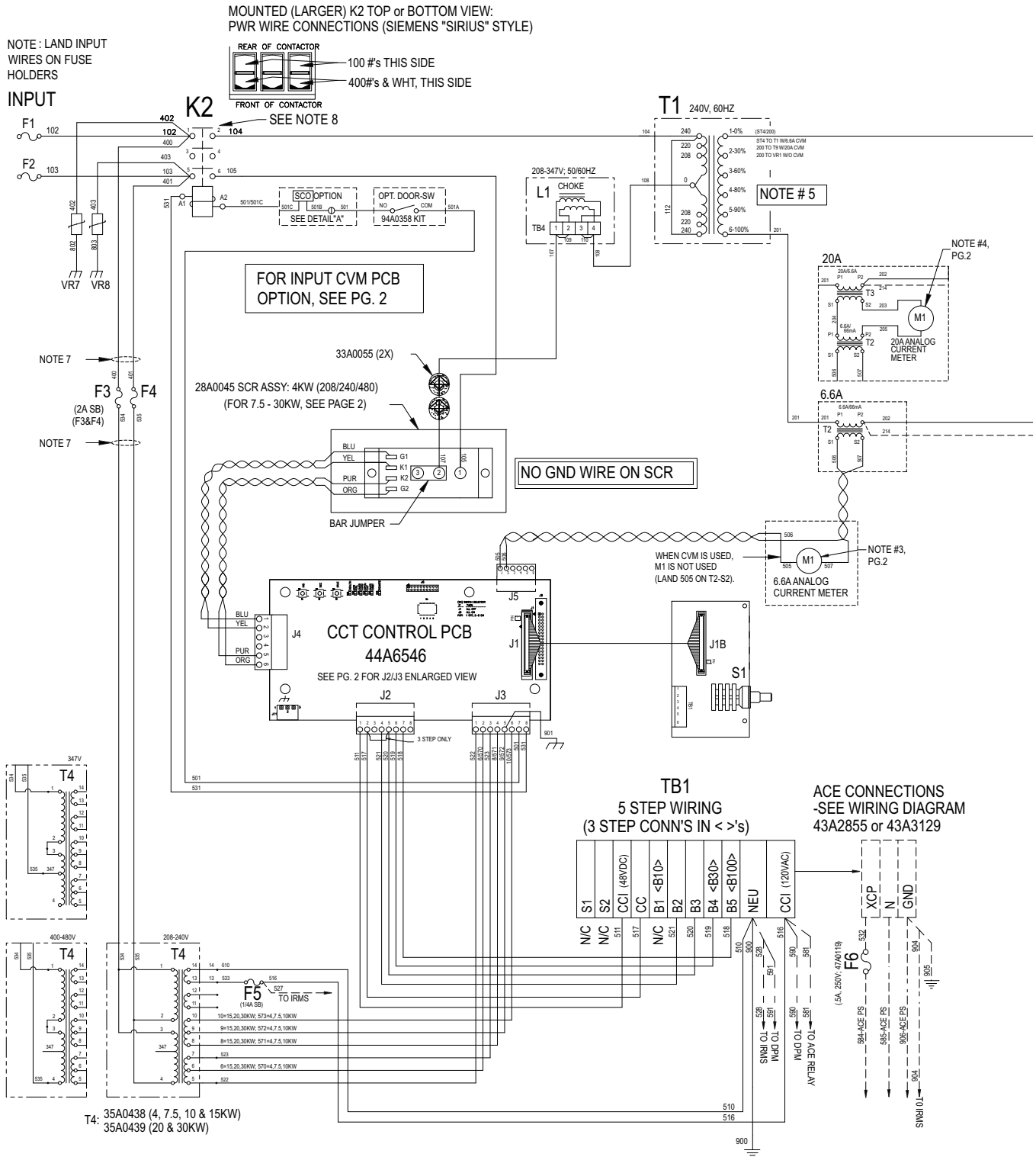
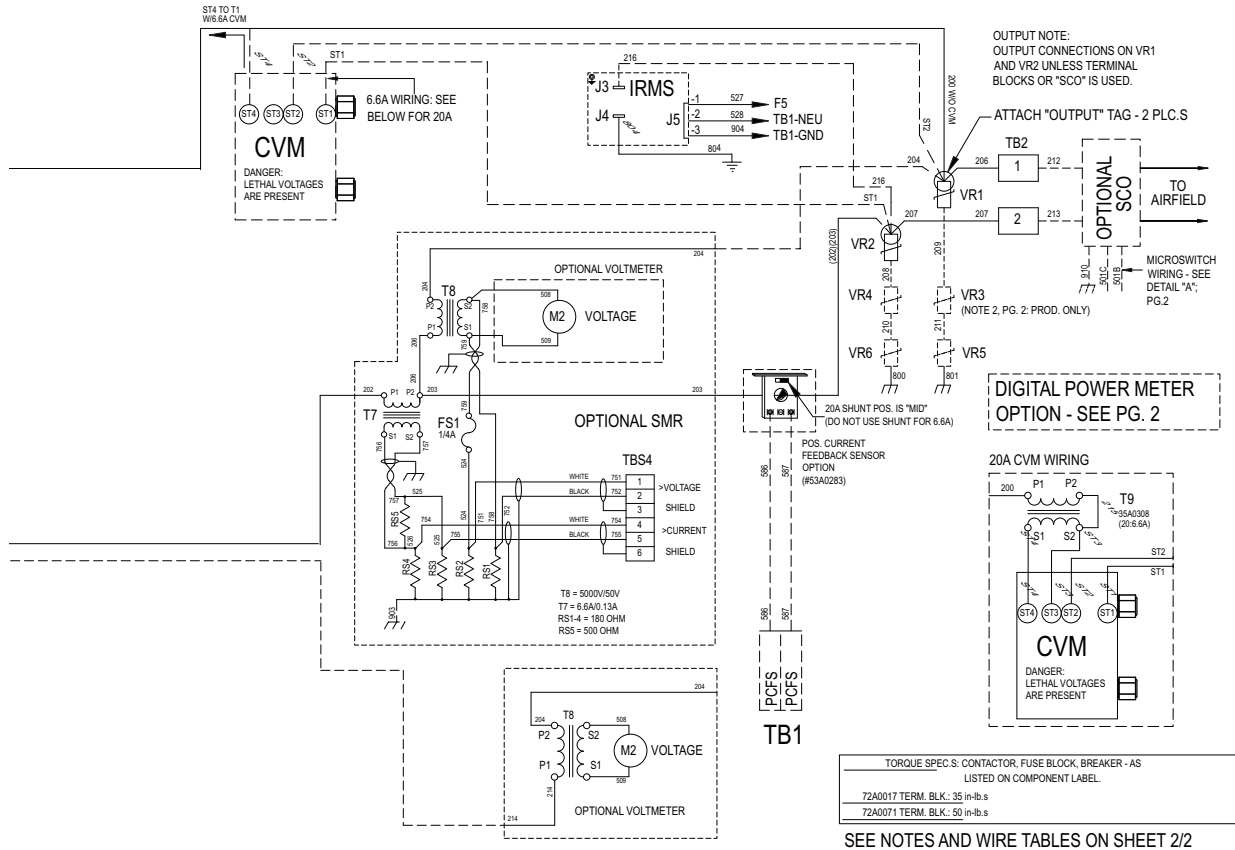
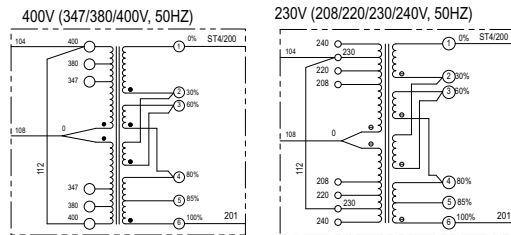
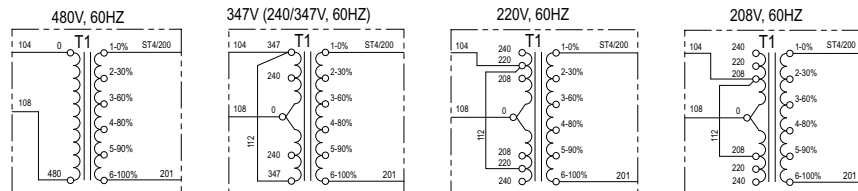

Figure 2: 43A2845 CCT Schematic Page 1/ Side B



OTHER "T1" REGULATOR VOLTAGES :



FOR 380V, 60HZ
WIRING,
SEE 43A3982.

OTHER "L1" CHOKE VOLTAGES

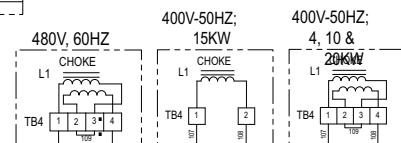

REV. AD
 DRAWING NUMBER:
43A2845

Figure 3: 43A2845 CCT Schematic Page 2/ Side A

J2/J3 WIRING DETAIL ENLARGED

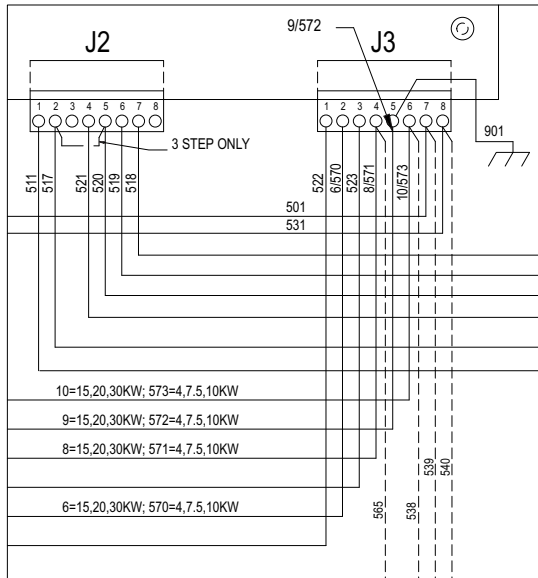

DIGITAL POWER METER OPTION

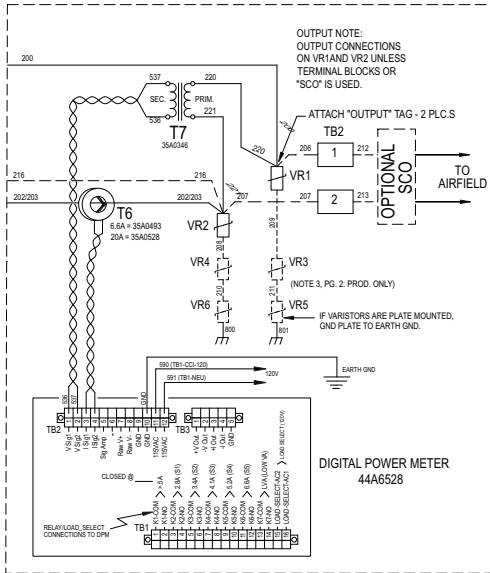

7.5KW, SCR 28A0039,
208-480V (NO GND WIRE)

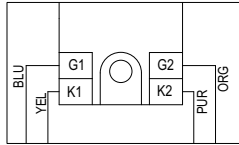

10KW, SCR 28A0038,
208-480V (NO GND WIRE)

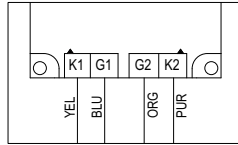

15KW, SCR 28A0034,
208-480V (NO GND WIRE)

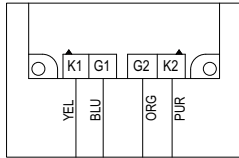

20 & 30KW, SCR 28A0041,
(ALSO 28A0028),
208-480V (NO GND WIRE)

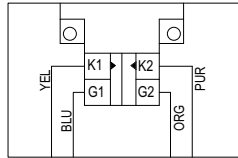

PREVIOUS SCR WIRING

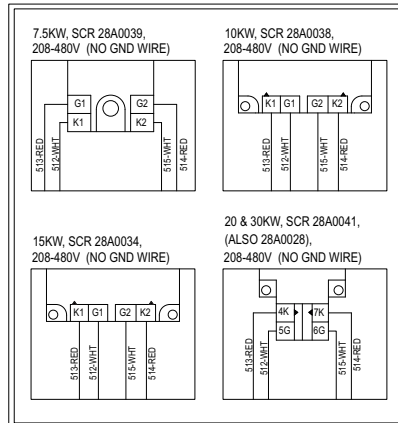

DETAIL "A": SERIES CUT OUT (SCO) OPTION

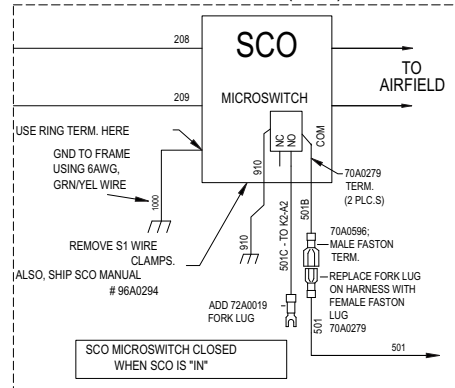

PREVIOUS "MOLDED" STYLE CVM WIRING

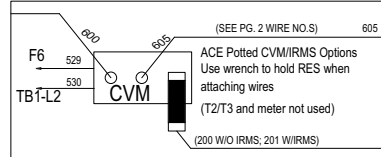

Figure 4: 43A2845 CCT Schematic Page 2/ Side B

100 SERIES WIRES: PRIMARY POWER, 600V, 50/60HZ, 105°C (MIN. SIZE SHOWN)

POWER	208 V	220 V	230 V	240 V	347/380/400V	480 V
4 kW	14AWG 89A0184/9	14AWG 89A0184/9	14AWG 89A0184/9	14AWG 89A0184/9	14AWG 89A0184/9	14AWG 89A0184/9
7.5 kW	8AWG 89A0196/9	8AWG 89A0196/9	8AWG 89A0196/9	8AWG 89A0196/9	8AWG 89A0196/9	14AWG 89A0184/9
10 kW	8AWG 89A0196/9	8AWG 89A0196/9	8AWG 89A0196/9	8AWG 89A0196/9	8AWG 89A0196/9	14AWG 89A0184/9
15 kW	4AWG 89A0198/9	4AWG 89A0198/9	4AWG 89A0198/9	6AWG 89A0197/9	6AWG 89A0197/9	10AWG 89A0195/9
20 kW	1/0AWG 89A0201/9	1/0AWG 89A0201/9	1/0AWG 89A0201/9	2AWG 89A0199/9	2AWG 89A0199/9	6AWG 89A0197/9
30 kW	1/0AWG 89A0201/9	1/0AWG 89A0201/9	1/0AWG 89A0201/9	2AWG 89A0199/9	2AWG 89A0199/9	6AWG 89A0197/9

NOTES:

1. WIRE SIZES:
100-113: PRIMARY POWER, SEE TABLE.
200-217: HIGH VOLT., 12AWG, 25KV, SIL, 89A0086/1.
400-403: MEDIUM CURRENT, 12AWG, 600V, 89A0185/9.
500-560: STD CONTROL, 18AWG, 600V, 89A0182/9.

600-: HI-VOLTAGE, 8AWG, 7.5KV, 89A0202:
OBSOLETE - USE "200" SERIES WIRE.

751-759: SMR, 22AWG, 2 COND. W/SHLD, 89A0126.
800-804: GROUND, 12AWG, 600V, GN/YL, 89A163/5.
900-905: GROUND, 18AWG, 600V, GN/YL, 89A0163/7.
2. SEE BILL OF MATERIALS FOR NUMBER OF MOV'S OR SURGE SUPPRESSORS IN EACH LEG.
3. IF 6.6A REGULATOR IS WIRED W/O METER, LAND 507 ON J5-1 IN PLACE OF 505.
4. IF 20A REGULATOR IS WIRED W/O METER, LAND 205 ON T3-S2 IN PLACE OF 203.
5. IF A JUMPER IS NEEDED FOR ANY CORE LEAD, USE HIGH VOLTAGE 89A0086/1 WIRE.
6. DELETED REV. U.
7. ROUTE THESE WIRES SEPARATE FROM CONTROL WIRING.
8. TORQUE ALL CONTACTOR CONNECTIONS PER CONTACTOR PRODUCT LABEL.

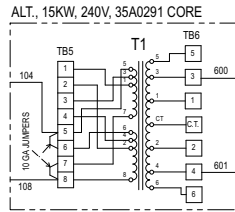
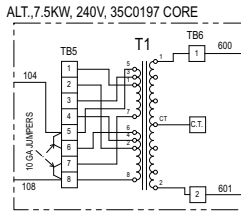

OPTIONAL INPUT CVM PCB

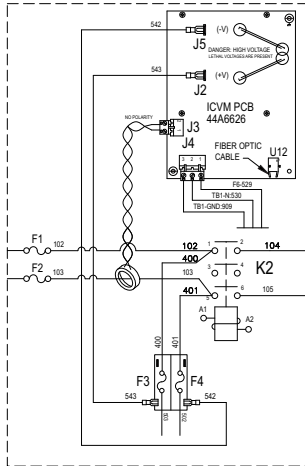

PREVIOUS IRMS W/RES WIRING

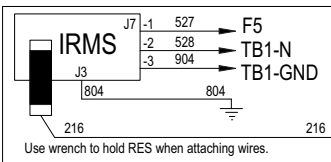

DOC. NO.	DESCRIPTION
44A6313/1-2	CCT WIRE HARNESS, SM. & MED. FRAME
44A6314/1-2	CCT/ACE WIRE HARNESS, SM. & MED. FRAME
94A0349/XXXX	POWER WIRE KIT, CCT CCR
43A2855	WIRING DIAGRAM, ACE1 TO CCT CONTROL PCB
43A3129	WIRING DIAGRAM, ACE2 TO CCT CONTROL PCB

RELATED DOCUMENTS

FOR 380V, 60HZ WIRING, SEE 43A3982.

OPTIONAL SMI & SMR WIRING (REF. KIT #94A0335/X)

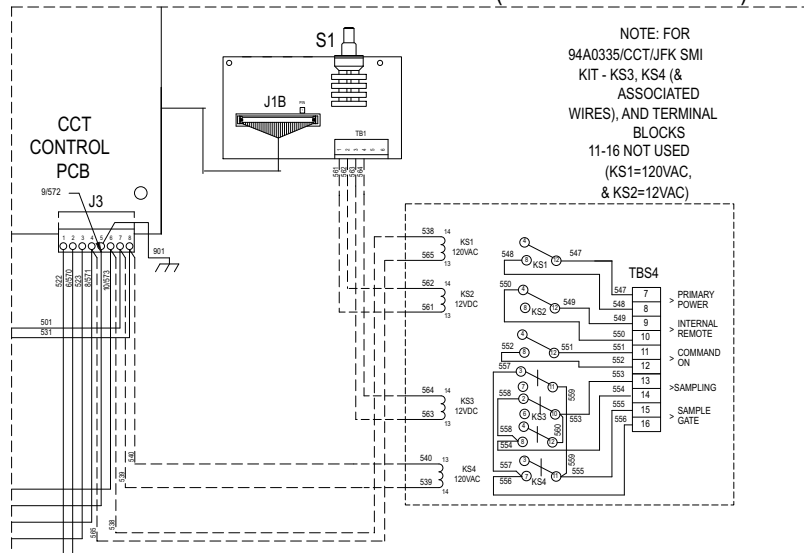

NOTE: FOR 94A0335/CCT/JFK SMI KIT - KS3, KS4 (& ASSOCIATED WIRES), AND TERMINAL BLOCKS 11-16 NOT USED (KS1=120VAC, & KS2=12VAC)

DRAWING NUMBER: **43A2845**

REV: **AD**

7.0 CCT Parts

To order parts, call ADB Safegate Customer Service or your local representative. Use this parts list, and the accompanying illustration, to describe and locate parts correctly.

7.1 L-828/L-829 CCR (4-30 kW) Parts Ordering Codes

See Table 1 for the CCT L-828 and L-829 CCR (4-30 kW) part numbers.

Table 1: L-828/L-829 CCR (4-30 kW/6.6 A) Part Numbers

kW Rating	Output	208 V	220 V	240 V
4 kW	6.6 A	CCT6604-X1XX	CCT6604-X5XX	CCT6604-X2XX
7.5 kW	6.6 A	CCT6607-X1XX	CCT6607-X5XX	CCT6607-X2XX
10 kW	6.6 A	CCT6610-X1XX	CCT6610-X5XX	CCT6610-X2XX
15 kW	6.6 A	CCT6615-X1XX	CCT6615-X5XX	CCT6615-X2XX
20 kW	6.6 A	CCT6620-X1XX	CCT6620-X5XX	CCT6620-X2XX
30 kW	6.6 A	CCT6630-X1XX	CCT6630-X5XX	CCT6630-X2XX

kW Rating	Output	347 V	380 V	400 V	480 V
4 kW	6.6 A	CCT6604-X4XX	CCT6604-XBXX	CCT6604-X6XX	CCT6604-X3XX
7.5 kW	6.6 A	CCT6607-X4XX	CCT6607-XBXX	CCT6607-X6XX	CCT6607-X3XX
10 kW	6.6 A	CCT6610-X4XX	CCT6610-XBXX	CCT6610-X6XX	CCT6610-X3XX
15 kW	6.6 A	CCT6615-X4XX	CCT6615-XBXX	CCT6615-X6XX	CCT6615-X3XX
20 kW	6.6 A	CCT6620X4XX	CCT6620XBXX	CCT6620X6XX	CCT6620-X3XX
30 kW	6.6 A	CCT6630-X4XX	CCT6630-XBXX	CCT6630-X6XX	CCT6630-X3XX

Figure 5: L-828/L-829 CCT Part Ordering Code

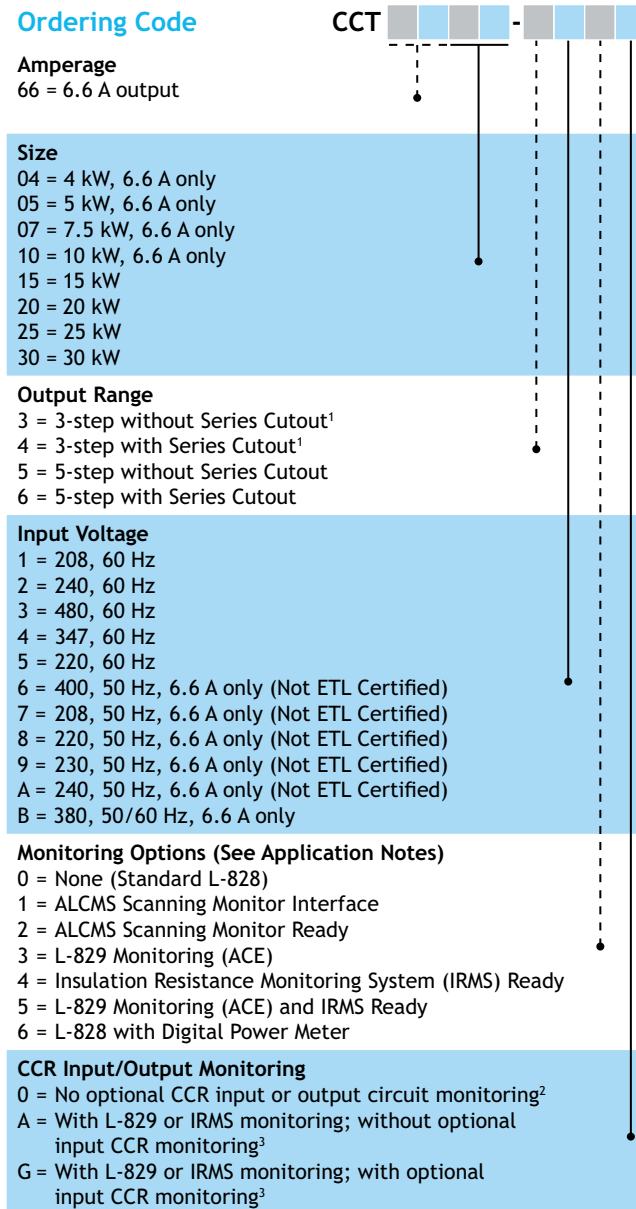

Notes

- ¹ 3-step, 20 A is not standard FAA operation. ADB Airfield Solutions can offer a non-ETL Certified Style 1, Class 2 CCR for dedicated 5.5 A sign circuits or other needs.
- ² Used only with Monitoring Options 0, 1, 2, and 6.
- ³ Used only with Monitoring Options 3 and 5.

7.1.1 L-828/L-829 CCR General Assembly (4-30 kW/208-480 Vac) Parts List

This subsection provides part numbers for the L-828/L-829 CCT CCR (4-30 kW).

NOTE: For parts related to the ACE front display panel, refer to:

- Advanced Control Manual (ACE™) manual 96A0287 or
- Advanced Control Manual (ACE2™) manual 96A0357.

7.1.2 Assembly Parts

7.1.2.1 15-30 KW CCT Regulator Parts

Figure 6: CCT L-828/L-829 CCR Component Parts (Table 2 - Table 4)

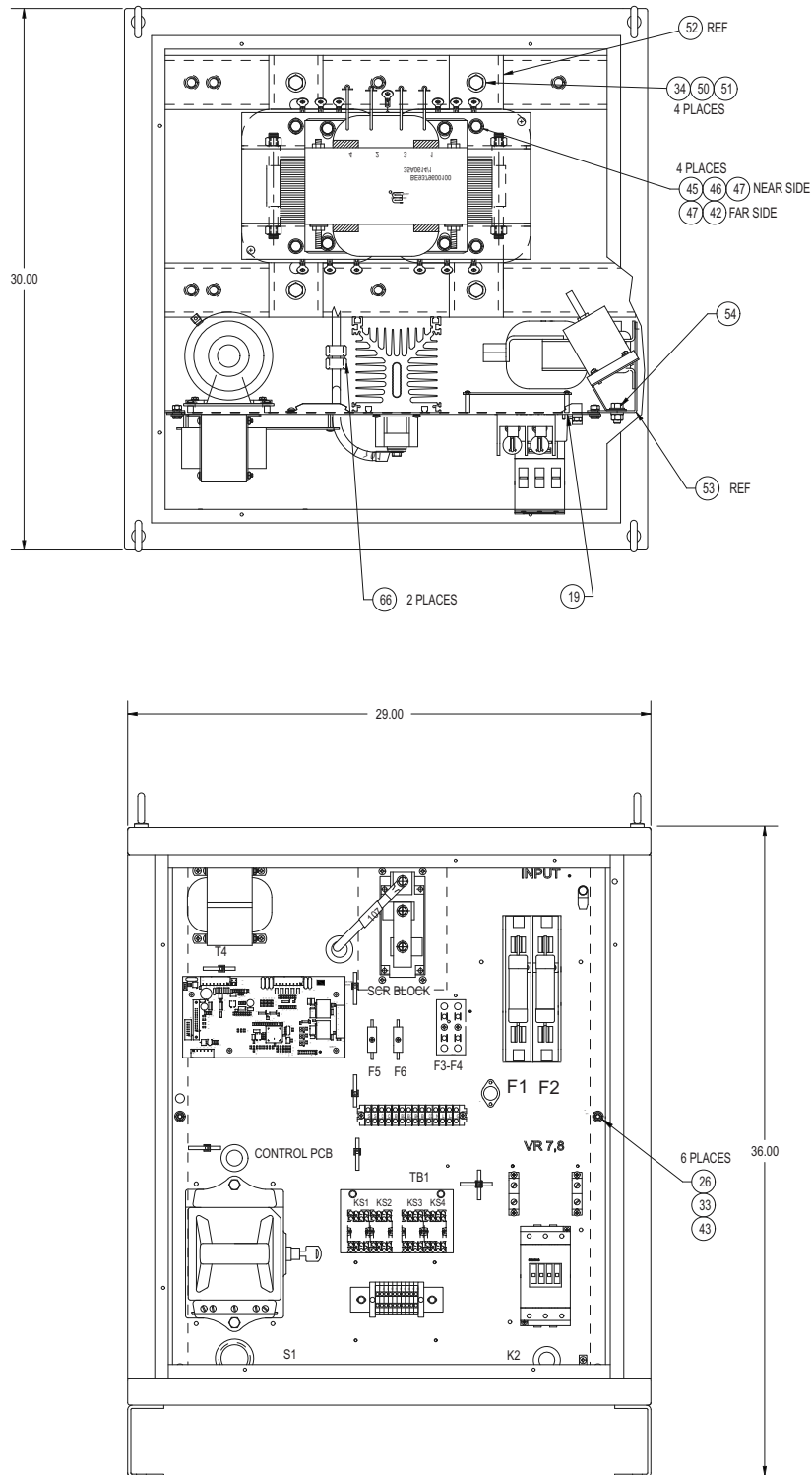

**CCT (Thyristor Controlled) L-828/L-829 Constant Current Regulator
L-828/L-829 CCR (4-30 kW) Parts Ordering Codes**

Table 2: 15-30KW CCT Bill Of Material.

General Assembly Bill Of Material				Quantity Per Suffix (/X10X - /X45X)																		
General Assembly Bill Of Material				208V INPUT					240V INPUT					480V INPUT								
Item No.	Part Number	Part Name/ description	Unit s	No ne	SMI 1X	SM R 2X	L82 9 3X	IRM S 4X	L829 & IRMS 5X	No ne	SMI 1X	SM R 2X	L82 9 3X	IRM S 4X	L829 & IRMS 5X	No ne	SMI 1X	SM R 2X	L82 9 3X	IRM S 4X	L829 & IRMS 5X	
1	66A0304	Clip Washer, 1/2" BOLT, 1/4" THK	EA	-	-	-	-	-	-	-	-	-	-	-	-	--	-	-	-	-	-	
2	66A0039/7	1/4 EXT Lockwasher	EA	8	8	8	8	8	8	8	8	8	8	8	8	8	8	8	8	8	8	
3	35A0346	Voltage TX, 5000 / 50V, 50-60HZ.	EA	0	0	Ref	0	0	0	0	0	Ref	0	0	0	0	0	Ref	0	0	0	
4	35A0614/1	PWR TX/Choke 20KW 6.6A 208/240V COIL	EA	1	1	1	1	1	1	1	1	1	1	1	1	0	0	0	0	0	0	
4A	35A0614/2	PWR TX/Choke 20KW 6.6A 480V COIL	EA	0	0	0	0	0	0	0	0	0	0	0	0	1	1	1	1	1	1	
5	52A0107	Ammeter, 0-10 AMPS, L 828	EA	1	1	1	0	1	0	1	1	1	0	1	0	1	1	1	0	1	0	
13	44A6508/1110	ACE II Internal LCD Display With LOM	EA	0	0	0	1	0	1	0	0	0	1	0	1	0	0	0	1	0	1	
14	42A0523	Local Cont. LBL. 3 OR 5 Step CCT L828	EA	1	1	1	0	1	0	1	1	1	0	1	0	1	1	1	0	1	0	
15	42A0524	Local Cont. LBL. 3 OR 5 Step CCT L829	EA	0	0	0	1	0	1	0	0	0	1	0	1	0	0	0	1	0	1	
16	44D1476/X	LC 3 OR 5-Step Switch PCB TCC	EA	1	1	1	1	1	1	1	1	1	1	1	1	1	1	1	1	1	1	
17	44A6056/2	Cabinet Frame Assy, Medium URC, CCR	EA	1	1	1	1	1	1	1	1	1	1	1	1	1	1	1	1	1	1	
18	44A6058	Door Assy, Medium URC CCR	EA	Ref	Ref	Ref	Ref	Ref	Ref	Ref	Ref	Ref	Ref	Ref	Ref	Ref	Ref	Ref	Ref	Ref	Ref	
19	SEE CHART	Component Plate Assy, 20 KW Thyristor Controlled CCR	EA	-	-	-	-	-	-	-	-	-	-	-	-	-	-	-	-	-	-	
22	60A2658/1	Display Panel, Analog, L 828	EA	1	1	1	0	1	0	1	1	1	0	1	0	1	1	1	0	1	0	
23	63A0548	Knob For 1/4" Shaft	EA	1	1	1	1	1	1	1	1	1	1	1	1	1	1	1	1	1	1	
25	42A0480	Output Current Label, Analog URC CCR	EA	1	1	1	0	1	0	1	1	1	0	1	0	1	1	1	0	1	0	
26	64A0173/10	1/4-20 X 5/8 Hex Head	EA	11	11	19	11	11	11	11	11	19	11	11	11	11	11	19	11	11	11	
29	64A0198/6	6-32 X 3/8 Pan Head Phil	EA	0	0	0	10	0	10	0	0	0	10	0	10	0	0	0	10	0	10	
30	64A0947	1/2-13 Eyebolt, 1.5 LG., 1.19 I.D., 2600 LB.	EA	4	4	4	4	4	4	4	4	4	4	4	4	4	4	4	4	4	4	

General Assembly Bill Of Material Order Of Entry: Numerical Order Of All Components. Line Every Fifth Component At A Minimum. Rm Numbers Listed Last				Quantity Per Suffix (/X10X - /X45X)																	
General Assembly Bill Of Material			Input Voltage	208V INPUT						240V INPUT						480V INPUT					
			Monitoring Options	No ne	SMI	SM R	L82 9	IRM S	L829 & IRMS	No ne	SMI	SM R	L82 9	IRM S	L829 & IRMS	No ne	SMI	SM R	L82 9	IRM S	L829 & IRMS
31	65A0015/24	1/4-20 Hex Nut	EA	8	8	16	8	8	8	8	8	16	8	8	8	8	8	16	8	8	8
33	66A0026/24	1/4 SPLIT Lockwasher	EA	15	15	23	15	15	15	15	15	23	15	15	15	15	15	23	15	15	15
C 34	66A0026/33	1/2 SPLIT Lockwasher	EA	4	4	4	4	4	4	4	4	4	4	4	4	4	4	4	4	4	4
39	72A0010	Ground Lug	EA	1	1	1	1	1	1	1	1	1	1	1	1	1	1	1	1	1	1
41	44A6006/0007	Fiber Optic Cable, 1mm Plastic (7 FT. LG.)	EA	0	0	0	1	2	3	0	0	0	1	2	3	0	0	0	1	2	3
42	65A0015/29	3/8-16 Hex Nut	EA	8	8	8	8	8	8	8	8	8	8	8	8	8	8	8	8	8	8
43	66A0015/24	1/4 Flatwasher	EA	6	6	6	6	6	6	6	6	6	6	6	6	6	6	6	6	6	6
44	89A0096	Ribbon Cable 28AWG 26COND	FT	2	2	2	2	2	2	2	2	2	2	2	2	2	2	2	2	2	2
45	64A0176/16	3/8-16 X 1 IN. LG. HEX Head Bolt	EA	7	7	7	7	7	7	7	7	7	7	7	7	7	7	7	7	7	7
46	66A0026/29	3/8 Split Lock Washer	EA	11	11	11	11	11	11	11	11	11	11	11	11	11	11	11	11	11	11
47	66A0015/29	3/8 Flat Washer	EA	15	15	15	15	15	15	15	15	15	15	15	15	15	15	15	15	15	15
C 50	64A0178/36	1/2-13 X 2 1/4 HX HD	EA	4	4	4	4	4	4	4	4	4	4	4	4	4	4	4	4	4	4
C 51	66A0015/33	1/2 Flat Washer	EA	4	4	4	4	4	4	4	4	4	4	4	4	4	4	4	4	4	4
C 52	60A3137	XFMR Mounting Channel	EA	2	2	2	2	2	2	2	2	2	2	2	2	2	2	2	2	2	2
53	60A2857	Medium Cabinet Vertical Angle, Top Loading	EA	Ref	Ref	Ref	Ref	Ref	Ref	Ref	Ref	Ref	Ref	Ref	Ref	Ref	Ref	Ref	Ref	Ref	Ref
54	94A0433/6	Surge Arr. Kit, Sig. SRS. Regulator, 6KV	EA	1	1	1	1	1	1	1	1	1	1	1	1	1	1	1	1	1	1
55	----	----	EA	0	0	0	0	0	0	0	0	0	0	0	0	0	0	0	0	0	0
56	44A6313/2	Harn Assy, L828/829, SIG. CCT Med. Frame	EA	1	1	1	1	1	1	1	1	1	1	1	1	1	1	1	1	1	1
57	44A6563/2	Harn Assy, ACEII, SIG. CCT Large Frame	EA	0	0	0	1	0	1	0	0	0	1	0	1	0	0	0	1	0	1
58	91A0033	Label, L828 Danger High Voltage	EA	2	2	2	2	2	2	2	2	2	2	2	2	2	2	2	2	2	2
59	42B0269	Label, L828, Identification / Serialization	EA	1	1	1	1	1	1	1	1	1	1	1	1	1	1	1	1	1	1
61	60A2657	EMI Shield, ACE Combo Box	EA	0	0	0	1	0	1	0	0	0	1	0	1	0	0	0	1	0	1
62	94A0349/4XXX	Power Wiring Kit, Signature Series Regulator (T/C)	1 EA	/42 02	/42 02	/42 02	/42 01	/42 02	/42 01	/42 42	/42 42	/42 42	/42 41	/42 42	/42 41	/44 82	/44 82	/44 82	/44 81	/44 82	/44 81
C 63	33A0026	Choke 20 KW 60HZ	EA	Ref	Ref	Ref	Ref	Ref	Ref	Ref	Ref	Ref	Ref	Ref	Ref	Ref	Ref	Ref	Ref	Ref	Ref

**CCT (Thyristor Controlled) L-828/L-829 Constant Current Regulator
L-828/L-829 CCR (4-30 kW) Parts Ordering Codes**

General Assembly Bill Of Material Order Of Entry: Numerical Order Of All Components. Line Every Fifth Component At A Minimum. Rm Numbers Listed Last				Quantity Per Suffix (/X10X - /X45X)																		
General Assembly Bill Of Material				Input Voltage	208V INPUT						240V INPUT						480V INPUT					
					Monitoring Options	No ne	SMI	SM R	L82 9	IRM S	L829 & IRMS	No ne	SMI	SM R	L82 9	IRM S	L829 & IRMS	No ne	SMI	SM R	L82 9	IRM S
64	70A0327	PCB Ribbon Conn 26 PIN Keyed	EA	2	2	2	2	2	2	2	2	2	2	2	2	2	2	2	2	2		
65	64A0176/20	3/8-16 X 1&1/4 HX HD	EA	2	2	2	2	2	2	2	2	2	2	2	2	2	2	2	2	2		
66	33A0055	Ferrite Core	EA	2	2	2	2	2	2	2	2	2	2	2	2	2	2	2	2	2		
67	60A3004	Choke MTG. Plate, 20 KW CCT	EA	Ref	Ref	Ref	Ref	Ref	Ref	Ref	Ref	Ref	Ref	Ref	Ref	Ref	Ref	Ref	Ref	Ref		
68	65A0347/4	1/4-20 Nylon Insert SS Nut	EA	8	8	8	8	8	8	8	8	8	8	8	8	8	8	8	8	8		
69	62A3205	Relay Mounting Plate	EA	0	0	0	1	0	1	0	0	0	1	0	1	0	0	0	1	0	1	

Table 3: Configuration Bill of Material, 30kw CCT

Configuration Bill of Material, 30kw CCT				208V INPUT						220/240V INPUT						480V INPUT					
Item No.	Part Number	Part Name/Description	Units	Non e	SMI	SM R	L82 9	IRM S	L829 & IRMS	Non e	SMI	SM R	L82 9	IRM S	L829 & IRMS	Non e	SMI	SM R	L82 9	IRM S	L829 & IRMS
				/X1 0X	/X1 1X	/X1 2X	/X1 3X	/X1 4X	/X1 5X	/X2 0X	/X2 1X	/X2 2X	/X2 3X	/X2 4X	/X2 5X	/X3 0X	/X3 1X	/X3 2X	/X3 3X	/X3 4X	/X3 5X
4	35A0613/1	Power Transformer/Choke 30KW 6.6A 208/240V COIL	1 Per Suffix	/X1 0	/X1 1	/X1 2	/X1 3	/X1 4	/X1 5	/X2 0	/X2 1	/X2 2	/X2 3	/X2 4	/X2 5	/X3 0	/X3 1	/X3 2	/X3 3	/X3 4	/X3 5
4A	35A0613/2	PWR TX/Choke 30KW 6.6A 480V Coil (30 kW CCR)																			

Table 4: Configuration Bill of Material, 15KW CCT

Configuration Bill of Material, 15KW CCT				208V INPUT						220/240V INPUT						480V INPUT					
Item No.	Part Number	Part Name/description	Units	Non e	SMI	SM R	L82 9	IRM S	L829 & IRMS	Non e	SMI	SM R	L82 9	IRM S	L829 & IRMS	Non e	SMI	SM R	L82 9	IRM S	L829 & IRMS
				/X1 0X	/X1 1X	/X1 2X	/X1 3X	/X1 4X	/X1 5X	/X2 0X	/X2 1X	/X2 2X	/X2 3X	/X2 4X	/X2 5X	/X3 0X	/X3 1X	/X3 2X	/X3 3X	/X3 4X	/X3 5X
4	35B0465	PWR TX/Choke 30KW 6.6A 208/240V Coil	1 Per Suffix																		
4A	35B0465/480	PWR TX/Choke 30KW 6.6A 480V Coil (15 kW CCR)	1 Per Suffix																		
34	66A0026/33	1/2 Split Lockwasher	EA	8	8	8	8	8	8	8	8	8	8	8	8	8	8	8	8	8	8
50	64A0178/36	1/2-13 X 2 1/4 HX HD	EA	8	8	8	8	8	8	8	8	8	8	8	8	8	8	8	8	8	8
51	66A0015/33	1/2 FLAT WASHER	EA	8	8	8	8	8	8	8	8	8	8	8	8	8	8	8	8	8	8
52	60A3137	XFMR MOUNTING CHANNEL	EA	4	4	4	4	4	4	4	4	4	4	4	4	4	4	4	4	4	4

62	94A0349 /3XXX	Power Wiring Kit, Signature Series Regulator (T/C)	1 EA	/32 02	/32 02	/32 02	/32 01	/32 02	/32 01	/32 42	/32 42	/32 42	/32 41	/32 42	/32 41	/34 82	/34 82	/34 82	/34 81	/34 82	/34 81
63	33A0019	Choke 15KW LC 60/50HZ	EA	1	1	1	1	1	1	1	1	1	1	1	1	1	1	1	1	1	1

**CCT (Thyristor Controlled) L-828/L-829 Constant Current Regulator
L-828/L-829 CCR (4-30 kW) Parts Ordering Codes**

Table 5: 15-30KW CCT Configured Component Plates

General Assembly Bill Of Material Order Of Entry: Numerical Order Of All Components. Line Every Fifth Component At A Minimum. Rm Numbers Listed Last				Quantity Per Suffix (/3XXX) 3 Step Without S1 Cutout																	
General Assembly Bill Of Material				208V INPUT						220/240V INPUT						480V INPUT					
				Non e	SMI	SM R	L82 9	IRM S	L829 & IRMS	Non e	SMI	SM R	L82 9	IRM S	L829 & IRMS	Non e	SMI	SM R	L82 9	IRM S	L829 & IRMS
ITE M NO.	Part Number	Part Name/Description	Units	/310 X	/31 1X	/31 2X	/31 3X	/314 X	/31 5X	/32 0X	/32 1X	/32 2X	/323 X	/32 4X	/32 5X	/33 0X	/331 X	/33 2X	/33 3X	/33 4X	/33 5X
19	44A630 7/XXX	Component Plate Assy., 20 KW T/C URC CCR	1 Per Suffix	/310	/31 1	/31 2	/31 3	/314	/31 5	/32 0	/32 1	/32 2	/323	/32 4	/32 5	/33 0	/331	/33 2	/33 3	/33 4	/33 5
19	44A630 6/XXX	Component Plate Assy., 30 KW T/C URC CCR																			
19	44A630 8/XXX	Component Plate Assy., 15 KW T/C URC CCR																			

Table 6: 15-30KW CCT Configured Component Plates

General Assembly Bill Of Material Order Of Entry: Numerical Order Of All Components. Line Every Fifth Component At A Minimum. Rm Numbers Listed Last				Quantity Per Suffix (/4XXX) 3 Step With S1 Cutout																	
General Assembly Bill Of Material				208V INPUT						220/240V INPUT						480V INPUT					
				Non e	SMI	SM R	L82 9	IRM S	L829 & IRMS	Non e	SMI	SM R	L82 9	IRM S	L829 & IRMS	Non e	SMI	SM R	L82 9	IRM S	L829 & IRMS
Item	Part Number	Part Name/description	Units	/41 0X	/41 1X	/41 2X	/41 3X	/41 4X	/41 5X	/42 0X	/42 1X	/42 2X	/42 3X	/42 4X	/42 5X	/43 0X	/43 1X	/43 2X	/43 3X	/43 4X	/43 5X
19	44A630 7/XXX	Component Plate Assy., 20 KW T/C URC CCR	1 Per Suffix	/41 0	/41 1	/41 2	/41 3	/41 4	/41 5	/42 0	/42 1	/42 2	/42 3	/42 4	/42 5	/43 0	/43 1	/43 2	/43 3	/43 4	/43 5
19	44A630 6/XXX	Component Plate Assy., 30 KW T/C URC CCR																			
19	44A630 8/XXX	Component Plate Assy., 15 KW T/C URC CCR																			

Table 7: 15-30KW CCT Configured Component Plates

General Assembly Bill Of Material Order Of Entry: Numerical Order Of All Components. Line Every Fifth Component At A Minimum. Rm Numbers Listed Last				Quantity Per Suffix (/5XXX) 5 Step Without S1 Cutout																				
General Assembly Bill Of Material				208V INPUT						220/240V INPUT						400V INPUT		480V INPUT						
				No ne	SM I	SM R	L82 9	IR MS	L82 9 & IRMS	No ne	SM I	SM R	L82 9	IR MS	L82 9 & IRMS	No ne	L82 9	L82 9 & IRMS	NO NE	SM I	SM R	L82 9	IR MS	L82 9 & IRMS
Item No.	Part Number	Part Name/description	Units	/51 0X	/51 1X	/51 2X	/51 3X	/51 4X	/51 5X	/52 0X	/52 1X	/52 2X	/52 3X	/52 4X	/52 5X	/56 0X	/56 3X	/56 5X	/53 0X	/53 1X	/53 2X	/53 3X	/53 4X	/53 5X
19	44A630 7/XXX	COMPONENT PLATE ASSY., 20 KW T/C URC CCR	1 Per Suffix	/51 0	/51 1	/51 2	/51 3	/51 4	/51 5	/52 0	/52 1	/52 2	/52 3	/52 4	/52 5	/56 0	/56 3	/56 5	/53 0	/53 1	/53 2	/53 3	/53 4	/53 5

19	44A630 6/XXX	COMPONENT PLATE ASSY., 30 KW T/C URC CCR	
19	44A630 8/XXX	COMPONENT PLATE ASSY., 15 KW T/C URC CCR	

Table 8: 15-30KW CCT Configured Component Plates

General Assembly Bill Of Material Order Of Entry: Numerical Order Of All Components. Line Every Fifth Component At A Minimum. Rm Numbers Listed Last				Quantity Per Suffix (/6XXX) 5 Step With S1 Cutout																				
General Assembly Bill Of Material				208V INPUT					220/240V INPUT					400V INPUT			480V INPUT							
				No ne	SM I	SM R	L82 9	IR MS	L82 9 & IRMS	No ne	SM I	SM R	L82 9	IR MS	L829 & IRMS	NO NE	L82 9	L82 9 & IRMS	No ne	SM I	SM R	L82 9	IR MS	L82 9 & IRMS
Item No.	Part Number	Part Name/description	Unit s	/61 0X	/61 1X	/61 2X	/61 3X	/61 4X	/61 5X	/62 0X	/62 1X	/62 2X	/62 3X	/62 4X	/62 5X	/66 0X	/66 3X	/66 5X	/63 0X	/63 1X	/63 2X	/63 3X	/63 4X	/63 5X
19	44A630 7/XXX	Component Plate Assy., 20 KW T/C URC CCR	1 Per Suffix	/61 0	/61 1	/61 2	/61 3	/61 4	/61 5	/62 0	/62 1	/62 2	/62 3	/62 4	/62 5	/66 0	/66 3	/66 5	/63 0	/63 1	/63 2	/63 3	/63 4	/63 5
19	44A630 6/XXX	Component Plate Assy., 30 KW T/C URC CCR																						
19	44A630 8/XXX	Component Plate Assy., 15 KW T/C URC CCR																						

Figure 7: 15-30 KW Component Plate Parts (front)

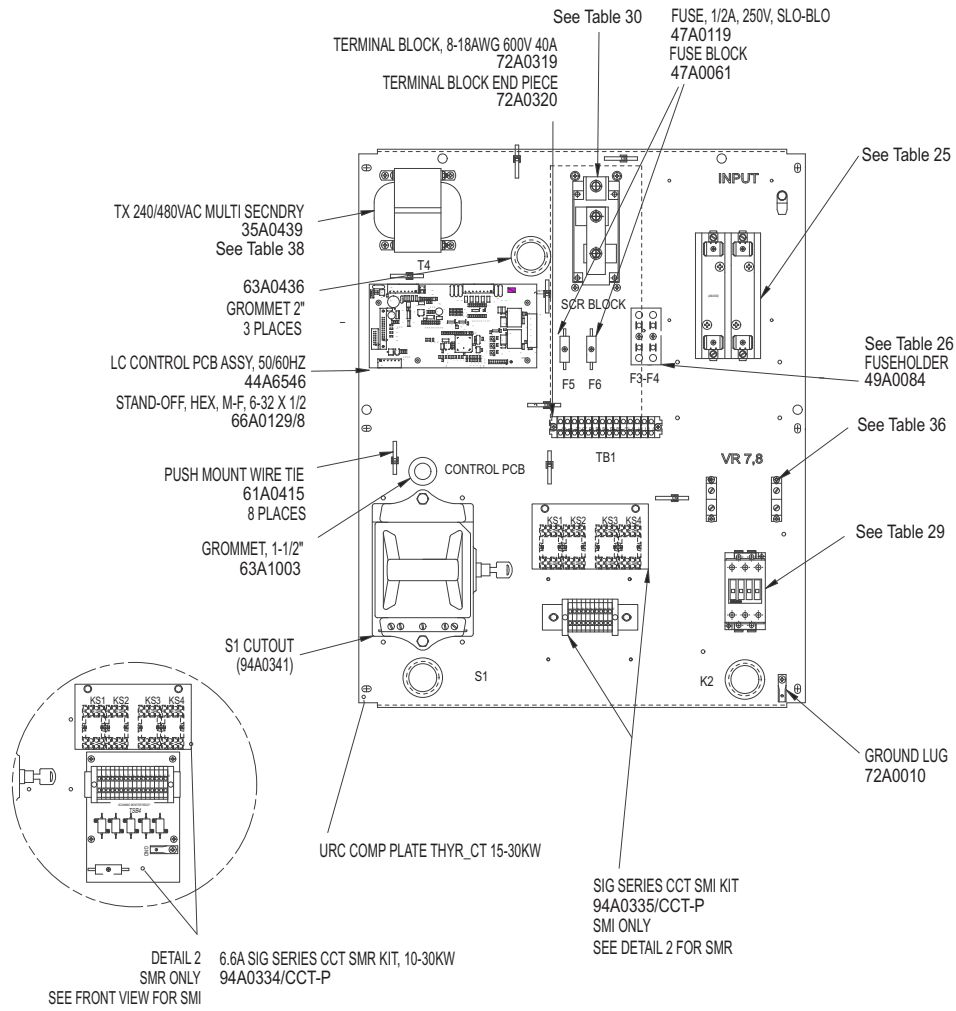
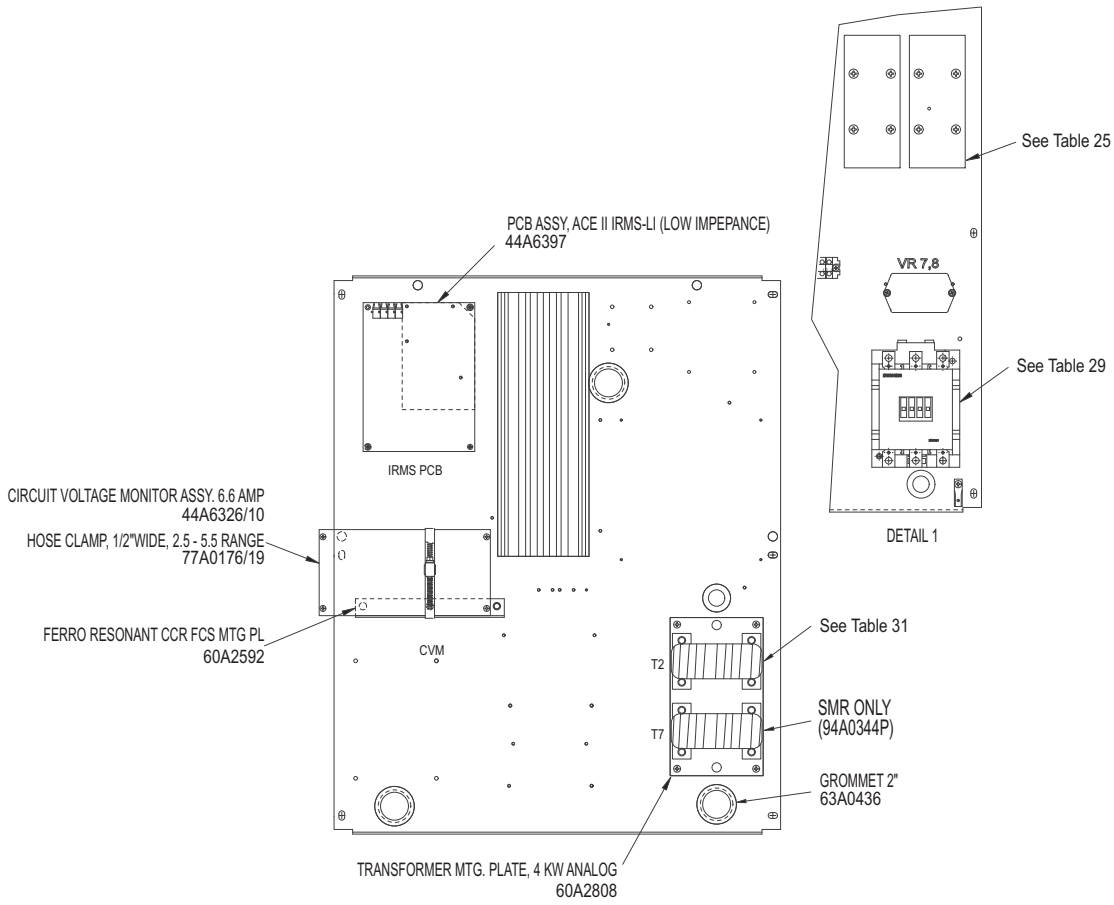

Figure 8: 15-30 KW Component Plate Parts (back)



7.1.2.2 4-10 kW CCT Regulator Parts

Figure 9: 4, 7.5 and 10 kW CCT Diagrams (Table 9 - Table 11)

ATTACH VERTICAL ANGLES WITH EXTERNAL WASHERS BEARING ON BOTH PAINTED PANELS TO PROVIDE CONTINUITY TO THE FRAME.

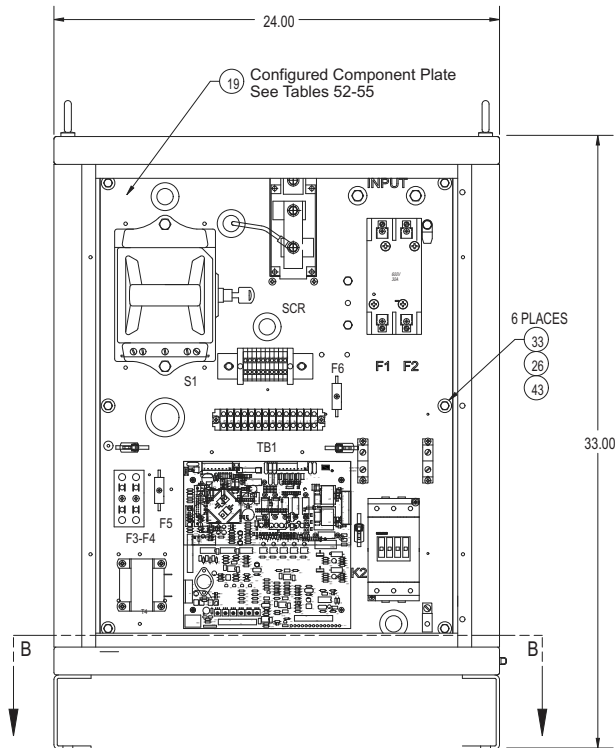
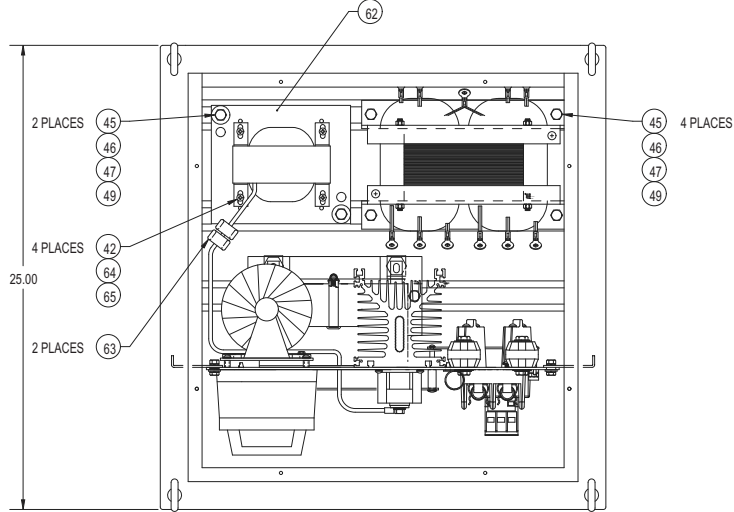

Table 9: 4, 7.5, 10 kW CCT General Assembly Bill of Material

General Assembly Bill Of Material Order Of Entry: Numerical Order Of All Components. Line Every Fifth Component At A Minimum. Rm Numbers Listed Last			QUANTITY PER SUFFIX (/X10X - /X35X)																						
General Assembly Bill Of Material 7.5KW CCT Final Assembly Shown			Input Voltage: Monit oring Options:	208V INPUT					240V INPUT					400V INPUT			480V INPUT								
Item No	Part Number	Part Name/ Description		UNIT S	/X1 0X	/X1 1X	/X1 2X	L82 9 3X	IR MS 4X	L82 9 & IR MS 5X	/X2 0X	/X2 1X	/X2 2X	L82 9 3X	IR MS 4X	L829 & IRM S 5X	/X6 0X	L82 9 3X	L82 9 & IR MS 5X	/X3 0X	/X3 1X	/X3 2X	L82 9 3X	IR MS 4X	L82 9 & IR MS 5X
1	----	----	EA																						
2	66A0039/7	1/4 EXT Lockwasher	EA	8	8	8	8	8	8	8	8	8	8	8	8	8	8	8	8	8	8	8	8	8	8
3	35A0405	SD TX 1500/50V 50/60 HZ	EA	0	0	Ref	0	0	0	0	0	Ref	0	0	0	0	0	0	0	0	0	Ref	0	0	0
4	35B0463	PWR TX 7.5KW 6.6A 208/240V COIL	EA	1	1	1	1	1	1	1	1	1	1	1	1	0	0	0	0	0	0	0	0	0	0
4A	35B0463/4 80	PWR TX 7.5KW 6.6A 480V COIL	EA	0	0	0	0	0	0	0	0	0	0	0	0	0	0	0	1	1	1	1	1	1	1
4B	35A0752	PWR TX 7.5KW 6.6A 400V COIL	EA	0	0	0	0	0	0	0	0	0	0	0	0	1	1	1	0	0	0	0	0	0	0
5	52A0107	Ammeter 3PB- AMC-100X 0- 10A	EA	1	1	1	0	1	0	1	1	1	0	1	0	1	0	0	1	1	1	0	1	0	0
13	44A6508/1 110	ACE II Internal LCD Display with LOM	EA	0	0	0	1	0	1	0	0	0	1	0	1	0	1	1	0	0	0	0	1	0	1
14	42A0523	Label, Local Control, 3 OR 5 Step CCT, L828	EA	1	1	1	0	1	0	1	1	1	0	1	0	1	0	0	1	1	1	0	1	0	0
15	42A0524	Label, Local Control, 3 OR 5 Step CCT, L829	EA	0	0	0	1	0	1	0	0	0	1	0	1	0	1	1	0	0	0	0	1	0	1
16	44A1476/X	LC 3 OR 5-Step Switch PCB TCC	EA	1	1	1	1	1	1	1	1	1	1	1	1	1	1	1	1	1	1	1	1	1	1
17	44A6051/X	Cabinet Frame Assy, Small URC, CCR	EA	1	1	1	1	1	1	1	1	1	1	1	1	1	1	1	1	1	1	1	1	1	1
18	44A6050	Door Assy., Small URC CCR	EA	Ref	Ref	Ref	Ref	Ref	Ref	Ref	Ref	Ref	Ref	Ref	Ref	Ref	Ref	Ref	Ref	Ref	Ref	Ref	Ref	Ref	
19	SEE CHART	Component Plate Assy., 4 KW Thyristor Controlled CCR	EA	-	-	-	-	-	-	-	-	-	-	-	-	-	-	-	-	-	-	-	-	-	
22	60A2658/1	Display Panel, Analog, L 828	EA	1	1	1	0	1	0	1	1	1	0	1	0	1	0	0	1	1	1	0	1	0	
23	63A0548	Knob For 1/4" SHAFT	EA	1	1	1	1	1	1	1	1	1	1	1	1	1	1	1	1	1	1	1	1	1	

**CCT (Thyristor Controlled) L-828/L-829 Constant Current Regulator
L-828/L-829 CCR (4-30 kW) Parts Ordering Codes**

25	42A0480	Output Current Label, Analog URC CCR	EA	1	1	1	0	1	0	1	1	1	0	1	0	1	0	0	1	1	1	0	1	0
26	64A0173/10	1/4-20 X 5/8 Hex Head	EA	19	19	23	19	19	19	19	19	23	19	19	19	19	19	19	19	19	23	19	19	19
29	65A0347/4	1/4-20 Nylon Insert SS Nut (NYLOCK)	EA	12	12	12	12	12	12	12	12	12	12	12	12	12	12	12	12	12	12	12	12	12
30	64A0947	1/2-13 Eyebolt, 1.5 LG., 1.19 I.D., 2600 LB.	EA	4	4	4	4	4	4	4	4	4	4	4	4	4	4	4	4	4	4	4	4	4
31	65A0015/24	1/4-20 Hex Nut	EA	8	8	8	8	8	8	8	8	8	8	8	8	8	8	8	8	8	8	8	8	8
32	64A0178/16	1/2-13 X 1 IN LG. Hex Head Bolt	EA	4	4	4	4	4	4	4	4	4	4	4	4	4	4	4	4	4	4	4	4	4
33	66A0026/24	1/4 Split Lockwasher	EA	15	15	15	15	15	15	15	15	15	15	15	15	15	15	15	15	15	15	15	15	15
34	66A0026/33	1/2 Split Lockwasher	EA	4	4	4	4	4	4	4	4	4	4	4	4	4	4	4	4	4	4	4	4	4
39	72A0010	Ground Lug	EA	1	1	1	1	1	1	1	1	1	1	1	1	1	1	1	1	1	1	1	1	1
41	44A6006/0007	Fiber Optic Cable, 1mm Plastic (7 FT. Long)	EA	0	0	0	1	2	3	0	0	0	1	2	3	0	1	3	0	0	0	1	2	3
42	64A0177/6	10-32 X 3/8 Pan HD PHIL	EA	4	4	8	4	4	4	4	4	8	4	4	4	4	4	4	4	4	8	4	4	4
43	66A0015/24	1/4 Flat Washer	EA	6	6	10	6	6	6	6	6	10	6	6	6	6	6	6	6	6	10	6	6	6
44	89A0096	Ribbon Cable 28AWG 26COND	FT	2	2	2	2	2	2	2	2	2	2	2	2	2	2	2	2	2	2	2	2	2
45	64A0176/16	3/8-16 X 1 IN. LG. Hex Head Bolt	EA	6	6	Ref	6	6	6	6	6	Ref	6	6	6	6	6	6	6	6	Ref	6	6	6
46	66A0026/29	3/8 Split Lock Washer	EA	6	6	Ref	6	6	6	6	6	Ref	6	6	6	6	6	6	6	6	Ref	6	6	6
47	66A0015/29	3/8 Flat Washer	EA	6	6	Ref	6	6	6	6	6	Ref	6	6	6	6	6	6	6	6	Ref	6	6	6
48	65A0180/6	Spring Nut, 1/2-13 PSRS	EA	4	4	Ref	4	4	4	4	4	Ref	4	4	4	4	4	4	4	4	Ref	4	4	4
49	65A0180/5	Spring Nut, 3/8-16 (P 1008)	EA	6	6	Ref	6	6	6	6	6	Ref	6	6	6	6	6	6	6	6	Ref	6	6	6
50	60A2628	Small Cabinet, Long Unistrut	EA	Ref	Ref	Ref	Ref	Ref	Ref	Ref	Ref	Ref	Ref	Ref	Ref	Ref	Ref	Ref	Ref	Ref	Ref	Ref	Ref	Ref
51	60A2629	Small / Medium Cabinet Short Unistrut	EA	Ref	Ref	Ref	Ref	Ref	Ref	Ref	Ref	Ref	Ref	Ref	Ref	Ref	Ref	Ref	Ref	Ref	Ref	Ref	Ref	Ref
52	60A2634	Small / Medium Cabinet Unistrut Mtg. Angle	EA	Ref	Ref	Ref	Ref	Ref	Ref	Ref	Ref	Ref	Ref	Ref	Ref	Ref	Ref	Ref	Ref	Ref	Ref	Ref	Ref	Ref
53	60A2858	Small Cabinet Vertical Angle	EA	Ref	Ref	Ref	Ref	Ref	Ref	Ref	Ref	Ref	Ref	Ref	Ref	Ref	Ref	Ref	Ref	Ref	Ref	Ref	Ref	Ref

54	60A2816	TX. Mtg. Plate, 4KW URC CCR, SMR Only	EA	0	0	Ref	0	0	0	0	0	0	0	0	0	0	0	0	0	Ref	0	0	0	
55	44A6313/1	Harn Assy, L828/829 SIG. CCT Small Frame	EA	1	1	1	1	1	1	1	1	1	1	1	1	1	1	1	1	1	1	1	1	
56	44A6314/1	Harn Assy,ACE2-E, SIG. CCT Small	EA	0	0	0	1	0	1	0	0	0	1	0	1	0	1	1	0	0	0	1	0	1
57	91A0033	LABEL, L828 Danger High Voltage	EA	2	2	2	2	2	2	2	2	2	2	2	2	2	2	2	2	2	2	2	2	2
58	42B0269	LABEL, L828, Identification / Serialization	EA	1	1	1	1	1	1	1	1	1	1	1	1	1	1	1	1	1	1	1	1	1
61	94A0349/XX	Power Wiring Kit, Sig. Series Regulator	1 EA	/22 02	/22 02	/22 02	/22 01	/22 02	/22 01	/22 42	/22 42	/22 42	/22 41	/22 42	/22 41	/24 22	/22 41	/22 41	/24 82	/24 82	/24 82	/24 81	/24 82	/24 81
62	60A2859	Choke Mtg Plt 4-10KW CCT	EA	1	1	1	1	1	1	1	1	1	1	1	1	1	1	1	1	1	1	1	1	1
63	33A0055	Ferrite Core	EA	2	2	2	2	2	2	2	2	2	2	2	2	2	2	2	2	2	2	2	2	2
64	66A0015/17	#10 Flatwasher	EA	4	4	8	4	4	4	4	4	8	4	4	4	4	4	4	4	4	8	4	4	4
65	66A0026/17	#10 Split Lockwasher	EA	4	4	8	4	4	4	4	4	8	4	4	4	4	4	4	4	4	8	4	4	4
66	33A0015	Choke 7.5KW LC	EA	1	1	1	1	1	1	1	1	1	1	1	1	1	1	1	1	1	1	1	1	1
67	70A0327	PCB Ribbon Conn 26 Pin Keyed	EA	2	2	2	2	2	2	2	2	2	2	2	2	2	2	2	2	2	2	2	2	2
68	44A6478/S	Potential TX Mtg Kit, Sig Srs Regulator (SM)	EA	0	0	1	0	0	0	0	0	1	0	0	0	0	0	0	0	0	1	0	0	0
69	60A3205	Relay Mounting Bracket	EA	0	0	0	1	0	1	0	0	0	1	0	1	0	1	1	0	0	0	1	0	1

Table 10: 4, 7.5, 10 kW CCT, Configured Cores, Chokes and Power Wire Kits

Configuration Bill Of Material 4kw Cct Final Assembly			Input Voltage: Monitorin g Options:		208V INPUT						240V INPUT						400V INPUT			480V INPUT					
					L82 8 & DPM	SMI	SM R	L82 9	IR MS	L82 9 & IRM S	L82 8 & DPM	SMI	SM R	L82 9	IR MS	L82 9 & IRM S	L82 8 & DPM	SMI	SM R	L82 9	IR MS	L82 9 & IRM S			
Item No.	Part Number	Part Name/description	/X1 0X	/X1 1X	/X1 2X	/X1 3X	/X1 4X	/X1 5X	/X2 0X	/X2 1X	/X2 2X	/X2 3X	/X2 4X	/X2 5X	/X6 0X	/X6 3X	/X6 5X	/X3 0X	/X3 1X	/X3 2X	/X3 3X	/X3 4X	/X3 5X		
4	35B0462	PWR TX 4KW 6.6A 208/240V COIL	1	1	1	1	1	1	1	1	1	1	1	1	0	0	0	1	1	1	1	1	1		
4A	35B0462 /480	PWR TX4KW 6.6A 480V COIL	0	0	0	0	0	0	0	0	0	0	0	0	0	0	0	1	1	1	1	1	1		
4B	35A0753	PWR TX4KW 6.6A 400V COIL	0	0	0	0	0	0	0	0	0	0	0	0	1	1	1	0	0	0	0	0	0		
66	33A0013	Choke 4KW LC	1	1	1	1	1	1	1	1	1	1	1	1	1	1	1	1	1	1	1	1	1		
61	94A0349 /XXX	Power Wiring Kit, Sig. Series Regulator	/12 02	/12 02	/12 02	/12 01	/12 02	/12 01	/12 42	/12 42	/12 42	/12 41	/12 42	/12 41	/12 42	/12 41	/12 41	/14 82	/14 82	/14 82	/14 81	/14 82	/14 81		

**CCT (Thyristor Controlled) L-828/L-829 Constant Current Regulator
L-828/L-829 CCR (4-30 kW) Parts Ordering Codes**

Table 11: 4, 7.5, 10 kW CCT, Configured Cores, Chokes and Power Wire Kits

Configuration Bill Of Material 10kw Cct Final Assembly			Input Voltage: Monitoring Options:		208V INPUT					240V INPUT					400V INPUT			480V INPUT					
					L828 & DPM	SMI	SMR	L829	IRMS	L829 & IRMS	L828 & DPM	SMI	SMR	L829	IRMS	L829 & IRMS	L828 & 9	L829 & IRMS	L828 & DPM	SMI	SMR	L829	IRMS
Item No.	Part Number	Part Name/description	/X10X	/X11X	/X12X	/X13X	/X14X	/X15X	/X20X	/X21X	/X22X	/X23X	/X24X	/X25X	/X60X	/X63X	/X65X	/X30X	/X31X	/X32X	/X33X	/X34X	/X35X
4	35B0464	PWR TX 10KW 6.6A 208/240V COIL	1	1	1	1	1	1	1	1	1	1	1	1	0	0	0	-	-	-	-	-	-
4A	35B0464/480	PWR TX 10KW 6.6A 480V COIL	-	-	-	-	-	-	-	-	-	-	-	-	0	0	0	1	1	1	1	1	1
4B	35A0748	PWR TX 10KW 6.6A 50 HZ 400V DUAL COIL	-	-	-	-	-	-	-	-	-	-	-	-	1	1	1	-	-	-	-	-	-
66	33A0016	Choke Inductor	1	1	1	1	1	1	1	1	1	1	1	1	1	1	1	1	1	1	1	1	1
61	94A0349/XXX	Power Wiring Kit, SIG. Series Regulator	/2202	/2202	/2202	/2201	/2202	/2201	/2242	/2242	/2242	/2241	/2242	/2241	/2242	/2241	/2241	/2482	/2482	/2482	/2481	/2482	/2481

Table 12: 4, 7.5, 10 kW CCT Configured Component Plates

Configuration Bill Of Material Quantity Per Suffix (/3xxx) 3 Step Without S1 Cutout				208V INPUT					240V INPUT					480V INPUT							
				L828 & DPM	SMI	SMR	L829	IRMS	L829 & IRMS	L828 & DPM	SMI	SMR	L829	IRMS	L829 & IRMS	L828 & DPM	SMI	SMR	L829	IRMS	L829 & IRMS
Item No.	Part Number	Part Name/description	Units	/310X	/311X	/312X	/313X	/314X	/315X	/320X	/321X	/322X	/323X	/324X	/325X	/330X	/331X	/332X	/333X	/334X	/335X
19	44A6310/XXX	COM PLT 7.5 KW SIG. SRS. CCT	1 Per Suffix	/310	/311	/312	/313	/314	/315	/320	/321	/322	/323	/324	/325	/330	/331	/332	/333	/334	/335
19	44A6311/XXX	COM PLT 4KW SIG. SRS. CCT																			
19	44A6309/XXX	COM PLT 10 KW SIG. SRS. CCT																			

Table 13: 4, 7.5, 10 kW CCT Configured Component Plates

Configuration Bill Of Material Quantity Per Suffix (/4xxx) 3 Step With S1 Cutout				208V INPUT					240V INPUT					480V INPUT							
				L828 & DPM	SMI	SMR	L829	IRMS	L829 & IRMS	L828 & DPM	SMI	SMR	L829	IRMS	L829 & IRMS	L828 & DPM	SMI	SMR	L829	IRMS	L829 & IRMS
Item No.	Part Number	Part Name/description	Units	/410X	/411X	/412X	/413X	/414X	/415X	/420X	/421X	/422X	/423X	/424X	/425X	/430X	/431X	/432X	/433X	/434X	/435X
19	44A6310/XXX	COM PLT 7.5 KW SIG. SRS. CCT	1 Per Suffix	/410	/411	/412	/413	/414	/415	/420	/421	/422	/423	/424	/425	/430	/431	/432	/433	/434	/435
19	44A6311/XXX	COM PLT 4KW SIG. SRS. CCT																			
19	44A6309/XXX	COM PLT 10 KW SIG. SRS. CCT																			

Table 14: 4, 7.5, 10 kW CCT Configured Component Plates

Configuration Bill Of Material Quantity Per Suffix (/5xxx) 5 Step Without S1 Cutout				208V INPUT					240V INPUT					400V INPUT			480V INPUT							
				L8 8 & DP M	SM I	SM R	L8 29	IR MS	L8 9 & IRMS	L8 8 & DP M	SM I	SM R	L8 29	IR MS	L8 9 & IRMS	L8 28 &	L8 29	L8 9 & IRMS	L8 8 & DP M	SM I	SM R	L8 29	IR MS	L8 9 & IRMS
Item No.	Part Number	Part Name/description	Units	/51 0X	/51 1X	/51 2X	/51 3X	/51 4X	/51 5X	/52 0X	/52 1X	/52 2X	/52 3X	/52 4X	/52 5X	/56 00	/56 3A	/56 5A	/53 0X	/53 1X	/53 2X	/53 3X	/53 4X	/53 5X
19	44A6310/XXX	COM PLT 7.5 KW SIG. SRS. CCT	1 Per Suffix	/51 0	/51 1	/51 2	/51 3	/51 4	/51 5	/52 0	/52 1	/52 2	/52 3	/52 4	/52 5	/56 0	/56 3	/56 5	/53 0	/53 1	/53 2	/53 3	/53 4	/53 5
19	44A6311/XXX	COM PLT 4KW SIG. SRS. CCT																						
19	44A6309/XXX	COM PLT 10 KW SIG. SRS. CCT																						

Table 15: 4, 7.5, 10 kW CCT Configured Component Plates

Configuration Bill Of Material Quantity Per Suffix (/6xxx) 5 Step With S1 Cutout				208V INPUT					240V INPUT					400V INPUT			480V INPUT							
				L8 8 & DP M	SM I	SM R	L8 29	IR MS	L8 9 & IRMS	L8 8 & DP M	SM I	SM R	L8 29	IR MS	L8 9 & IRMS	L8 28 &	L8 29	L8 9 & IRMS	L8 8 & DP M	SM I	SM R	L8 29	IR MS	L8 9 & IRMS
Item No.	Part Number	Part Name/description	Units	/61 0X	/61 1X	/61 2X	/61 3X	/61 4X	/61 5X	/62 0X	/62 1X	/62 2X	/62 3X	/62 4X	/62 5X	/66 00	/66 3A	/66 5A	/63 0X	/63 1X	/63 2X	/63 3X	/63 4X	/63 5X
19	44A6310/XXX	COM PLT 7.5 KW SIG. SRS. CCT	1 PER SUFFIX	/61 0	/61 1	/61 2	/61 3	/61 4	/61 5	/62 0	/62 1	/62 2	/62 3	/62 4	/62 5	/66 0	/66 3	/66 5	/63 0	/63 1	/63 2	/63 3	/63 4	/63 5
19	44A6311/XX	COM PLT 4KW SIG. SRS. CCT																						
19	44A6309/XX	COM PLT 10 KW SIG. SRS. CCT																						

Figure 10: 4-10 KW Component Plate Parts (front)

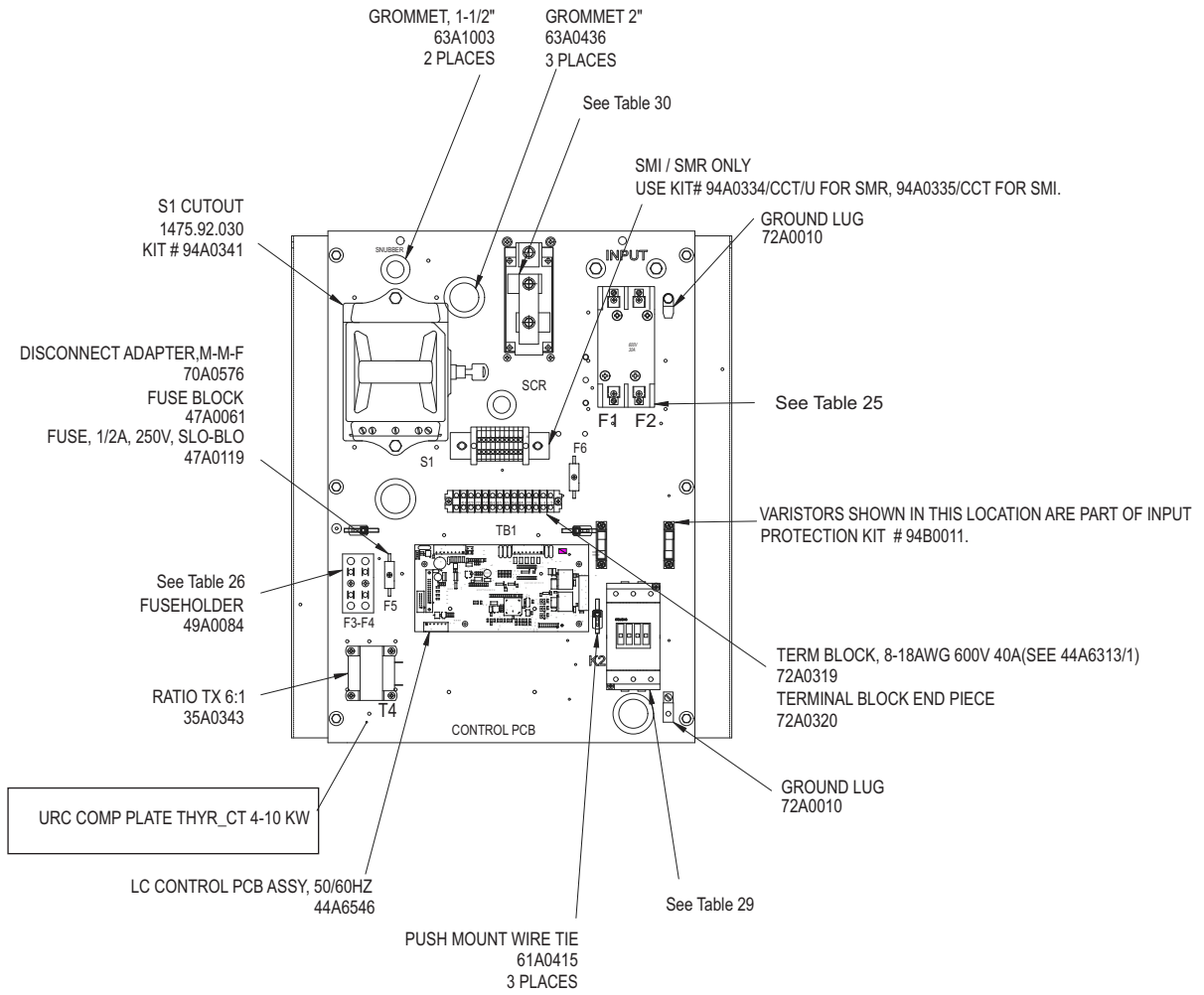
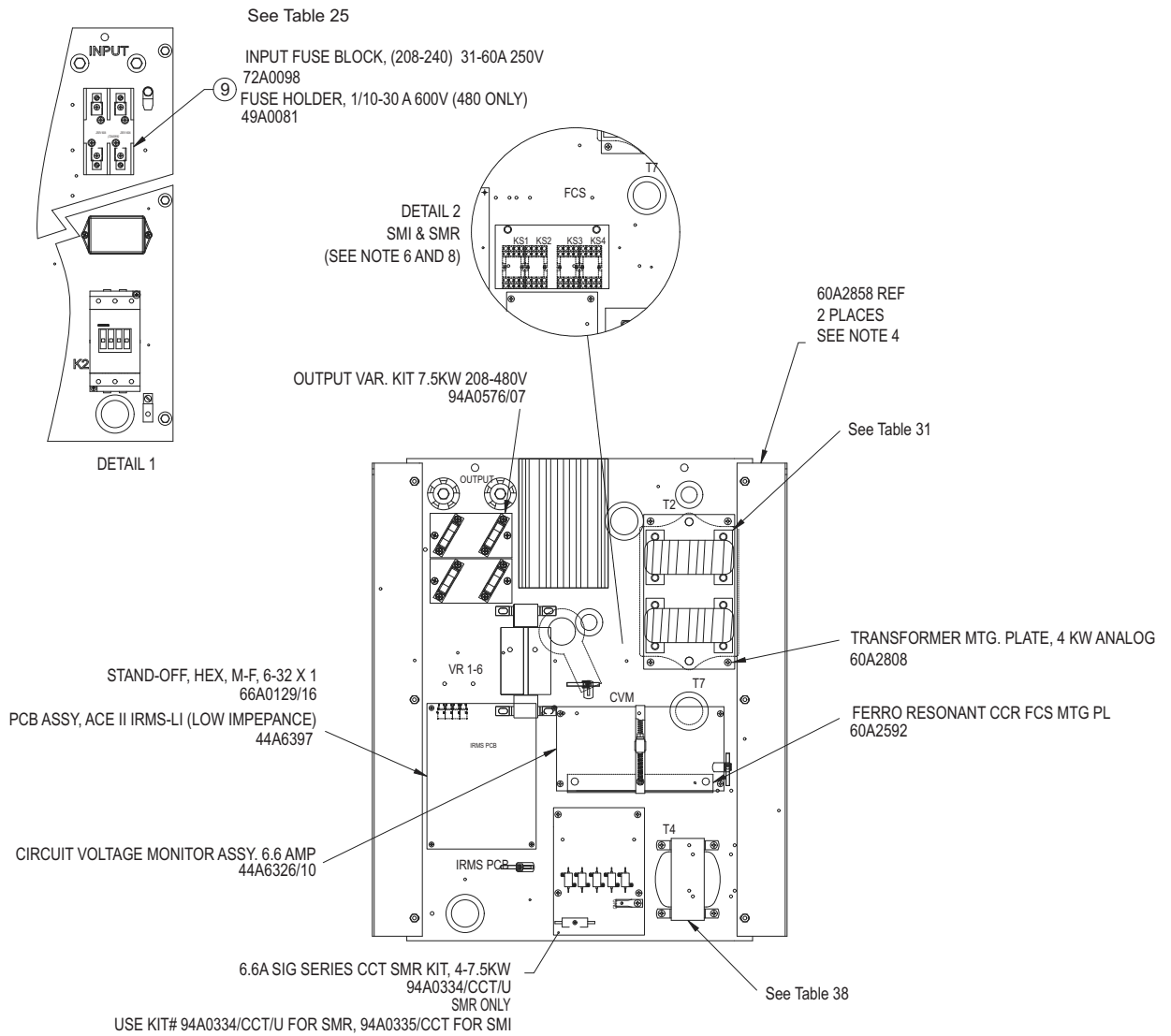

Figure 11: 4-10 KW Component Plate Parts (back)



NOTES



ADB SAFEGATE BVBA
Leuvensesteenweg 585
B-1930 Zaventem
Belgium
Tel: 32/2/722.17.11
Fax: 32/2/722.17.64
Email: info@adbsafegate.com



ADB Airfield Technologies Ltd. China
Room 901, 9F, Fang Heng Intl. Plaza
Building C, No. 6 Futong East Road,
Chaoyang District
Beijing 100102
P.R. China
Tel: +86 (10) 8476 0106
Fax: +86 (10) 8476 0090



ADB SAFEGATE Americas LLC
977 Gahanna Parkway
Columbus, OH 43230
USA
Tel: +1 (614) 861 1304
Fax: +1 (614) 864 2069
Web: www.adbsafegate.com
Email: sales.us@adbsafegate.com

<http://adbsafegate.com/contact/>



LUCEBIT GmbH
Airport Technology
Konrad-Zuse-Ring 6
D - 68163 Mannheim
Deutschland
Tel: +49 621 87 55 76-0
Fax: +49 621 87 55 76-55
Email: mail@lucebit.com



ADB SAFEGATE, Ltd.
2nd Floor, 3 Rivonia Village
Cnr Mutual Road and Rivonia Boulevard
South
Rivonia 2128
South Africa
Tel: +27 (0) 11 525 9340
Fax: +27 (0) 11 525 9348
Email: info-sa@adb-air.com



Erni AGL AG
Zürichstrasse 72
8306 Brüttsellen
Schweiz
Tel: +41 44 835 33 43
Fax: +41 44 835 33 42
Email: info@erni-agl.com



LIBERTY AIRPORT SYSTEMS Inc.
3375 North Service Road, Unit C5
Burlington, Ontario, L7N 3G2
Canada
Tel: +1 (905) 631 1597
Fax: +1 (905) 567-5312
Email: info@libertyairportsystems.com



ADB SAFEGATE BVBA
Niederlassung Deutschland
Von-der-Tann-Str. 31
90439 Nürnberg
Deutschland
Tel: +49 (0)911 2105 61 60
Fax: +49 (0)911 2105 61 61
Email: igermany@adbsafegate.com



ADB SAFEGATE Succursale France
Paris Nord 2
22 Avenue des Nations
BP 55428 Villepinte
F-95944 Roissy Charles de Gaulle
France
Tel : +33 1 49 89 66 30
Fax : +33 1 49 89 17 81
Email: france@adbsafegate.com



ADB SAFEGATE
Dubai Silicon Oasis
Wing D - Office D-309
P.O. Box 341218
United Arab Emirates
Tel: +971 4372 4970
Fax: +971 4372 4975



ADB SAFEGATE UK
Suite 4
110 High Street
Maidenhead
Berkshire
SL6 1PT
United Kingdom
Fax: +01628784865
Customer Services: +01628672906
Sales & General: +01628785339
Email: uk@adbsafegate.com



ADB SAFEGATE Italia
Via Quasimodo 46
Primo Maggio
40013 Castelmaggiore (BO)
Italia



ADB SAFEGATE Equipamentos Para
Aeroportos Ltda
Avenida Moaci n° 395
Conjunto 91
Moema CEP 04083-000
Sao Paulo-SP
Brasil
Tel: +55 (11) 5096-2169
Tel: +55 (11) 5049-2304
Email: brazil@adbsafegate.com



ADB SAFEGATE Doha
C/O Watad Group
PO Box 192
Doha, Qatar
Tel: +974 44 35 38 03
Fax: +974 44 35 44 89



ADB SAFEGATE bvba Taiwan Branch
6th floor, No. 283, Section 2 FU Hsing
South Road
Taipei 106
Taiwan R.O.C



Lucebit Hellas ΕΠΕ
25th Martiou Street 11
GR-15233 Halandri Athens
Tel: +30 210 6856 558
Fax: +30 210 6856 556
Email: mail@lucebit-hellas.com



ADB SAFEGATE



www.adbsafegate.com

Manufacturing Offices

ADB Safegate bvba
Leuvensesteenweg 585
B-1930 Zaventem
Belgium
Email: info@adbsafegate.com
Phone: +32 2 722 17 11
Fax: +32 2 722 17 64

ADB Safegate Airfield Technologies Ltd. China
Unit 603, D Block,
CAMIC International Convention Center,
No 3, Hua Jia Di East road, ChaoYang district,
Beijing 100102, P.R. China
E-mail: china@adbsafegate.com
Phone: +86 (10) 8476 0106
Fax: +86 (10) 8476 0090

ADB SAFEGATE Americas LLC
977 Gahanna Parkway
Columbus, OH 43230
USA
Tel: +1 (614) 861 1304
Fax: +1 (614) 864 2069
Web: www.adbsafegate.com
Email: sales.us@adbsafegate.com