

Technical Support:

Email: customerservice@flashtechology.com

Toll Free: 1.800.821.5825

Fax: 1.615.261.2600

Web: flashtechology.com

66363 Rev D - A650 Wireless Manual

Contents

1.0	Safety & Usage	3
1.1	Viewing Precautions	3
1.2	Battery Precautions	3
1.3	Wireless Precautions	4
1.4	Regulatory	4
1.5	Warranty Disclaimer	4
2.0	Introduction	5
2.1	Features	5
2.2	Applications	5
3.0	Installation	6
3.2	Bird Deterrent	7
3.3	Antenna	8
3.5	Location	9
3.7	Fastening	10
4.0	Operation	11
4.1	Theory of Operation	11
4.2	Modes	11
4.3	Features	13
5.0	Maintenance	17
5.1	Inspection	17
5.2	Storage & Battery Charging	17
5.3	Battery Replacement	18
5.4	Recycling	21
6.0	Troubleshooting	22
7.0	Warranty	23
8.0	Appendices	23
8.1	Glossary	23
8.2	Specifications	24

1.0 Safety & Usage

The following symbols indicate important safety warnings and precautions throughout this manual:



WARNING indicates that serious bodily harm or death may result from failure to adhere to the precautions.



CAUTION indicates that damage to equipment may result if the instructions are not followed.



NOTE suggests optimal conditions and provides additional information.



WIRELESS features and functions that require a Handheld Controller.

1.1 Viewing Precautions



Do not view an actively emitting infrared or visible light from the side of the light (close to or on beam) from a range of less than 4 ft. (1.2 m).

A safe limit for near-infrared viewing, established by the American Conference of Governmental and Industrial Hygienists (ACGIH), is 65 mW/in² (10 mW/cm²) as the maximum exposure limit for viewing for up to 16 minutes. This power density can be produced at the lens surface when actively emitting infrared light.

1.2 Battery Precautions



Use extreme caution when handling the light. This product is capable of generating enormous short-circuit currents. Remove all jewelry (bracelets, metal-strap watches, rings, etc.) before attempting to handle or remove the batteries.



Charge your battery periodically. Permanent damage and reduced capacity will result if the battery is not correctly maintained.



The lantern's Battery Pack contains lead, lead compounds, and other compounds known to the State of California to cause cancer and reproductive harm. Please handle with care and wash your hands thoroughly after handling the Battery Pack.

The rate of battery self-discharge is very dependent upon temperature. The warmer the temperature, the faster the batteries will discharge.

Lights that have been stored will usually require a top-up charge before they are put into service. The most accurate battery health status reading is obtained when the unit has been in a dark location and in off mode for at least 24 hours.

1.3 Wireless Precautions



Keep the Handheld Controller at a distance of at least 3 ft. (1 m) from the antennas of lights or other Handheld Controllers. It sends out a powerful radio signal that could damage sensitive receiver circuitry if operated at close range.

1.4 Regulatory

This device complies with Part 15 of the FCC Rules. Operation is subject to the following 2 conditions:

1. This device may not cause harmful interference, and
2. This device must accept any interference received, including interference that may cause undesired operation.

This equipment has been tested and found to comply with the limits for a Class B digital device, pursuant to Part 15 of the FCC Rules. These limits are designed to provide reasonable protection against harmful interference in a residential installation. This equipment generates, uses, and can radiate radio frequency energy and, if not installed and used in accordance with the instruction manual, may cause harmful interference to radio communications; however, there is no guarantee that interference will not occur in a particular installation. If this equipment does cause harmful interference to radio or television reception, which can be determined by turning the equipment off or on, the user is encouraged to try to correct the interference by one or more of the following measures:

- Reorient or relocate the receiving antenna;
- Increase the separation between the equipment and receiver;
- Connect the equipment into an outlet on a circuit different from that to which the receiver is connected;
- Consult the dealer or an experienced radio/TV technician for help.

This Class [B] digital apparatus complies with Canadian ICES-003.

Cet appareil numérique de la classe [B] est conforme à la norme NMB-003 du Canada.

1.5 Warranty Disclaimer



This manual will familiarize you with the features and operating standards of the product. Failure to comply with the use, storage, maintenance or installation instructions detailed in this manual could void the user warranty.

Changes or modifications not expressly approved by the party responsible for compliance could void the user's authority to operate the equipment. Installation work must be done by a qualified person(s) in accordance with all application local codes and standards.

2.0 Introduction

2.1 Features

The A650 Wireless solar airfield light has the following features:

- Self-contained, high-performance, solar-powered light source
- Wireless control range of up to 2.5 miles (4 km) with available Handheld Controller
- Easy-to-install and low-maintenance with long-life light emitting diodes (LEDs)
- Available in red, green, yellow, white and blue visible LED output colors
- Read-only Onboard User Interface (OBUI)
- Intelligent Energy Management System (EMS)
- Visible LED and night vision goggle (NVG)-compatible infrared (IR) LED outputs
- Replaceable battery pack

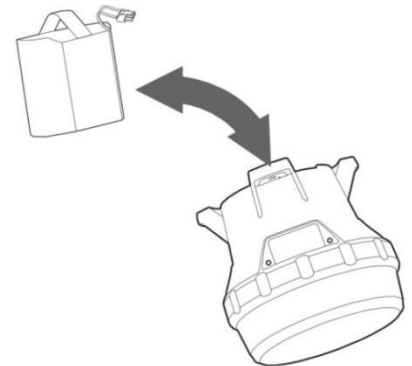
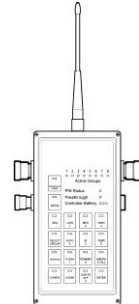

2.2 Applications

The A650 Wireless has the following applications:

- Taxiway edge
- Apron edge
- Emergency airfield
- Helipad
- Construction barricades
- Obstruction

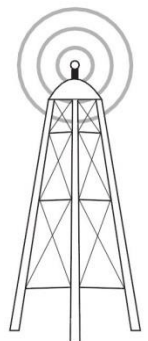
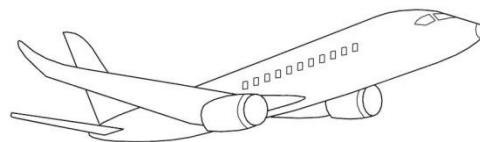

3.0 Installation

The A650 Wireless includes:

- A650 Wireless
- Antenna
- Bird deterrent
- Quick start guide

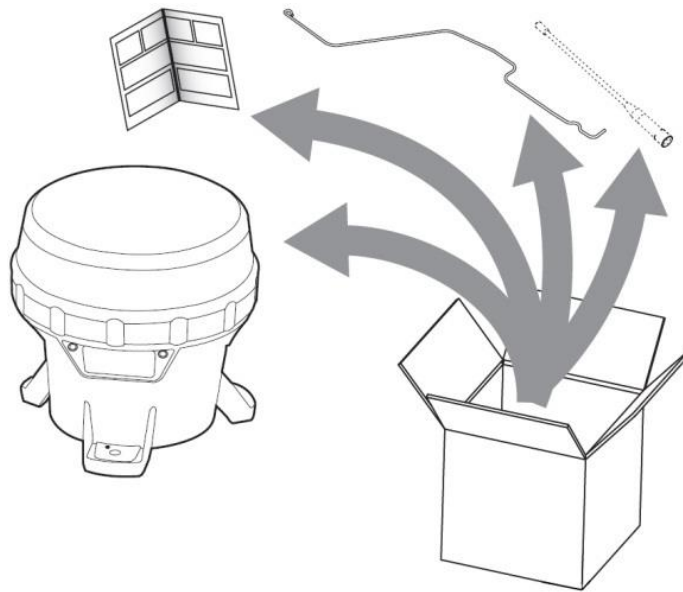

The manual (this document) is shipped independently. It is available for download from flashtechology.com.

3.2 Bird Deterrent

The A650 Wireless can have up to 2 bird deterrents. Install the deterrents before fastening the light down. Do not install a bird deterrent in the mounting foot directly below the antenna.

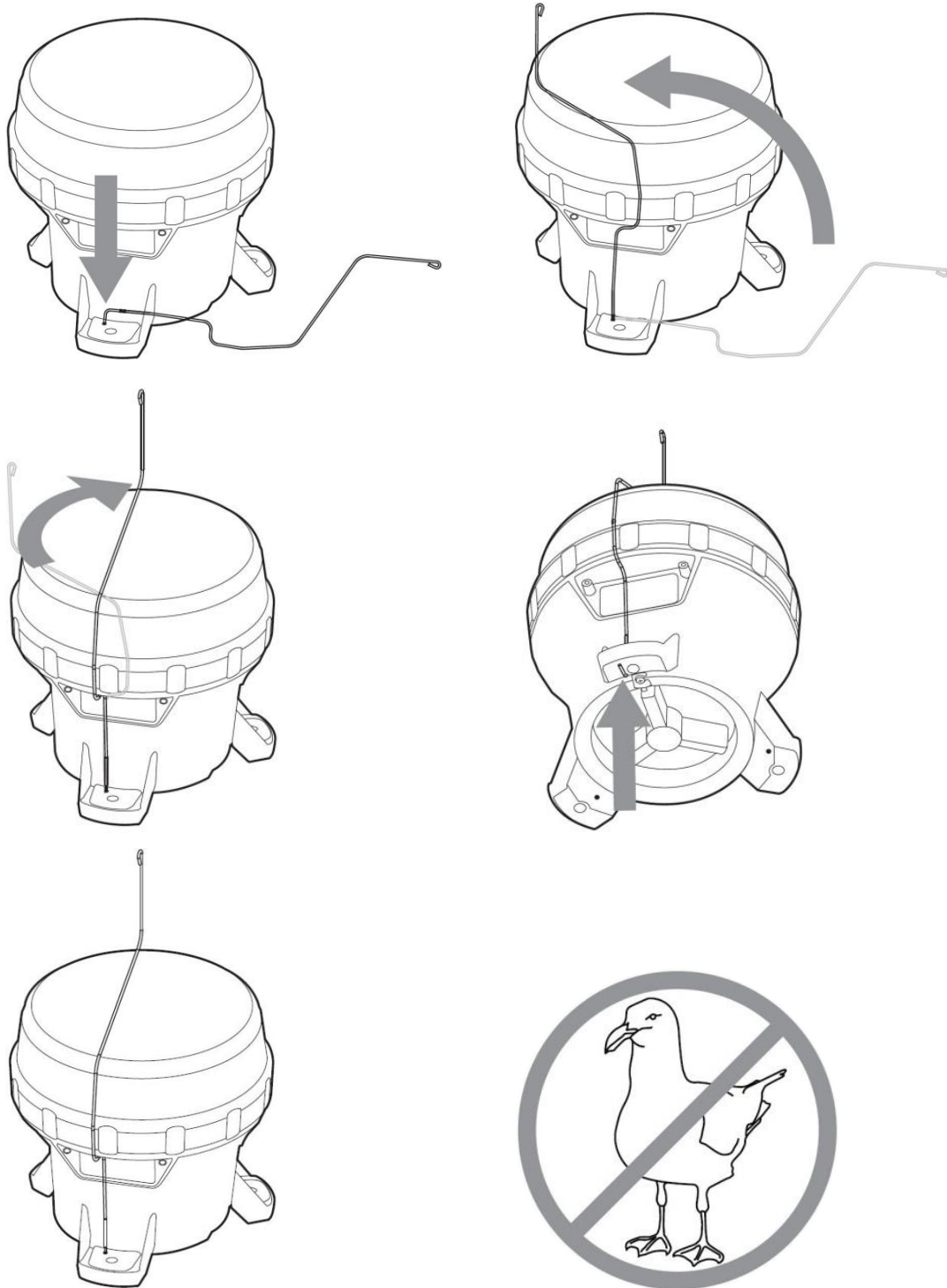

3.3 Antenna

Grip the antenna by its metal base and hand-tighten it onto the antenna connector.

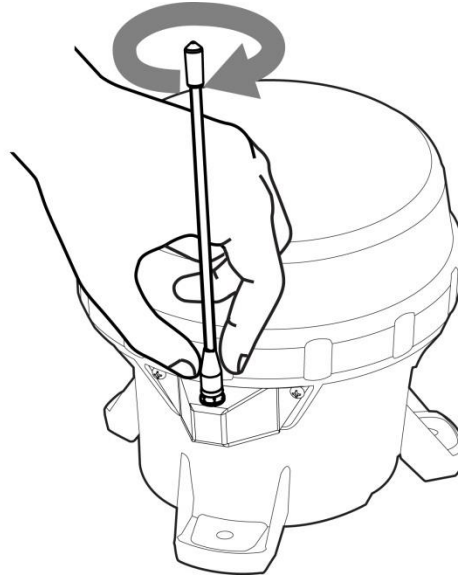

The effective range of the wireless control system is 2.5 miles (4 km). Wireless range is greatly affected by use and location. To achieve the best wireless range:

- Handheld Controller antenna is parallel to the light's antenna

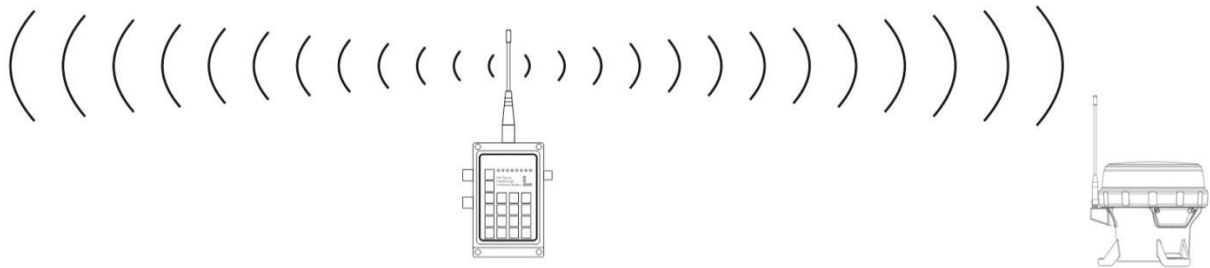

- Elevate the Handheld Controller's antenna
- Ensure surrounding grass and foliage is trim
- Clear line-of-sight between antennas

3.5 Location



Year-round, unrestricted solar exposure is critical to long-term performance. Shade dramatically reduces the ability of the light to charge its battery.

Year-round sun: During the winter, the sun is lower on the horizon. Because the angle of the sun changes with the seasons, you must be aware that obstructions such as trees, buildings, and mountains that do not shade the solar panel during the summer may shade it during the winter.

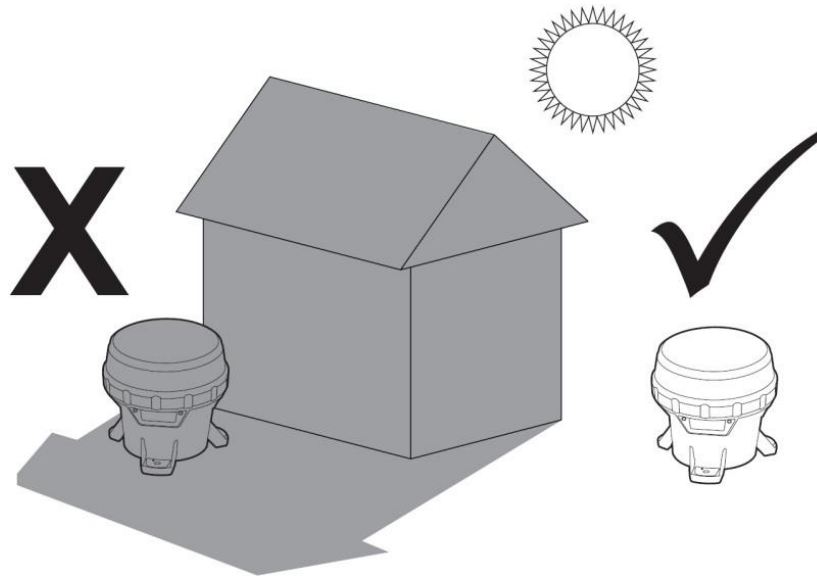

Cooler is better: The battery lasts longest if you can minimize its exposure to high temperatures. Choose a location that is away from hot, dark colored surfaces like asphalt or black steel plate. Mounting kits are available that elevate the light and can help reduce the temperature of the battery.

Flat: Ensure the mounting surface is flat and level. The surfaces in contact with the 3 mounting feet must be flat to within 0.12 in. (3 mm) of one another.

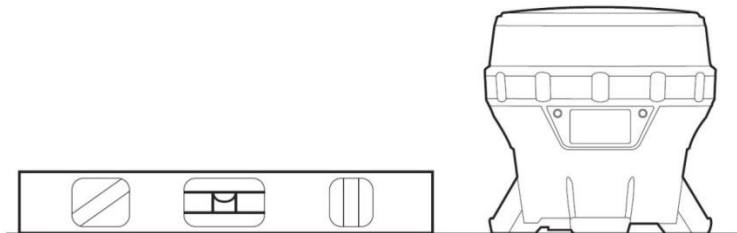

3.7 Fastening

The A650 Wireless has 3 mounting feet with holes for 0.25 in. (6 mm) fasteners. The mounting holes have a bolt circle of 5.9 in. (150 mm). Fasteners are not included but are available as kits.

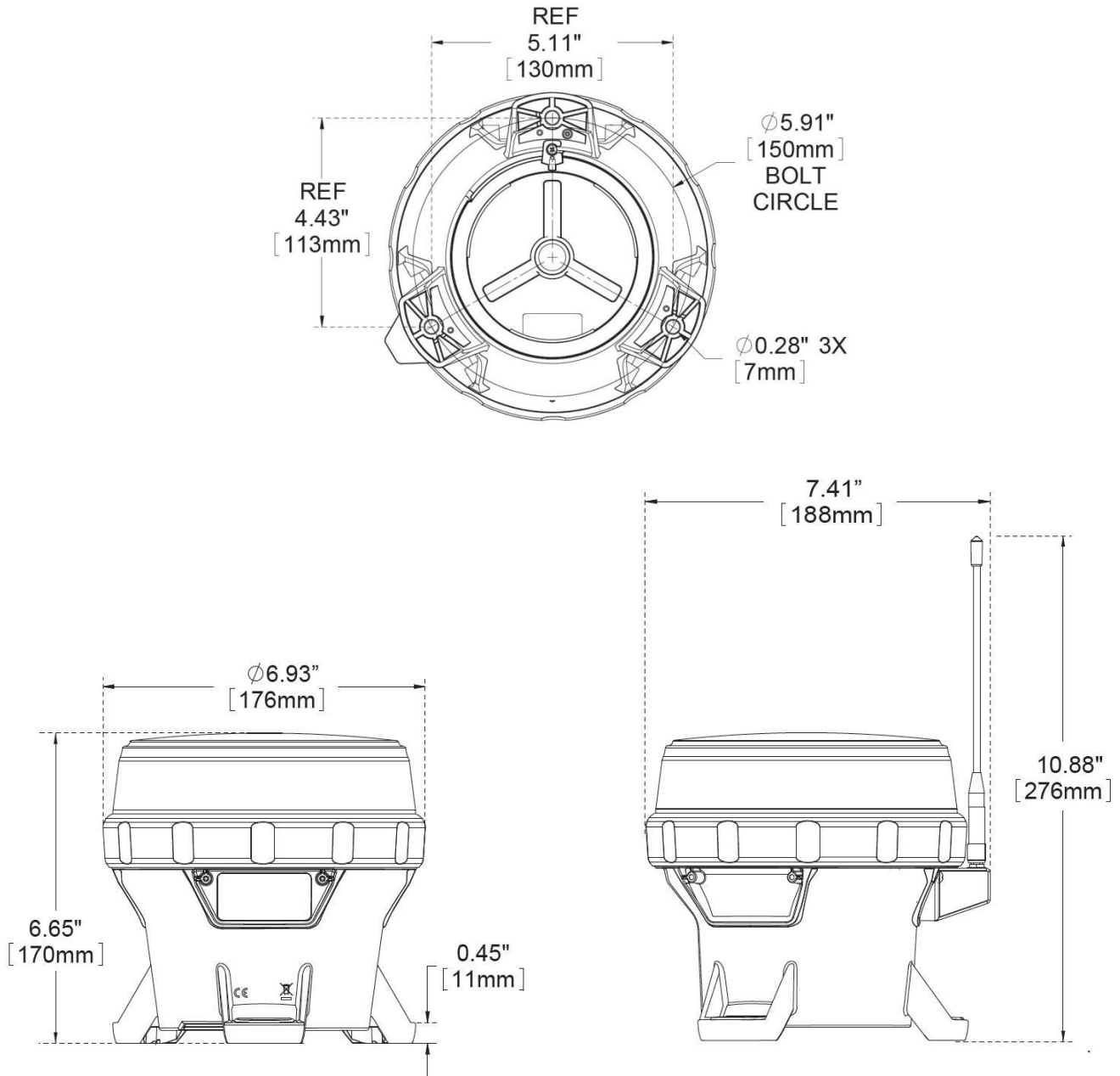

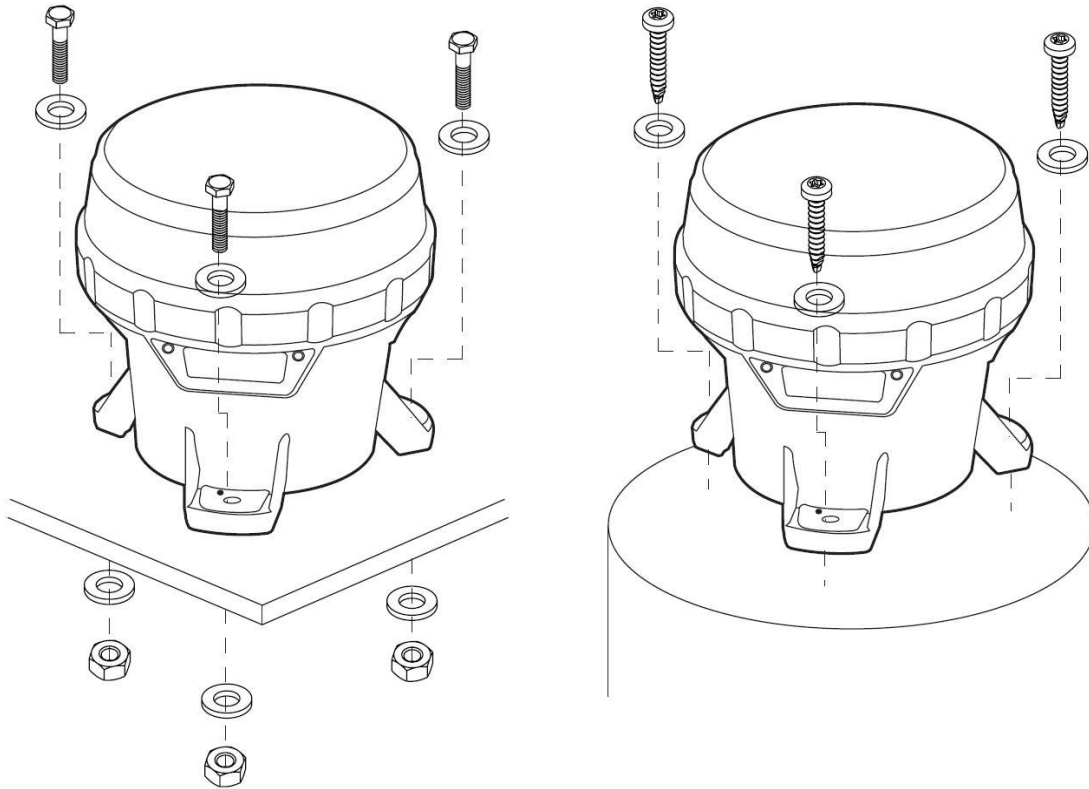

4.0 Operation

4.1 Theory of Operation

During daylight, the solar panel charges the battery using the Energy Management System (EMS). The capacity of the battery ensures that even with poor levels of sunlight over an extended period, the light has enough reserve power to continue to perform reliably.

Stored battery energy is then available to power the output LED in one of several modes. These modes are selected using the Handheld Controller. The most commonly used are Autonomous and Temporary modes.

The Handheld Controller contains a 900 MHz radio that transmits commands to a receiving radio inside the A650 Wireless. For Handheld Controller button sequences for the below modes and features, see the Handheld Controller manual.

4.2 Modes

4.2.1 Autonomous Mode (☎)

In Autonomous Mode, the output LED turns on from dusk-to-dawn and turns off during daylight. The change from dusk-to-dawn or dawn-to-dusk is known as a transition. A built-in ambient brightness sensor detects transitions.

NOTE

Autonomous Mode setting is determined by a map in the Appendices.
Correct setting is important to ensure sustainable, year-round operation.

The Autonomous Mode setting is selected via the Handheld Controller:

Setting	Intensity	Output LED	Flashing	Active
AUTO LOW	Low	Visible	No	Dusk-to-dawn
AUTO MED	Medium	Visible	No	Dusk-to-dawn
AUTO HIGH	High	Visible	No	Dusk-to-dawn
AUTO LOW IR	Low	Infrared	No	Dusk-to-dawn
AUTO MED IR	Medium	Infrared	No	Dusk-to-dawn
AUTO HIGH IR	High	Infrared	No	Dusk-to-dawn
AUTO LOW FLASH	Low	Visible	0.25 sec. on, 0.75 sec. off	Dusk-to-dawn
AUTO MED FLASH	Medium	Visible	0.25 sec. on, 0.75 sec. off	Dusk-to-dawn
AUTO HIGH FLASH	High	Visible	0.25 sec. on, 0.75 sec. off	Dusk-to-dawn
AUTO LOW IR FLASH	Low	Infrared	0.25 sec. on, 0.75 sec. off	Dusk-to-dawn
AUTO MED IR FLASH	Medium	Infrared	0.25 sec. on, 0.75 sec. off	Dusk-to-dawn
AUTO HIGH IR FLASH	High	Infrared	0.25 sec. on, 0.75 sec. off	Dusk-to-dawn

Factory default is AUTO LOW, visible LED and non-flashing.

4.2.2 Temporary Mode

In Temporary Mode, the output LED is directly controlled by the Handheld Controller. A Temporary Mode activation interrupts other modes and ignores transitions. This activation lasts for 15 min. and then the light reverts to its previous Autonomous Mode.

NOTE

Maximum number Temporary Mode activations per day is determined by a map in the Appendices.

It is possible to use more Temporary Mode activations per day. The battery will then require more than 1 day of solar energy to fully charge.

The Temporary Mode setting is selected via the Handheld Controller:

Setting	Intensity	Output LED	Flashing	Active
TEMP LOW	Low	Visible	No	15 min.
TEMP MED	Medium	Visible	No	15 min.
TEMP HIGH	High	Visible	No	15 min.

Setting	Intensity	Output LED	Flashing	Active
TEMP LOW IR	Low	Infrared	No	15 min.
TEMP MED IR	Medium	Infrared	No	15 min.
TEMP HIGH IR	High	Infrared	No	15 min.
TEMP LOW FLASH	Low	Visible	0.25 sec. on, 0.75 sec. off	15 min.
TEMP MED FLASH	Medium	Visible	0.25 sec. on, 0.75 sec. off	15 min.
TEMP HIGH FLASH	High	Visible	0.25 sec. on, 0.75 sec. off	15 min.
TEMP LOW IR FLASH	Low	Infrared	0.25 sec. on, 0.75 sec. off	15 min.
TEMP MED IR FLASH	Medium	Infrared	0.25 sec. on, 0.75 sec. off	15 min.
TEMP HIGH IR FLASH	High	Infrared	0.25 sec. on, 0.75 sec. off	15 min.

4.2.3 Standby Mode

Standby Mode turns off the output LED and waits for the next transition. After a transition, the light enters its previous Autonomous Mode.

4.2.4 Lights Off Mode

Lights Off Mode turns off the output LED indefinitely until it receives a command to turn them on. Lights Off Mode is entered via the Handheld Controller and is different than sliding the switch to OFF.

4.2.5 Emergency Mode

Emergency Mode sets all lights in all groups to emergency flash. Emergency flash is TEMP HIGH FLASH. After 15 min., the lights revert to their previous Autonomous modes.

4.2.6 ARCAL Mode

The Aircraft Radio Control of Aerodrome Lighting (ARCAL) feature works in conjunction with an ARCAL VHF receiver to allow aircraft pilots to control the airfield lights.

4.3 Features

4.3.1 On-Board User Interface

The On-Board User Interface (OBUI) is viewable through the bottom cover. Slide the switch ON or press a button on the OBUI to turn on the display.

The OBUI has no user editable parameters and provides read-only feedback:

What is the battery's state of charge?	<i>bAtt</i>	<i>Good</i>	Good, deploy the light
		<i>Chrg</i>	Charge the battery before deploying
		<i>Lo</i>	LVD is entered; charge the battery before deploying
		<i>Bad</i>	Bad battery needs replacing
Is the wireless system on?	<i>rF</i>	<i>on</i>	Ready to receive wireless commands
		<i>off</i>	Will not receive wireless commands
		<i>Err</i>	Radio failure
Are the infrared output LEDs on?	<i>Ir</i>	<i>on</i> <i>off</i>	
What group ID is the light part of?	<i>gPI d</i>	<i>1 2 3 4 5 6 7 8</i>	
Is Universal Code Sequence on?	<i>UCS</i>	<i>on</i> <i>off</i>	
System version?	<i>InfO</i>	<i>0.0.0.0</i>	

4.3.2 Switch

The switch must be ON (**I**) to respond to Handheld Controller commands:

- Light enters its last mode

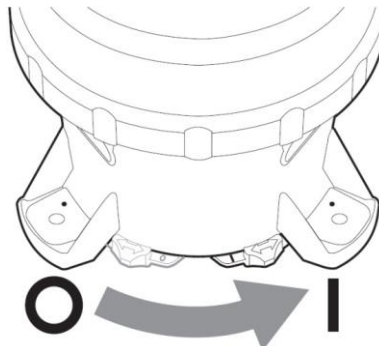

Switch the light OFF (**O**) to ship or store it:

- Will not respond to wireless control and will not be able to turn on its output LEDs
- Stores the last mode
- Sunlight will continue to charge the battery
- Does not turn itself off after 24 hours of darkness

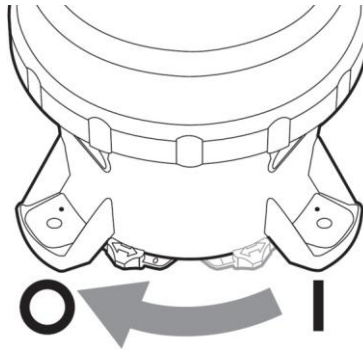

4.3.3 Automatic Light Control

Automatic Light Control (ALC) is a patented algorithm that matches the light's energy consumption to its energy storage. As the battery state of charge diminishes, ALC decreases the output LED intensity. ALC has 9 intensity steps until finally entering LVD. The ALC step depends on the battery state of charge. This ensures the light will continue to operate through periods of poor sunlight.

ALC is enabled in all Autonomous Modes.

ALC is disabled in all Temporary Modes.

4.3.4 Low Voltage Disconnect

Low Voltage Disconnect (LVD) protects the battery from being discharged to levels low enough to cause permanent damage. When LVD is entered:

- Radio and output LED are disabled
- Output LED flashes 0.1 sec. every 60 sec. to let the user know the light needs attention
- Battery continues charging
- When the battery state of charge reaches an acceptable level, LVD is exited.

LVD is enabled in all Modes.

4.3.5 Diagnose

The battery state of charge and radio health can be queried via the Handheld Controller using its Diagnose function.

Diagnose is disabled when LVD is entered.

4.3.6 Grouping

Grouping allows independent control of different subsets of lights on an airfield:

- There are 8 groups, numbered 1 through 8
- Each light can be assigned to only one group
- Handheld controller can control multiple groups at a time
- A light can be reassigned to another group as required
- When adding a light to a group, the Handheld Controller re-sends the last mode to everyone in that group

In order to configure the group of a light:

1. Light must be ON for at least 10 sec., then slide the switch OFF and then ON within 10 sec.
2. This quick ON-OFF-ON instructs the light to receive grouping configurations from the Handheld Controller for 5 min.
3. Grouping configuration is sent from Handheld Controller
4. After successfully receiving a grouping configuration, the light flashes for 7 sec.

Factory default is group 1.

4.3.7 Unique Code Sequence

Unique Code Sequence (UCS) allows one or more Handheld Controllers to be uniquely associated to one or more lights. When UCS is enabled, the Handheld Controller sends a code with each radio transmission. Only lights configured to accept that particular code will respond to the transmission. The benefits are:

- Independence nearby installations of lights can be operated independently by different Handheld Controllers without interference
- Security it is not possible for another Handheld Controller to interrupt airfield operation

The Handheld Controller cannot control UCS configured and non-UCS configured lights at the same time.

For security, the user has to manually interact with the light for UCS configuration:

1. Light must be ON for at least 10 sec., then slide the switch OFF and then ON within 10 sec.
2. This quick ON-OFF-ON instructs the light to receive UCS configurations from the Handheld Controller for 5 min.
3. UCS configuration is sent from Handheld Controller
4. After successfully receiving a UCS configuration, the light flashes for 7 sec.

Factory default is UCS disabled.

4.3.8 Factory Reset

Factory Reset sets the light back to a known state:

- AUTO LOW visible LED, non-flashing
- Group 1
- UCS off

To perform a Factory Reset:

- Remove bottom cover
- Press & hold SET for 2 sec.
- OBUI displays *FAct rSEt*

5.0 Maintenance

5.1 Inspection

Although the A650 Wireless is maintenance-free, significant performance gains can be made with clean solar panels and lenses:

- Clean the solar panels monthly. Use water and a soft sponge or cloth. A mild non-abrasive cleanser can be used for more stubborn residue. Rinse well.
- Clean solar panels and lenses more frequently during drier months, as they may become covered in dust more quickly. A pressure washer is not recommended.
- Visual inspection – check the exterior for cracks, missing or broken hardware or other potential problems.

5.2 Storage & Battery Charging

When storing the light, it is important to maintain the battery:

- Switch the light OFF or disconnect the battery
- Store in a cool location
- Check the battery state of charge every 1 month

NOTE

Do not use the Lights Off Mode for storing the light.

The radio is still active in this mode and may receive wireless commands.

If the OBUI indicates *bAtt cHr9* or *bAtt Lo*, the battery requires charging. Charge the battery fully until the OBUI indicates *bAtt Good*. The battery can be charged by placing the light in sunlight or under an incandescent light bulb.

The battery may also be charged using the available alternating current (AC) plug-in battery charger:

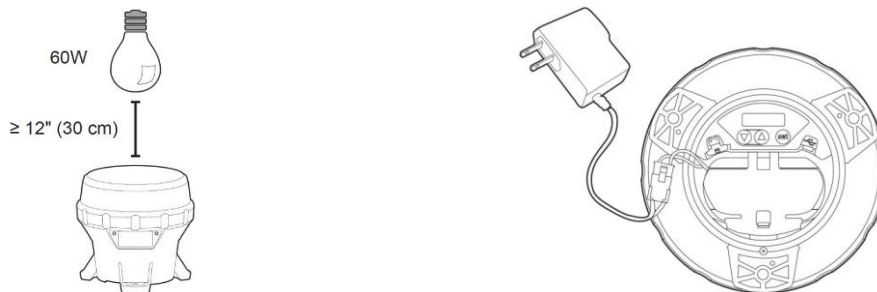



5.3 Battery Replacement

If the OBUI indicates *bAtt bAd*, the battery state of charge is bad. The battery is permanently damaged and needs to be replaced:

1. Turn the light upside down on a soft surface to avoid scratching

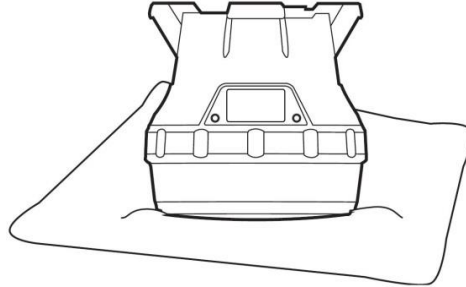

2. Turn the locking screw counterclockwise to allow the locking tab to clear. Do not completely remove the locking screw

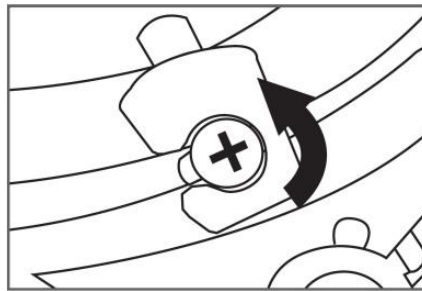

3. Turn the bottom cover counterclockwise until it stops. An available bottom cover tool assists in the rotation and insertion of the bottom cover.

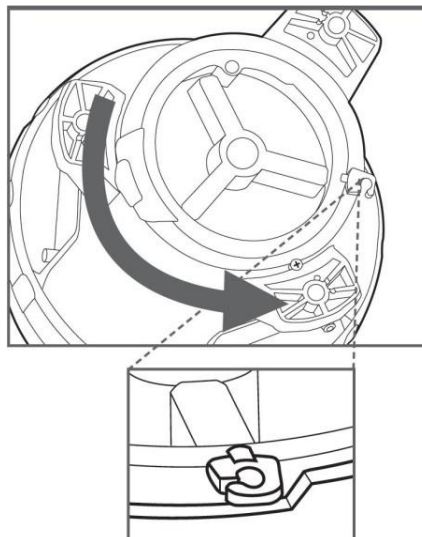

4. Push up on the locking tab to lift the bottom cover out.

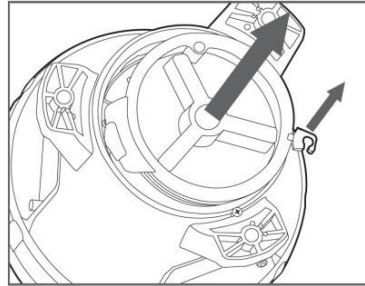

5. Press down on the connector latch and gently pull on the connector body to disconnect. Do not pull by the wires.

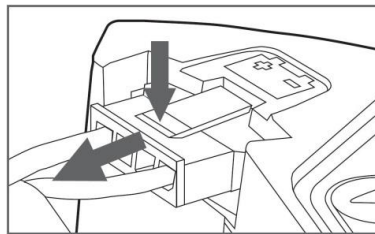

6. Unhook the battery strap from the tab and pull up on the battery strap

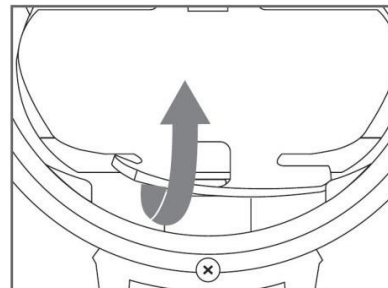
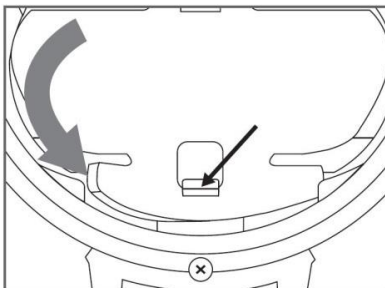

7. Stretch the battery strap out of the way and pull the battery out by its ribbon, being careful not to damage any wires

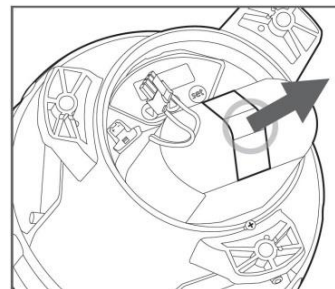
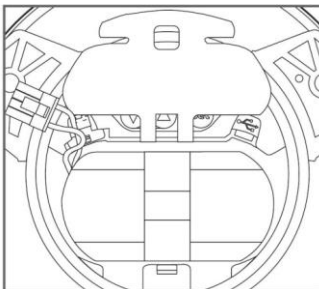

Installing a battery is similar to the above steps:

1. Stretch the battery strap out of the way and gently insert battery
2. Pull the battery strap over the battery and hook onto the tab
3. a) For a used battery, plug in the battery connector.

- b) For a new battery, hold down the SET button and plug in the battery connector. Continue to hold SET until **Zero** is displayed and then release. This resets the battery health monitor so that the light knows this is a new battery.
- 4. Ensure the bottom cover o-rings and the inside surfaces of the light are clean.

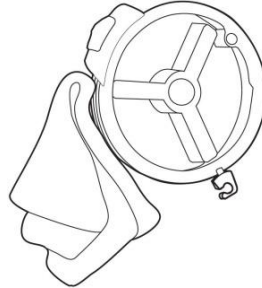

- 5. If the bottom cover was difficult to remove, apply a thin coat of silicone o-ring lubricant to the o-rings before installation.
- 6. Align the bottom cover locking tab with the small angled wall in the chassis

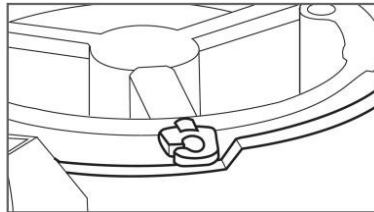

- 7. Turn the bottom cover clockwise while pressing down. Turn until the locking tab aligns with the locking screw. An available bottom cover tool assists in the rotation and insertion of the bottom cover.

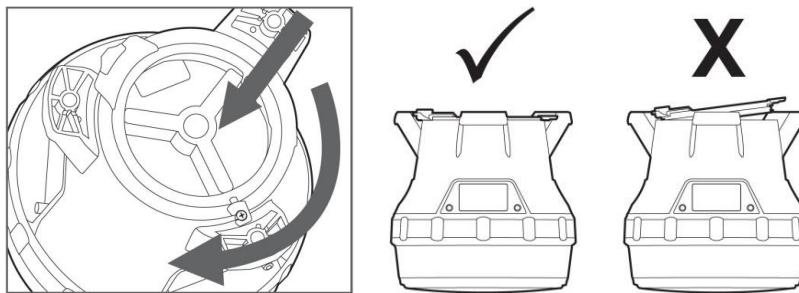

- 8. Turn the locking screw clockwise to lock the bottom cover in the installed position.

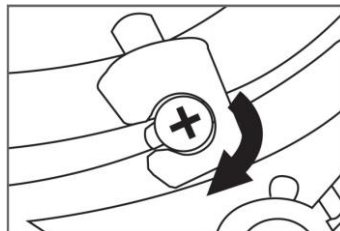

5.4 Recycling

This product required the extraction and use of natural resources. It may contain substances that could be harmful to the environment or human health if improperly handled at the product's end of life. In order to avoid release of such substances into the environment and to reduce the use of natural resources, we encourage you to recycle the product in an appropriate way that will ensure most of the materials are reused or recycled appropriately. Check your local municipality for electronics recyclers.



The symbol indicates that this product complies with the European Union's requirements according to Directive 2002/96/EC on waste electrical and electronic equipment (WEEE).



The battery is a rechargeable lead-acid AGM battery. Consult your local laws for information on recycling.

6.0 Troubleshooting

Symptom	Cause	Solution
Output LED is off and unresponsive to wireless control	LVD is entered	Charge the battery
	Battery is bad	Replace the battery
	Battery is not connected	Check that the battery connector is fully inserted
	Switch is OFF	Slide switch to ON
	Mismatched groups	Ensure the Handheld Controller's and light's group match
	Infrared LEDs are on	De-select the IR button on the Handheld Controller; send a visible output command
	UCS is enabled	Ensure the Handheld Controller's and light's UCS match or turn off UCS
	Radio failure	Call Customer Service
Output LED is off in Autonomous Mode	Daylight; ambient brightness is above 500 lux	Darken the entire light and wait 20 sec. for the light to turn on
	Nearby lights are illuminating the ambient brightness sensor	Increase distance between lights, turn off unneeded lights, or shield lights
Output LED is on, but unresponsive to wireless control	Antenna not installed	Ensure the light's antenna is properly installed
	Handheld Controller problem	Check Handheld Controller battery, PIN status, and Passthrough
	Mismatched groups	Ensure the Handheld Controller's and light's group match
	UCS is enabled	Ensure the Handheld Controller's and light's UCS match or disable UCS
	Radio failure	Call Customer Service
Output LED flashes once every minute.	LVD is entered	Charge the battery
	Battery is bad	Replace the battery

7.0 Warranty

This product is covered by the Flash Technology warranty. Visit flashtechnology.com for additional information.

Before contacting Flash Technology's customer service department, please have the serial number of your light available, a brief description of the problem, as well as all details of the installation and recharging efforts.

To contact Customer Service:

Mail: Flash Technology
332 Nichol Mill Lane
Franklin, TN 37067 USA

Phone: 1.800.821.5825 (toll-free)

Fax: 1.615.261.2600

Email: customerservice@flashtechnology.com

Website: flashtechnology.com

8.0 Appendices

8.1 Glossary

AC	Alternating Current
ACGIH	American Conference of Governmental and Industrial Hygienists
AGM	Absorbed Glass Matt
ALC	Automatic Light Control
ARCAL	Aircraft Radio Control of Aerodrome Lighting
DC	Direct Current
EMS	Energy Management System
FAA	Federal Aviation Administration
FCC	Federal Communications Commission
ICAO	International Civil Aviation Organization
ICES	Industry Canada Equipment Standard
IR	Infrared
ISM	Industrial, Scientific and Medical
LED	Light Emitting Diode

LVD	Low Voltage Disconnect
NVG	Night Vision Goggle
OBUI	On-Board User Interface
RoHS	Restriction on Hazardous Substances
UCS	Universal Code Sequence
WEEE	Waste Electrical and Electronic Equipment

8.2 Specifications

Physical	
Mounting	5.91 in. (150 mm) 3-hole bolting circle 0.25 in. (6 mm) hardware Over-torque resistant
Chassis	Polycarbonate / polysiloxane alloy Double o-ring sealing Waterproof, vented battery compartment
Height	10.9 in. (276 mm)
Width	7.4 in. (188 mm)
Weight	3.5 lb. (1.6 kg)
Operating Temperature	-45 to 124 °F (-43 to 51 °C) ambient -45 to 190 °F (-43 to 88 °C) internal
Storage Temperature	-45 to 176 °F (-43 to 80 °C) ambient
Optical	
Light Source	High-power visible LED Infrared LEDs, NVG-compatible
Intensity	See plots in Appendices
Chromaticity	Visible: ICAO and FAA (SAE 25050) blue, red, white, yellow, and red Infrared: 870 – 890 nm peak wavelength
Flash Pattern	0.25 sec. on, 0.75 sec. off

Ambient Light Sensing	445 – 505 lux
Automatic Light Control (ALC)	Yes, ALC will reduce output intensity in response to unusually low amounts of sunlight to ensure continued operation
Color Indicator	Yes, FAA Eng. Brief 67 compliant

Energy Collection	
Control	Intelligent, microprocessor Energy Management System (EMS)
Solar Panel	High-efficiency cells w/ bypass diodes Blocking diode function
Air Gap between Solar Panel and Lens	No, an air gap is undesirable because it refracts sunlight and decreases the amount of solar energy collected
Battery Charger	Maximum Power Point Tracking (MPPT) collects the most energy under all sunlight conditions Temperature-compensated Reverse polarity protection
Battery	Pure lead, valve-regulated lead-acid (VRLA) Absorbed glass mat (AGM) w/ metal case Tool-less replacement Recyclable
User Interface	
On-board User Interface	Yes, LED display Battery state of charge, wireless, infrared, group, UCS, info.
Datalogger	Yes
Battery State of Health	Yes
Ability to Connect to Computer	Yes, mini-USB
Wireless Control	
Radio	902 – 928 MHz FHSS Up to 2.5 miles (4 km) range Replaceable antenna
Light Control	Visible, infrared, steady-on, and flashing settings

	Autonomous, Temporary, Standby, Lights Off, and Emergency Modes
Diagnostics	Yes
Grouping	Yes, up to 8
Universal Code Sequence (UCS)	Yes
ARCAL Control	Yes

Standards and Testing	
ICAO Photometrics	Annex 14, 5 th Ed. 2009 blue taxiway edge
FAA Photometrics	AC 150/5345-46C L-861T blue taxiway edge AC 150/5345-50B L-863 blue, yellow, green, red portable AC 150/5345-46C L-860E red-red AC 150/5370-2E Barricades & construction
Vibration	UL 1104 Part 23 EN 60945, Part 8.7 Vibration, 3 – 60 Hz MIL-STD-202G, Method 201A, 10 – 55 Hz MIL-STD-202G, Method 204, Test Condition B, 10 – 55 Hz
Shock	UL 1104 Part 27.4 EN 60945 Part 8.6 Drop MIL-STD-202G, Method 213B, Test Condition G MIL-STD-202G, Method 213B, Test Condition H MIL-STD-810F, Method 516.5, Procedure IV
Wind Loading	400 mph (179 m/s)
Ingress	EN 60529, IP 66 MIL-STD-202G, Method 104A, Test Condition B
Salt Fog	MIL-STD-810G, Method 509.4 ASTM B117-73 (1979)
Chemical Resistance	MIL-STD-810G, Method 504, Procedure II
Electrostatic Discharge (ESD)	EN 61547 EN 61000-4-2 up to ± 16 kV air and contact discharge FAA-STD-019E compliant for ESD

Standards and Testing	
Electromagnetic Interference (EMI) & Electromagnetic Compatibility (EMC)	FCC Part 15 emissions & immunity ICES-003 emissions & immunity EN 61000-6-3 emissions EN 61000-6-4 emissions EN 61000-6-2 immunity EN 61000-4-3 immunity
Mounting Fastener Over-torque	Tested to withstand up to 65 ft.-lb. (88 N-m)
LED Lumen Maintenance	IES LM-80
Battery Life	IEC 61427
Humidity / Damp Heat	MIL-STD-810G, Method 507.5 MIL-STD-202G
Solar Radiation	MIL-STD-810G, Method 505.5, Procedure II, climate cycle A2
RoHS	Yes
Patents	US 5 782 552, 6 013 985, 6 573 659 and other US and international patents apply