

AWL
AIRCRAFT WARNING LIGHT

MIOL-B & LIOL-B
TYPE

OPERATION AND
MAINTENANCE MANUAL

LUXSOLAR - AERONAUTICAL LIGHTING

INDEX:

1. MIOL-B Datasheet, ordering code, weight and dimensions
2. LIOL-B Datasheet, ordering code, weight and dimensions
3. Overview
4. ICAO rules general concepts, type of lamps
5. MIOL lamps light emission tests
6. LIOL lamps light emission tests
7. Safety notice
8. Typical general layout and system description
9. Fixing details
10. AWL systems operation
11. Fault detection, electronic boards details and setting
12. Maintenance
13. Troubleshooting
14. MIOL-B tests: ICAO certification, IP65 test, Vibration test, Climatic test report.
15. LIOL-B tests: ICAO certification, IP65 test, Climatic test report.
16. Warranty

LUXSOLAR - AERONAUTICAL LIGHTING

1) MIOL-B DATASHEET

AIRCRAFT WARNING LIGHTS

MEDIUM INTENSITY OBSTRUCTION LIGHT MIOL - B / MIOL - C



AWL - MIOL - B/C



rev_01

COMBUSTION AND ENERGY - info@luxsolar.com - www.luxsolar.com - Ph. +39.0341.260926



LUXSOLAR - AERONAUTICAL LIGHTING

AIRCRAFT WARNING LIGHTS

MIOL - B / MIOL - C

AWL - MIOL - B/C

KEY FEATURES

- Based on LED technology
- 2.000 cd night mode, RED flashing for MIOL-B
- 2.000 cd night mode, RED steady burning for MIOL-C
- Long life time >10+ years life expectancy
- Low consumption
- Stabilised light output
- Lightweight and compact
- Low wind load factor
- Alarm/remote status control
- Easy to install
- No RF-radiations
- Light output alignment device
- Patented beacon (EU 001929910-0001; Canada 145 189; USA D673.474)

OPTICAL FEATURES

- Cd emission @ -0,5° and +4°
- Horizontal beam radiation 360°
- Vertical beam spread 4°
- PMMA lens

OPTIONS

- Twin version: two galvanically separated circuits in the same fixture
- Anti bird protection
- Beacon support bracket
- Power supply AC or DC
- GPS (Global Position System) syncro
- Infrared available

ELECTRICAL FEATURES

- Average power consumption for MIOL-B (@20fpm): 9W
- Average power consumption for MIOL-B (@40fpm): 12W
- Average power consumption for MIOL-B (@60fpm): 15W
- Average power consumption for MIOL-C (steady burning) : 54W
- LED feeded at constant current
- Lightning protection

MECHANICAL FEATURES

- Anodised aluminium body with heat-sink for natural draft air cooling
- RAL7035 painted aluminium body lamp
- Bottom wind collector for central heat-sink cooling
- Borosilicate glass cover protection
- Silicon gasket
- Degree of protection: IP66
- Operating temperature: -45°C to +55°C
- Storage temp. range: -45°C to +55°C
- Lamp unit weight: 3,5kg

APPLY TO

- Airport - Stack - High building - Chimney - Tower crane
- Pipe line - Bridge - Radio and television tower
- Transmission line - Wind turbine - Wind mast measurement
- Radar - Antenna

INTERNATIONAL REGULATION

- ICAO Aerodromes -Annex 14 Volume 1, 6th Edition, July 2013 Chapter 6: Medium intensity, Type B flashing obstacle light MIOL-B type or Type C steady burning obstacle light MIOL-C type
- FAA AC150/5345-43F E.B. #67 Lamp type L-864 or Twin L-864
- DGAC/STAC approval nr. 2013A037
- CE marking



info@luxsolar.com - www.luxsolar.com - Ph. +39.0341.260926 - COMBUSTION AND ENERGY

Document is subject to change without any notice

rev_01



COMBUSTION AND ENERGY SRL

Via per Dolzago 21, 23848 - Oggiono (LC) - Italy - Ph. +39 0341.260926 - E-mail: info@luxsolar.com / info@ce2k.com - Web: www.luxsolar.com / www.ce2k.com
LXS and LUXSOLAR are trademarks of Combustion and Energy Srl

Page. 4 of 48 - rev 2.00

LUXSOLAR - AERONAUTICAL LIGHTING

AIRCRAFT WARNING LIGHTS

MIOL - B / MIOL - C

Order code

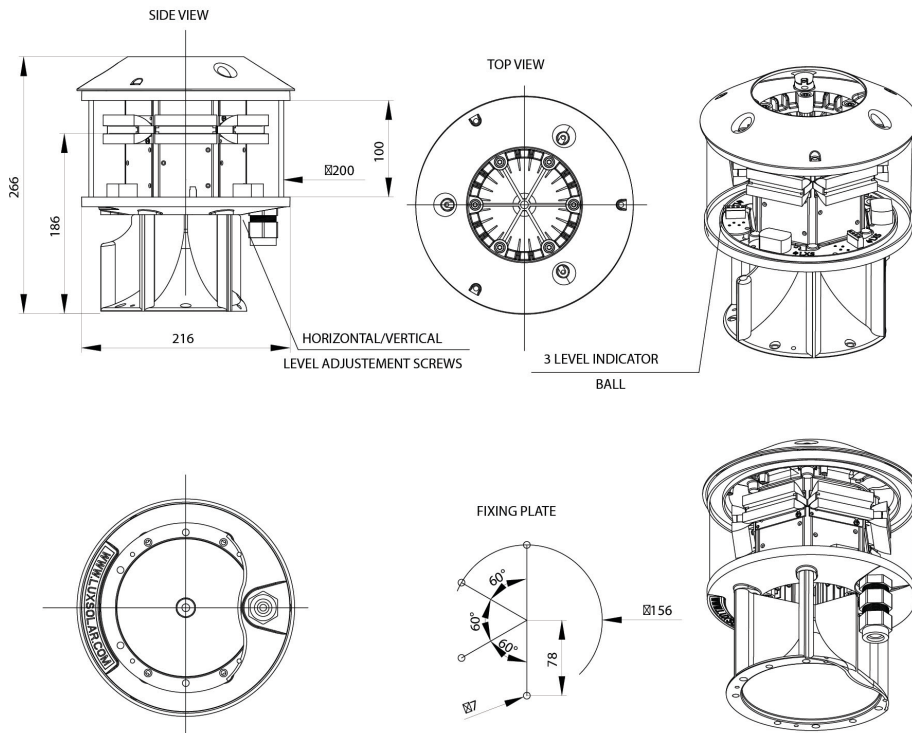
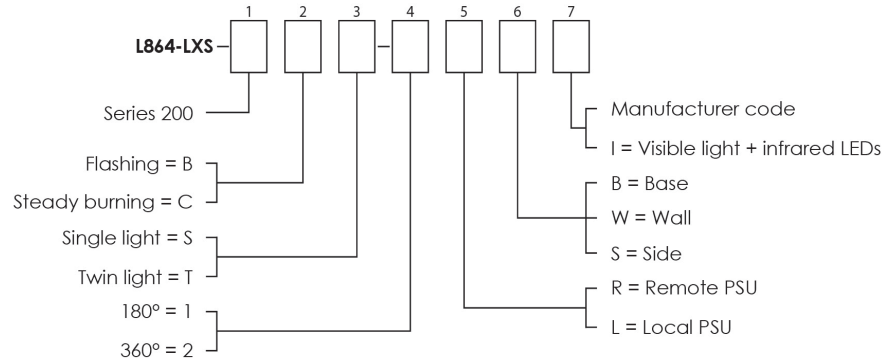

AWL - MIOL - B/C

rev_01

COMBUSTION AND ENERGY - info@luxsolar.com - www.luxsolar.com - Ph. +39.0341.260926



COMBUSTION AND ENERGY SRL

Via per Dolzago 21, 23848 - Oggiono (LC) - Italy - Ph. +39 0341.260926 - E-mail: info@luxsolar.com / info@ce2k.com - Web: www.luxsolar.com / www.ce2k.com
LXS and LUXSOLAR are trademarks of Combustion and Energy Srl

Page. 5 of 48 - rev 2.00

LUXSOLAR - AERONAUTICAL LIGHTING

2) LIOL-B DATASHEET

AIRCRAFT WARNING LIGHTS

LOW INTENSITY OBSTRUCTION LIGHT LIOL - A / LIOL - B



AWL - LIOL



rev_01

COMBUSTION AND ENERGY - info@luxsolar.com - www.luxsolar.com - Ph. +39.0341.260926



LUXSOLAR - AERONAUTICAL LIGHTING

AIRCRAFT WARNING LIGHTS

LIOL - A / LIOL - B

KEY FEATURES

- Based on LED technology
- RED steady burning light
- >10 cd LIOL - A
- >32 cd LIOL - B
- Long life time >10+ years life expectancy
- Low consumption
- Stabilised light output
- Lightweight and compact
- Low wind load factor
- Easy to install
- No RF-radiations
- Patented beacon
(Germany 20 2011 107 787.3;
France 1160162)

OPTICAL FEATURES

- Cd emission +6° and +10°
- Horizontal beam radiation 360°
- Vertical beam spread >10°
- Optical reflector

OPTIONS

- Twin version: two galvanically separate circuits in the same fixture
- Fault alarm
- Infrared available
- Beacon support bracket
- Automatic changeover from normal to backup light

ELECTRICAL FEATURES

- Power Supply AC or DC
- Power consumption LIOL-B: 4W
- LED feeded at constant current

MECHANICAL FEATURES

- Anodised aluminium body with heat-sink pins on the bottom
- Polycarbonate UV Resistant Dome
- Silicon gasket
- Degree of protection: IP65
- Operating temperature: -25°C to +55°C
- Storage temperature: -25°C to +55°C
- Lamp unit weight: 0,6 Kg

APPLY TO

- Airport - Stack - High Building - Chimney - Tower crane
- Pipe line - Bridge - Radio and television tower
- Transmission line - Wind turbine - Wind mast measurement
- Radar - Antenna

INTERNATIONAL REGULATION

- ICAO Aerodromes -Annex 14 Volume 1, 6th Edition, July 2013 Chapter 6: Low intensity, Type A-B steady burning obstacle light
- FAA AC150/5345-43F E.B. #67
Lamp type L-810
- DGAC/STAC approval nr. 2013A048
- CE marking

AWL - LIOL



info@luxsolar.com - www.luxsolar.com - Ph. +39.0341.260926 - COMBUSTION AND ENERGY

Document is subject to change without any notice

rev_01



COMBUSTION AND ENERGY SRL

Via per Dolzago 21, 23848 - Oggiono (LC) - Italy - Ph. +39 0341.260926 - E-mail: info@luxsolar.com / info@ce2k.com - Web: www.luxsolar.com / www.ce2k.com
LXS and LUXSOLAR are trademarks of Combustion and Energy Srl

Page. 7 of 48 - rev 2.00

LUXSOLAR - AERONAUTICAL LIGHTING

AIRCRAFT WARNING LIGHTS

LIOL - A / LIOL - B

Order code

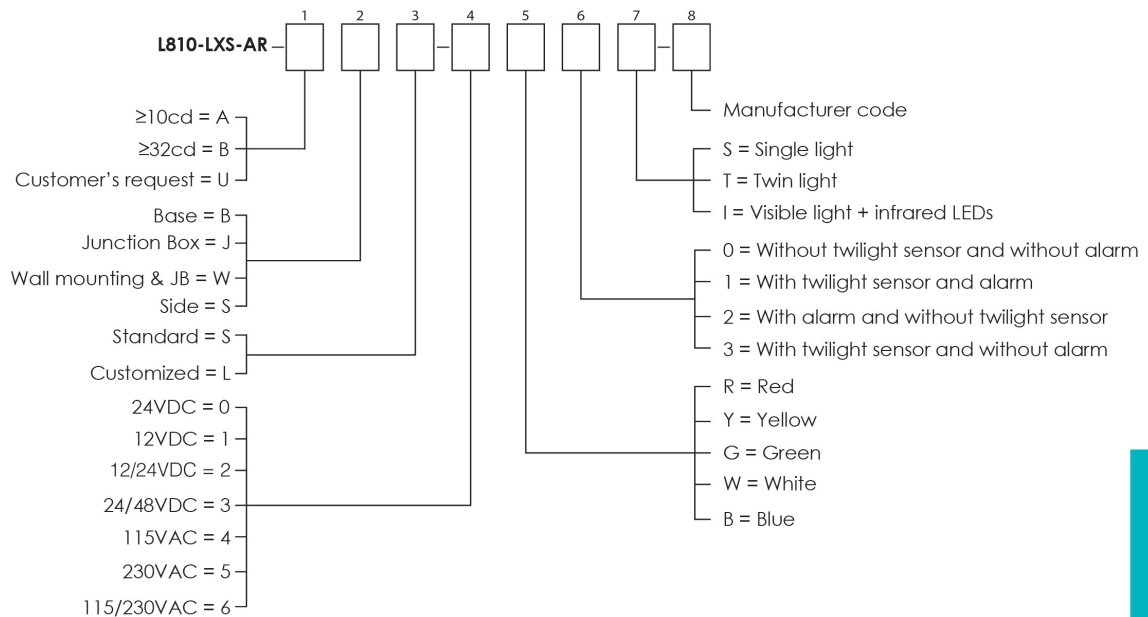

Order Code 2

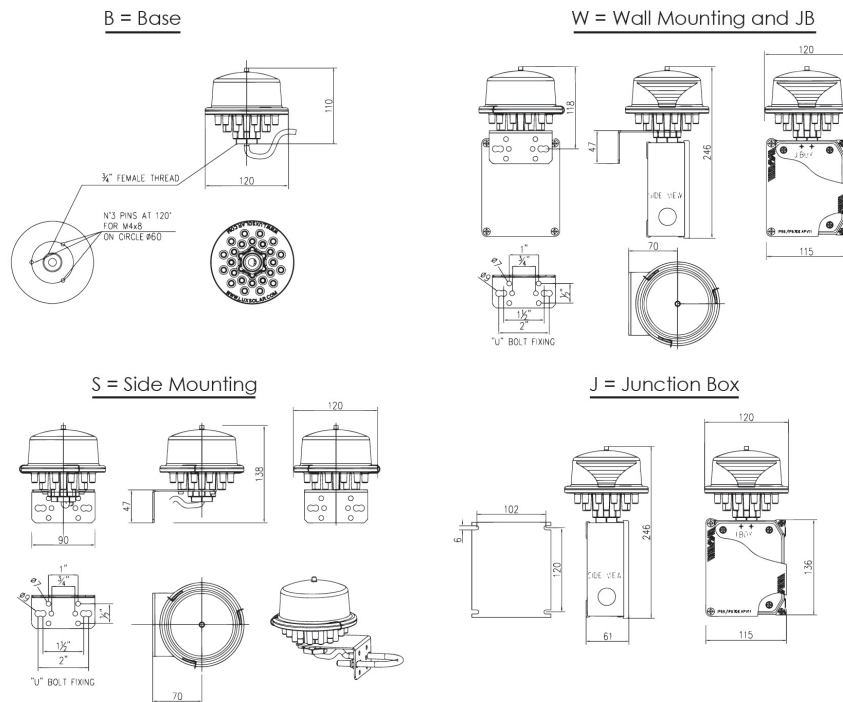

AWL - LIOL

rev_01

COMBUSTION AND ENERGY - info@luxsolar.com - www.luxsolar.com - Ph. +39.0341.260926



COMBUSTION AND ENERGY SRL

Via per Dolzago 21, 23848 - Oggiono (LC) - Italy - Ph. +39 0341.260926 - E-mail: info@luxsolar.com / info@ce2k.com - Web: www.luxsolar.com / www.ce2k.com
LXS and LUXSOLAR are trademarks of Combustion and Energy Srl

LUXSOLAR - AERONAUTICAL LIGHTING

3) ICAO RULES GENERAL CONCEPTS, TYPE OF LAMPS.

Rules Reference:

- ICAO (International Standards and Recommended Practices), Annex 14, Aerodromes, Volume I, Aerodrome Design and Operations, sixth edition July 2013.
- ICAO Aerodrome Design Manual, Part 4, Visual AIDS, fourth edition 2004.
- ICAO Airport Service Manual, Part 9, Airport Maintenance Practices 1984, par. 2.6 Light Maintenance Procedure

The Aircraft Warning Lights (AWL) beacons are designed in accordance to ICAO rules. These rules define the all the optical characteristics of the lights, the number to be installed and the allowed configurations.

Please refer to the table below:

1	2	3	4	5	6	7
Light Type	Colour	Signal Type/ (flash rate)	Peak intensity (cd) at given Background Luminance (b)			Light Distribution Table
			Day (Above 500cd/m ²)	Twilight (50-500cd/m ²)	Night (Below 50cd/m ²)	
Low-intensity, Type A (fixed obstacle)	Red	Fixed	N/A	N/A	10	Table 6-2
Low-intensity, Type B (fixed obstacle)	Red	Fixed	N/A	N/A	32	Table 6-2
Low-intensity, Type C (mobile obstacle)	Yellow/Blue (a)	Flashing (60-90 fpm)	N/A	40	40	Table 6-2
Low-intensity, Type D (follow-me vehicle)	Yellow	Flashing (60-90 fpm)	N/A	200	200	Table 6-2
Medium-intensity, Type A	White	Flashing (20-60 fpm)	20.000	20.000	2.000	Table 6-3
Medium-intensity, Type B	Red	Flashing (20-60 fpm)	N/A	N/A	2.000	Table 6-3
Medium-intensity, Type C	Red	Fixed	N/A	N/A	2.000	Table 6-3
High-intensity, Type A	White	Flashing (40-60 fpm)	200.000	20.000	2.000	Table 6-3
High-intensity, Type B	White	Flashing (40-60 fpm)	100.000	20.000	2.000	Table 6-3

* Document extract from ICAO Annex 14, Aerodromes, Volume I, Table 6-1. "Characteristics of obstacle lights" *

LUXSOLAR - AERONAUTICAL LIGHTING

As you can see there are three big categories of lights: low, medium and high intensity type.

The differences are related to the intensity of lights, colours, flashing or fixed and when the lamps are on or off during the day/night.

Some combinations of lights are also possible, for example medium intensity type AB. In this case the lamp will be white flashing during the day and red flashing during the night.

If the lamps are flashing type and installed on the same structure they have to be synchronized.

On the light intensity of medium and high lamps type there is a tolerance of $\pm 25\%$.

LUXSOLAR - AERONAUTICAL LIGHTING

4) OVERVIEW

The beacons are pre-assembled in factory and can operate with their own power supply circuits.

The necessary power feed the beacon is 1/10 of the power needed for the same beacon incandescent type.

This manual has to be read and understood before doing maintenance on the system or doing the start-up.

For the system functioning and first start-up, please refer to document F.A.T. included in the data book.

Each lamp has a special breathing valve to prevent moisture presence. This device:

- Equalizes pressures to protect housing enclosures and seals;
- Prevent contamination to protect electronics;
- Reduce condensation to protect against corrosion.

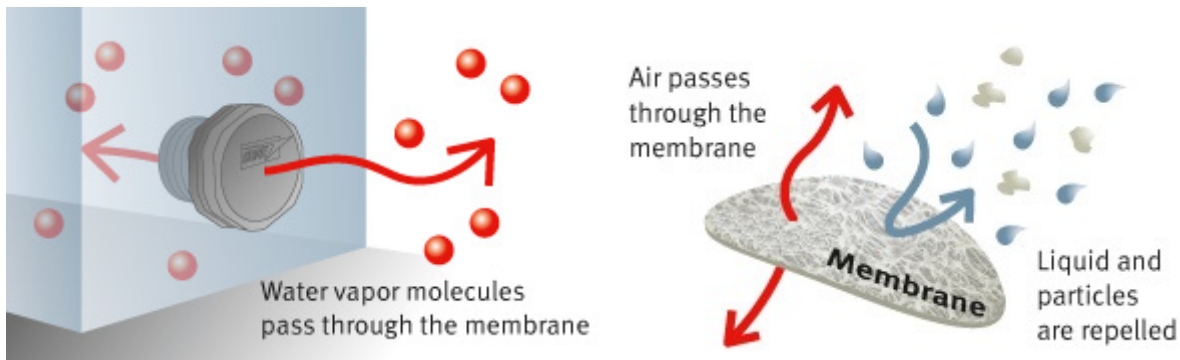

LUXSOLAR - AERONAUTICAL LIGHTING

5) MIOL-B LAMPS EMISSION TESTS.

The Medium Intensity Obstruction Lights (MIOL) for these systems are C type, with 360° radial emission. This means that they have the following intensity:

- Switch off during daytime
- 2.000cd red steady during night time

Reference code number: L864-LXS-B

Night mode (red flashing):

	<i>Minimum</i>	<i>Maximum</i>
<i>Measured Intensity (cd)</i>	2.779	3.479

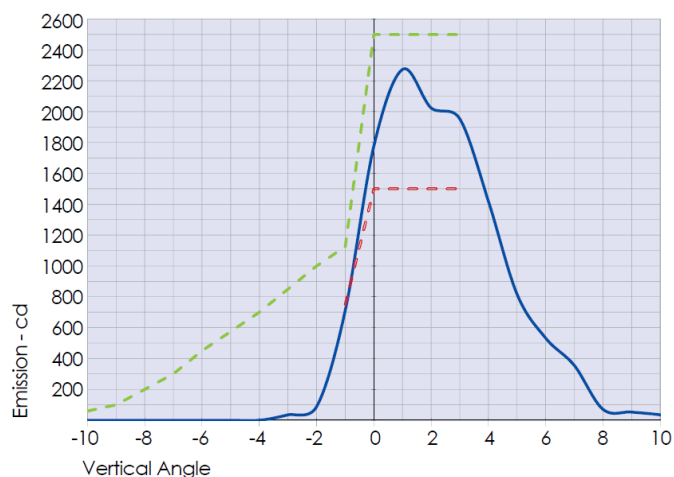

LUXSOLAR - AERONAUTICAL LIGHTING

6) LIOL-B LAMPS EMISSION TESTS.

The Low Intensity Obstruction Lights (LIOL) for these systems are B type, with 360° radial emission. This means that they have the following intensity:

- They are switch off during day time
- 32cd red steady burning during night time

Reference code number: L810-LXS

Night mode (red steady burning):

	<i>Minimum</i>	<i>Maximum</i>
<i>Measured Intensity (cd)</i>	48	90

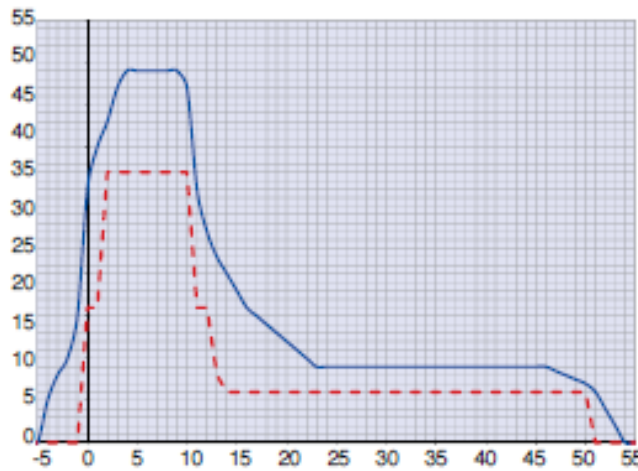

LUXSOLAR - AERONAUTICAL LIGHTING

7) SAFETY NOTICE.

DANGER - ELECTRICAL VOLTAGE

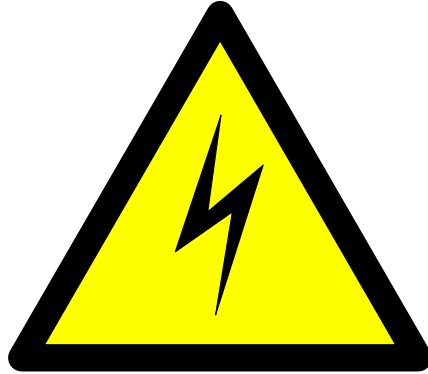

The AWL system associated with the supplied equipment uses 230Vac (as option 24Vdc) and 170Vdc voltage to supply the beacons. This voltage is present all the AWL panels and also inside all the beacons.

In addition some components inside the AWL panels contain capacitors that will retain their charge for several minutes after the main power has been switched off.

To avoid risk of injury we recommend the following precautions:

- Maintenance should only be undertaken by qualified, experienced personnel, familiar with the equipment involved.
- After isolating the power supply wait at least 5 minutes before opening the panel. This allows the capacitors to drain their charge.
- Ensure the system is electrically isolated before attempting maintenance on cables.

DANGER – HIGH BRIGHTNESS

Do not look directly the light source (LED) during system functioning. Considering the high brightness of this source there is an high risk to be dazzled and/or to have temporary or permanent sight injury.

If during maintenance it will be necessary to leave the light on, it will be mandatory to use adequate protection glasses, for the whole time.

LUXSOLAR - AERONAUTICAL LIGHTING

8) TYPE GENERAL LAYOUT AND SYSTEM DESCRIPTION.

MIOL-B AWL systems is used when the structure is higher or equal than 45m.
The lights are installed on the top of the structure MARKED and composed of the following material.

At base structure:

- Nr.01 Base AWL Panel
- Nr.01 Twilight Sensor

At top level:

- Nr.01 or 03 or 04 MIOL-B beacons (depend of the shape and diameter of the structure)

At middle level:

- Nr.03 or 04 LIOL-B beacons (depend of the shape and diameter of the structure)

In the next page it is shown the typical interconnection diagram of the systems. For further details please refer to the dedicated electrical drawing.

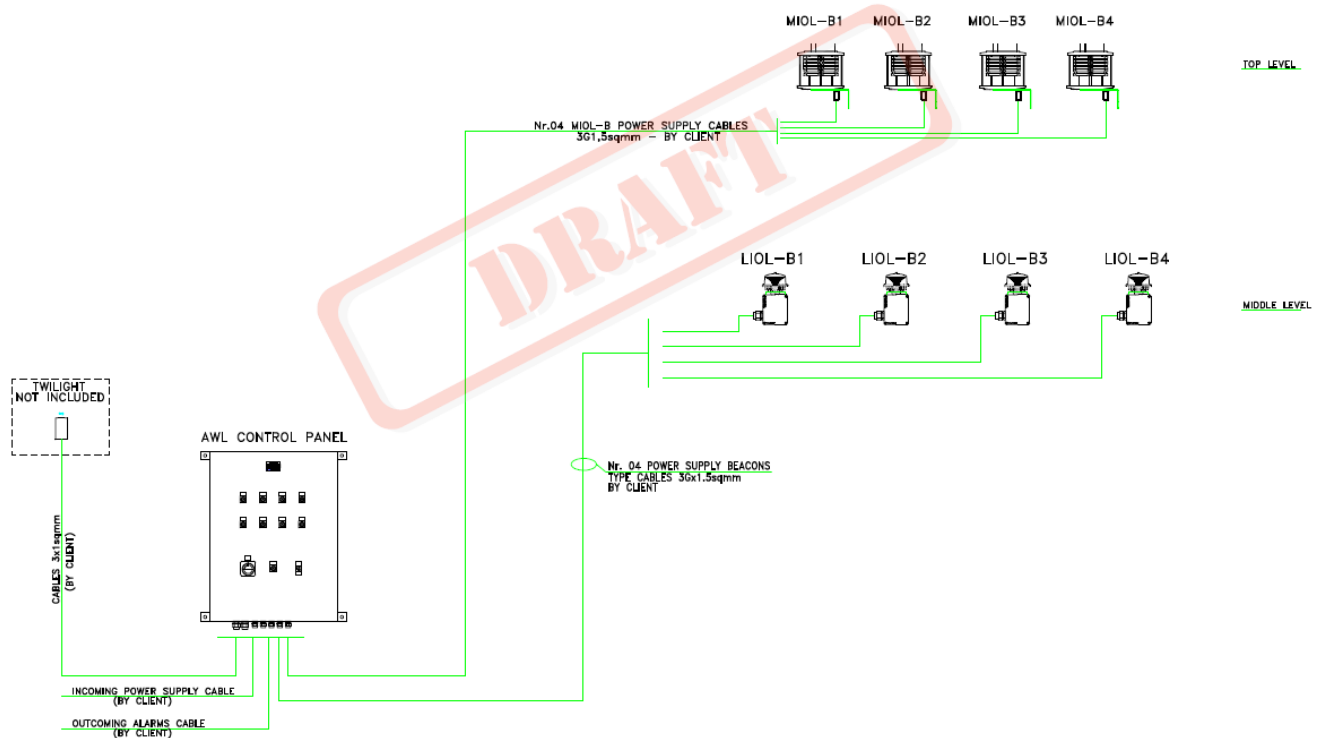

LUXSOLAR - AERONAUTICAL LIGHTING

AWL CONTROL PANEL EXTERNAL LAYOUT

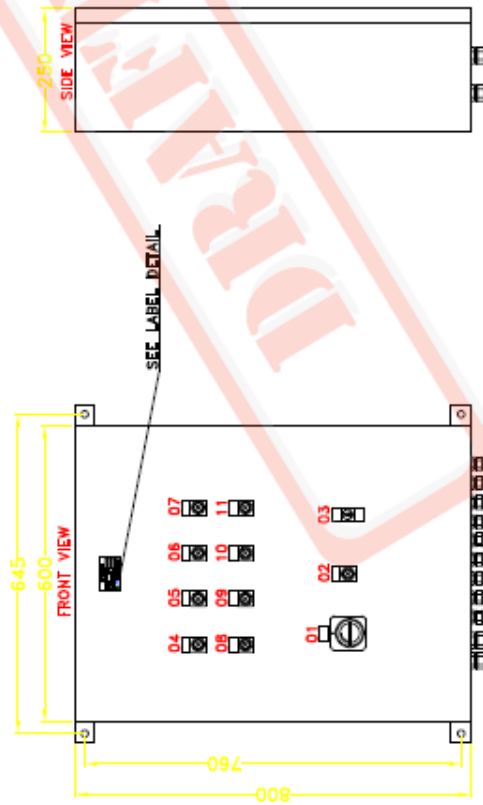

ITEM	DESCRIPTION	TAG
01	MAIN SWITCH - 2 POS. SELECTOR	MS-01
02	POWER ON - WHITE LED 230VAC	XL-01
03	FAULT-FAULT-AUTO - 3 POS. SELECTOR	MS-01
04	WNL-401 BEACON FAULT - RED LED 230VAC	XL-02
05	WNL-402 BEACON FAULT - RED LED 230VAC	XL-03
06	WNL-403 BEACON FAULT - RED LED 230VAC	XL-04
07	WNL-404 BEACON FAULT - RED LED 230VAC	XL-05
08	WNL-405 BEACON FAULT - RED LED 230VAC	XL-06
09	WNL-406 BEACON FAULT - RED LED 230VAC	XL-07
10	WNL-407 BEACON FAULT - RED LED 230VAC	XL-08
11	WNL-408 BEACON FAULT - RED LED 230VAC	XL-09

LABEL DETAILS

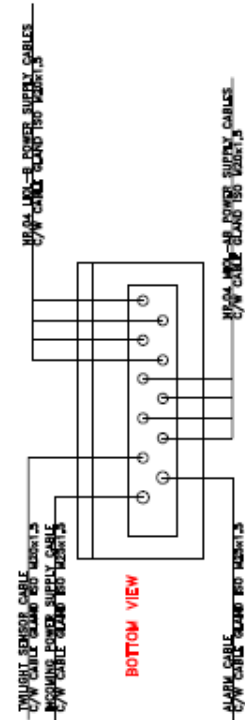

- NOTES:**
- ENCLOSURE MATERIAL: CARBON STEEL
 - DEGREE OF PROTECTION: IP65
 - PAINTING COLOUR: RAL7035
 - CABLE GLANDS: POLYAMIDE TYPE, SINGLE SEAL

LUXSOLAR - AERONAUTICAL LIGHTING

AWL CONTROL PANEL

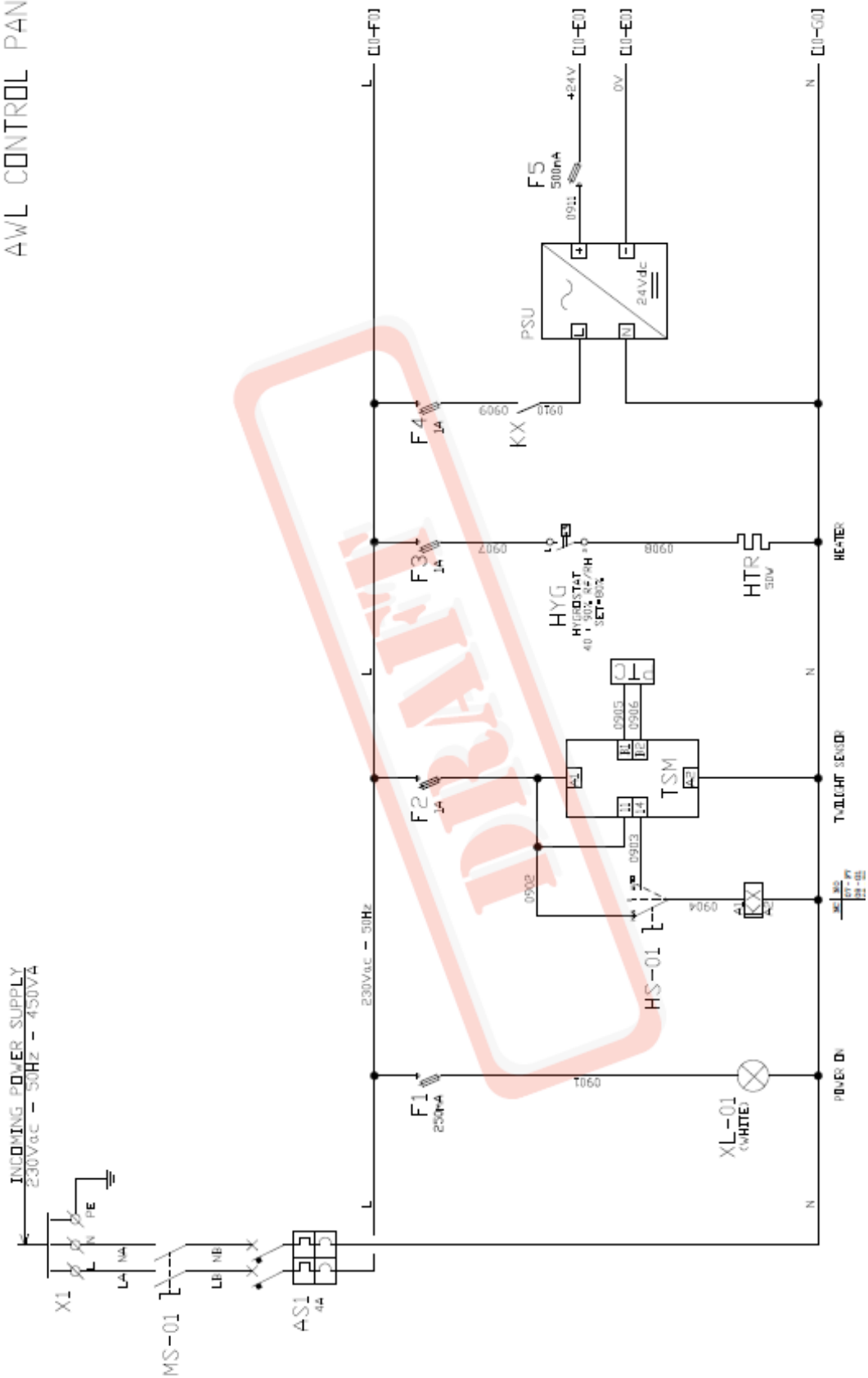

LUXSOLAR - AERONAUTICAL LIGHTING

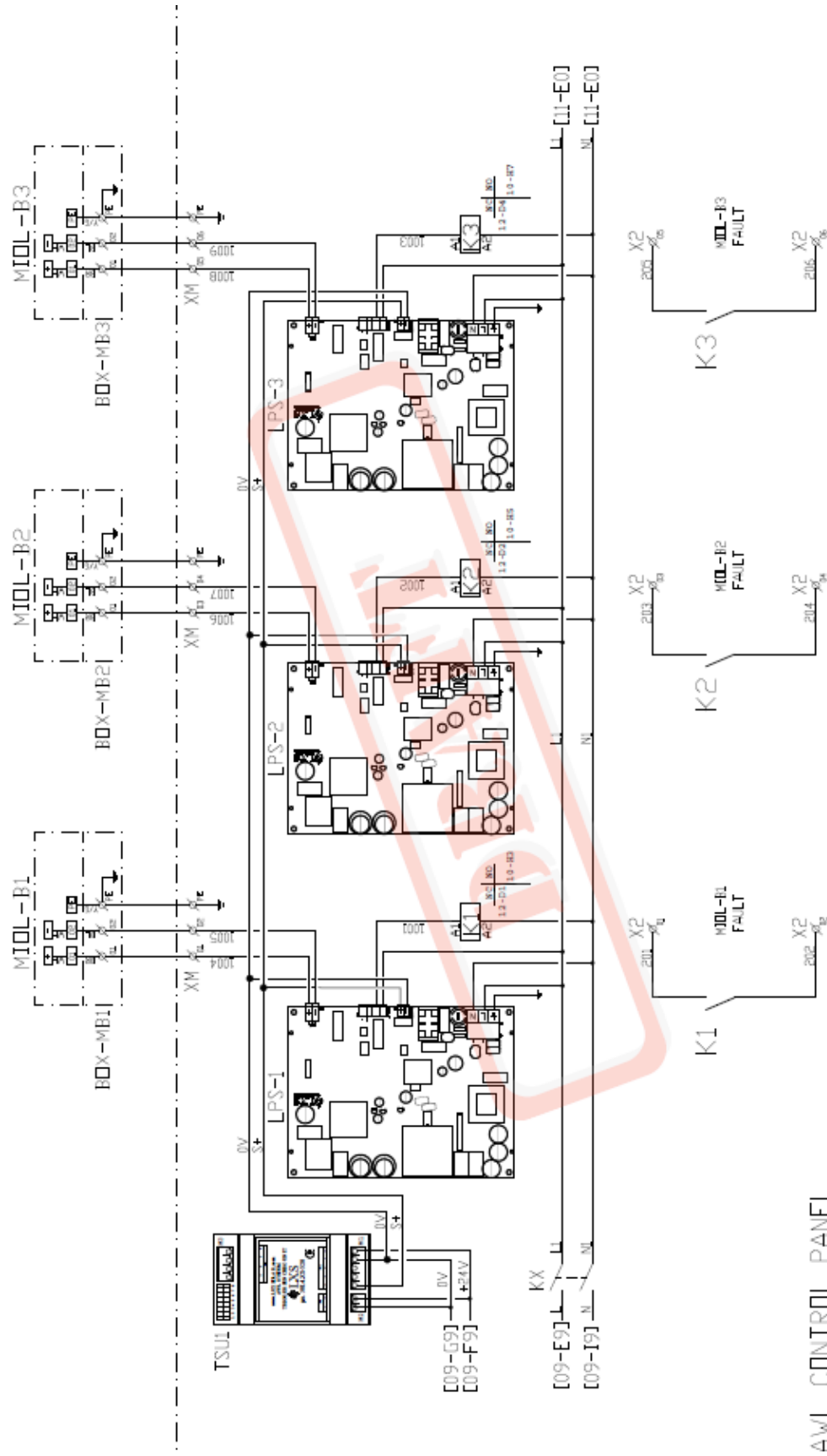

AWL CONTROL PANEL

LUXSOLAR - AERONAUTICAL LIGHTING

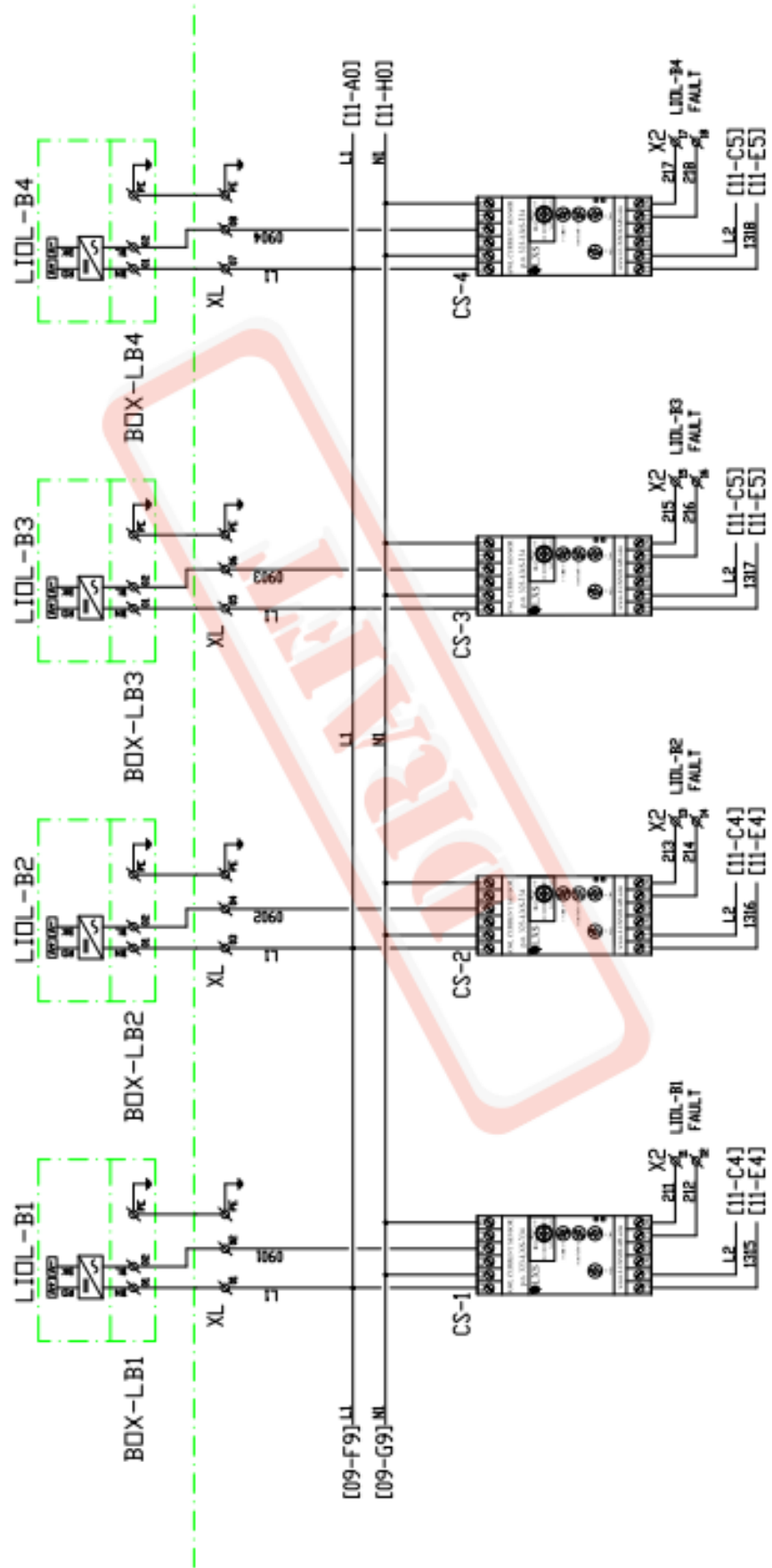

AWL CONTROL PANEL

LUXSOLAR - AERONAUTICAL LIGHTING

9) FIXING DETAILS

Each beacon can be fixed to the structures in difference way, see details below:

MEDIUM INTENSITY TYPE B (L864-LXS-B)

BASE TYPE INSTALLATION

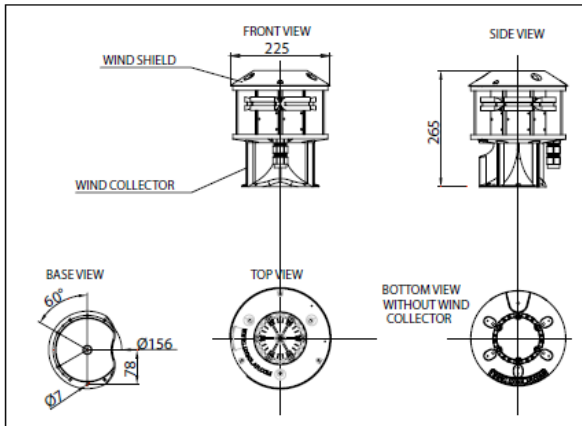

SIDE TYPE INSTALLATION

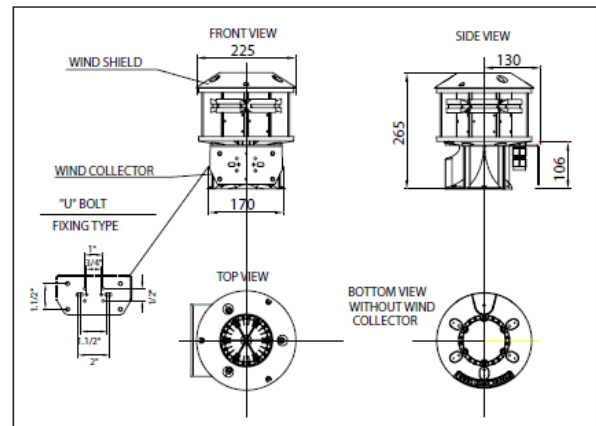

WALL TYPE INSTALLATION

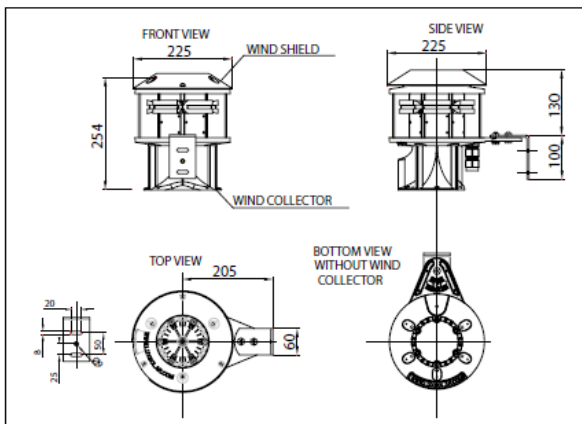

TYPES AVAILABLE

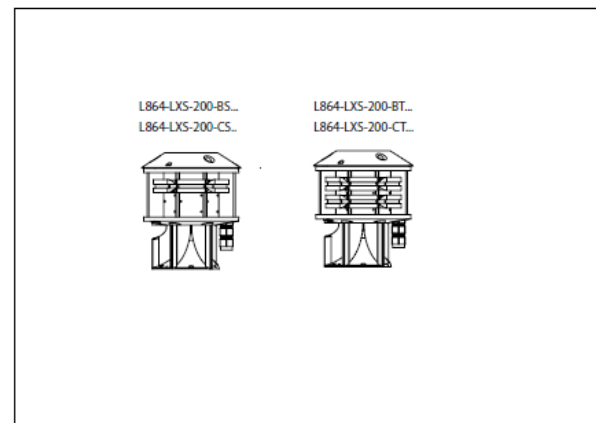

LUXSOLAR - AERONAUTICAL LIGHTING

LOW INTENSITY TYPE B (L810-LXS)

B = Base

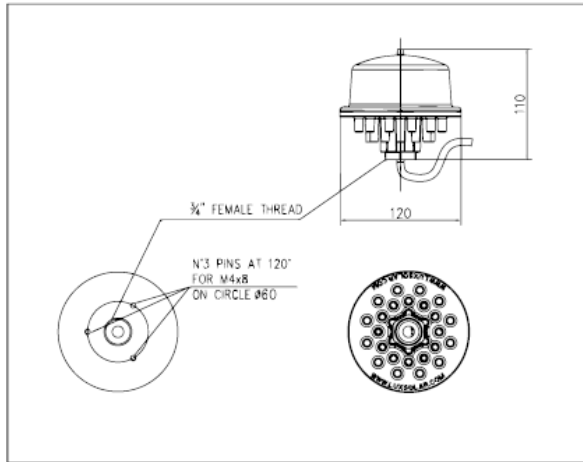

W = JB+S

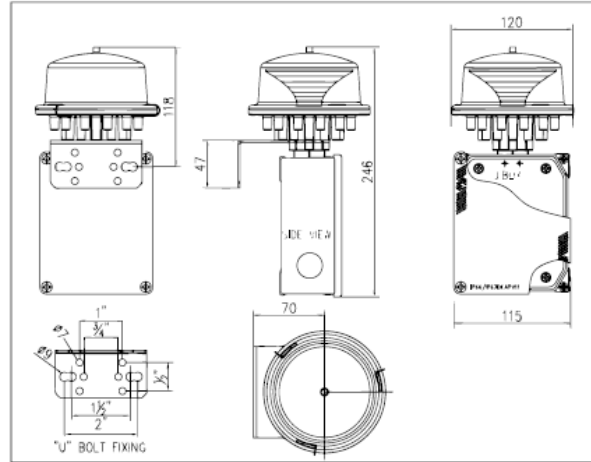

S = Side support plate

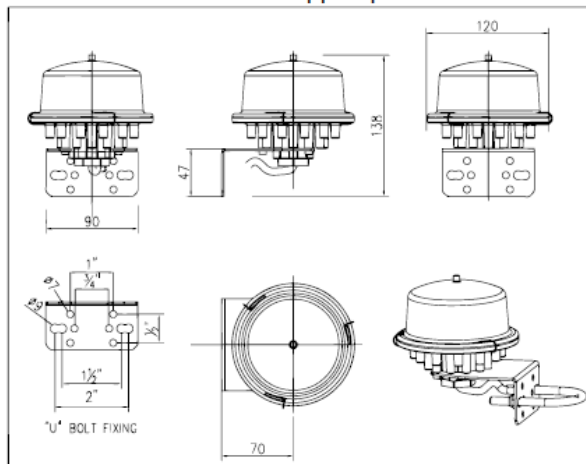

J = With JB

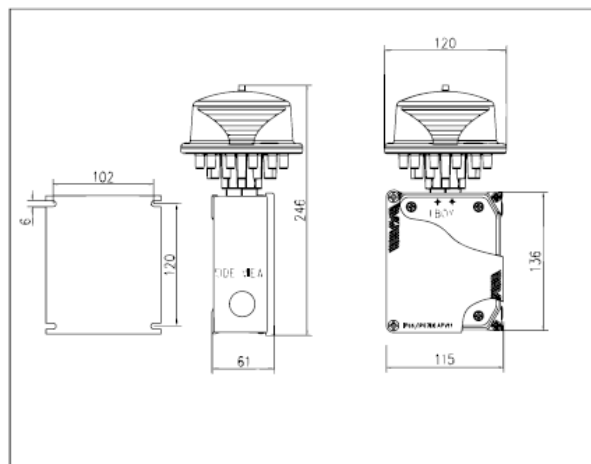

LUXSOLAR - AERONAUTICAL LIGHTING

10) AWL SYSTEMS OPERATIONS

The AWL system is designed to work for night mode only. During normal operation all the MIOL-B beacons are flashing, according to the light condition. It is power supplied with 230Vac 50/60Hz voltage, 1 phase + neutral (or 24Vdc as option). The voltage have to be sinusoidal (in Vac version only) so no square UPS input voltage nor diesel generator type are allowed.

There are Nr.02 functional modes of the system.

- Day mode: all MIOL-B beacons are switched OFF
- Night mode: all MIOL-B beacons are flashing with 2.000cd intensity (red colour) and all the LIOL-B are light on steady burning mode.

The changing from all of these modes is made automatically by the system, through the twilight sensor. This device has to be installed in a safe area, where artificial light is not present (to avoid false reading). It detects the light difference between day and night, so it switches the system into the correct mode. During tests phase or commissioning it is possible to "force" the mode condition by covering or illuminating the sensor. The sensor has an hysteresis of about 1 minute on the reading, so the change is not immediate.

For the start-up please refer to the step by step instruction included in the FAT document

In case of multiple lights, the flashing of all the lamps installed on one structure must be synchronized. This operation is done by the trigger synch unit, code 30L-LXS-520 (TSU component in the drawings) that generate a synch signal to make all the lamps flashing together.

Each MIOL-B beacon is power supplied with Nr.01 electronic boards, code ATB150-LXS for 230Vac inlet or ATC150-LXS for 24Vdc inlet (LPS components in the drawings)
These boards make the LEDs flashing and they also check the lamp status. For further details please refer to next Section 8.

Each LIOL-B beacon is power supplied through Nr.01 current sensor, code 323-LXS-134 (CS components in the drawings). These sensors check the lamp status. For further details please refer to next Section 11.

Once the system has been switched on and tested, it works automatically using the twilight sensor, so it is not necessary to change the mode status manually.

In case of system with multiple light, on the AWL Control Panel can be installed fault status lamps (one for each beacon, or fault beacon level). Inside the panel there are also fault signal contacts, again one for each lamp. When all the beacons are working correctly the signalling lamps are off and the contact are closed. Instead if one or more lamps are faulty the corresponding signalling lamp switches one while the contact opens. For further details please refer to next Section 11.

LUXSOLAR - AERONAUTICAL LIGHTING

11) FAULT DETECTION, ELECTRONIC BOARD DETAILS AND SETTING.

Each MIOL-B beacon is power supplied with Nr.01 electronic boards, code ATB150-LXS for 230Vac or ATC150-LXS for 24Vdc (LPS components in the drawings). These boards make the LEDs flashing and they also check the lamp status. They work all together only during the day and they are divided as per below:

- Electronic boards LPS-1/3/5 work only during day mode
- Electronic boards LPS-2/4/6 work during day and night mode

They have Nr. 08 DIP switches and the correct configuration is the following:

For all LPS-1/2/3/5/6:

- DIP 1 = DIP 2 = DIP 3 = DIP 5 = ON
- DIP 4 = DIP 6 = DIP 7 = DIP 8 = OFF

The electronic board check continuously the beacon status and in case of fault it switches on automatically the fault signalling lamps and the fault contact. The fault condition is activated even if only one of the two boards detect a fault condition.

In addition:

- They have a glass fuse on the input circuit
- They have the input circuit electrically insulated from the output one
- They have an input
- They are protected against reverse connection
- They are protected against LED short or open circuit

Once the system detect fault condition it is possible to understand visually which is the electronic board in this condition. Please refer to the highlighted LEDs on the picture below:



LED1 and LED2 refer to the power supply circuit so once the system is power supplied they have to be on and fixed. Instead LED3 refers to the output so in this case we have three conditions:

- Normal operation: it is on and it flashes according to the MIOL-B lamps. The flash of all LED3 leds is synchronized.
- Faulty operation: it is on and it flashes very fast, with very weak light. The flash is not synchronized with the other LED3 leds.
- Third condition: it is off because it refers to an electronic board that doesn't have to work in the current mode (for example a day board during night).

Each LIOL-B beacon is power supplied with Nr.01 current sensor, code 323-LXS-134 (CS components in the drawings). These sensors check the lamp status by reading its current value.

LUXSOLAR - AERONAUTICAL LIGHTING

They have Nr.05 trimmer and the correct configuration is the following:

- For all CS-1/2:
- Undercurrent No Memory
- I value: 20%
- Hysteresis: 7,5%
- Ti: 4s
- Tt:3s

The current sensor check continuously the beacon status and in case of fault it switches on automatically the fault signalling lamps and the fault contact.

Once the system detect fault condition it is possible to understand visually which is the electronic board in this condition. On the bottom right side of the boards are installed Nr.02 status LEDs. Un refer to the power supply circuit so during the night it has to be on and fixed. Instead R refers to the output so in this case we have two conditions:

- Normal operation: it is on and fixed
- Faulty operation: it is off while Un is on

Once the fault condition is detected please contact our technical office by phone or email for further assistance.

Electronic board PSU regulatory compliance

The AT-150-LXS LED DRIVER PSU, is designed to allow the Warning Beacons to comply with ICAO rules, and FAA, EASA specifications.

The AT-150-LXS LED DRIVER PSU, is designed according to the directive:

2004/108/EC Electromagnetic Compatibility

the conformity is given by the compliance of the following European Standards:

EN 61547 – Lighting devices, EMC immunity

EN 61000-3-2 - (EMC) Part 3.2 EMC limits for current <16A on each phase

CEI EN 55015 limits for radioemissions on lighting

2006/95/EC Low Voltage Directive

the conformity is given by the compliance of the following European Standards:

EN 61347-1 Lamp Controlgear, part 1 general and safety requirements

EN 61347-2-13 Lamp Controlgear, part 2-13: Particular requirements for d.c. or a.c. supplied electronic controlgear for LED modules

Combustion and Energy srl, as manufacturer of AWL beacons, and relevant Driver Circuits declares to operate in accordance with EN-ISO-9001:2000 (cert nr. IQ-1200-15), and 89/392/CEE, 91/368/CEE, 93/44/CEE, 93/68/CEE directives.

Combustion and Energy srl, as manufacturer of AWL beacons, and relevant Driver Circuits inform that the above part of devices can not be in service before that the full device, on which it will be incorporated, as to be declared in conformity to the rules 89/392/CEE.

LUXSOLAR - AERONAUTICAL LIGHTING

PSU LAYOUT

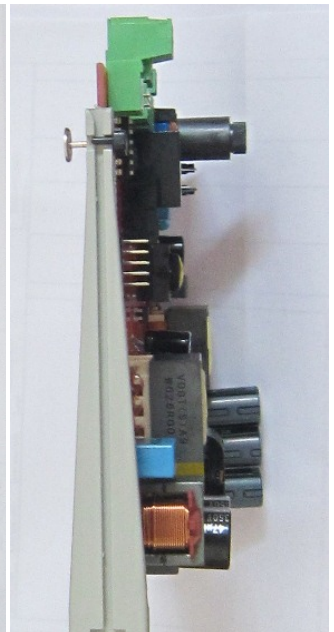
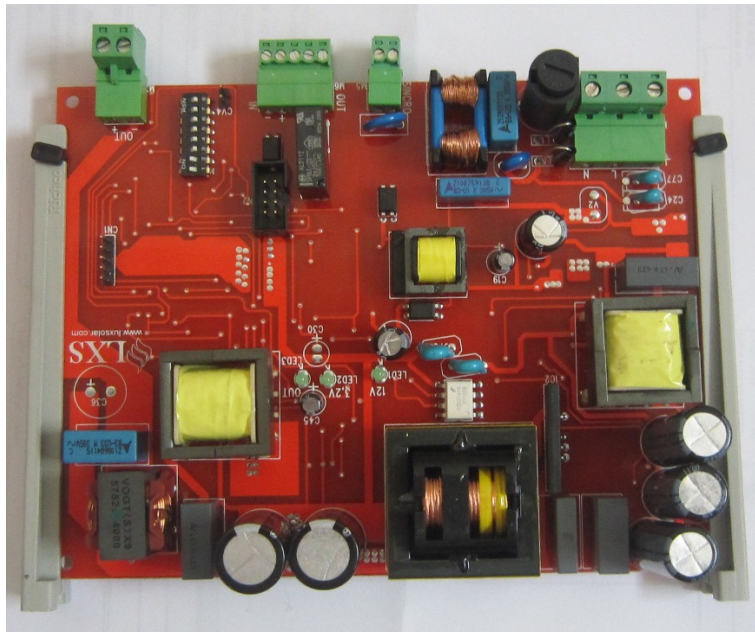
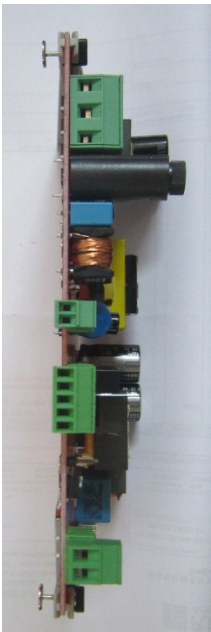
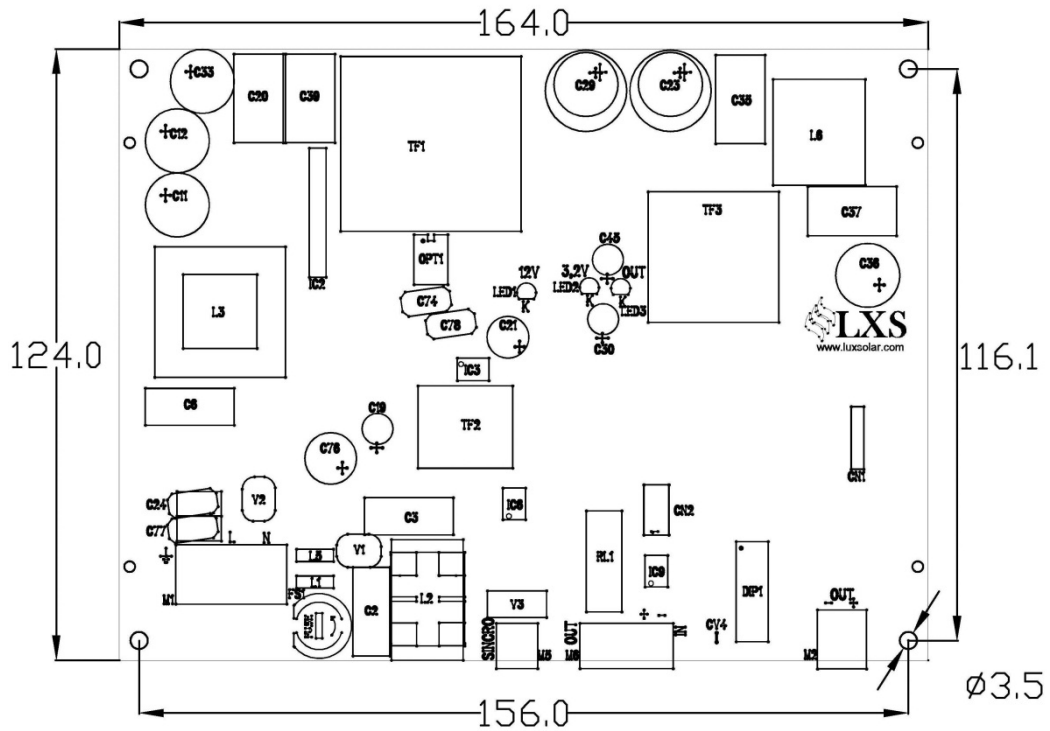

LUXSOLAR - AERONAUTICAL LIGHTING

FIXING POINT FOR RACK MODE

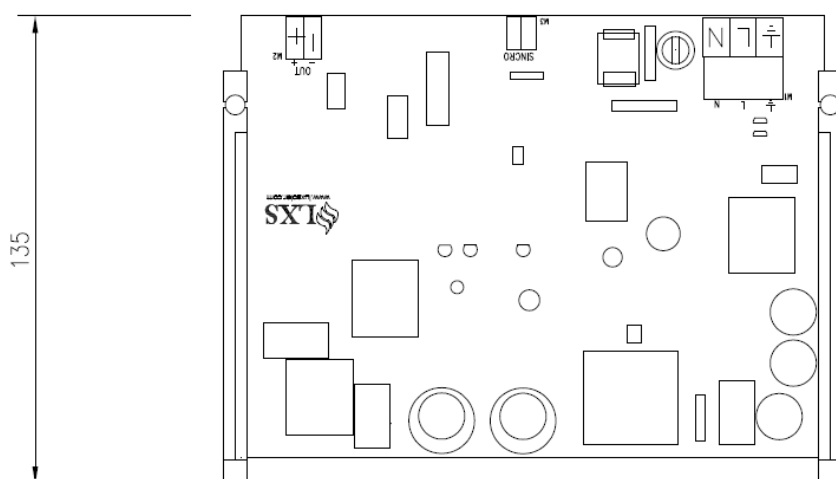
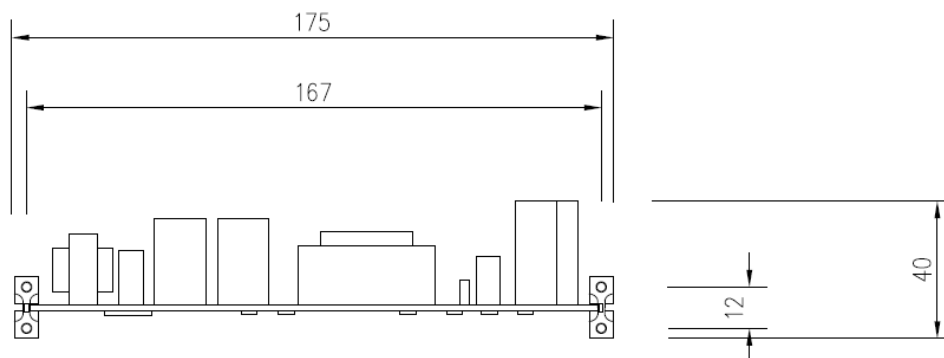

LUXSOLAR - AERONAUTICAL LIGHTING

CONNECTIONS

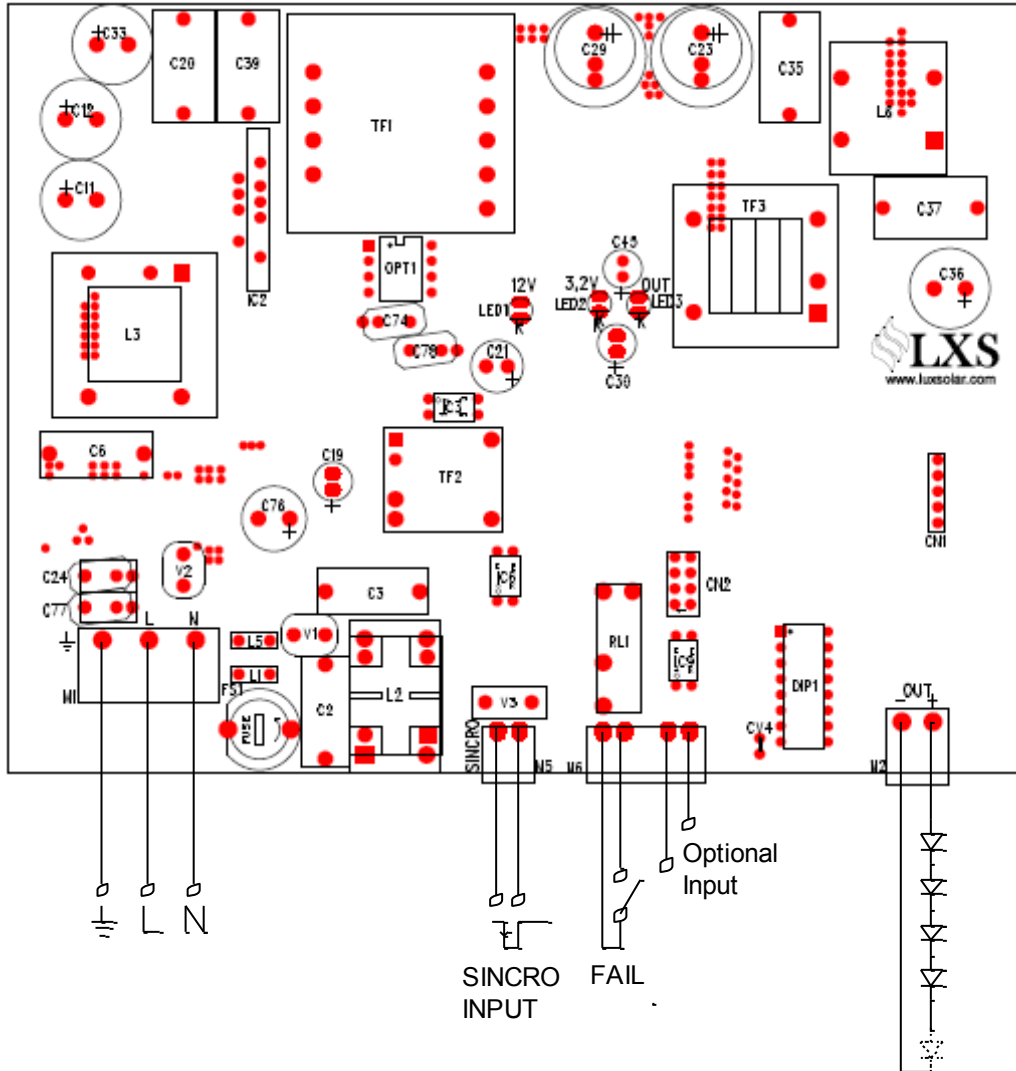

LUXSOLAR - AERONAUTICAL LIGHTING

MAIN DATA

- OUTPUT VOLTAGE:
No Load: Max output voltage = 210 VDC
With Load: Max Output working voltage = 150VDC
- Self Protected circuit against LED reverse polarity connection
- Self Protected circuit against LED short circuit
- Auxiliary Alarm Relay (de energized for alarm or no power)
- Protection Fuse (5x20; 3,15 AT) on inlet phase
- Synchronizations flash output available via AC Net
- For 115Vac application, add autotransformer input 115Vac output 230Vac (optional)
- Continuous power supply 100-130 V dc for max 60W (dip switch 1 & 2 must be set at 0);
200/260 Vdc for max 150W.
- Inrush current: select D curve as for motor starter, or delayed fuse.
- If the AT150 electronic is powered without LEDs connected, the AT150 will enter in safe mode within 500ms; than no power will be available at LED output, even if LED are reconnected. To feed the LEDs, please disconnect power supply, wait at least 2 seconds and reconnect power supply.
- The AT150 has been designed to be connected to expansion card for dimming and for communication.

LUXSOLAR - AERONAUTICAL LIGHTING

PSU CARD Dip Switch setting

1	2	3	4	5	6	7	8	Jumper	Note	Function
0	0									Output for MIOL-B & C
1	0									Output not to be used
0	1									Output not to be used
1	1								1	Output for MIOL-A (multiple cards are required)
		0								Automatic Syncro
		1							2	External Syncro
			0							Flashing light (internal or external syncro)
			1							Steady burning light (bypass syncro)
				0	0					Not to be used
				1	0					200mS ramp 14 mA/mS
				0	1				3	Not to be used
				1	1				3	Not to be used
						0	0			Frequency flashing 20 flash/min
						1	0			Frequency flashing 40 flash/min
						0	1		3	Frequency flashing 50 flash/min
						1	1		3	Frequency flashing 60 flash/min
								0		Normal functionality
								1		Acquisition Aux signal during the start

1. Only for flashing selection; if steady burning set, current will be automatically reduced
2. Dip switch 7 & 8 will not be readied if external syncro is selected.
3. Not applicable for MIOL-A. if set, current will be automatically reduced

LUXSOLAR - AERONAUTICAL LIGHTING

12) MAINTENANCE.

AWL beacons maintenance has to be done in accordance with ICAO rules:

**Airport Service Manual
Part 9
Airport Maintenance Practices
1984
par.2.6 Light Maintenance Procedure**

Maintenance procedure can be resumed as follow:

1) AWL beacons cleaning intervention:

Dust and sand brought by wind to the beacons, often reduce the intensity of the light so they have to be removed. The same thing has to be done for water left on the glass by bugs.

For this reason every two months it is necessary to clean the Beacons glass, with water and suitable fluids. Pay attention!! Do not use corrosive or oily products.

If there will be meteorological phenomenon with dust, the beacons cleaning is required.

2) Damaged beacon replacement

As soon as the broken beacon is detected, replace it immediately with a new one. Do not try to repair it on quote; test and repair the beacons only in laboratory.

3) Periodic check

Climatic conditions, lens degrade and the reduction of the intensity emitted from light source are the causes of possible reduction of the intensity of AWL beacons.

ICAO rules provide that if the light intensity is reduced under the 50% of the specified value, it is necessary the replacement of the beacon.

By the way it is strongly prompted to replace the beacon if the light intensity is less than 70%. A simple light sensor, used overnight, can indicate the light intensity value, that has to be compared with the ICAO one.

The optimum working period of AWL beacons (LED type) can be define in 5 years before beacons replacement.

LUXSOLAR - AERONAUTICAL LIGHTING

MAINTENANCE MODULE

Please send us this report every six months, starting from bill of materials date, at Luxsolar by fax nr. +39 0341 577747.

Others way of sending will not be considered. The compilation of this module is necessary for the warranty.

Date of document: .../.../.....

Person in charge:

Company:

Report number:

Device	State of functioning and preservation			Notes
	Very good	Good	Damaged	
MIOL-B LED beacons				
LIOL-B LED beacons				
Control panels				
Internal wiring				
Twilight sensor				
Interconnection cables				

LUXSOLAR - AERONAUTICAL LIGHTING

13) TROUBLESHOOTING.

Very important! Some of the tests below have to be done with live system. For this reason they should only be undertaken by qualified, experienced personnel, familiar with the equipment involved.

Preliminary tests to be done without power supply:

- Verify the interconnection cables installation (correct pins, bolts tighten etc.)
- Verify that all green connectors on all electrical devices inside the panel are fixed correctly to the related electronic boards
- Verify that all the fuses integrity
- Verify that all the automatic switches are in ON position
- Verify that the system receive 230Vac power supply (or 24Vdc as option)
- Verify if black burnt mark are present on electrical components

Please find here below some fault conditions, with dedicated solution. All the operations that require replacement of components have to be done without power supply.

- *Fault* = all MIOL-B beacons are off
Probable causes = there is no electrical power supply to the system, automatic switches into off position, main switch into 0 position, fused terminals open
Solutions = give power supply to the system, turn automatic switches into on position, turn main switch into 1 position, close fused terminals
- *Fault* = all MIOL-B beacons do not flash
Probable causes = there is no electrical power supply to the system, synch unit in fault
Solutions = give power supply to the system, replace the synch unit
- *Fault* = one MIOL-B or LIOL-B beacon is in fault condition
Probable causes = there is no electrical power supply to the lamp, one or more electronic board are in fault, damaged LEDs inside the beacon, wrong interconnection
Solutions = give power supply to the lamp, replace the electronic board, replace the beacon, change the interconnection

LUXSOLAR - AERONAUTICAL LIGHTING

14)MIOL-AB TESTS: ICAO CERTIFICATION, IP65 TEST, VIBRATION TEST, CLIMATIC TEST REPORT

ICAO CERTIFICATION



MINISTÈRE DE L'ÉCOLOGIE, DU DÉVELOPPEMENT DURABLE
ET DE L'ÉNERGIE



CERTIFICATE OF COMPLIANCE Aeronautical ground lighting N° 2014A018

Cancel and replace the certificate 2013A037 issued on 7th June 2013.

For the following ground lighting :

Type	Medium intensity obstacle light, type B
Brand	Luxsolar
Name	L864-LXS-CG-B
Lighting source(s)	48 LED Cree
Power supply	230V AC
Color	Red
Temperature range	[-20°C ; -45°C]

Issued to **Combustion and Energy SRL**

Referring to the obstacle lighting requirements **PRO/STAC/SE/VIS/6003**, V4 (25/01/2013)

By **Service Technique de l'Aviation Civile**, 23rd September 2014.

This certificate of compliance is only issued for the ground lighting described above. Any other ground lighting resulting from any changes to this latter must be submitted to the STAC approval.

laboratoire-photometrie@aviation-civile.gouv.fr

www.stac.aviation-civile.gouv.fr

Full report is available under request

IP65 TEST REPORT



COMBUSTION AND ENERGY SRL

Via per Dolzago 21, 23848 – Oggiono (LC) – Italy – Ph. +39 0341.260926 – E-mail: info@luxsolar.com /
info@ce2k.com - Web: www.luxsolar.com / www.ce2k.com
LXS and LUXSOLAR are trademarks of Combustion and Energy Srl

LUXSOLAR - AERONAUTICAL LIGHTING



TEST REPORT

Degrees of protection provided by enclosure (IP code)

IPTR_140870-0

Degrees of protection against solid foreign object	
Model and/or type reference	Aircraft Warning Lights beacons
Testing location	Prima Ricerca & Sviluppo
.....	Via Boscone, 68 - 22077 Olgiate Comasco (CO) Italy
Date	2014-07-11

Degree IPnX	1 <input type="checkbox"/>	2 <input type="checkbox"/>	3 <input type="checkbox"/>	4 <input type="checkbox"/>	5 <input type="checkbox"/>	6 <input checked="" type="checkbox"/>
-------------	----------------------------	----------------------------	----------------------------	----------------------------	----------------------------	---------------------------------------

TEST CONDITION			
Ambient temperature	22 °C	Test means	Dust Chamber
Depression	≤20mBar	Duration of test	8 hour

Remark	Verdict
No ingress of dust inside the enclosure.	Pass

Date of issue:
2014-07-11

page 9 of 16

LUXSOLAR - AERONAUTICAL LIGHTING



TEST REPORT
Degrees of protection provided by enclosure (IP code)

IPTR_140870-0

Degrees of protection against water	
Model and/or type reference	Aircraft Warning Lights beacons
Testing location	Prima Ricerca & Sviluppo
.....	Via Boscone, 68 - 22077 Olgiate Comasco (CO) Italy
Date	2014-02-11

Degree IPXn	<input type="checkbox"/> 1	<input type="checkbox"/> 2	<input type="checkbox"/> 3	<input type="checkbox"/> 4	<input checked="" type="checkbox"/> 5	<input type="checkbox"/> 6	<input type="checkbox"/> 7	<input type="checkbox"/> 8
-------------	----------------------------	----------------------------	----------------------------	----------------------------	---------------------------------------	----------------------------	----------------------------	----------------------------

TEST CONDITIONS			
Ambient temperature	22° C	Test means	water jet hose nozzle
Water temperature	20° C	Water level	---
Pressure of the water	12,5 l/min	Duration of test	3 minutes

Remark	Verdict
No ingress of water inside the enclosure	Pass

Date of issue:
2014-07-11

page 12 of 16

Full report is available under request
VIBRATION TEST REPORT



LUXSOLAR - AERONAUTICAL LIGHTING

	Test report n.	597-QL14-R01 ver. 0
	Applicant	COMBUSTION AND ENERGY SRL Via per Dolzago, 21 23848 Oggiono (LC) - Italia
	EUT/Type	MIOL-AB (L864/865-LXS-200)

TEST REPORT Nr. 597-QL14-R01 ver. 0

GENERAL INFORMATION INFORMAZIONI GENERALI	
Addresses Indirizzi	
Applicant Richiedente	COMBUSTION AND ENERGY SRL Via per Dolzago, 21 23848 Oggiono (LC) - Italia
Manufacturer Produttore	Same as applicant Vedi richiedente
Test laboratory Laboratorio di prova	Qualilab s.r.l. Via Trento, 87 25020 – Capriano del Colle (BS)
Dates Date	
Report Date Data preparazione rapporto di prova	Ver.0: 30/07/2014
Equipment under test Dispositivo sottoposto a prova	
Equipment under test Dispositivo sottoposto a prova	Aircraft Warning Lights beacons
Type: Modello:	MIOL-AB (L864/865-LXS-200)
Markings: Marche:	n.a.
Date of receipt: Data ricevimento:	Not relevant for the scope of the test
Date and method of sampling: Data e metodo di campionamento:	Sampling performed by the applicant/campionamento ad opera del richiedente
Applicable norms Norme applicabili	
EN 60068-2-6:2008 and applicant requirements	

The test results and observations indicated in this test report refer exclusively to the samples tested. It is not permitted to transfer the results to other systems or configurations.

The publication or duplication of this test report with enclosures, or Part of this test report or enclosures, without a written consent of the test laboratory is not permitted. The test laboratory not assumes any liability to any party for any loss, expense or damage occasioned by the use of this report. Any use of the laboratory's name or one of its marks for the sale or advertisement of the tested material, product or service must first be approved in writing by the test laboratory.

I risultati e le osservazioni indicate in questo rapporto di prova sono riferite esclusivamente ai campioni testati. Non è permesso utilizzare i risultati e le osservazioni di questo rapporto di prova per altri sistemi o configurazioni.

Non è permessa la pubblicazione o la duplicazione completa o parziale di questo rapporto di prova e dei suoi allegati senza un consenso scritto da parte del laboratorio di prova. Il laboratorio di prova non si assume responsabilità nei confronti di terzi per danni o eventuali costi derivanti dall'utilizzo dei dati presenti in questo rapporto di prova. Ogni uso del nome del laboratorio di prova e dei suoi marchi per la vendita o per pubblicizzare il prodotto testato deve essere prima approvato in forma scritta dal laboratorio di prova.

- 1 - 6
QUALILAB s.r.l. Via Trento, 87 - 25020 - Capriano Del Colle (BS) - info@qualilab.it - www.qualilab.it

LUXSOLAR - AERONAUTICAL LIGHTING

	Test report n.	597-QL14-R01 ver. 0
	Applicant	COMBUSTION AND ENERGY SRL Via per Dolzago, 21 23848 Oggiono (LC) - Italia
	EUT/Type	MIOL-AB (L864/865-LXS-200)

TEST AND RESULTS PROVE E RISULTATI			
Test name Identificazione prova	Test Procedure Procedura di prova	Test requirement Requisito di prova	Result Esito
Sinus Vibration Vibrazione sinusoidale	EN 60068-2-6:2008 Frequency range 5-150 Hz peak to peak Amplitude 7,5 mm Amplitude 20 m/s ² N° 10 sweep/axis Vertical, transversal and longitudinal axis 1 oct/min sweep rate Sample not powered during test Campo di frequenze 5-150Hz ampiezza picco-picco 7,5 mm Ampiezza 20 m/s ² N° 10 cicli/asse Asse verticale, trasversale, longitudinale Velocità ciclo 1 oct/min Campione non alimentato durante la prova	Visual inspection (checking for detachment of the optical system) Ispezione visiva (verifica che il sistema ottico non si stacchi o danneggi)	PASS CONFORME
Sinus Vibration Vibrazione sinusoidale	EN 60068-2-6:2008 Frequency range 5-150 Hz peak to peak Amplitude 15 mm Amplitude 40 m/s ² N° 10 sweep on Vertical axis 1 oct/min sweep rate Sample not powered during test Campo di frequenze 5-155Hz ampiezza picco-picco 15 mm Ampiezza 40 m/s ² N° 10 cicli su asse verticale Velocità ciclo 1 oct/min Campione non alimentato durante la prova	Visual inspection (checking for detachment of the optical system) Ispezione visiva (verifica che il sistema ottico non si stacchi o danneggi)	PASS CONFORME
Sinus Vibration Vibrazione sinusoidale	EN 60068-2-6:2008 Frequency range 10-150 Hz peak to peak Amplitude 22 mm Amplitude 60 m/s ² N° 10 sweep on Vertical axis 1 oct/min sweep rate Sample not powered during test Campo di frequenze 10-150Hz ampiezza picco-picco 22 mm Ampiezza 60 m/s ² N° 10 cicli su asse verticale Velocità ciclo 1 oct/min Campione non alimentato durante la prova	Visual inspection (checking for detachment of the optical system) Ispezione visiva (verifica che il sistema ottico non si stacchi o danneggi)	PASS CONFORME

- 2 - 6
QUALILAB s.r.l.
Via Taranto, 87 - 25020 - Capriano Del Colle (BS), info@qualilab.it , www.qualilab.it

LUXSOLAR - AERONAUTICAL LIGHTING



	Test report n.	597-QL14-R01 ver. 0
	Applicant	COMBUSTION AND ENERGY SRL Via per Dolzago, 21 23848 Oggiono (LC) - Italia
	EUT/Type	MIOL-AB (L864/865-LXS-200)

Sinus Vibration Vibrazione sinusoidale	EN 60068-2-6:2008 Frequency range 10-150 Hz peak to peak Amplitude 30 mm Amplitude 80 m/s ² N° 10 sweep on Vertical axis 1 oct/min sweep rate Sample not powered during test Campo di frequenze 10-150Hz ampiezza picco-picco 30 mm Ampiezza 80 m/s ² N° 10 cicli su asse verticale Velocità ciclo 1 oct/min Campione non alimentato durante la prova.	Visual inspection (checking for detachment of the optical system) Ispezione visiva (verifica che il sistema ottico non si stacchi o danneggi)	PASS CONFORME
---	--	--	-----------------------------------

STATEMENT

The Test Report comprises 6 pages.
 The English version is the only official version of this test report
 Questo rapporto di prova contiene 6 pagine.
 La versione inglese di questo rapporto di prova è l'unica versione ufficiale che fa fede.

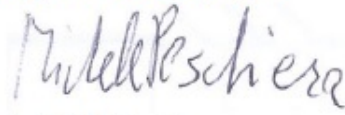
Capriano del Colle, 30/07/2013

Ing. Michele Peschiera
 Testing engineer

- 3 - 6
QUALILAB s.r.l. <small>Via Trento, 87 - 25020 - Capriano Del Colle (BS), info@qualilab.it, www.qualilab.it</small>

Full report is available under request

LUXSOLAR - AERONAUTICAL LIGHTING

15) LIOL-B TESTS: ICAO CERTIFICATION, IP65 TEST, CLIMATIC TEST REPORT

ICAO CERTIFICATION



MINISTÈRE DE L'ÉCOLOGIE, DU DÉVELOPPEMENT DURABLE,
DES TRANSPORTS ET DU LOGEMENT

Direction générale de l'aviation civile

Service technique de l'aviation civile

Département Sécurité Equipements

Division Equipements

CERTIFICATE OF COMPLIANCE aeronautical ground lighting

STAC approval n° 2011A102

Issued to :

PROMIC

**46, rue de la Pierre Plantée
42650 ST-JEAN-BONNEFONDS
France**

Date : 09/12/2011

Material :

Brand or manufacturer	Designation	Material	Colour	Characteristics
Luxsolar	L810-LXS-100 AR	Elevated	Red	8 red LEDs LUXEON-REBEL LXML-PH01-0050

The above referred fitting is compliant with obstacle light, low intensity, type B requirements. The operating range is limited from -25°C to +50°C by manufacturer requirements.

The material approval is five years valid, the expiration date is : 08/12/2016

Ressources, territoires et habitats
Énergie et climat
Prévention des risques
Développement durable
Infrastructures, transports et mer

Présent
pour
l'avenir

www.developpement-durable.gouv.fr

Standards :

STAC : Feux de balisage d'obstacles – Spécifications techniques, PRO/STAC/SE/VIS/6003, V3 dated 22/07/2011
ICAO Annex 14 volume 1, 5^e edition
Industrial's technical documentation

STAC Tests :

Report : RESAN/STAC/SE/PROMIC/11-5403 dated 09/12/2011
Measurements : 253, 254, 255, 256, 257, 258, 292 PP, 248, 249, 250, 259, 260, 261PC

Any optical or mechanical modification must be submitted to the STAC and apply to an approval extension.

BP 53735, 9 avenue du docteur Maurice Grynfolgel
31037 Toulouse Cedex
Tél : 01 49 56 83 00 – Fax: 01 49 56 83 02
www.stac.aviation-civile.gouv.fr



LUXSOLAR - AERONAUTICAL LIGHTING

IP65 TEST REPORT



LAB N° 1244

TEST REPORT ENVIRONMENTAL EN 60529:1991+A1:2000	
Report Reference No.	: 234664TRFENV
Tested by (project handler):	Cristian Simone (project handler) <i>Cristian Simone</i>
Verified by (verificator):	Paolo Barbieri (verificator) <i>Paolo Barbieri</i>
Date of issue	: 2013-04-04
Testing Laboratory	: Nemko Spa
Address	: Via del Carroccio 4 I-20853 Biassono (MB)
Testing location/ procedure.....	: Full application of Harmonised standards <input checked="" type="checkbox"/> Partial application of Harmonised standards <input type="checkbox"/> Other standard testing methods <input type="checkbox"/> Non-standard testing methods <input type="checkbox"/>
Testing location/ address.....	: Nemko Spa - Via del Carroccio 4, I-20853 Biassono (MB)
Applicant's name.....	: Combustion and Energy Srl / Luxsolar
Address	: Via per Dolzago 21 23848 Oggiono LC Italy
Test specification	
Standard	: EN 60529:1991+A1:2000 EN 60598-1:2008 + A11: 2009 (partial application, only §9)
Non-standard test method.....	: N/A
Test Report Form No.	: TRF EN60529
TRF Originator	: Nemko Spa
Master TRF	: 2009-06
Nemko Spa, I-20853 Biassono (MB). All rights reserved.	
This publication may be reproduced in whole or in part for non-commercial purposes as long as the Nemko Spa is acknowledged as copyright owner and source of the material. Nemko Spa takes no responsibility for and will not assume liability for damages resulting from the reader's interpretation of the reproduced material due to its placement and context.	
Test item description:	Indicator LED low intensity obstruction lights
Trade Mark:	Combustion and Energy Srl / Luxsolar
Manufacturer:	Combustion and Energy Srl / Luxsolar
Model:	L-810-LXS-AR
Ratings:	24Vdc, 5W, IP65

*This test report may not be partially reproduced, except with the prior written permission of Nemko Spa
The test report merely corresponds to the test sample.
The phase of sampling / collection of equipment under test is carried out by the customer.*

LUXSOLAR - AERONAUTICAL LIGHTING



ENV -- TEST REPORT

Type / Model: L-810-LXS-AR

Equipment: Indicator LED low intensity obstruction lights

Applicant: Combustion and Energy Srl / Luxsolar

Address: Via per Dolzago 21
23848 Oggiono LC
Italy

Manufacturer: Combustion and Energy Srl / Luxsolar

Address: Via per Dolzago 21
23848 Oggiono LC
Italy

Date of receipt of test sample 2013-03-27

Testing commenced on 2013-04-02

Testing concluded on 2013-04-03

Test Result (according to the standards on page 4)	POSITIVE
---	-----------------

The test report merely corresponds to the test sample.

LUXSOLAR - AERONAUTICAL LIGHTING



6. TEST CONDITIONS AND RESULTS

6.1 IP 6X

Test performed in a dust chamber containing talcum powder able to pass through a square-meshed sieve whose nominal wire diameter is 50 µm and whose nominal free distance between wires is 75 µm.

Test proceeds as follows:

- The luminaire was suspended outside the dust chamber and operated at rated supply voltage until operating temperature was reached,
- The luminaire, whilst still operating, was placed with the minimum disturbance in the dust chamber,
- The door of the dust chamber was closed,
- The fan/blower causing the talcum powder to be in suspension was switched on,
- After 1 min, the luminaire was switched off and allowed to cool for 3 hours whilst the talcum powder remained in suspension.

6.1.1 Photo documentation of the test set-up



Pic.1

6.1.2 Test results

Mod.	IP6X dust test	Result The requirements are
L-810-LXS-AR	Dust was not present inside the enclosure and on live parts	Fulfilled
Note: --		

LUXSOLAR - AERONAUTICAL LIGHTING



LAB N° 1244

6.2 IP X5

Test duration : 15 min.
Flow rate : 12.5 l/min.
Internal diameter of the nozzle:..... : 6,3 mm
Distance from nozzle to enclosure surface..... : 3 m.

6.2.1 Photo documentation of the test set-up.



Pic.2

6.2.2 Test results

MOD.	IPX5 Water test	Result The requirements are
L-810-LXS- AR	Water was not present inside the enclosure and on live parts	Fulfilled
Note: –		

7. TEST EQUIPMENT

Equipment used for testing are recorded and saved into the company archive as file 234664-INS.doc

It will be made available if requested.

LUXSOLAR - AERONAUTICAL LIGHTING

CLIMATIC TEST REPORT



CLIMATIC TEST REPORT

CLITR_140989-1

Prima Ricerca & Sviluppo S.r.l. - Capitale Sociale € 50.000 i.v.
Codice Fiscale e Partita IVA 02635860139 - Uff. registro di COMO - n.REA CO270979
Via Campagna, 92 - I - 22020 Faloppio (Co) - Tel. +39 031.3500011 Fax +39 031.991309
www.primaricerca.it, info@primaricerca.it

EQUIPMENT UNDER TEST : Lampeggiante Bassa Intensità (L810-LXS)

CUSTOMER:

- Dept. / Firm : Combustion and energy SRL
- Mrs.: Sansoni
- Address: Via per Dolzago 21 – 23848 OGGIONO – LC
- Tel: +39 0341 260928 • Fax: +39 - • E-mail: a.digiovine@ce2k.com;
led@luxsolar.com

REFERENCE STANDARDS : EN 60068-2-1 (2007-04) - Prova Ae: Freddo, per campioni che dissipano calore con cambiamento graduale della temperatura cui viene richiesto di essere alimentati durante la prova
EN 60068-2-2 (2007-09) - Prova Be: prova di caldo secco per campioni dissipanti calore con variazione graduale di temperatura e alimentati per tutta la durata della prova

Test Laboratory: Prima Ricerca & Sviluppo S.r.l.
Via Campagna, 92 - 22020 Faloppio fraz. Gaggino (CO) - Italy

Site of test execution: Prima Ricerca & Sviluppo S.r.l.
Via Boscone - Olgiate Comasco (CO) - Italy

Date of test samples receipt: 2014, July Date of test start: 2014-07-31 Date of test end: 2014-08-02

Witness to the test:

Compiled by:

Approved by:

Nobody

Gianluigi Verga

Giovanni Molteni

2014-08-13

sheet 1 of 13

LUXSOLAR - AERONAUTICAL LIGHTING



CLIMATIC TEST REPORT

CLITR_140989-1

Prima Ricerca & Sviluppo S.r.l. - Capitale Sociale € 50.000 i.v.
Codice Fiscale e Partita IVA 02635860139 - Uff. registro di COMO - n.REA CO270979
Via Campagna, 92 - I - 22020 Faloppio (Co) - Tel +39 031.3500011 Fax +39 031.991309
www.primaricerca.it; info@primaricerca.it

5. SUMMARY OF TEST RESULTS

Test		Page	Test results	
<u>1</u>	<u>COLD TEST (OPERATING)</u> Test Ae <ul style="list-style-type: none">• Temperatura: -20 °C• Durata: 24 h	<u>7</u>	<input checked="" type="checkbox"/> PASS	<input type="checkbox"/> FAIL
<u>2</u>	<u>DRY HEAT TEST (OPERATING) :</u> Test Be <ul style="list-style-type: none">• Temperatura: +50 °C• Durata: 24 h	<u>8</u>	<input checked="" type="checkbox"/> PASS	<input type="checkbox"/> FAIL

2014-08-13

sheet 6 of 13

LUXSOLAR - AERONAUTICAL LIGHTING



CLIMATIC TEST REPORT

CLITR_140989-1

Prima Ricerca & Sviluppo S.r.l. - Capitale Sociale € 50.000 i.v.
Codice Fiscale e Partita IVA 02635860139 - Uff. registro di COMO - n.REA CO270979
Via Campagna, 92 - I - 22020 Faloppio (Co) - Tel +39 031.3500011 Fax +39 031.991309
www.primaricerca.it; info@primaricerca.it

The cold test

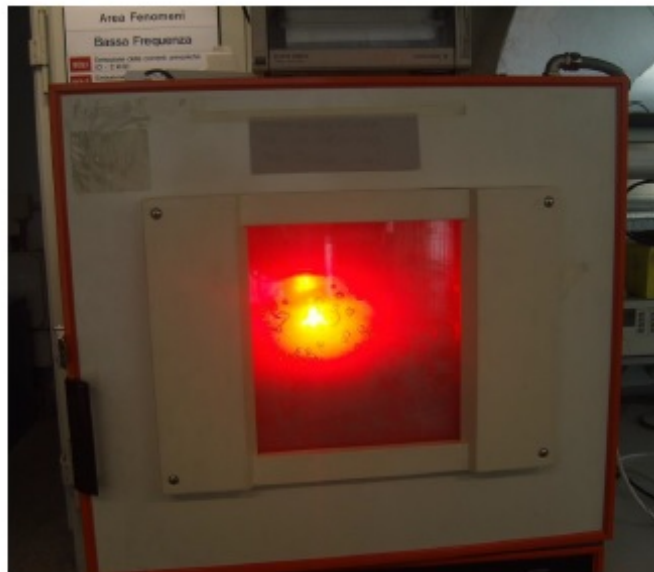

2014-08-13

sheet 11 of 13

LUXSOLAR - AERONAUTICAL LIGHTING



CLIMATIC TEST REPORT

CLITR_140989-1

Prima Ricerca & Sviluppo S.r.l. - Capitale Sociale € 50.000 i.v.
Codice Fiscale e Partita IVA 02635860139 - U.F. registro di COMO - n.REA CO270979
Via Campagna, 92 - I - 22020 Faloppio (Co) - Tel +39 031.3500011 Fax +39 031.991309
www.primaricerca.it; info@primaricerca.it

The dry heat test

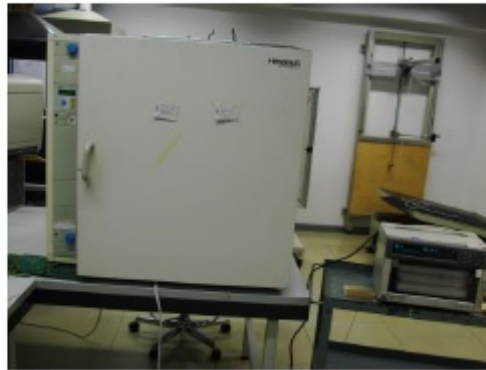
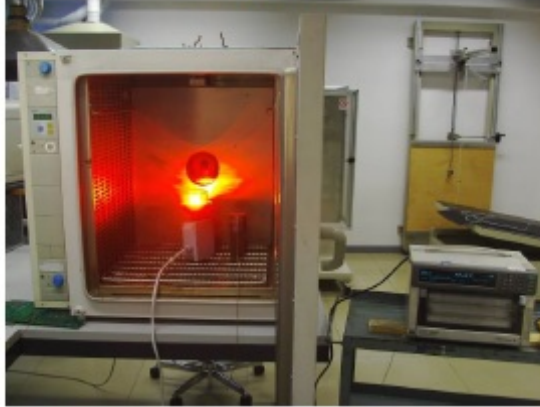

End of the dry heat test

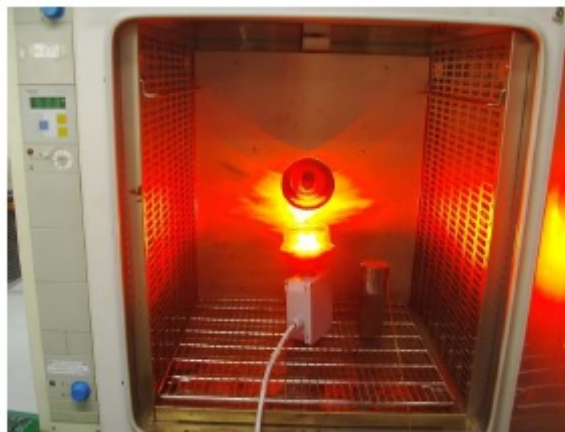

2014-08-13

sheet 13 of 13

LUXSOLAR - AERONAUTICAL LIGHTING

16) WARRANTY.

LUXSOLAR Warranty, Obstruction Lighting

C&E srl – “Luxsolar” warrants the purchaser and the final user of AWL LED beacons “Luxsolar” that at the moment of their purchase the products were exempt of shortages and conform with ICAO Annex 14 requirements.

3 years warranty for materials and labor

For a period of five years from the purchase date, “Luxsolar”, at its unchallengeable opinion, provides to repair or replace lacking product, directly or through other companies and people. Warranty is applicable only in case of factory default or assembly default.

3 years warranty for light degradation

For a period of five years from installation date, “Luxsolar” at its unchallengeable opinion, provides to repair or replace (directly or through other companies and people) the product having a light intensity 7% lower than the intensity required according to ICAO Annex 14 June 2004 rules .

Warranty does not cover: (1) advice or information complementary given by “Luxsolar”, (2) assembly and disassembly of products, (3) Fault or lacks caused by accidents, modifications, wrong use, environment temperature >55°C, voltage value higher than the indicated one, wrong maintenance, abuse, wrong installation and wrong storage.

Warranty conditions: (1)The user has to communicate and detail the shortage or the reduction of light intensity before the end of the warranty period; (2) Ship the product with a copy of the purchase order and the name of the original purchaser; (3) The user has to pre-pay all shipping costs (including insurance), from plant to Luxsolar and from Luxsolar to plant for repaired and/or replaced parts; (4) Luxsolar is authorized to detain repaired/replaced parts; (5) every six months, starting bill of material 's date, User has to send the maintenance module -entirely compiled- to Luxsolar service center, exclusively by FAX (no. +39-0341-577747). If this module will not be sent, warranty will not be applied to repair/replacement.

Warranty limitations: this warranty will not cover other suppliers' products. All the replaced/repared products will be covered by warranty only for the remaining warranty period. The replaced products will not be necessarily identical to original ones, though having the same functionality. Repairs, replacements or compensations are the only remedies agreed by this warranty.

“Luxsolar” declines any other kind of warranty, included, without limitations, the implicit warranty of commercial use and suitability for other uses.

Damage limitations: Under no circumstances “LUXSOLAR” will be liable for incidental or accidental damages and loss of profits or savings - suffered by purchaser or third part - that may be caused by its products or by failure of its products. This limitation will be effective even if damage and loss have been caused by “Luxsolar” or its representative’s negligence and even if “Luxsolar” is informed about the possibility of such damages and losses. This limitation of liability may not apply to damages relating to personal injury or death in jurisdictions where such damages may not be disclaimed as a matter of law.

To obtain warranty service, user has to ask (by fax +39-0341-577747) and obtain the authorization return number of material (ARM) from Luxsolar Service Centre.