



8-inch Inset AD-light Type DTS / DTC / DFS

## User Manual

AM.04.510e, Rev. 3.3, 2021/10/13

  
**ADB  
SAFEGATE**



## A.0 Disclaimer / Standard Warranty

### CE certification

The equipment listed as CE certified means that the product complies with the essential requirements concerning safety and hygiene. The European directives that have been taken into consideration in the design are available on written request to ADB SAFEGATE.

### ETL certification

The equipment listed as ETL certified means that the product complies with the essential requirements concerning safety and FAA Airfield regulations. The FAA directives that have been taken into consideration in the design are available on written request to ADB SAFEGATE.

### All Products Guarantee

ADB SAFEGATE will correct by repair or replacement per the applicable guarantee above, at its option, equipment or parts which fail because of mechanical, electrical or physical defects, provided that the goods have been properly handled and stored prior to installation, properly installed and properly operated after installation, and provided further that Buyer gives ADB SAFEGATE written notice of such defects after delivery of the goods to Buyer. Refer to the Safety section for more information on Material Handling Precautions and Storage precautions that must be followed.

ADB SAFEGATE reserves the right to examine goods upon which a claim is made. Said goods must be presented in the same condition as when the defect therein was discovered. ADB SAFEGATE further reserves the right to require the return of such goods to establish any claim.

ADB SAFEGATE's obligation under this guarantee is limited to making repair or replacement within a reasonable time after receipt of such written notice and does not include any other costs such as the cost of removal of defective part, installation of repaired product, labor or consequential damages of any kind, the exclusive remedy being to require such new parts to be furnished.

ADB SAFEGATE's liability under no circumstances will exceed the contract price of goods claimed to be defective. Any returns under this guarantee are to be on a transportation charges prepaid basis. For products not manufactured by, but sold by ADB SAFEGATE, warranty is limited to that extended by the original manufacturer. This is ADB SAFEGATE's sole guarantee and warranty with respect to the goods; there are no express warranties or warranties of fitness for any particular purpose or any implied warranties of fitness for any particular purpose or any implied warranties other than those made expressly herein. All such warranties being expressly disclaimed.

### Standard Products Guarantee

Products manufactured by ADB SAFEGATE are guaranteed against mechanical, electrical, and physical defects (excluding lamps) which may occur during proper and normal use for a period of two years from the date of ex-works delivery, and are guaranteed to be merchantable and fit for the ordinary purposes for which such products are made.



### Note

See your sales order contract for a complete warranty description.

Replaced or repaired equipment under warranty falls into the warranty of the original delivery. No new warranty period is started for these replaced or repaired products.

### FAA Certified products manufactured by ADB SAFEGATE

ADB SAFEGATE L858 Airfield Guidance Signs are warranted against mechanical and physical defects in design or manufacture for a period of 2 years from date of installation, per FAA AC 150/5345-44 (applicable edition).

ADB SAFEGATE LED products (with the exception of obstruction lighting) are warranted against electrical defects in design or manufacture of the LED or LED specific circuitry for a period of 4 years from date of installation, per FAA EB67 (applicable edition). These FAA certified constant current (series) powered LED products must be installed, interfaced and powered with and through products certified under the FAA Airfield Lighting Equipment Program (ALECP) to be included in this 4 (four) year warranty. This includes, but is not limited to, interface with products such as Base Cans, Isolation Transformers, Connectors, Wiring, and Constant Current Regulators.



## Note

See your sales order contract for a complete warranty description.

Replaced or repaired equipment under warranty falls into the warranty of the original delivery. No new warranty period is started for these replaced or repaired products.

---

## Liability

---



### WARNING

Use of the equipment in ways other than described in the catalog leaflet and the manual may result in personal injury, death, or property and equipment damage. Use this equipment only as described in the manual.

---

ADB SAFEGATE cannot be held responsible for injuries or damages resulting from non-standard, unintended uses of its equipment. The equipment is designed and intended only for the purpose described in the manual. Uses not described in the manual are considered unintended uses and may result in serious personal injury, death or property damage.

Unintended uses, includes the following actions:

- Making changes to equipment that have not been recommended or described in this manual or using parts that are not genuine ADB SAFEGATE replacement parts or accessories.
- Failing to make sure that auxiliary equipment complies with approval agency requirements, local codes, and all applicable safety standards if not in contradiction with the general rules.
- Using materials or auxiliary equipment that are inappropriate or incompatible with your ADB SAFEGATE equipment.
- Allowing unskilled personnel to perform any task on or with the equipment.

## © ADB SAFEGATE BV

This manual or parts thereof may not be reproduced, stored in a retrieval system, or transmitted, in any form or by any means, electronic, mechanical, photocopying, recording, nor otherwise, without ADB SAFEGATE BV's prior written consent.

This manual could contain technical inaccuracies or typographical errors. ADB SAFEGATE BV reserves the right to revise this manual from time to time in the contents thereof without obligation of ADB SAFEGATE BV to notify any person of such revision or change. Details and values given in this manual are average values and have been compiled with care. They are not binding, however, and ADB SAFEGATE BV disclaims any liability for damages or detriments suffered as a result of reliance on the information given herein or the use of products, processes or equipment to which this manual refers. No warranty is made that the use of the information or of the products, processes or equipment to which this manual refers will not infringe any third party's patents or rights. The information given does not release the buyer from making their own experiments and tests.

# TABLE OF CONTENTS

<b>1.0 Safety</b> .....	<b>1</b>
1.1 Safety Messages .....	1
1.1.1 Introduction to Safety .....	2
1.1.2 Intended Use .....	2
1.1.3 Material Handling Precautions: Storage .....	3
1.1.4 Material Handling Precautions: Fasteners .....	3
1.1.5 Operation Safety .....	4
1.1.6 Maintenance Safety .....	4
1.1.7 Material Handling Precautions, ESD .....	5
1.1.8 Arc Flash and Electric Shock Hazard .....	5
<b>2.0 About this manual</b> .....	<b>7</b>
2.1 How to work with the manual .....	7
2.2 Abbreviations and terms .....	7
<b>3.0 Description</b> .....	<b>9</b>
3.1 Overview .....	9
3.2 LED Taxiway Centerline, Stop Bar and Holding Position Inset Light .....	9
3.3 APS version .....	15
3.4 Identification on the fixture .....	15
3.4.1 Top .....	15
3.4.2 Bottom .....	15
<b>4.0 Installation</b> .....	<b>17</b>
4.1 Overview of Sequence of Work .....	17
4.2 Installation Overview .....	17
4.3 INTEROPERABILITY .....	18
4.4 Typical L-868 Assembly .....	19
4.5 Safety Considerations .....	20
4.6 Photobiological safety .....	20
4.7 Verify Input Requirements and Equipment Needed .....	20
4.8 Unpacking the Unit .....	21
4.9 Inspect on delivery .....	21
4.10 Store .....	22
4.11 Installation on L-868 Base .....	22
4.12 Torquing and Installation Guidance for In-pavement Fixtures .....	23
4.13 Shallow base can installation .....	24
4.13.1 Installation on a Shallow Base .....	24
<b>5.0 Maintenance</b> .....	<b>27</b>
5.1 Preventive maintenance schedule .....	27
5.2 Part replacement .....	27
5.2.1 How to replace parts - general procedure .....	28
5.2.2 Replace upper cover assy .....	28
5.2.3 Replace prism .....	30
5.2.4 Replace optical assy .....	31
5.2.5 Replace inner cover assy .....	34
5.2.6 Replace cable lead .....	34
5.2.7 Replace labyrinth gasket .....	35
5.2.8 Repair a faulty light (monitoring option) .....	36
5.2.9 Replace the fuse resistor (monitoring option) .....	37
5.2.10 Testing for Leaks .....	38
5.3 Material Handling Precautions: Fasteners .....	39
5.4 Bolt Torque Preventive Maintenance Schedule .....	40
<b>6.0 Troubleshooting</b> .....	<b>43</b>
6.1 Troubleshooting guide .....	43

<b>7.0 Parts</b> .....	<b>45</b>
7.1 Fixture code schema .....	45
7.2 Hardware kits .....	46
7.3 Exploded view and components .....	47
7.3.1 Exploded view .....	47
7.3.2 DTS, DTC, DFC Spare Parts .....	48
7.3.3 Screws .....	50
7.4 Standard toolkit .....	51
7.5 Additional accessories .....	52
<b>A.0 INTEROPERABILITY</b> .....	<b>53</b>
<b>B.0 CABLE LOSS</b> .....	<b>55</b>
<b>C.0 SUPPORT</b> .....	<b>57</b>
C.1 ADB SAFEGATE Website .....	57
C.2 Recycling .....	58
C.2.1 Local Authority Recycling .....	58
C.2.2 ADB SAFEGATE Recycling .....	58

# 1.0 Safety

## Introduction to Safety

This section contains general safety instructions for installing and using ADB SAFEGATE equipment. Some safety instructions may not apply to the equipment in this manual. Task- and equipment-specific warnings are included in other sections of this manual where appropriate.

## 1.1 Safety Messages

### HAZARD Icons used in the manual

For all HAZARD symbols in use, see the Safety section. All symbols must comply with ISO and ANSI standards.

Carefully read and observe all safety instructions in this manual, which alert you to safety hazards and conditions that may result in personal injury, death or property and equipment damage and are accompanied by the symbol shown below.



WARNING

Failure to observe a warning may result in personal injury, death or equipment damage.



DANGER - Risk of electrical shock or ARC FLASH

Disconnect equipment from line voltage. Failure to observe this warning may result in personal injury, death, or equipment damage. ARC Flash may cause blindness, severe burns or death.



WARNING - Wear personal protective equipment

Failure to observe may result in serious injury.



WARNING - Do not touch

Failure to observe this warning may result in personal injury, death, or equipment damage.



CAUTION

Failure to observe a caution may result in equipment damage.

### Qualified Personnel



Important Information

The term **qualified personnel** is defined here as individuals who thoroughly understand the equipment and its safe operation, maintenance and repair. Qualified personnel are physically capable of performing the required tasks, familiar with all relevant safety rules and regulations and have been trained to safely install, operate, maintain and repair the equipment. It is the responsibility of the company operating this equipment to ensure that its personnel meet these requirements.

Always use required personal protective equipment (PPE) and follow safe electrical work practice.

### 1.1.1 Introduction to Safety



#### CAUTION

##### Unsafe Equipment Use

This equipment may contain electrostatic devices, hazardous voltages and sharp edges on components

- Read installation instructions in their entirety before starting installation.
- Become familiar with the general safety instructions in this section of the manual before installing, operating, maintaining or repairing this equipment.
- Read and carefully follow the instructions throughout this manual for performing specific tasks and working with specific equipment.
- Make this manual available to personnel installing, operating, maintaining or repairing this equipment.
- Follow all applicable safety procedures required by your company, industry standards and government or other regulatory agencies.
- Install all electrical connections to local code.
- Use only electrical wire of sufficient gauge and insulation to handle the rated current demand. All wiring must meet local codes.
- Route electrical wiring along a protected path. Make sure they will not be damaged by moving equipment.
- Protect components from damage, wear, and harsh environment conditions.
- Allow ample room for maintenance, panel accessibility, and cover removal.
- Protect equipment with safety devices as specified by applicable safety regulations
- If safety devices must be removed for installation, install them immediately after the work is completed and check them for proper functioning prior to returning power to the circuit.

**Failure to follow this instruction can result in serious injury or equipment damage**

### Additional Reference Materials



#### Important Information

- IEC - International Standards and Conformity Assessment for all electrical, electronic and related technologies.
- IEC 60364 - Electrical Installations in Buildings.
- FAA Advisory: AC 150/5340-26 (current edition), Maintenance of Airport Visual Aid Facilities.
- Maintenance personnel must refer to the maintenance procedure described in the ICAO Airport Services Manual, Part 9.
- ANSI/NFPA 79, Electrical Standards for Metalworking Machine Tools.
- National and local electrical codes and standards.

### 1.1.2 Intended Use



#### CAUTION

##### Use this equipment as intended by the manufacturer

This equipment is designed to perform a specific function, do not use this equipment for other purposes

- Using this equipment in ways other than described in this manual may result in personal injury, death or property and equipment damage. Use this equipment only as described in this manual.

**Failure to follow this instruction can result in serious injury or equipment damage**



### 1.1.3 Material Handling Precautions: Storage



#### CAUTION

##### Improper Storage

Store this equipment properly

- If equipment is to be stored prior to installation, it must be protected from the weather and kept free of condensation and dust.

**Failure to follow this instruction can result in equipment damage**

### 1.1.4 Material Handling Precautions: Fasteners



#### DANGER

##### Foreign Object Damage - FOD

This equipment may contain fasteners that may come loose - torque properly.

- Only use fasteners of the same type as the one originally supplied with the equipment.
- Use of incorrect combination of gaskets, bolts and nuts can create severe damages to the product installation and create safety risk .
- You need to know what base the light fixture will be installed in, in order to chose the correct gasket, bolts and nuts.
- Bolt type, length, and torque value are determined by type of base, height of spacers used, and clamp force required in FAA Engineering Brief No 83 (latest revision).
- Due to the risk of bolts vibrating loose, do not use any type of washer with the fixing bolts (such as split lock washers) other than an anti-vibration washer. Anti-vibration washers as defined in FAA EB 83 (latest edition) must be used. For installations other than FAA, use the base can manufacturer's recommendations.
- Always tighten the fasteners to the recommended torque. Use a calibrated torque wrench and apply the recommended adhesive type.
- Obey the instructions of the adhesives necessary for the fasteners.

**Failure to follow these warnings may cause the fasteners to loosen, damage the equipment, potentially to loosen the equipment. This can lead to a highly dangerous situation of FOD, with potential lethal consequences.**



#### Note

To minimize the risk of errors, the ADB SAFEGATE Sales Representative will have information on which gasket goes with which base. This information is also provided in the product Data sheets, the User Manuals and the Spare Part Lists.



#### CAUTION

Use of incorrect combination of gaskets, bolts and nuts can create severe damages to the product installation and create multiple safety risks.

To obtain a safe and watertight installation the O-ring and retaining bolt stated in the document must be used.

You need to know what base the light fixture will be installed in, in order to choose the correct gasket, bolts and nuts.

**Failure to follow these cautions can result in equipment damage or aircraft FOD.**

### 1.1.5 Operation Safety



#### CAUTION

##### **Improper Operation**

Do Not Operate this equipment other than as specified by the manufacturer

- Only qualified personnel, physically capable of operating the equipment and with no impairments in their judgment or reaction times, should operate this equipment.
- Read all system component manuals before operating this equipment. A thorough understanding of system components and their operation will help you operate the system safely and efficiently.
- Before starting this equipment, check all safety interlocks, fire-detection systems, and protective devices such as panels and covers. Make sure all devices are fully functional. Do not operate the system if these devices are not working properly. Do not deactivate or bypass automatic safety interlocks or locked-out electrical disconnects or pneumatic valves.
- Protect equipment with safety devices as specified by applicable safety regulations.
- If safety devices must be removed for installation, install them immediately after the work is completed and check them for proper functioning.
- Route electrical wiring along a protected path. Make sure they will not be damaged by moving equipment.
- Never operate equipment with a known malfunction.
- Do not attempt to operate or service electrical equipment if standing water is present.
- Use this equipment only in the environments for which it is rated. Do not operate this equipment in humid, flammable, or explosive environments unless it has been rated for safe operation in these environments.
- Never touch exposed electrical connections on equipment while the power is ON.

**Failure to follow these instructions can result in equipment damage**

### 1.1.6 Maintenance Safety



#### DANGER

##### **Electric Shock Hazard**

This equipment may contain electrostatic devices

- Do not operate a system that contains malfunctioning components. If a component malfunctions, turn the system OFF immediately.
- Disconnect and lock out electrical power.
- Allow only qualified personnel to make repairs. Repair or replace the malfunctioning component according to instructions provided in its manual.

**Failure to follow these instructions can result in death or equipment damage**

### 1.1.7 Material Handling Precautions, ESD



#### CAUTION

##### Electrostatic Sensitive Devices

This equipment may contain electrostatic devices

- Protect from electrostatic discharge.
- Electronic modules and components should be touched only when this is unavoidable e.g. soldering, replacement.
- Before touching any component of the cabinet you shall bring your body to the same potential as the cabinet by touching a conductive earthed part of the cabinet.
- Electronic modules or components must not be brought in contact with highly insulating materials such as plastic sheets, synthetic fiber clothing. They must be laid down on conductive surfaces.
- The tip of the soldering iron must be grounded.
- Electronic modules and components must be stored and transported in conductive packing.

**Failure to follow this instruction can result in equipment damage**

### 1.1.8 Arc Flash and Electric Shock Hazard



#### DANGER

##### Series Circuits have Hazardous Voltages

This equipment produces high voltages to maintain the specified current - Do NOT Disconnect while energized.

- Allow only qualified personnel to perform maintenance, troubleshooting, and repair tasks.
- Only persons who are properly trained and familiar with ADB SAFEGATE equipment are permitted to service this equipment.
- An open airfield current circuit is capable of generating >5000 Vac and may appear OFF to a meter.
- Never unplug a device from a constant current circuit while it is operating; Arc flash may result.
- Disconnect and lock out electrical power.
- Always use safety devices when working on this equipment.
- Follow the recommended maintenance procedures in the product manuals.
- Do not service or adjust any equipment unless another person trained in first aid and CPR is present.
- Connect all disconnected equipment ground cables and wires after servicing equipment. Ground all conductive equipment.
- Use only approved ADB SAFEGATE replacement parts. Using unapproved parts or making unapproved modifications to equipment may void agency approvals and create safety hazards.
- Check the interlock systems periodically to ensure their effectiveness.
- Do not attempt to service electrical equipment if standing water is present. Use caution when servicing electrical equipment in a high-humidity environment.
- Use tools with insulated handles when working with airfield electrical equipment.

**Failure to follow these instructions can result in death or equipment damage**



## 2.0 About this manual

The manual shows the information necessary to:

- install
- carry out maintenance
- carry out troubleshooting

on the DTS / DTC light, in the manual referred to as the fixture.

### 2.1 How to work with the manual

1. Familiarize yourself with the structure and content.
2. Carry out the actions completely and in the given sequence.

### 2.2 Abbreviations and terms

Term or abbreviation	Description
AGL	Airfield Ground Lighting
C/L	Centre Line
DRC	AD-light Runway Centre Line light
DTC	AD-light Taxiway Centre Line light Curved section
DTS	AD-light Taxiway Centre Line light Straight section
DTZ	AD-light Touchdown Zone light
FAA	Federal Aviation Administration
Fastener	Generic term for an item that holds the fixture together or that holds the fixture on its mounting support, e.g. nut, bolt, washer
FOD	Foreign Object Debris
HPI	Commercial name for an ADB type of 8" shallow base
ICAO	International Civil Aviation Organisation
IEC	International Electrical Committee
ISO	International Standardization Organisation
Mounting support	A piece of equipment permanently installed in the ground, on which the fixture is installed. It can be a shallow or deep base, with or without adapter ring.
PCB	Printed Circuit Board
Toe-in	The toe-in angle is the angle the beam of light makes with the longitudinal axis of the runway or taxiway.
UNC	Unified Thread Standard



## 3.0 Description

### 3.1 Overview

You can find a complete overview of the fixture in all available versions in chapter 7.

### 3.2 LED Taxiway Centerline, Stop Bar and Holding Position Inset Light

#### Compliance with Standards

<b>ICAO:</b>	Annex 14, Vol. 1, par. 5.3.17, 5.3.20 and 5.3.21
<b>FAA:</b>	L- 852(L) Series AC 150/5345-46 and FAA Engineering Brief No. 67
<b>T/C:</b>	Transport Canada TP 312, par. 5.3.16, 5.3.18 and 5.3.19
<b>NATO:</b>	STANAG 3316

#### Uses

- ICAO & T/C**
- DTS/DTC/DFS taxiway lights are used in category I, II & III as:
    - Taxiway Centerline on straight and curved section and on rapid exit taxiways
    - Stop bar
    - Intermediate holding position lights
    - De-/anti-icing facility exit lights
    - Apron lead-in lights
- FAA L-852C(L)**
- Taxiway Centerline on straight section and clearance bar in category III applications, <1,200 L RVR
- FAA L-852K(L)**
- Taxiway Centerline on curved sections in category III applications, <1,200 L RVR

#### Features

- The evolution of the most successful LED lights in the world, fully adapted to the characteristics of an LED lighting source
- Very low energy consumption (typically 10 W for a single-plug bidirectional light, and 8 W per side for a dual-plug light, compared to 40 W for tungsten halogen lights)
- Greatly reduced maintenance: calculated MTBF of 56,000 hours at 6.6A
- Increased traffic efficiency and availability of the taxiways thanks to the reduction of maintenance
- Optimum and homogeneous light distribution along the lights installed on the same taxiway
- High discrimination between functions thanks to the saturated colors, their stability at the different brightness steps and under all viewing angles
- Full compatibility with existing airfield lighting series circuits. No need to replace the CCRs, series transformers, or cables
- Fully dimmable lights, respecting the response curve of traditional halogen lights. Operates on the full range of 2.8 A to 6.6 A.
- Installation on the same bases as 8 inch tungsten-halogen lights for a straightforward replacement.
- Substantial investment reduction for new installations, resulting from a lower installed load
- Very low working temperature, ensuring longer component life

## Description

- Rugged lightning protection complies with ANSI/IEEE C62.41-1991 Location Category C2 given in FAA Eng. Brief 67. Category C2 is defined as a 1.2/50 $\mu$ S – 8/20  $\mu$ S combination wave, with a peak voltage of 10,000 V and a peak current of 5,000 A.
- When turned on, light rise time is low. The light is perfectly adapted for any incursion protection system.
- Optional monitoring function of the individual light source. In case of a defect, the LED light automatically disconnects from the secondary side of the isolation transformer, resulting in an open circuit condition.
- Environment-friendly, precision-cast aluminum alloy top, intermediate and bottom covers
- Corrosion-resistant stainless steel hardware. Use of Torx screws ensures ease of maintenance.

DTS/DTC/DFS lights are part of a complete range of LED in-pavement lights, featuring innovative characteristics, as a leverage for:

## Reliability

- Additional watertightness barriers, protecting both the electronics and the LEDs in case of accidental water ingress, along the prism or the gaskets as well as along the cables
- Prisms of small dimensions installed in a deep optical channel with no negative window slope: optimal protection against rubber deposit, scratches and shocks.

## Modularity

- High commonality of components between the various models. Stock management is easier
- Field customization according to the application is straightforward: a light can be transformed into another model by swapping components
- Same tools and same procedures to maintain the whole range, reducing the risk of mistakes and time loss.

## Maintenance friendliness

- Maintenance-friendly: components subject to wear or damage like prisms and cables can easily be replaced. Neither sealing compounds nor resin are required
- Innovative design of the cable entry, permitting replacement without the need to open the light. This eliminates the risk of water leakage due to a pinched cable.
- Reduced number of components for maintenance simplicity
- Pressure-release plug for water-tightness testing of fixture after overhaul.

**Available version for use in Advanced Power Supply System (APS)**

- Further reduction of the power consumption: only 3 W per side
- Simplification of the electronics increases MTBF and reduces maintenance time and cost
- Allows airports to reuse the existing series circuit
- For detailed information on the APS system, please refer to leaflet N° 3010

**Electrical Supply**

2.8A-6.6 A, through a 20/25 W isolation transformer.

DTS/DTC/DFS lights have been designed to work with any IEC or FAA compliant transformer up to 100 W without affecting the performances or the lifetime of the light or the transformer. However, using a non-matched transformer will reduce its efficiency.

Fixture Type	Fixture Load	Isolation Transformer	Isol. XF Load	CCR Load
<b>Bidirectional, 1 plug</b>				
DTS / DTC	14 VA	20/25 W	11 VA	25 VA
DFS	16 VA	20/25 W	9 VA	25 VA



Fixture Type	Fixture Load	Isolation Transformer	Isol. XF Load	CCR Load
<b>Unidirectional or bidirectional, 2 plugs Load per side</b>				
DTS / DTC	11 VA	20/25 W	11 VA	22 VA
DFS	11 VA	20/25 W	10 VA	21 VA

## Design

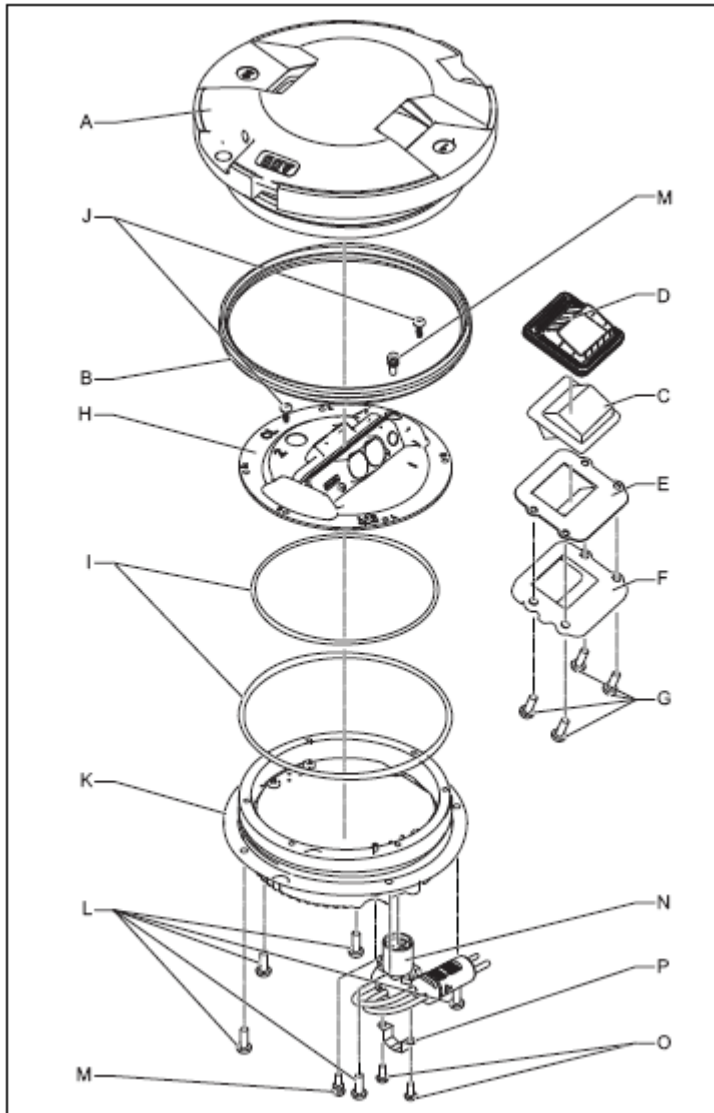

## Construction

A	Aluminum alloy upper cover
B	Labyrinth gasket
C	Prism (1 or 2)
D	Prism gasket (1 or 2)
E	Prism protection plate
F	Prism bracket
H	Optical assy, including LEDs

Description

I	O-ring gaskets
K, L	Aluminum alloy inner cover assy, with transformer(s) and printed circuit board
N	Pressure release plug with O-ring
O	Replaceable cable lead with molded FAA L-823 style 6 plug (1 or 2)

Toe-in Color Coding

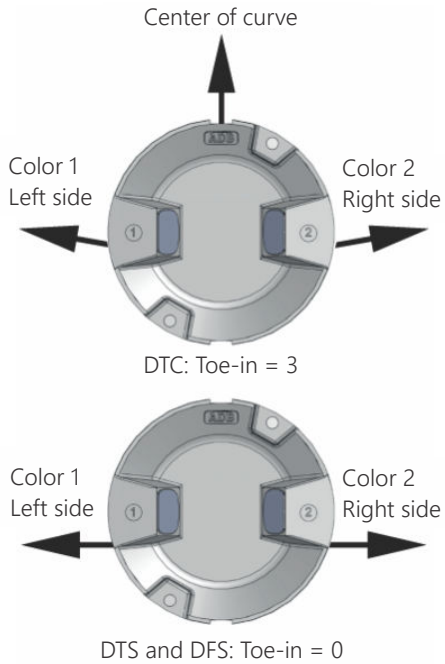

Photometric Performances

Application ICAO	Application FAA	Main beam aperture		Color	ICAO Main beam average intensity (cd) (typical value)	FAA Horizontal / Vertical average intensity (cd) (typical value)
		Horiz. (°)	Vert. (°)			
Straight section, narrow beam	L-852C	-3.5 tot +3.5	1 to 8	Green	318	352 / 322
				Yellow	474	513 / 478
				Red	376	N.A.
Straight section, wide beam	N.A.	-10 tot +10	1 to 8	Green	317	N.A.
				Yellow	469	N.A.
				Red	378	N.A.
Curved section	L-852K	-3.5 to +35	1 to 10	Green	194	208 / 209
				Yellow	188	210 / 190
				Red	160	N.A.
Enhanced light for rapid exit	N.A.	-10 tot +10	1 to 8	Green	1072	N.A.
				Yellow	1189	N.A.

## Photometric Curves

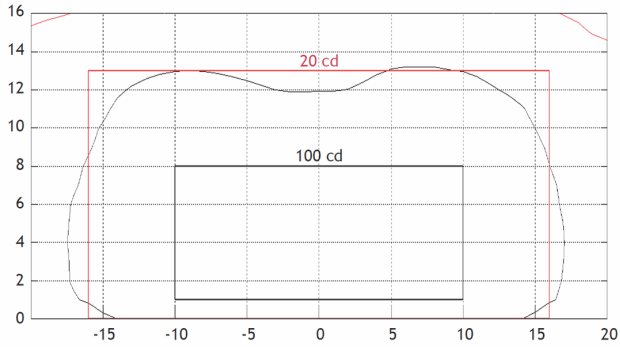

Photometry - ICAO taxiway straight / FAA L-852C  
(green light)

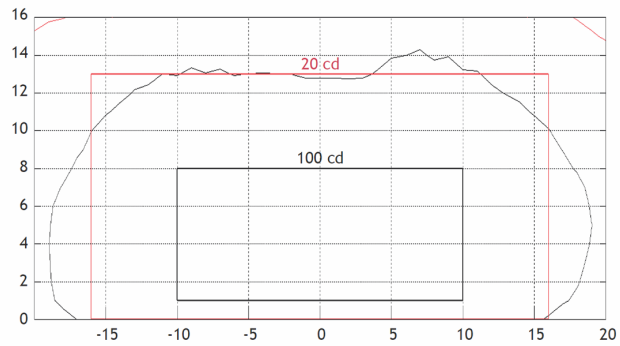

Photometry - ICAO taxiway straight / FAA L-852C  
(yellow light)

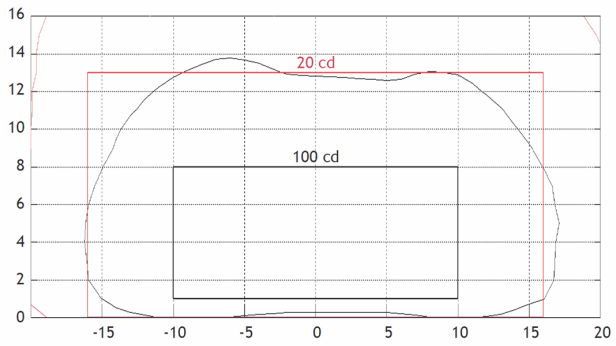

Photometry - ICAO taxiway straight for rapid exit  
(green light)

Description

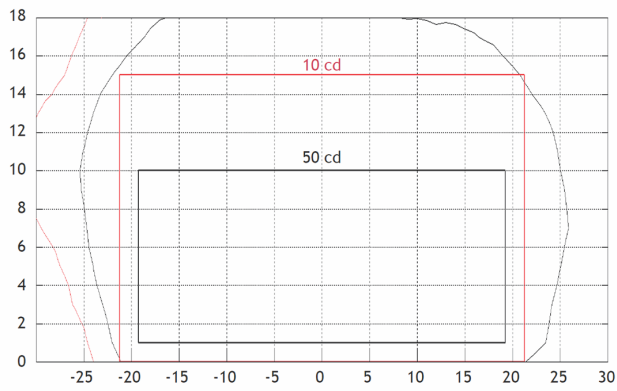

Photometry - ICAO taxiway curved / FAA L-852K (green light)

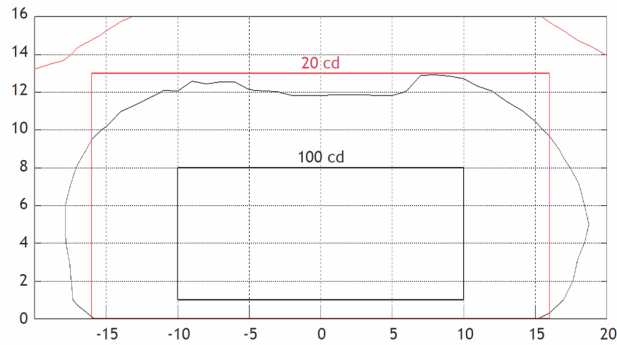

Photometry - ICAO stop bar straight (red light)

Additional photometric curves can be found in the Product Center on our website ([www.adbsafegate.com](http://www.adbsafegate.com)) under the "Photometric Data" tab, or by contacting your local ADB SAFEGATE representative.

Dimensions

<b>8-inch fixture:</b>	
Outside diameter	202 mm (7.97 in)
Overall height	78.4 mm (3.1 in)
<b>8-inch shallow base:</b>	
Outside diameter	230 mm (9.06 in)
Depth	115 mm (4.53 in)

Packaging

<b>8-inch fixture:</b>	
In cardboard box	210 × 210 × 100 mm (8.27 × 8.27 × 3.94 in)
Weight with packing	3.9 kg (8.6 lb)
Weight without packing	3.7 kg (8.2 lb)
<b>8-inch shallow base:</b>	

In cardboard box	230 × 230 × 150 mm (9.06 × 9.06 × 5.91 in)
Weight with packing	2.8 kg (6.2 lb)
Weight without packing	2.6 kg (5.7 lb)

### 3.3 APS version

The APS versions of the fixtures are specifically designed for use with the ADB Advanced Power Supply (APS) system. See [Fixture code schema](#) for the codes of the APS versions.



#### WARNING

Do not use an APS version of the fixture in a series circuit with a traditional 6.6A Constant Current Regulator (CCR).

### 3.4 Identification on the fixture

#### 3.4.1 Top

- An embossing (A) 1 and 2 indicates side 1 and 2; A
- Coloured dots (B) at delivery give an indication of the colour of the light at that side.

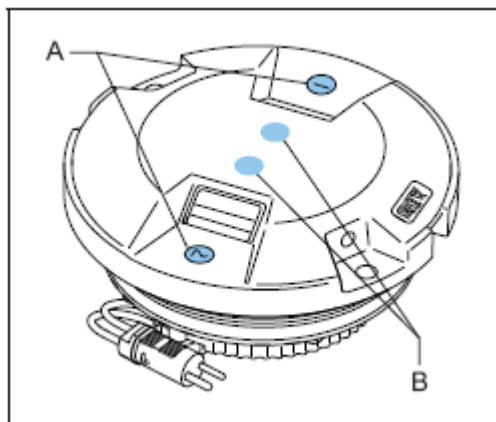

#### 3.4.2 Bottom

A type plate, where:

- **A**: the fixture code.
- **B**: the toe-in:
  - 1: points in the direction of the centreline or the centre of the curve.
  - •: no toe-in.
- **C**: the colour of the light at side 1 and 2.
  - E.g. G/Y means green at side 1, Yellow at side 2.
- **D**: Serial number.
- **E**: Article number of the inner cover assy.

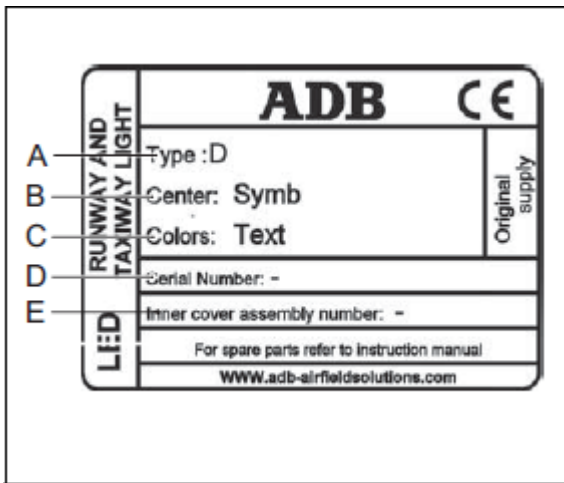

**i** Note

- For an overview of all fixture colour and APS version codes see [Fixture code schema](#).
- If you modify the fixture, it is your responsibility to update the identification. ADB can supply modification stickers: see [Exploded view and components](#).

## 4.0 Installation



### WARNING

Read the instructions in their entirety before starting installation.

This section provides installation instructions for the DTS/DTC/DFS LED light fixtures.

This section provides instructions for installing the in-pavement lights. Refer to airport project plans and specifications for specific installation instructions. The installation must conform to the applicable sections of the National Electric Code and local codes.

### 4.1 Overview of Sequence of Work

- Electrical contractor locates new light bases and interconnecting conduit trench, and excavates for light base bottom section by saw cutting or core drilling. Electrical contractor prepares subgrade and stone subbase, sets bottom section with rebar, rigid steel conduit stubs, drain, and pours high early strength concrete-encasement excavation. Electrical contractor shall record can locations and elevations of mud plate after concrete-encasement.
- Electrical contractor excavates conduit trench, installs rigid steel and fittings, backfills conduit trench with high early strength concrete.
- General contractor prepares and installs concrete pavement. Electrical contractor makes a pilot core to find mud plate center point indent before final core-drilling.
- Electrical contractor core-drills concrete pavement. Electrical contractor installs top section, y-flange ring, space and lighting fixture, and pours epoxy joint sealer. Provide space for adjustment with spacers, maximum number of spacers shall be 3.
- See specific details as shown in FAA AC 150/5340-30 (current edition).

### 4.2 Installation Overview

#### On a shallow base.

The 8" dia. base is secured in the pavement by means of resin. Correct positioning and leveling are obtained with a jig with sighting telescope. Wires between the light and the series transformer are installed either in saw cuts in the pavement filled with resin or in pipes in the lower concrete layers. Mounting on existing or new, larger diameter bases, is made possible by means of dedicated adapter rings.

**Figure 1: Installation on 8" shallow base**

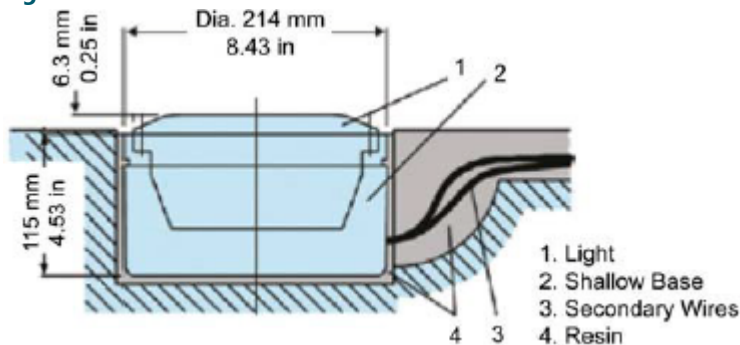

#### On a FAA L-868B size B steel base.

The 8" dia. light is mounted in an 8" to 12" dia. snow plow or adapter ring bolted onto the base. The 12" fixture is directly mounted without a separate ring. The bases are interconnected by means of conduits protecting the cables. See FAA AC 150/5340-30 for additional design guidance on deep base cans. The series transformer is installed under the light or in a separate pit. See data sheet A.05.120 or DS2012 for more information on base cans.

## 4.3 INTEROPERABILITY

### Top cover versions

---



#### Note

Please check interoperability matrix for information on torque values and compatibility towards different bases.

---



## 4.4 Typical L-868 Assembly

Figure 2: Diagram of the Fixture Installed in a 1-Piece Base Can

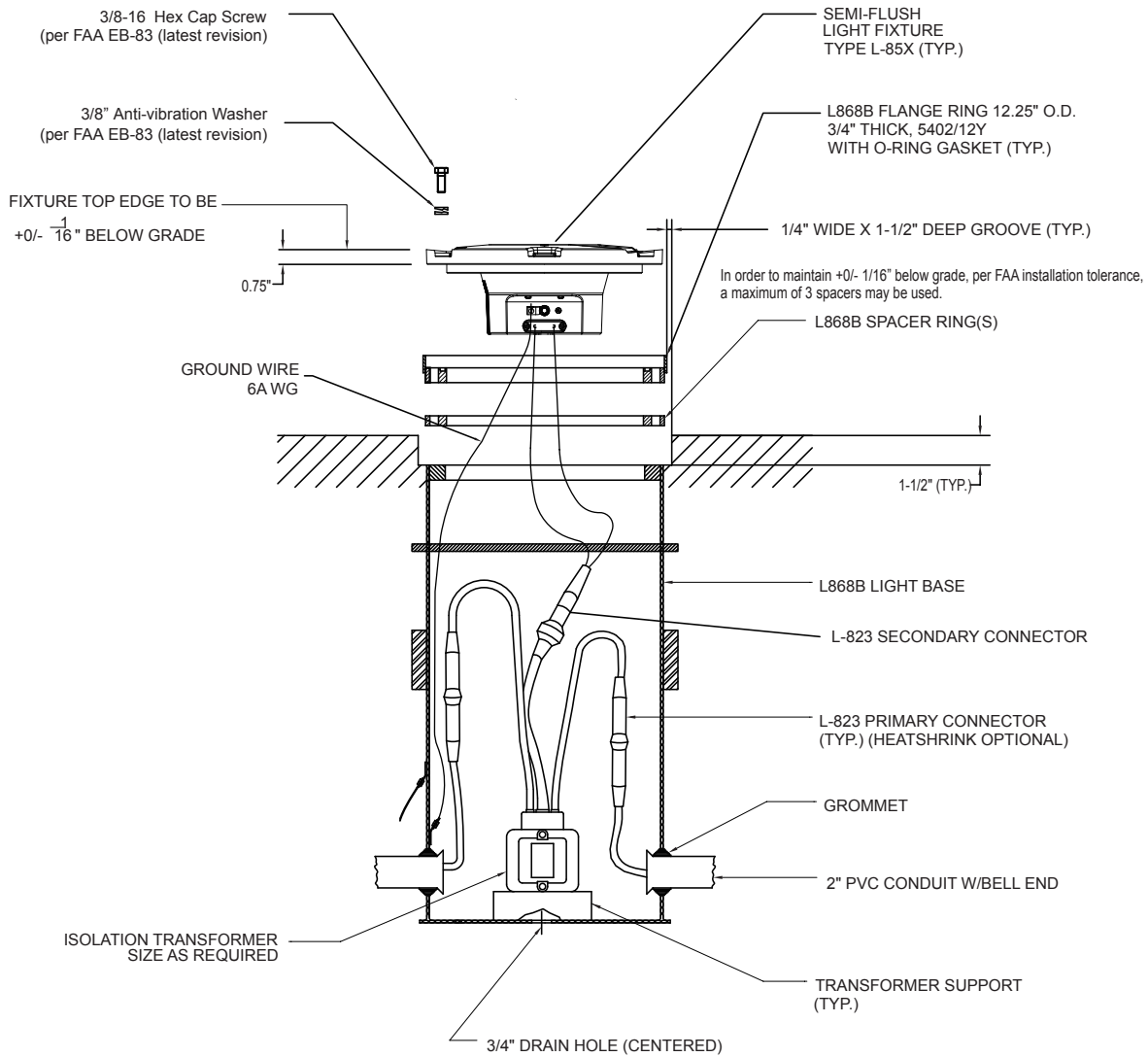

1. Torque according to: FAA EB-83 (latest revision).

Figure 3: Anti-vibration washer example

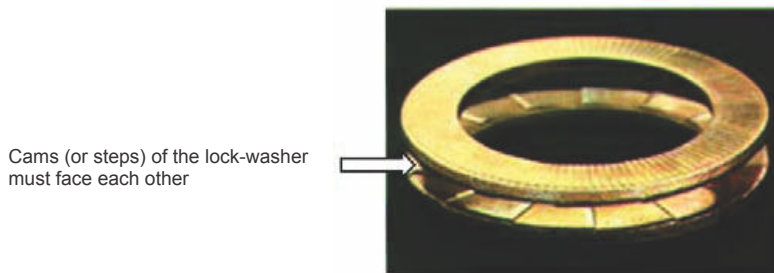



### **CAUTION**

Per FAA AC 150/5340-30, Chapter 10, and FAA Engineering Brief No 83 (latest revision), it is extremely important that other types of washers, such as split washers, must not be used. Failure to use properly installed anti-vibration lock washers will cause mounting bolts to become loose. The cams (or steps) of each half of the lock washer must face each other.

---

## **4.5 Safety Considerations**

Read the installation section of all system component manuals before starting these steps. A thorough understanding of system components and their requirements will promote safe and efficient installation. See FAA AC 150/5340-30, Design and Installation Details for Airport Visual Aids, and site plans and specifications for field installation of runway and taxiway in-pavement lights.

---



### **DANGER**

Failure to follow these safety procedures can result in personal injury or death.

- Allow only qualified personnel to install ADB SAFEGATE and auxiliary equipment. Use only approved equipment. Using unapproved equipment in an approved system may void FAA approvals. Observe and follow the safety instructions in this document and all other related documentation.
  - Make sure all equipment is rated and approved for the environment where it is being used.
  - Follow all instructions for installing components and accessories.
  - Install all electrical connections in compliance with local and national codes and regulations.
  - Use only electrical wire of sufficient gauge and insulation to handle the rated current demand. All wiring must meet local and national codes.
  - Route electrical wiring along a protected path. Make sure it will not be damaged by moving equipment.
  - Protect components from damage, wear and harsh environmental conditions.
  - Allow ample clearance for maintenance, panel accessibility and cover removal.
  - Protect equipment with safety devices as specified by applicable safety regulations.
  - If safety devices must be removed for installation, reinstall them immediately after the work is completed and check them for proper functioning.
  - The cord set must be protected prior to installation.
- 

## **4.6 Photobiological safety**



### **CAUTION**

Photobiological safety conforming with IEC 62471

RISK GROUP 0 or 1: Optical radiation emitted from LED lights may be harmful to the eyes. Do not stare with at the light source with bare eyes at a fixture operating at high intensity. Use protection goggles or similar protection method.

Goggles with a transmission factor not higher than 5% in the 400-530 nm band have been tested and provide adequate protection.

---

## **4.7 Verify Input Requirements and Equipment Needed**

The In-pavement light fixture is designed for connection to a 6.6A or 20A series lighting circuit via an L-830 (60 Hz) or L-831 (50 Hz) isolation transformer.

---

Make sure you have the necessary tools and materials ready for installation (not supplied). Also consider other tools that might be needed based on site-specific conditions.

**Table 1: Suggested Tools and Materials for Installation and Repair**

Qty.	Description	Qty.	Description
1	Torque wrench	1	Set of screwdrivers, one with 3/8" (9.525mm) minimum blade width
1	Alignment jig		
1	Diamond-faced core drill	As needed	Silicone grease
1	Diamond-faced saw, 3/8" (9.525mm) thick	As needed	Joint sealing filler
1	Crimping tool	1	Pressure test fitting assembly
1	Small water suction pump	As needed	Dow Corning Molykote® 3452 or equal (P/N 67A0095) - used on top cover prism seal
2	Eyebolts, 3/8 inch (9.525mm) diameter		
1	Lifting rod, 16 inches (406mm) long	As needed	Novagard® Silicone Versilube® G322L™ (P/N 67A0009) - used on O-ring between top cover and inner pan assembly; also may be applied to four nipples of inner pan assembly to install optical assembly
1 or 2	L-830 / L-831 isolation transformer		
1	Set of fiber brushes		
1	Set of socket wrenches, 1/2" (12.7mm) drive		

## 4.8 Unpacking the Unit

To reduce the possibility of damaging the light assembly, unpack the RELIANCE light fixtures at the installation site. If damage to any equipment is noted, file a claim form with the carrier immediately.

When receiving the light fixture, open the box and verify that the characteristics of the light fixture correspond to the design requirements, such as type, color etc. When installing an IQ0 light fixture where the function is to be activated at a later stage, make sure to register product information, such as PID/SN and position of the light fixture in, for example, a site documentation table. The information is required for remote activation and administration of IQ functionality from a substation.

## 4.9 Inspect on delivery

1. Inspect all packings for visible damage.
2. Open every damaged box and inspect the contents for damage.
3. Immediately fill a claim form with the carrier if any fixture is damaged.
4. Store the fixture in its original packing in a protected area.



### Note

If damage to any equipment is noted, file a claim form with the carrier immediately.



### WARNING

Do not damage the cable insulation.



### CAUTION

Do not unpack the fixture before it is at the installation site to avoid damage due to transportation and handling.

## 4.10 Store

Store the fixture in its original packing in a protected area. Indoor storage:

- Storage temperature: 14°F to 122°F (-10°C to +50°C).
- Humidity: <95% non condensing.

For long storage periods (longer than one year), we recommend to energize the LED lights once a year at nominal intensity (6.6 Amps) for 20 minutes.

## 4.11 Installation on L-868 Base

The light assembly is shipped complete, and is ready for installation.

To install the fixture on an L-868 base, see FAA AC 150/5345-30 and the project site-specific plans and specifications for details on L-868 base installation.

---



### Note

Mounting bolts are not supplied with the fixture. Mounting bolts and anti-rotation lock washers are normally supplied with the base can spacer or flange ring. If a flange ring is used, the bolt length is 1-1/4 inch (32mm) plus the thickness of the flange ring.

---

Also read the following guidelines:

1. Clean the base receptacle. Make sure the base receptacle is completely clean and dry. The mating surfaces must be clean and free of foreign particles.
2. If, present, fit an appropriate lifting tool into the two threaded holes, which are located 180° apart in the cover.



The lifting tool can be made from two 1/2 x 13 eyebolts (1-inch ID) and a 1/2-inch diameter, 16-inch (406mm) long rod or pipe inserted through the eyebolts.

---



### CAUTION

Never hold the light fixture by the wires. Doing so may damage the insulation, break the waterproof seal and cause insulation faults and water leakage.

---

3. Carry the light assembly to the base.
  4. Place the light assembly next to the opening in the L-868 base so that the L-823 connector can be connected with the mating receptacle from the L-830 or L-831 isolation transformer in the base. Make sure that the connection is solid and secure. Refer to the Electrical Supply section of the User manual for required isolation transformers.
  5. Make sure items such as spacers, shims and gaskets are installed on the light base as indicated on site plans, specifications and drawings.
  6. Position the light assembly over the L-868 base and set it onto the base. Align the light according to FAA AC 150/5345-30 and project plans and specifications. Remove the eyebolts and lifting rod.
- 



### CAUTION

Ensure that the cord set wires are NOT pinched between the base can and the fixture. Pinched wires can cause water to be drawn inside the fixture.

---

---

7. If present, lubricate the labyrinth gasket with water. soap may be added to the water (8" only).

---



**CAUTION**

Do not use silicon or any other type of grease. Avoid the use of soap that contains silicon or glycerin.

---

8. Attach the six fixing bolts and anti-vibration washers. [See FAA EB-83 (latest revision)]

---



**CAUTION**

Due to the risk of bolts vibrating loose, do not use any type of washer with the fixing bolts (such as split lock washers) other than an anti-vibration washer. Anti-vibration washers as defined in FAA EB-83 (latest revision).

---

9. Turn on the power to determine whether the fixture will illuminate. Operate for a minimum of five minutes.

## 4.12 Torquing and Installation Guidance for In-pavement Fixtures

In-pavement fixtures must be installed according to the plans and specifications; the applicable regulatory guidance; and the following guidance. The importance of using the proper fixture clamping components and bolt torque to minimize the risk for fixture failure or loosening of clamping components cannot be overemphasized. Refer to FAA Engineering Brief No 83 (latest revision) for torque and installation guidelines for this fixture.

Also see our Product Center at [www.adbsafegate.com](http://www.adbsafegate.com).

---



**CAUTION**

Read installation instructions in their entirety before starting installation.

- Failure to follow the installation guidance could result in bolt loosening or bolts breaking off, resulting in catastrophic failure of the fixture and/or the mounting system components.
  - Failure to follow these warnings may result in serious injury or equipment damage.
-

## 4.13 Shallow base can installation

Shallow base cans may be non-load bearing or load bearing depending on location or fixture application. Following are specific requirements to insure that an either an elevated or an in-pavement fixture is properly installed.

---



### CAUTION

Read installation instructions in their entirety before starting installation.

Fasteners:

- Make sure the power is OFF when you install or remove any fixture.
- Only use fasteners of the same type as the one originally supplied with the mounting support. See Base O-ring and Bolt Selection.
- Always tighten the fasteners to the recommended torque. Use a calibrated torque wrench and apply the recommended adhesive type.
- If this is not the case, this may cause the fasteners to loosen, damage the fixture, potentially to loosen the fixture. This can lead to a highly dangerous situation of FOD, with potential lethal consequences.
- Obey the instructions of the adhesives necessary for the fasteners.
- Only install the fixture on mounting supports:
  - That ADB Safegate has approved;
  - That are installed according to the Instruction Manual of the mounting support.
- Failure to do so can result in a highly dangerous situation of FOD, with potential lethal consequences.

Failure to follow these warnings may result in serious injury or equipment damage.

---



### CAUTION

Proper Operation:

- The fixture is supplied from a 6.6 A series circuit;
  - The series circuit is powered by a Constant Current Regulator that complies with IEC 61822;
  - The transformer is an AGL series transformer that complies with IEC 61823.
  - The power of the series transformer shall not exceed 200 W, for versions with the monitoring option.
  - The mounting support is correctly earthed. Failure to do so will void the warranty for all damages that occur as a result of voltage surges.
  - Never hold the fixture by the cable leads. This can damage the insulation, break the waterproof seal and cause insulation faults and water leakage.
- 



### Note

See the Instruction Manual of the mounting support for instructions on how to earth the mounting support.

---

### 4.13.1 Installation on a Shallow Base

Installing the light fixture on a shallow base involves preparing the pavement recess and wireways, then installing the light fixture on a shallow base.

See FAA AC 150/5345-30 and the project site-specific plans and specifications for details on shallow base installation.

---

Also follow the applicable instructions in the previous section, when connecting, installing and powering the fixture.

**Figure 4: Example of a Shallow Base Installation**

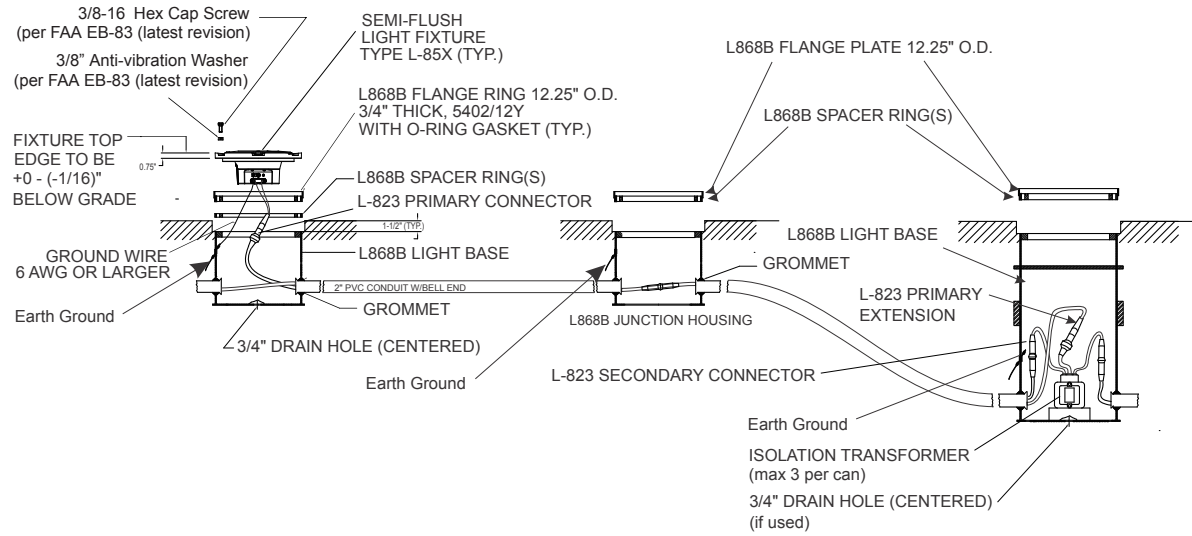

1. Torque according to: FAA EB-83 (latest revision).

**Figure 5: Anti-vibration washer example**

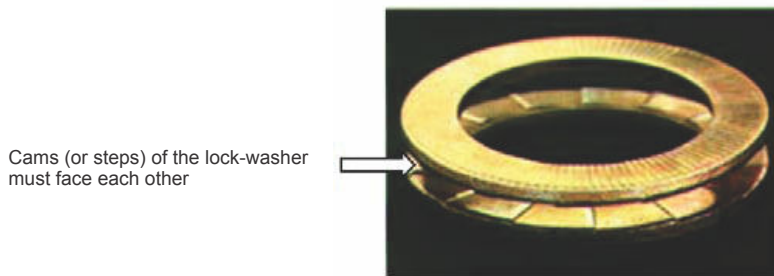

**CAUTION**

Per FAA AC 150/5340-30, Chapter 10, and FAA Engineering Brief No 83 (latest revision), it is extremely important that other types of washers, such as split washers, must not be used. Failure to use properly installed anti-vibration lock washers will cause mounting bolts to become loose. The cams (or steps) of each half of the lock washer must face each other.





## 5.0 Maintenance

Maintenance personnel must refer to the maintenance procedure described in the ICAO Airport Services Manual, Part 9, Airport maintenance practices and in FAA Advisory Circular N° AC150/ 5340-26, chapter 45, section 4.



### CAUTION

**Do not carry out any action on the fixture unless you have read and understood all the information in the Safety Section.**

**Make sure that the power to the series circuit is OFF when you carry out maintenance.**

### 5.1 Preventive maintenance schedule

Frequency	Check	Action
Daily	For low light output according to ICAO annex 14	<ul style="list-style-type: none"> <li>• If the prism is dirty, clean the prism.</li> <li>• If the prism is not dirty,               <ul style="list-style-type: none"> <li>• replace the fixture. See <a href="#">chapter 4</a>.</li> <li>• and replace the faulty component in the workshop. See <a href="#">Troubleshooting guide</a>.</li> </ul> </li> </ul>
Monthly	Visually for condensation on inner side of the prisms (presence of moisture or water)	<ul style="list-style-type: none"> <li>• Replace the fixture. See <a href="#">chapter 4</a>.</li> <li>• and replace the faulty component in the workshop. See <a href="#">Troubleshooting</a>.</li> </ul>
	For failed fixture	<ul style="list-style-type: none"> <li>• Replace the fixture. See <a href="#">chapter 4</a>.</li> <li>• and replace the faulty component in the workshop. See <a href="#">Troubleshooting</a>.</li> </ul>
Half-yearly	For presence of water in the mounting support	<ul style="list-style-type: none"> <li>• Remove all water from the mounting support.</li> <li>• Dry all parts of the fixture.</li> <li>• Replace all corroded parts.</li> <li>• Remove the cause of the water ingress.</li> </ul>
After snow removal	For damaged fixture.	<ul style="list-style-type: none"> <li>• Replace the total fixture. See <a href="#">chapter 4</a>.</li> <li>• Use a power broom to remove the snow near the fixture, if practical.</li> <li>• Follow the recommended snow removal techniques described in FAA AC 150/5200-30 to avoid or at least to reduce damage to the fixture.</li> </ul>

### 5.2 Part replacement



### CAUTION

- **Only use fasteners of the same type as the one originally supplied with the fixture.**
- **Always tighten the fasteners to the recommended torque. Use a calibrated torque wrench.**

**If this is not the case, this may cause the fasteners to loosen, damage the fixture, potentially to loosen the fixture. This can lead to a highly dangerous situation of FOD, with potential lethal consequences.**

**Never hold the fixture by the cable leads. This can damage the insulation, break the waterproof seal and cause insulation faults and water leakage.**



## Note

For the correct replacement parts, see [Fixture code schema](#) and [Exploded view and components](#).  
For the correct standard tool kit, see [Standard toolkit](#).

---

### 5.2.1 How to replace parts - general procedure

1. Remove the fixture. See [§ 4.4](#).
2. Replace the part.
  - Upper cover assy. See [Replace upper cover assy](#).
  - Prism. See [Replace prism](#).
  - Optical assy. See [Replace optical assy](#).
  - Inner cover assy. See [Replace inner cover assy](#).
  - Repair a faulty light. See [Repair a faulty light \(monitoring option\)](#) (for monitoring option only).
  - Replace the fuse resistor. See [Replace the fuse resistor \(monitoring option\)](#) (for monitoring option only).
  - Cable lead. See [Replace cable lead](#).
  - Labyrinth gasket. See [Replace labyrinth gasket](#).
3. Make sure that a waterproof test is carried out.  
See [§ 5.3](#).
4. Carry out a fixture operation test.  
See [§ 5.4](#).
5. Install the fixture.  
See [§ 4.3](#).

### 5.2.2 Replace upper cover assy

---



## CAUTION

**Always dispose of the gaskets and the screws when you disassemble the upper cover assy.**

---

#### Parts

- Upper cover assy
- Inner cover screws
- Gasket of the pressure release screw

#### Tools:

- Lubricant A. See [Standard toolkit](#).

#### Disassemble -

1. Remove the pressure release screw (A).
2. Dispose of the gasket of the pressure release screw.
3. Remove the inner cover screws (B).
4. Dispose of the inner cover screws.
5. Remove the upper cover assy (C).

**i Note**  
Put a screwdriver in the notches (D).

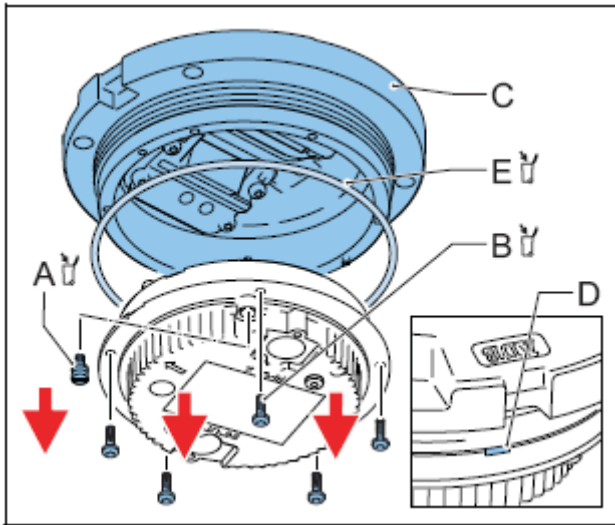

6. Remove the gasket (E).

7. Dispose of the gasket.

*Assemble*

*Prepare*

8. Make sure that all parts are clean.

9. Pay special attention to the parts where the gasket must fit.

*Assemble*

10. Lubricate the new gaskets.

*Use lubricant A.*

- Gasket (A);
- Gasket of the pressure release screw (D);

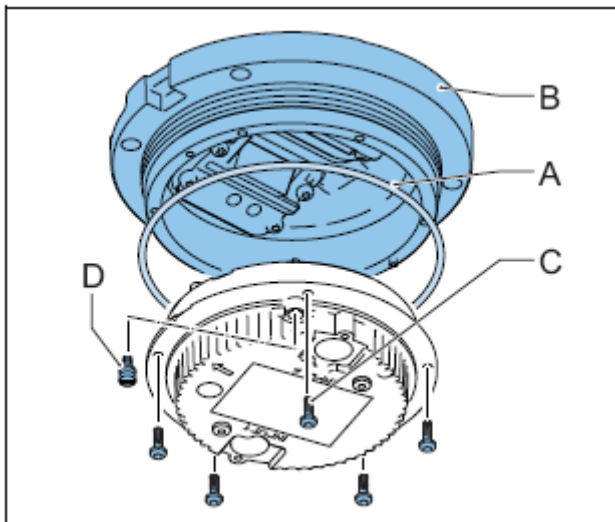

11. Install the new gasket (A).

12. Install the upper cover assy (B).
13. Install the new inner cover screws (C).  
See [Screws](#) (torque).
14. Carry out a waterproof test.  
See [§ 5.3](#).
15. Install the new gasket of the pressure release screw (D).
16. Install the pressure release screw.  
See [Screws](#) (torque).

### 5.2.3 Replace prism

---



#### CAUTION

**Always dispose of the gaskets and the screws when you disassemble the prism.**

---

#### Parts

- Prism
- Prism gasket
- Prism screws.

#### Disassemble

1. Remove the upper cover assy.  
See [Replace upper cover assy](#).
2. Remove the prism screws (A).
3. Dispose of the prism screws.
4. Remove the prism bracket (B).
5. Remove the prism protection plate (C).
6. Remove the prism (D).
7. Remove the prism gasket (E)
8. Dispose of the prism gasket.

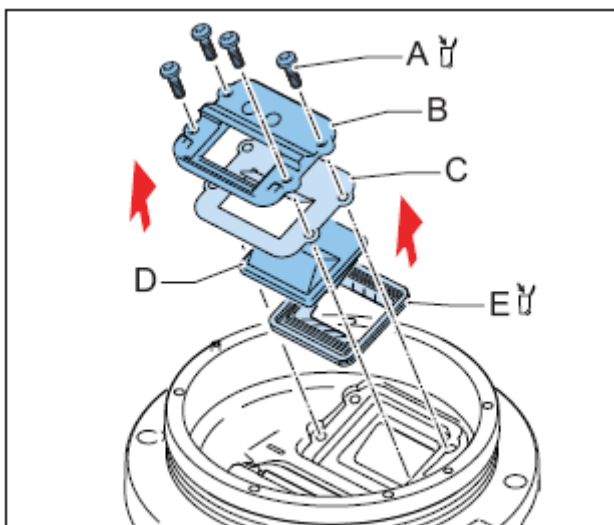

#### Assemble

#### Prepare

9. Make sure that all parts are clean.
10. Pay special attention to the parts where the gasket must fit.

*Assemble prism*

11. Install a new prism gasket (A).
12. Install a new prism (B).  
Tilt the prism a little and press the prism firmly.
13. Make sure the prism and the prism gasket are correctly in position.  
If it is not the case re-install the new prism and prism gasket.
14. Make sure you installed the correct prism and prism gasket.
15. Clean the surface of the new prism with a methanol moist cloth.
16. Install the prism protection plate (C).
17. Install the prism bracket (D).
18. Install but do not tighten the new prism screws (E).
19. Tighten the prism screws crosswise.  
See [Screws](#) (torque).
20. Install the upper cover assy.  
See [Replace upper cover assy.](#)

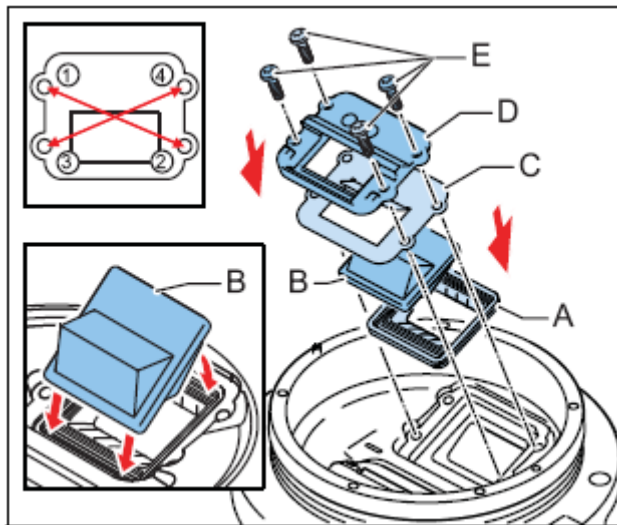

### 5.2.4 Replace optical assy



#### CAUTION

**Always dispose of the gaskets and the screws when you disassemble the optical assy.**

*Parts*

- Optical assy
- Optical assy screws.
- Gasket for optical assy
- Gasket of the pressure release screw

### Tools

- Lubricant A. See [Standard toolkit](#).

### Disassemble

1. Remove the upper cover assy.  
See [Replace upper cover assy](#).
2. Remove the pressure release screw (A).
3. Dispose of the gasket of the pressure release screw.
4. Remove the optical assy screws (B).
5. Dispose of the optical assy screws.
6. Remove the optical assy (C).

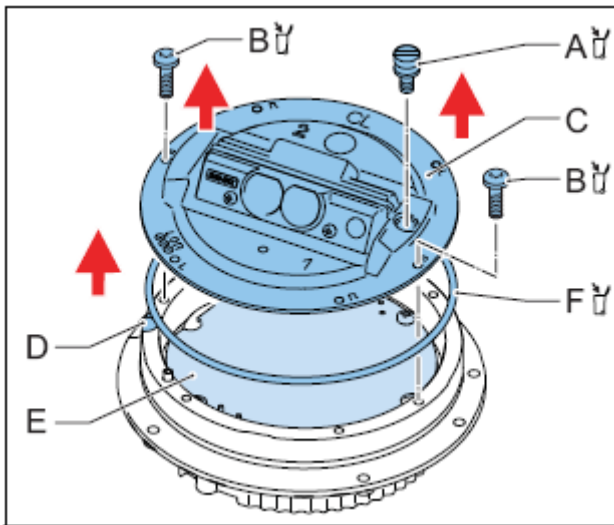

### CAUTION

The optical assy is connected to the PCB. If you pull too hard, you can E damage the PCB.

---



### Note

Put a screwdriver in the notches (D).

---

7. Disconnect the wires from the optical assy to the PCB (E).

*Pull the wires, not the connector.*

8. Remove the gasket (F).
9. Dispose of the gasket.

### Assemble

#### Prepare

10. Make sure that all parts are clean.
11. Pay special attention to the part where the gasket must fit (A).
12. Lubricate the new gasket (B).  
*Use lubricant A.*
13. Install the new gasket.

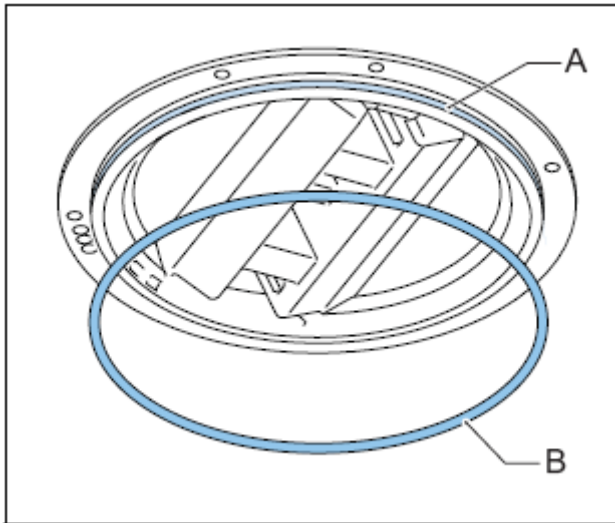

Connect to PCB

14. Connect the optical assy to input 1 and 2 on the PCB, if applicable.



**Note**

- INPUT 1 and INPUT 2 are labelled underneath the connector.
- When you have an unidirectional light, connect the optical assy to connector INPUT1

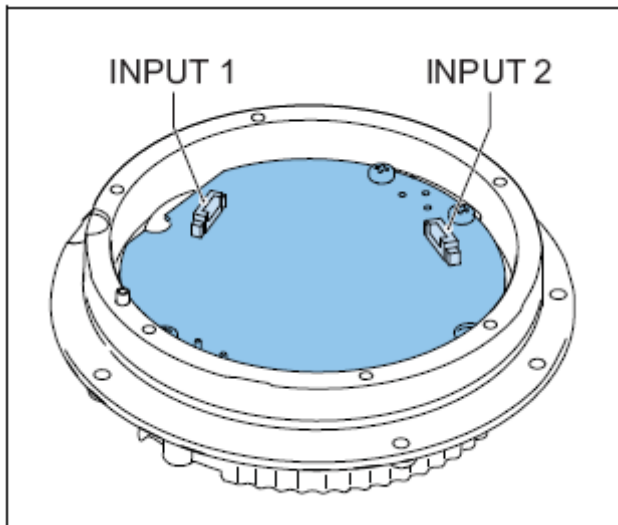

Assemble

15. Install the optical assy (A).



**Note**

Make sure that the locating pin (B) is set to the hole marked '0' of the optical assy

16. Install the new optical assy screws (D).

See [Screws](#) (torque).

17. Lubricate the new gasket of the pressure release screw.

Use Lubricant A.

18. Install a new gasket on the pressure release screw (E).
19. Install the pressure release screw.  
See [Screws](#) (torque).
20. Install the upper cover assy.  
See [Replace upper cover assy.](#)

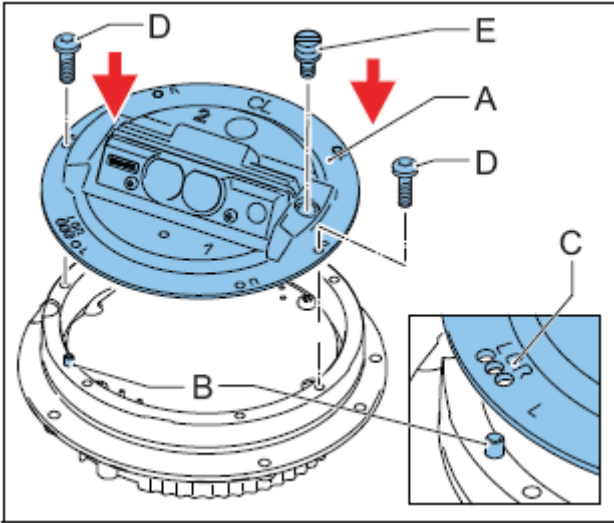

### 5.2.5 Replace inner cover assy

#### Parts

- Inner cover assy

#### Disassemble

1. Remove the optical assy.  
See § [Replace optical assy.](#)

#### Assemble

2. With a new inner cover assy, assemble the optical assy.  
See § [Replace optical assy.](#)

### 5.2.6 Replace cable lead

#### Parts

- Cable lead
- Cable lead screws.
- Plug bracket

#### Disassemble

1. Remove the cable lead screws (A).
2. Dispose of the cable lead screws.
3. Remove the plug bracket (C).
4. Remove the cable lead (B).



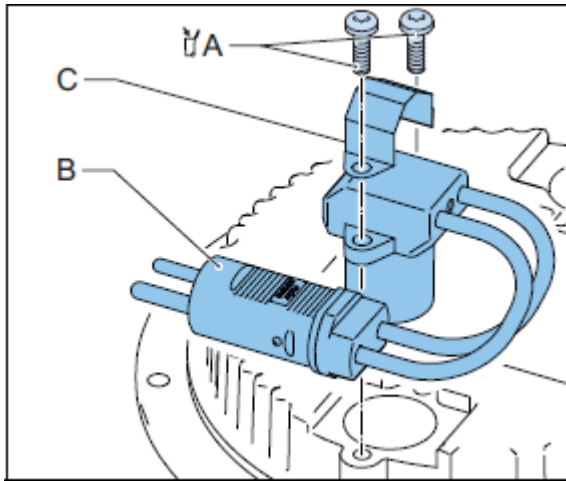

*Assemble*

5. Install the new cable lead.
6. Install the plug bracket.
7. Install the new cable lead screws.  
See [Screws](#) (torque).

### 5.2.7 Replace labyrinth gasket



**CAUTION**

Always dispose of the labyrinth gasket when you remove the fixture from the mounting support.



**Note**

Only valid for 8" version lights.

*Parts*

- Labyrinth gasket

*Disassemble*

1. Remove the labyrinth gasket (A).
2. Dispose of the labyrinth gasket.

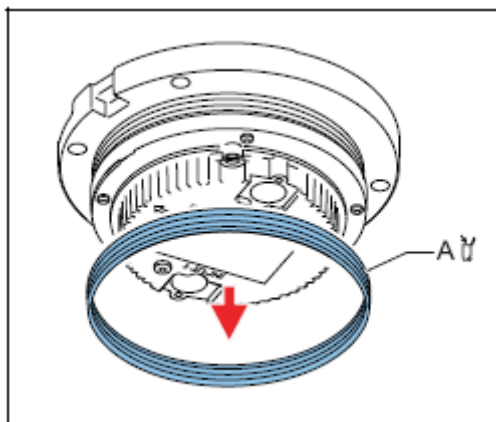

*Assemble*

3. Make sure that all parts are clean.

4. Pay special attention to the part where the labyrinth gasket must fit (A).
5. Install the new labyrinth gasket (B).

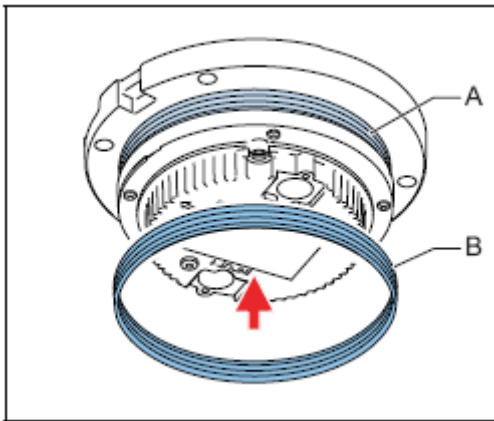

---

### 5.2.8 Repair a faulty light (monitoring option)

---



#### Note

The monitoring option is not available on APS fixtures.

---

#### Disassemble

1. Remove the upper cover assembly.  
See [Replace upper cover Assy.](#)
2. Remove the optical assembly.  
See [Replace optical Assy.](#)
3. Replace the fuse resistors.  
See [Replace the fuse resistor \(monitoring option\).](#)

#### Connect

4. Take a new optical Assy.
5. Connect the PCB.  
See [Replace optical Assy.](#)  
*Do not fasten the optical Assy.*
6. Do a fixture operation test.  
See [§ 5.4.](#)
7. If the fixture does not turn on:
  - a) Dispose of the used inner cover Assy.
  - b) Take a new inner cover Assy with new fuse resistors.
  - c) Connect the PCB.  
See [Replace optical Assy.](#)  
*Do not fasten the optical Assy.*
  - d) Do a fixture operation test.  
See [§ 5.4.](#)
  - e) If the fixture does not turn on, contact ADB.

#### Assemble

8. Assemble the optical assy.  
See [Replace optical assy.](#)
9. Assemble the upper cover assy.  
See [Replace upper cover assy.](#)
10. Dispose the used optical assembly.

### 5.2.9 Replace the fuse resistor (monitoring option)

**i Note**  
The monitoring option is not available on APS fixtures.

#### Parts

- Fuse resistor kit. See [DTS, DTC, DFC Spare Parts](#) .

#### Tools

- Pliers

**i Note**

- Bidirectional lights have two fuse resistors.
- Unidirectional lights have only one fuse resistor.
- Fuse resistors are located on the PCB of the inner cover assy
- Always replace all fuse resistors located on the PCB.

#### Disassemble

1. Remove the fuse resistor(s) (A) by pulling the legs of the fuse resistor.
2. Dispose of the old fuse resistor.
3. Take the new fuse resistor from the kit.
4. Place the new fuse resistor in the socket.

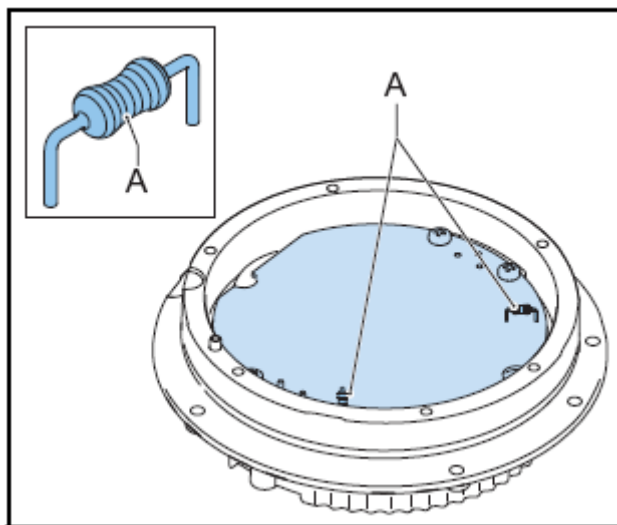

#### Assemble

5. Insert the legs of the new fuse resistor in the socket.

### 5.2.10 Testing for Leaks

To test for leaks, perform the following procedure:

1. See [Figure 6](#).

Remove pressure relief screw.

2. See [Figure 7](#).

Screw pressure test fitting into the pressure relief port (the opening created when the pressure relief screw is removed).  
Screw fitting hand-tight.

**Figure 6: Pressure Relief Screw**



**Figure 7: Pressure Test Fitting Assembly**

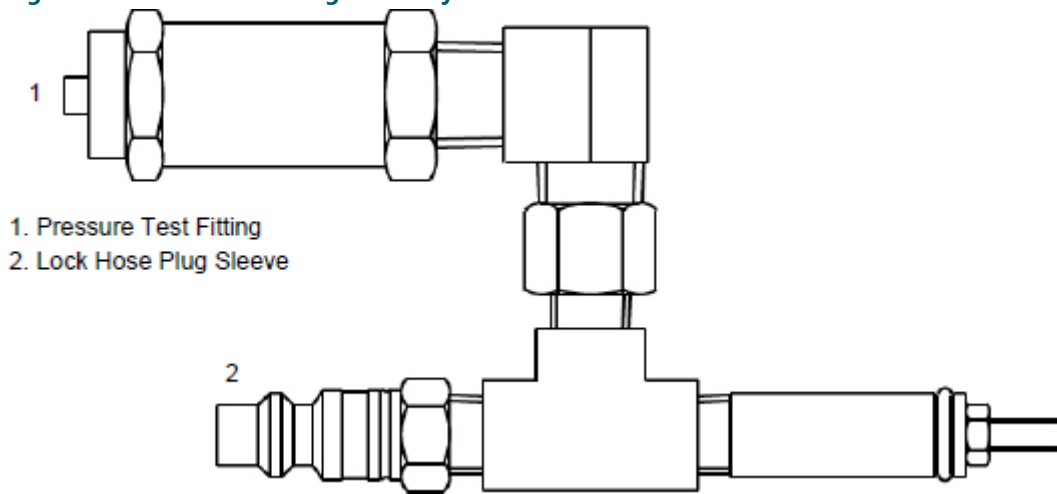

3. Attach the shop airline to the lock hose plug sleeve (2).
4. Pressurize to 20 psi.
5. Submerge the pressure test fitting in a water tank.  
Check for air bubbles. Air bubbles indicate a leak.
6. Locate the leak source, depressurize, replace the seal that is leaking, reassemble, and retest by following steps 4 and 5.  
If leak is fixed, depressurize and reinstall the pressure release screw (1).

Go to [Overview of Sequence of Work](#) to finish.

## 5.3 Material Handling Precautions: Fasteners



### DANGER

#### Foreign Object Damage - FOD

This equipment may contain fasteners that may come loose - torque properly.

- Only use fasteners of the same type as the one originally supplied with the equipment.
- Use of incorrect combination of gaskets, bolts and nuts can create severe damages to the product installation and create safety risk .
- You need to know what base the light fixture will be installed in, in order to chose the correct gasket, bolts and nuts.
- Bolt type, length, and torque value are determined by type of base, height of spacers used, and clamp force required in FAA Engineering Brief No 83 (latest revision).
- Due to the risk of bolts vibrating loose, do not use any type of washer with the fixing bolts (such as split lock washers) other than an anti-vibration washer. Anti-vibration washers as defined in FAA EB 83 (latest edition) must be used. For installations other than FAA, use the base can manufacturer's recommendations.
- Always tighten the fasteners to the recommended torque. Use a calibrated torque wrench and apply the recommended adhesive type.
- Obey the instructions of the adhesives necessary for the fasteners.

**Failure to follow these warnings may cause the fasteners to loosen, damage the equipment, potentially to loosen the equipment. This can lead to a highly dangerous situation of FOD, with potential lethal consequences.**



### Note

To minimize the risk of errors, the ADB SAFEGATE Sales Representative will have information on which gasket goes with which base. This information is also provided in the product Data sheets, the User Manuals and the Spare Part Lists.



### CAUTION

Use of incorrect combination of gaskets, bolts and nuts can create severe damages to the product installation and create multiple safety risks.

To obtain a safe and watertight installation the O-ring and retaining bolt stated in the document must be used.

You need to know what base the light fixture will be installed in, in order to choose the correct gasket, bolts and nuts.

**Failure to follow these cautions can result in equipment damage or aircraft FOD.**

## 5.4 Bolt Torque Preventive Maintenance Schedule

An established schedule for checking light fixture bolt torque and bolt condition is mandatory. This is particularly true for areas that are subject to high impact loads from aircraft such as runway status lights, runway touchdown zone lights, runway centerline lights, and taxiway lead-off lights. Although AC 150/5340-26 offers a recommended schedule for periodic checks, these checks should be tailored to the facility based on local conditions such as environmental issues and runway traffic load.

1. Torque according to: FAA Engineering Brief No 83 (latest revision).

**Figure 8: Anti-vibration washer example**

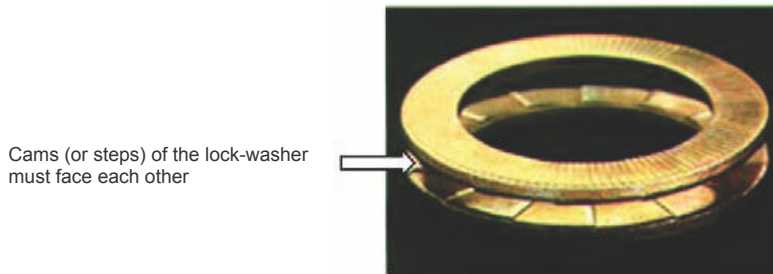

### CAUTION

Per FAA AC 150/5340-30, Chapter 10, and FAA Engineering Brief No 83 (latest revision), it is extremely important that other types of washers, such as split washers, must not be used. Failure to use properly installed anti-vibration lock washers will cause mounting bolts to become loose. The cams (or steps) of each half of the lock washer must face each other.

---

FAA Cert Alert No. 14-03 refers to AC 150/5340-26 for the frequency of checking bolt torque. AC 150/5340-26 (latest revision) paragraph 5.3.4.1.4, *Bi-Monthly Checks* states: "The torque of the bolts attaching the light fixture to its base should be checked with a calibrated torque wrench – never use an impact wrench."

Regular inspection as outlined in FAA Engineering Brief 83 (latest edition), Canada Civil Aviation Safety Alert Document CASA 2014-05, and any other applicable regulatory guidelines is critical in insuring torque on all bolts is restored to optimum values. Bolts that loosen more often should be inspected and re-torqued on a more frequent basis.

It is especially important to maintain a regular inspection schedule for LED fixtures. Since LED fixtures operate more reliably and are not subject to removal/replacement/re-torque as frequently as would be seen with incandescent fixtures, it is even more important to implement regular torque inspections.

It is critical that remedial action be taken if bolts are found to be loose or missing during inspection. If this occurs, it is important to carefully inspect all structural elements of the mounting system as defined in Installation. Also inspect the base can for general structural conditions such as:

- Is the base can solidly mounted in the pavement, and not moving or rocking during rollovers?
- If a base can extension is present, are all extension attachment bolts tight?

If poor base can structure or mounting system components are not in accordance with regulatory requirements or are in poor condition, it is the airport's responsibility to:

- Increase the frequency of bolt torque inspection to insure that no bolts become loose or missing.
- Quickly replace/repair the mounting system components, which may include replacing the entire base can.

Airport operators must also ensure these maintenance activities are properly documented.

### Digital Asset Tracking and Service Application Information

ALIS is ADB SAFEGATE's new digital asset tracking, inspection and service solution, helps airports easily register airside assets, electronically schedule and track maintenance, and record maintenance and inspection tasks in compliance with ICAO and FAA standards.

---

Easy to implement and use, cloud-based software enables a more reliable and fail-safe approach to asset tracking and maintenance by always using live field data and eliminating inefficiencies caused by human error. Every asset is registered using GPS data and its status recorded, so airport maintenance teams get a clearer view of maintenance schedules and history, allowing them to manage resources more effectively as well as improve the safety and longevity of airside assets. This increased visibility helps airports plan and schedule preventive maintenance, or undertake corrective maintenance more quickly, to reduce downtime and significantly improve operational availability.

<https://adbsafegate.com/product-center/airfield/airside-services/ALIS-airside-maintenance>

- Easily integrates electronic torque measurements and photometric measurement reports to provide a complete view of the asset's status.
- ALIS can be integrated with the AirTorque or Ingersoll Rand® QX series wrenches, which are used for accurate, ergonomic torque inspections of AGL fixtures. The applied torque can seamlessly be registered in the ALIS system as a part of the maintenance record.
- The iPhone application of ALIS – ALIS Personal – makes it easier than ever to register maintenance actions while working. It will proactively show you which assets you still need to work on and select the closest one to you automatically. ALIS Personal acts as a feedback and information device for the associated torque wrench.





## 6.0 Troubleshooting

### 6.1 Troubleshooting guide

**Table 2: Troubleshooting guide**

Problem	Possible cause	Possible solution
No light or light flickers	Connection to the input power has a malfunction.	- Remove the fixture. See § 4.4. - Check the electrical connection, the cable and the receptacles.
	The LED has a malfunction	Replace the optical assy. See <a href="#">Replace optical assy.</a>
	Connection of the optical assy to the PCB has a malfunction.	- Remove the optical assy. See <a href="#">Replace optical assy.</a> - Check the electrical connections and the cable.
	The PCB has a malfunction	Replace the inner cover assy. See <a href="#">Replace inner cover assy.</a>
Light output too low	The prism is dirty.	Clean the prism.
	The LED has a malfunction.	Replace the optical assy. See <a href="#">Replace optical assy.</a>
	The PCB has a malfunction.	Replace the inner cover assy. See <a href="#">Replace inner cover assy.</a>



## 7.0 Parts

### 7.1 Fixture code schema

Ordering Code	D	XX	XX	XX	XX	XX	A	XX	XX	XX	00	0
<b>AD=light</b>	•											
<b>Application</b>												
TS = Taxiway or stop bar straight section												
TC = Taxiway or stop bar curved section	•											
FS = Enhanced taxiway light for rapid exit <sup>1</sup>												
<b>Cord Set Style and length</b>												
A = Standard version (Style 6 plugs), 10" long <sup>2</sup>												
G = German Style 1 (2-pin), 10" long <sup>2</sup>												
F = French Style 1 (3-pin), 10" long <sup>2</sup>												
L = Style 6 (2-pin), 18" long (FAA) <sup>3</sup>												
<b>Cable and Connector</b>												
2 = 1 plug (2-pin)												
3 = 2 plugs (2-pin)												
4 = 1 plug (3-pin)												
5 = 2 plugs (3-pin)												
<b>LED Color 1 – Left</b>												
R = Red												
G = Green												
Y = Yellow <sup>3</sup>												
N = Obscure / Blank (No light)												
<b>LED Color 2 – Right</b>												
R = Red												
G = Green												
Y = Yellow <sup>3</sup>												
N = Obscure / Blank (No light)												
<b>Toe-in</b>												
0 = No toe-in for DTS/DFS												
3 = Both Sides for DTC												
<b>Dimensions</b>												
A = 8" diameter, 1/2" (12.7mm) protrusion												
<b>Power Supply and Monitoring</b>												
S = 6.6A - 50/60Hz series supply, w/out monitoring												
M = 6.6A - 50/60Hz series supply, with monitoring												
A = APS system												
<b>Standards</b>												
0 = ICAO, TP 312 and FAA												
I = ICAO and TP 312 only <sup>3</sup>												
K = Australian (color complaint to MCS 139)												
<b>Winter Options</b>												
0 = None												
2 = Heavy-duty abrasion-resistant lens coating <sup>4</sup>												
<b>Fixed Digit</b>												
00												
<b>Version</b>												
1 = 2 LEDs per window												

#### Ordering Code Notes

- <sup>1</sup> Conditions for DFS lights for rapid exit taxiways:
  - Color cannot be red
  - No toe-in
  - No APS power supply
  - Standard must be ICAO
- <sup>2</sup> 8" fixtures with 10" cord sets are for installation on shallow bases.
- <sup>3</sup> Fixtures with 18" cord sets are for installation on deep base cans.
- <sup>4</sup> Typically used for intensive winter service where sand is applied to runways and rotating brushes are used

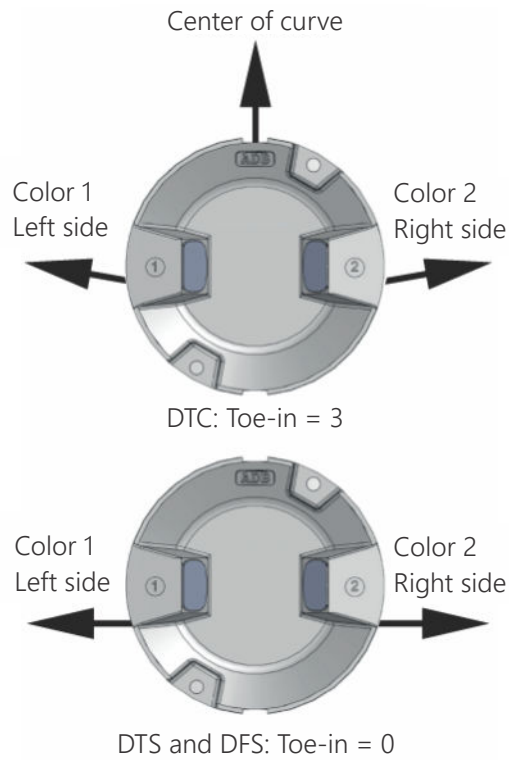

## 7.2 Hardware kits



### Note

HPI bases only accept metric fasteners.

### Metric fasteners kits

To install 8" inset lights on ADB 8" mounting supports.

Hardware kit		Components					
Description	ADB Part number	7100.08.759 Stainless steel screw M10 X25	7150.53.320 Stainless steel nut M10	7156.53.330 Stainless steel self locking nut M10	7284.10.470 Stainless steel lock washer M10	7284.70.345 Nylon encapsulated washer M10	4071.50.240 Metric anti- rotation pin
Metric screw kit 8" (with anti- rotation pins)	1411.20.400	2			2		2
Metric nut kit 8"	1411.20.420		2		2		
Self-locking metric nut kit 8"	1411.20.430			2			
Metric screw kit 8" (Germany)	1411.20.441	2				2	
Metric screw kit 8" (without anti-rotation pins)	1411.20.522	2			2		

### UNC fasteners kit

To install 8" inset lights on ADB 8" mounting supports.

Hardware kit		Components		
Description	ADB Part number	7200.13.806 Stainless steel screw 3/8" - 16 UNC	7284.10.470 Stainless steel lock washer M10	4071.50.120 UNC anti-rotation pin
UNC screw kit 8"	1411.20.411	2	2	2

## 7.3 Exploded view and components

### 7.3.1 Exploded view

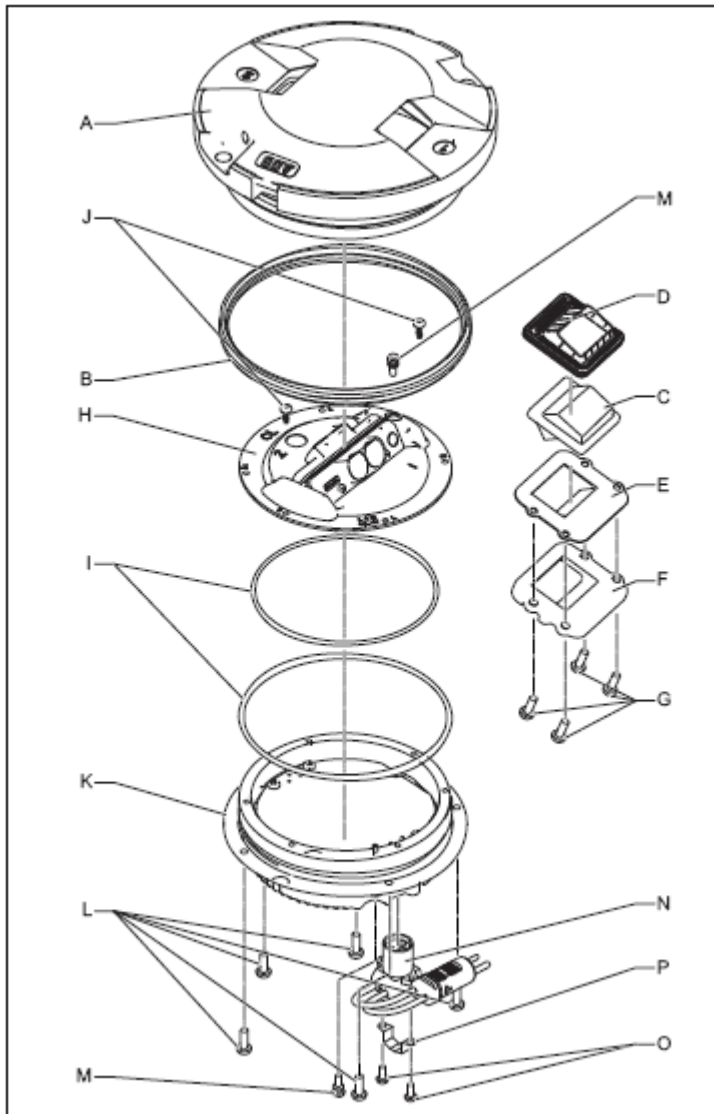

### 7.3.2 DTS, DTC, DFC Spare Parts

	<b>Components</b>	<b>Versions</b>	<b>DFS</b>	<b>DTS</b>	<b>DTC</b>
A	Upper cover assy (includes metal cover, prisms, prism gaskets, prism protection plates, prism screws and prism brackets)	Unidirectional, window 1	4072.50.920	4072.50.920	4072.50.950
		Unidirectional, window 2	4072.50.910	4072.50.910	4072.50.940
		Bidirectional	4072.50.900	4072.50.900	4072.50.930
B	Labyrinth gasket (10 pcs)		4072.76.560	4072.76.560	4072.76.560
	Labyrinth gasket (100 pcs)		4072.76.570	4072.76.570	4072.76.570
C	Prism	Straight sections	SP4072.18.336	SP4072.18.336	-
		Curved sections, left (window 1)	-	-	4072.24.701
		Curved sections, right (window 2)	-	-	4072.24.691
D	Prism gasket (10 pcs)		SP4072.18.363	SP4072.18.363	SP4072.18.363
E	Prism protection plate (10 pcs)		SP4072.18.380	SP4072.18.380	SP4072.18.380
F	Prism bracket (10 pcs)		SP4072.18.350	SP4072.18.350	SP4072.18.350
H	Optical assy, for 6.6A - 50/60Hz series supply (with our without monitoring)	Red / Red	-	4072.52.270	4072.52.420
		Red / Green	-	4072.52.290	-
		Red / Blank	-	4072.52.250	4072.52.400
		Green / Red	-	4072.52.300	-
		Green / Green	4072.62.000	4072.52.280	4072.52.430
		Green / Yellow	4072.62.010	4072.52.370	4072.52.520
		Green / Blank	4072.62.020	4072.52.310	4072.52.460
		Yellow / Green	4072.62.040	4072.52.360	4072.52.510
		Yellow / Yellow	4072.62.030	4072.52.330	4072.52.480
		Yellow / Blank	4072.62.050	4072.52.340	4072.52.490
		Blank / Red	-	4072.52.260	4072.52.410
		Blank / Green	4072.62.060	4072.52.320	4072.52.470
		Blank / Yellow	4072.62.070	4072.52.350	4072.52.500

	<b>Components</b>	<b>Versions</b>		<b>DFS</b>	<b>DTS</b>	<b>DTC</b>
H	Optical assy, for APS power supply	Red / Red		-	4072.63.020	4072.63.520
		Red / Green		-	4072.63.040	-
		Red / Blank		-	4072.63.000	4072.63.500
		Green / Red		-	4072.63.050	-
		Green / Green		-	4072.63.030	4072.63.530
		Green / Yellow		-	4072.63.120	4072.63.620
		Green / Blank		-	4072.63.060	4072.63.560
		Yellow / Green		-	4072.63.110	4072.63.610
		Yellow / Yellow		-	4072.63.080	4072.63.580
		Yellow / Blank		-	4072.63.090	4072.63.590
		Blank / Red		-	4072.63.010	4072.63.510
		Blank / Green		-	4072.63.070	4072.63.570
		Blank / Yellow		-	4072.63.100	4072.63.600
I	O-ring gasket (100 pcs)	For optical assy		SP.7080.90.295	SP.7080.90.295	SP.7080.90.295
		For inner cover		SP.7080.90.310	SP.7080.90.310	SP.7080.90.310
K	Inner cover assy for 6.6A, 50/60Hz series supply without monitoring	1 input	For unidirectional light	4072.24.960	4072.24.960	4072.24.960
			For bidirectional light	4072.25.100	4072.24.960	4072.24.960
		2 inputs	For bidirectional light	4072.25.200	4072.25.200	4072.25.200
K	Inner cover assy for 6.6A, 50/60Hz series supply with monitoring	1 input	For unidirectional light	4072.25.120	4072.25.120	4072.25.120
			For bidirectional light	4072.25.230	4072.25.120	4072.25.120
		2 inputs	For bidirectional light	4072.25.240	4072.25.240	4072.25.240

## Parts

	Components	Versions		DFS	DTS	DTC
K	Inner cover assy for APS power supply	1 input	For green unidirectional light	-	4072.61.740	4072.61.740
			For yellow and for red unidirectional light	-	4072.61.730	4072.61.730
			For green/ green bidirectional light	-	4072.61.700	4072.61.700
			For yellow/ green and for red/ green bidirectional light	-	4072.61.710	4072.61.710
			For green/ yellow and for green/red bidirectional light	-	4072.61.720	4072.61.720
			For yellow/ yellow and for red/ red bidirectional light	-	4072.61.810	4072.61.810
		2 Inputs	For green/ green bidirectional light	-	4072.61.750	4072.61.750
			For yellow/green and for red/green bidirectional light	-	4072.61.760	4072.61.760
			For green/ yellow and for green/red bidirectional light	-	4072.61.770	4072.61.770
			For yellow/yellow and for red/red bidirectional light	-	4072.61.820	4072.61.820
N	Cable lead (10 pcs)	With Style 6 2-pole plug		SP4072.24.951	SP4072.24.951	SP4072.24.951
		With Style 1 2-pole plug (German version)		SP4072.24.731	SP4072.24.731	SP4072.24.731
		With flat 3-pole plug (French version)		SP4072.40.370	SP4072.40.370	SP4072.40.370
		18" long, with Style 6 2-pole plug		SP4072.42.350	SP4072.42.350	SP4072.42.350
	Fuse resistor kit (20 resistors)	Monitoring option		6132.00.250	6132.00.250	6132.00.250
P	Plug bracket (10 pcs)			SP4072.42.380	SP4072.42.380	SP4072.42.380
	Modification sticker (10 pcs)			SP4072.27.810	SP4072.27.810	SP4072.27.810

## 7.3.3 Screws

Screw type	Name	Details	Spare Part Number	Torque (Nm)	Adhesive type <sup>1</sup>
G	Prism screws (100 pcs)	SCREW M5x14 DIN 7985-T- A2-LOCK 2045	SP.7100.10.211	4.0	Not required
J	Optical assy screws (40 pcs)	SCREW M4x10 DIN 7985-T- A2-LOCK 2045	SP.7100.10.101	2.5	Not required
L	Inner cover screws (100 pcs)	SCREW M5x14 DIN 7985-T- A2-LOCK 2045	SP.7100.10.211	3.5	Not required



Screw type	Name	Details	Spare Part Number	Torque (Nm)	Adhesive type <sup>1</sup>
M	Pressure release screw assy (10 pcs)	(screw + gasket)	SP.4072.24.940	2.5	Not required
	Pressure release gasket (10 pcs)	Gasket only	SP.7080.90.012		
O	Cable lead screws (40 pcs)	SCREW M4x10 DIN 7985-T- A2-LOCK 2045	SP.7100.10.101	2.5	Not required
	Fasteners of the mounting support (refer to interoperability matrix appendix)				

#### Notes

<sup>1</sup> 1) See [Standard toolkit](#).

## 7.4 Standard toolkit

	Details	Article number
	Complete tool kit. <i>The toolist consists of the components listed below.</i>	1411.19.421
	Tool case	6169.01.007
Adhesive A <sup>1</sup>	Loctite 2701	7870.05.130
Adhesive B <sup>1</sup>	Loctite 222	7870.05.140
Adhesive C <sup>1</sup>	Loctite 638	7870.05.097
Adhesive D <sup>1</sup>	Loctite 243	7870.05.160
Lubricant A	Vacuum silicone grease (50 g) to install O-ring gaskets	7850.42.220
Lubricant B	Molykote HP870 Inerta (100 g) to replace prism	7850.05.061
Tool A	Torque wrench	8061.06.255
Tool B	Socket, hex 3/8", screw 3/8", J9/16LA	8961.06.008
Tool C	Socket, hex 3/8", screw M10, J 17LA	8961.06.000
Tool D	Socket, 1/4", 1.6x8 Flat, RS.8E	8961.05.050
Tool E	Socket, 1/4", Pozidriv2, RD.2	8961.05.060
Tool F	Extension, 1/4", R.210	8961.06.220
Tool G	Adaptation, 1/4"-3/8", R.232	8961.06.010
Tool H	Hinged handle - sort	8961.06.110
Tool I	Pliers	8981.10.110
Tool J	Opening tool	4071.53.220
Tool K	Screwdriver, flat blade AG. 8x150	8961.06.250
Tool L	Screwdriver, pozidriv AD.2x125	8961.05.220
Tool M	Torque screwdriver	8961.06.255
Tool N	Screwdriver, Torx ANX20x100	8961.05.300

	<b>Details</b>	<b>Article number</b>
Tool O	Screwdriver, Torx ANX25x100	8961.05.290
Tool P	Attack driver	8961.04.100
Tool Q	Hammer 212A50s	8961.04.110
Tool R	Bit holder	8961.04.120
Tool S	Bits END202, Pozidriv2	8961.04.130
Tool T	Bit, Torx TX20 EX.620	8961.06.020
Tool U	Bit, Torx TX25 EX.625	8961.06.025

**Notes**

<sup>1</sup> 1) Obey the instructions of the manufacturer of the adhesive.

## 7.5 Additional accessories

You can buy these accessories separately.

<b>Tool</b>	<b>Details</b>	<b>Article number</b>
A	Waterproof test adapter inset 8" AD-light	1411.17.150
B	Set of spare anchor hooks for lifting tool 1411.19.550	1411.19.560
C	Lifting tool (on wheels)	1420.55.600
D	Basic lifting tool assembly for inset lights	1411.19.550

## Appendix A: INTEROPERABILITY

### ADB SAFEGATE Interoperability



#### CAUTION

Use of incorrect combination of gaskets, bolts and nuts can create severe damages to the product installation and create multiple safety risks.

To obtain a safe and watertight installation the O-ring and retaining bolt stated in the document must be used.

You need to know what base the light fixture will be installed in, in order to choose the correct gasket, bolts and nuts.

**Failure to follow these cautions can result in equipment damage or aircraft FOD.**

**Table 3: Interoperability matrix**

Base type	Required O-ring	Bolt installation		Stud installation	
		Required dimension	Recommended torque	Required nut	Recommended torque
ADB 8" Eurobase;	White labyrinth gasket	1411.20.522	21 Nm + Loctite 2701	1411.20.430	21 Nm + Loctite 2701
ADB 8" HPI;	4072.24.781 / 1 pc	Metric screw kit 25		Self-locking nut kit	
Adapter ring ADB 8" to 12"	4072.76.560 / 10 pcs 4072.76.570 / 100 pcs	mm		H100	



#### Note

Contact your ADB SAFEGATE Sales representative for more information.



## Appendix B: CABLE LOSS

The cable resistance R (ohms) for 1 conductor is calculated with following formula:

- $R \text{ (ohms)} = \text{resistivity of material (ohm m)} \times \text{length (m)} / \text{cross sectional area (m}^2\text{)}$
- For copper conductors the resistivity is  $1.72 \times 10^{-8} \text{ (m}^2\text{)}$

Example; for 1 km  $2.5 \text{ mm}^2$  copper conductor, the resistance R is calculated as follows:

$$1.72 \times 10^{-8} \times 1000 / 2.5 \times 10^{-6} \text{ m}^2 = 6.88 \text{ ohms}$$

The loss (Watt) is then  $R \times I^2$  or  $6.88 \text{ ohms} \times 6.6^2 \text{ A}^2 = 299.69 \text{ W/km}$  or  $0.299 \text{ W/m}$ .

The loss (Watt) for a secondary cable with 2 conductors is thus  $2 \times 0.299 = 0.599$  or  $0.6 \text{ W/m}$ .

As such we can calculate:

- Secondary cable for a  $2.5 \text{ mm}^2$  Cu-wire (2 conductors):  $0.6 \text{ W/m}$
- Secondary cable for a  $4 \text{ mm}^2$  Cu-wire (2 conductors):  $0.4 \text{ W/m}$
- Primary cable for a  $6 \text{ mm}^2$  Cu-wire (1 conductor):  $0.12 \text{ W/m}$

The cable between the isolation transformer and the lamp adds losses that cannot be ignored when dimensioning the circuits and selecting rating for secondary transformers and regulators.



### WARNING

Cable lengths should not exceed 100 meters.

For a secondary cable of e.g., 20 m of  $2.5 \text{ mm}^2$  CU-wire,  $20 \text{ m} \times 0.6 \text{ W/m} = 12 \text{ W}$  equals the additional loss to be taken into account.

For a primary cable of e.g., 100 m of  $6 \text{ mm}^2$  CU-wire,  $100 \text{ m} \times 0.12 \text{ W/m} = 12 \text{ W}$  equals the additional loss to be taken into account.



## Appendix C: SUPPORT

Our experienced engineers are available for support and service at all times, 24 hour/7 days a week. They are part of a dynamic organization making sure the entire ADB SAFEGATE is committed to minimal disturbance for airport operations.

### ADB SAFEGATE Support

#### Live Technical Support - Americas

If at any time you have a question or concern about your product, just contact ADB SAFEGATE's technical service department. Trained in all areas of system issues, troubleshooting, quality control and technical assistance, our highly experienced Technical support specialists are available 24 hours a day, seven days a week to provide assistance over the phone.

ADB SAFEGATE **Americas Technical Service & Support (US & Canada): +1-800-545-4157**

**ADB SAFEGATE Americas Technical Service & Support (International): +1-614-861-1304**

During regular business hours, you can also Chat with a Service Technician. We look forward to working with you!

#### Before You Call

When you have an airfield lighting or system control system problem it is our goal to support airfield maintenance staff as quickly as possible. To support this effort we ask that you have the following information ready before calling.

- The *airport code*
- If not with an airport, then company name (prefer customer id number)
- Contact phone number and email address
- Product with part number preferable or product number
- Have you reviewed the product's manual and troubleshooting guide
- Do you have a *True RMS* meter available (and any other necessary tools)
- Be located with the product ready to troubleshoot

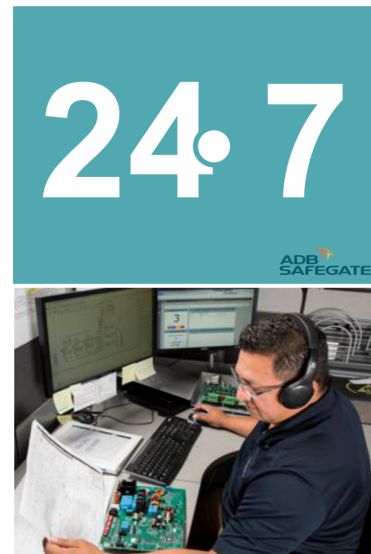

#### Note

For more information, see [www.adbsafegate.com](http://www.adbsafegate.com), or contact ADB SAFEGATE Support via email at [support@adbsafegate.com](mailto:support@adbsafegate.com) or

Brussels: +32 2 722 17 11

Rest of Europe: +46 (0) 40 699 17 40

Americas: +1 614 861 1304. Press 3 for technical service or press 4 for sales support.

China: +86 (10) 8476 0106

### C.1 ADB SAFEGATE Website

The ADB SAFEGATE website, [www.adbsafegate.com](http://www.adbsafegate.com), offers information regarding our airport solutions, products, company, news, links, downloads, references, contacts and more.

## C.2 Recycling

### C.2.1 Local Authority Recycling

The disposal of ADB SAFEGATE products is to be made at an applicable collection point for the recycling of electrical and electronic equipment. The correct disposal of equipment prevents any potential negative consequences for the environment and human health, which could otherwise be caused by inappropriate waste handling. The recycling of materials helps to conserve natural resources. For more detailed information about recycling of products, contact your local authority city office.

### C.2.2 ADB SAFEGATE Recycling

ADB SAFEGATE is fully committed to environmentally-conscious manufacturing with strict monitoring of our own processes as well as supplier components and sub-contractor operations. ADB SAFEGATE offers a recycling program for our products to all customers worldwide, whether or not the products were sold within the EU.

ADB SAFEGATE products and/or specific electrical and electronic component parts which are fully removed/separated from any customer equipment and returned will be accepted for our recycling program.

All items returned must be clearly labeled as follows:

- For *ROHS/WEEE* Recycling
- Sender contact information (Name, Business Address, Phone number).
- Main Unit Serial Number.

ADB SAFEGATE will continue to monitor and update according for any future requirements for *EU directives* as and when *EU member states* implement new *regulations* and or *amendments*. It is our aim to maintain our *compliance plan* and assist our customers.



## Company Addresses

<p>ADB SAFEGATE</p>	<p>ADB SAFEGATE, Belgium: Leuvensesteenweg 585, B-1930 Zaventem Belgium</p>
<p>Contact: Tel.: +32 2 722 17 11, Fax: +32 2 722 17 64</p>	<p>Email: <a href="mailto:marketing@adbsafegate.com">marketing@adbsafegate.com</a> Internet: <a href="http://www.adbsafegate.com">www.adbsafegate.com</a></p>
<p>Americas LLC</p>	<p>ADB SAFEGATE, Americas: 977 Gahanna Parkway, Columbus, OH 43230 USA</p>
<p>Contact: Tel.: +1 (614) 861 1304, Fax: +1 (614) 864 2069</p>	<p>Email: <a href="mailto:sales.us@adbsafegate.com">sales.us@adbsafegate.com</a> Internet: <a href="http://www.adbsafegate.com">www.adbsafegate.com</a></p>
<p>ADB SAFEGATE Sweden AB</p>	<p>ADB SAFEGATE, Sweden: Djurhagegatan 19 SE-213 76 Malmö Sweden</p>
<p>Contact: Tel.: +46 (0)40 699 17 00, Fax: +46 (0)40 699 17 30</p>	<p>Email: <a href="mailto:marketing@adbsafegate.com">marketing@adbsafegate.com</a> Internet: <a href="http://www.adbsafegate.com">www.adbsafegate.com</a></p>
<p>ADB SAFEGATE Airfield Technologies Ltd. China</p>	<p>ADB SAFEGATE, China: Unit 603, D Block, CAMIC International Convention Center, No 3, Hua Jia Di East road, ChaoYang district, Beijing 100102 P.R. China</p>
<p>Contact: Tel.: +86 (10) 8476 0106, Fax: +86 (10) 8476 0090</p>	<p>Email: <a href="mailto:china@safegate.com">china@safegate.com</a> Internet: <a href="http://www.adbsafegate.com">www.adbsafegate.com</a></p>
<p>ADB SAFEGATE Germany GmbH</p>	<p>ADB SAFEGATE Germany GmbH, Mannheim: Konrad-Zuse-Ring 6, D-68163 Mannheim Germany</p>
<p>Contact: Tel.: +49 (621) 87 55 76-0, Fax: +49 (621) 87 55 76-55</p>	<p>Email: <a href="mailto:marketing@adbsafegate.com">marketing@adbsafegate.com</a> Internet: <a href="http://www.adbsafegate.com">www.adbsafegate.com</a></p>



## Powering Your Airport Performance from Approach to Departure

[adbsafegate.com](https://adbsafegate.com)

Copyright © ADB SAFEGATE, all rights reserved

