

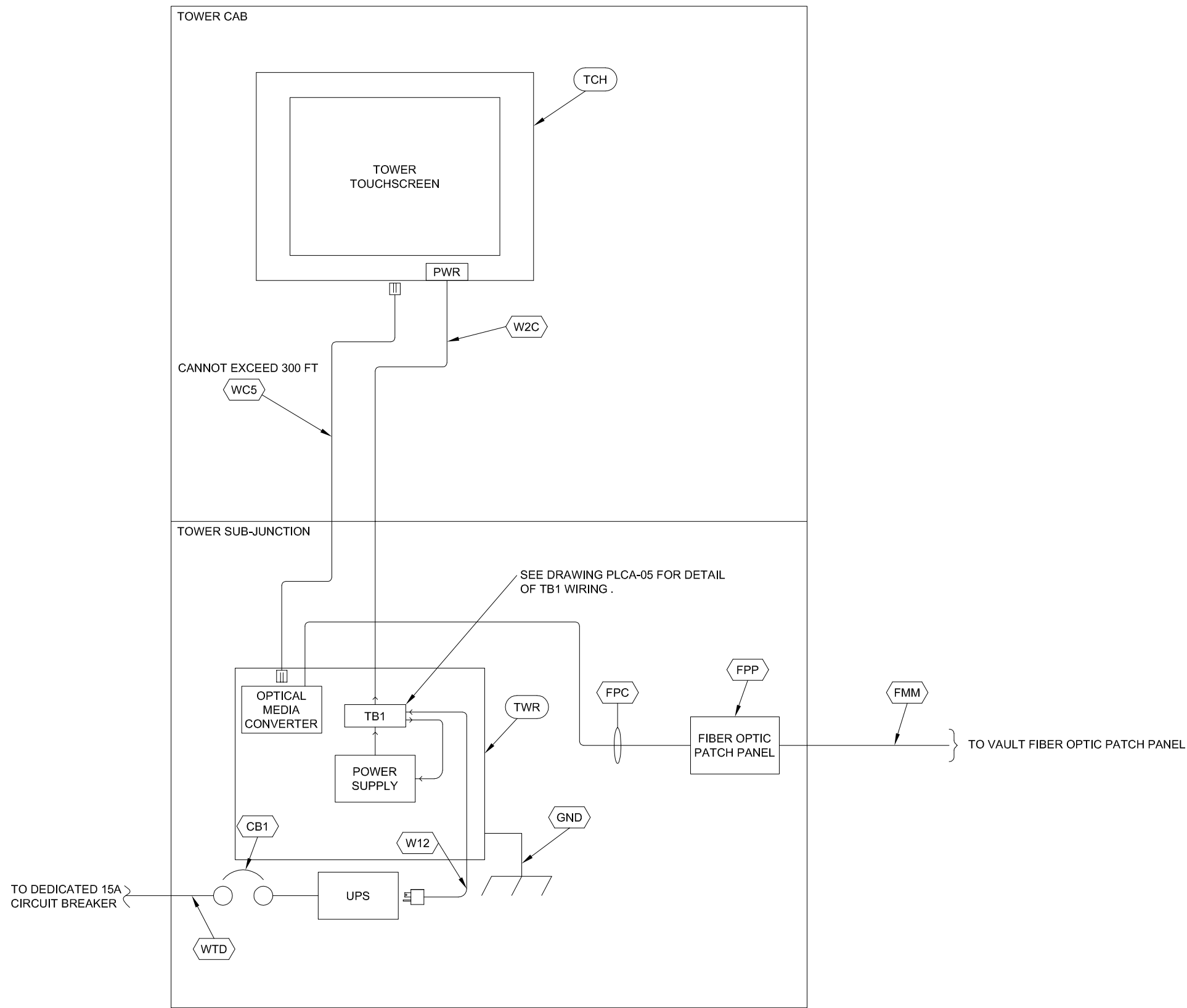

Sample L-890 ALCMS Drawings

PLC Architecture



ITEMS SUPPLIED BY ADB AIRFIELD SOLUTIONS			
PHASE 1 GENERAL ASSEMBLY BILL OF MATERIALS			
ITEM NO.	PART NUMBER	PART NAME/ DESCRIPTION	QTY
VLT	VAULT	VAULT PLC ENCLOSURE	1
TWR	TOWER	TOWER PLC ENCLOSURE	1
TCH	TOUCHSCREEN	TOUCHSCREEN ASSEMBLY	1
CSR	CSR	CURRENT SENSING RELAYS, 24VDC	15

ITEMS SUPPLIED BY ELECTRICAL CONTRACTOR		
GENERAL ASSEMBLY BILL OF MATERIALS		
ITEM NO.	PART NAME/ DESCRIPTION	QTY
CB1	CIRCUIT BREAKER, 15A	A/R
FPC	FIBER PATCH CABLE, SINGLE-MODE 8.3 MICRON	A/R
FPP	FIBER PATCH PANEL, SURFACE MOUNT	A/R
FMM	FIBER, COMM. LINK, SINGLE-MODE, 8.3 MICRON	A/R
GND	WIRE, 12AWG, STRANDED	A/R
W2C	WIRE, 2 CONDUCTOR 12AWG STRANDED	A/R
W5C	WIRE, 24AWG, SOLID BARE COPPER, CAT 5, NON-PLENUM, UNSHEILD (BLENDEN# 1583A OR EQUIVALENT) (CONTACT PLC MANUFACTURER)	A/R
WTD	WIRE TO DEDICATED 15A, 120VAC CIRCUIT	A/R
W12	WIRE, 3 CONDUCTOR, 12AWG, STRANDED, UPS POWER	A/R
W18	WIRE, 18AWG, 600V, CONDUCTORS AS REQUIRED	A/R

- INSTALLATION NOTES:**
- = SUPPLIED BY CONTRACTOR
  - = SUPPLIED BY PLC AIRFIELD LIGHTING CONTROL SYSTEM MANUFACTURER

DRAWING TITLE: PLC AIRFIELD LIGHTING CONTROL SYSTEM SYSTEM OVERVIEW - BLOCK DIAGRAM  
 DRAWING NUMBER: PLCA-01  
 REV: B  
 ADB Airfield Solutions  
 977 Galathea Parkway, Columbus, Ohio 43230  
 Telephone: 614-861-1304, Fax: 614-864-2069  
 Copyright © 2014 ADB Airfield Solutions.

**CAUTION:**  
 THIS DRAWING IS ONLY INTENDED FOR USE AS GENERAL AIRFIELD SYSTEM DESIGN GUIDANCE. THE DESIGNER MUST VERIFY DESIGN WITH LOCAL CODES AND VARYING CHARACTERISTICS FOR EACH UNIQUE AIRFIELD APPLICATION.

**INSTALLATION NOTES:**

1. CURRENT SENSING RELAYS SHALL BE INSTALLED INSIDE CCR'S BY CONTRACTOR.
2. ONE CABLE IS REQUIRED FOR MONITORING EACH CURRENT SENSING RELAY.
3. ONE CABLE IS REQUIRED FOR EACH REGULATOR CONTROL.
4. CONTRACTOR IS RESPONSIBLE FOR LOCATING AND CONNECTING DRY CONTACT MONITORING POINTS.

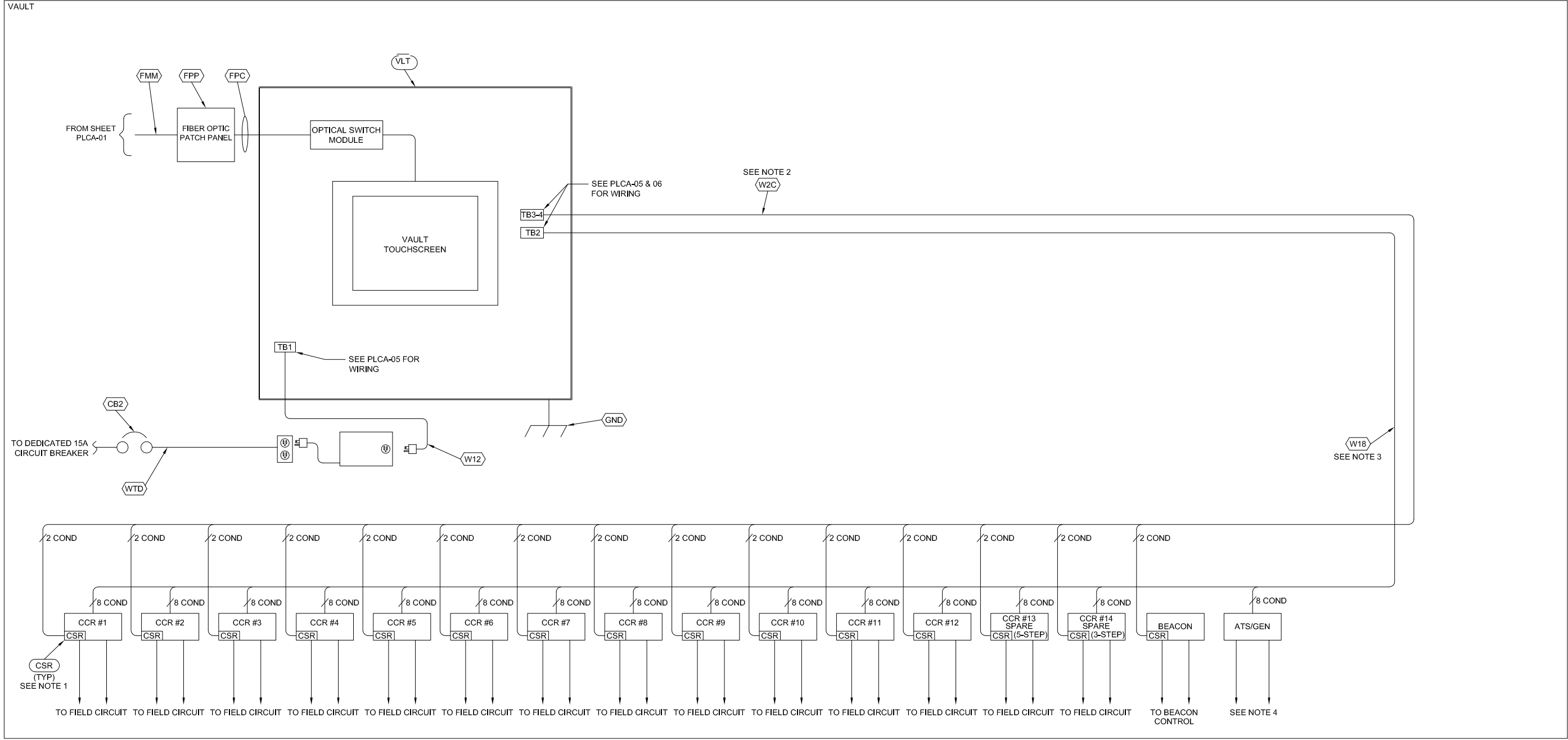

**CAUTION:**

THIS DRAWING IS ONLY INTENDED FOR USE AS GENERAL AIRFIELD SYSTEM DESIGN GUIDANCE. THE DESIGNER MUST VERIFY DESIGN WITH LOCAL CODES AND VARYING CHARACTERISTICS FOR EACH UNIQUE AIRFIELD APPLICATION.

ASSOCIATED DRAWINGS:

DRAWN BY:

DATE:

INITIALS:

DATE:

REVISION DESCRIPTION

REV. LEVEL

DATE

BY

DATE

DESCRIPTION

LEVEL

DATE

BY

DATE

DESCRIPTION

LEVEL

DATE

BY

DATE

DESCRIPTION

LEVEL

DATE

BY

DATE

DESCRIPTION

LEVEL

DATE

BY

DATE

DESCRIPTION

LEVEL

DATE

BY

DATE

DESCRIPTION

LEVEL

DATE

BY

DATE

DESCRIPTION

LEVEL

DATE

BY

DATE

DESCRIPTION

LEVEL

DATE

BY

DATE

DESCRIPTION

LEVEL

DATE

BY

DATE

DESCRIPTION

LEVEL

DATE

BY

DATE

DESCRIPTION

LEVEL

DATE

BY

DATE

DESCRIPTION

LEVEL

DATE

BY

DATE

DESCRIPTION

LEVEL

DATE

BY

DATE

DESCRIPTION

LEVEL

DATE

BY

DATE

DESCRIPTION

LEVEL

DATE

BY

DATE

DESCRIPTION

LEVEL

DATE

BY

DATE

DESCRIPTION

LEVEL

DATE

BY

DATE

DESCRIPTION

LEVEL

DATE

BY

DATE

DESCRIPTION

LEVEL

DATE

BY

DATE

DESCRIPTION

LEVEL

DATE

BY

DATE

DESCRIPTION

LEVEL

DATE

BY

DATE

DESCRIPTION

LEVEL

DATE

BY

DATE

DESCRIPTION

LEVEL

DATE

BY

DATE

DESCRIPTION

LEVEL

DATE

BY

DATE

DESCRIPTION

LEVEL

DATE

BY

DATE

DESCRIPTION

LEVEL

DATE

BY

DATE

DESCRIPTION

LEVEL

DATE

BY

DATE

DESCRIPTION

LEVEL

DATE

BY

DATE

DESCRIPTION

LEVEL

DATE

BY

DATE

DESCRIPTION

LEVEL

DATE

BY

DATE

DESCRIPTION

LEVEL

DATE

BY

DATE

DESCRIPTION

LEVEL

DATE

BY

DATE

DESCRIPTION

LEVEL

DATE

BY

DATE

DESCRIPTION

LEVEL

DATE

BY

DATE

DESCRIPTION

LEVEL

DATE

BY

DATE

DESCRIPTION

LEVEL

DATE

BY

DATE

DESCRIPTION

LEVEL

DATE

BY

DATE

DESCRIPTION

LEVEL

DATE

BY

DATE

DESCRIPTION

LEVEL

DATE

BY

DATE

DESCRIPTION

LEVEL

DATE

BY

DATE

DESCRIPTION

LEVEL

DATE

BY

DATE

DESCRIPTION

LEVEL

DATE

BY

DATE

DESCRIPTION

LEVEL

DATE

BY

DATE

DESCRIPTION

LEVEL

DATE

BY

DATE

DESCRIPTION

LEVEL

DATE

BY

DATE

DESCRIPTION

LEVEL

DATE

BY

DATE

DESCRIPTION

LEVEL

DATE

BY

DATE

DESCRIPTION

LEVEL

DATE

BY

DATE

DESCRIPTION

LEVEL

DATE

BY

DATE

DESCRIPTION

LEVEL

DATE

BY

DATE

DESCRIPTION

LEVEL

DATE

BY

DATE

DESCRIPTION

LEVEL

DATE

BY

DATE

DESCRIPTION

LEVEL

DATE

BY

DATE

DESCRIPTION

LEVEL

DATE

BY

DATE

DESCRIPTION

LEVEL

DATE

BY

DATE

DESCRIPTION

LEVEL

DATE

BY

DATE

DESCRIPTION

LEVEL

DATE

BY

DATE

DESCRIPTION

LEVEL

DATE

BY

DATE

DESCRIPTION

LEVEL

DATE

BY

DATE

**NOTES:**

1. CONTRACTOR TO WIRE ALL CCR'S USING THE SAME COLOR CODE SCHEME AS SHOWN
2. CONTRACTOR TO INSTALL CURRENT SENSING RELAYS (CSR) PROVIDED BY PLC AIRFIELD LIGHTING CONTROL SYSTEM MANUFACTURER INTO EACH CCR, AND WIRE ONE CCR OUTPUT CABLE THROUGH CSR. CONTRACTOR TO VERIFY CSR TRIM POT IS ADJUSTED SUCH THAT THE CSR CLOSES WHEN THERE IS > 2.5A ON THE OUTPUT. ADJUST POTENTIOMETER TO "TRIP" WHEN CCR IS TURNED ON TO STEP 1. FAST BLINKING LIGHT = ON.

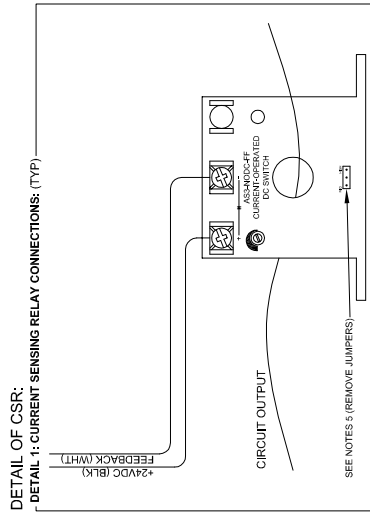

3. CONTRACTOR IS RESPONSIBLE FOR LOCATING, TERMINATING AND TESTING ALL GENERATOR / ATS MONITORED POINTS. CONTRACTOR SHALL CONTACT EQUIPMENT MANUFACTURER OR AIRPORT ENGINEER AS REQUIRED.
4. CONTRACTOR TO DETERMINE IF VOLTAGE SOURCE IS AC OR DC.
5. REMOVE ALL JUMPERS BEFORE INSTALLATION.

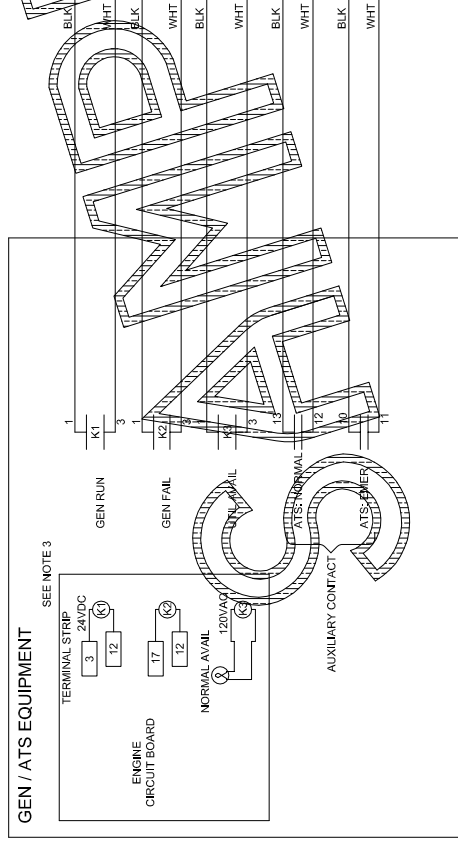
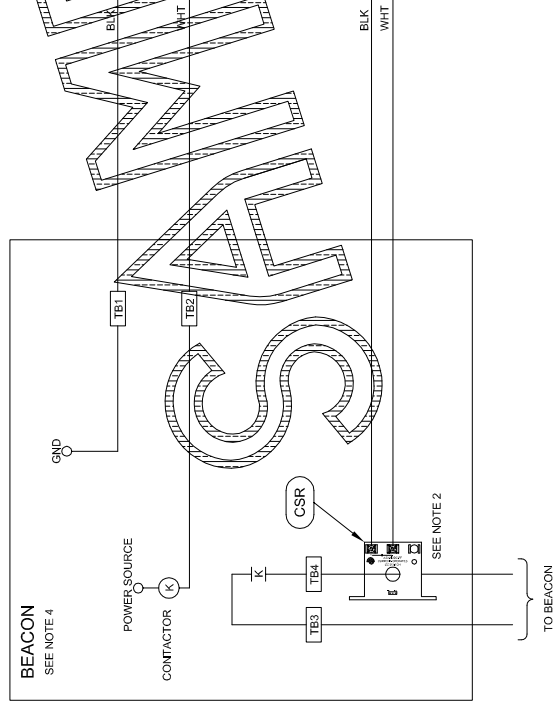
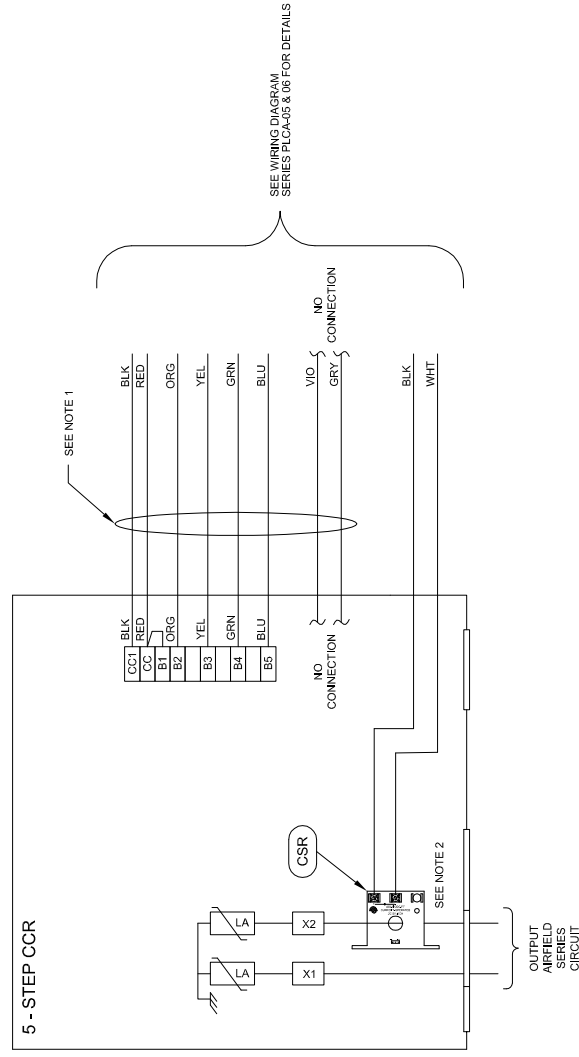
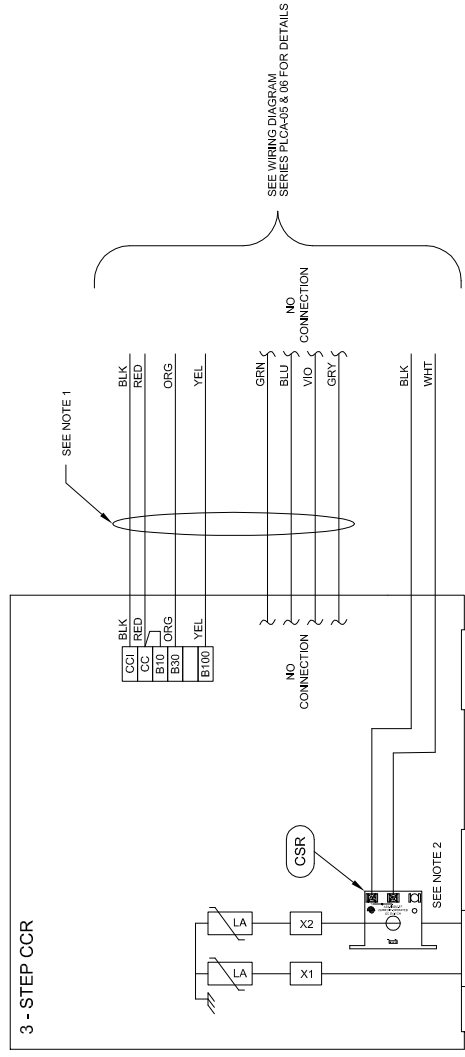

**CAUTION:**

THIS DRAWING IS ONLY INTENDED FOR USE AS GENERAL AIRFIELD SYSTEM DESIGN GUIDANCE. THE DESIGNER MUST VERIFY DESIGN WITH LOCAL CODES AND VARYING CHARACTERISTICS FOR EACH UNIQUE AIRFIELD APPLICATION.

DRAWING TITLE: PLC AIRFIELD LIGHTING CONTROL SYSTEM SYSTEM EXTERNALS - 3 & 5 STEP CCR TYPICAL WIRING DIAGRAM		REV. LEVEL	REVISION DESCRIPTION	DRAWN BY	REV. DATE	REV. LEVEL	REVISION DESCRIPTION	DRAWN BY	REV. DATE	ASSOCIATED DRAWINGS:	CONTROLLED COPY
		B								Unauthorised duplication of this document in whole or part is prohibited. Initialled in RED ink below indicates authorized copy.	
DRAWING NUMBER: <b>PLCA-03</b>										INITIAL & DATE:	
										All information contained herein, including illustrations, drawings, and schedules, is as of the date of this publication, but is subject to change without notice. ADB reserves the right to make changes and improvements to its products and assumes no responsibility for these modifications. ADB Airfield Solutions may otherwise agree to in writing. Copyright © 2014 ADB Airfield Solutions.	
										ADBE Airfield Solutions 977 Gahanna Parkway, Columbus, Ohio 43230 Telephone: 614-861-1304, Fax: 614-864-2069	

CONTROLLED COPY  
Unauthorized duplication of this document in whole or part is prohibited.  
Initiated in RED ink below indicates authorized copy.

ASSOCIATED DRAWINGS:  
DRAWN BY:  
DRAWN DATE:

REV. DATE

DRAWN BY

REVISION DESCRIPTION

REV. LEVEL

DRAWING NUMBER:  
**PLCA-04**

INITIAL DATE:  
**ADBE**  
Airfield Solutions  
977 Galanna Parkway, Columbus, Ohio 43230  
Telephone: 614-861-1304, Fax: 614-864-2069

All information contained herein, including illustrations, drawings, and schedules, is the property of ADBE and is subject to change without notice. ADBE reserves the right to make changes and improvements to its products and services without notice. The user agrees to indemnify and hold ADBE Airfield Solutions harmless from any claims or damages arising out of the use of the products and services provided hereunder. Copyright © 2014 ADBE Airfield Solutions.

**CONSTANT CURRENT REGULATOR INDEX**

CCR OUTPUT					CCR INFORMATION					CCR MONITORING			CIRCUIT SEL	
Name	PLC	Function	Rating (6.6A/20A)	Size (kW)	Steps (1/3/5)	Control Power (120/48 I/E)	FAA Type (L-828/L-829)	Man.	Man. Model #	Lamps Out	IRMS	Current Sensing (ON/OFF)	CS#	Loop #
CCR 1	VLT	Runway 18-36 Edge A	6.6	30	5	120 - I	L-828	C-H		-	-	X	-	-
CCR 2	VLT	Runway 18-36 Edge B	6.6	30	5	120 - I	L-828	C-H		-	-	X	-	-
CCR 3	VLT	Runway 9-27 Edge	6.6	15	3	120 - I	L-828	ADB		-	-	X	-	-
CCR 4	VLT	9-27 PAPI	6.6	10	3	120 - I	L-828	ADB		-	-	X	-	-
CCR 5	VLT	Runway 13-31 Edge	6.6	15	3	120 - I	L-828	ADB		-	-	X	-	-
CCR 6	VLT	Runway Guard Lights	6.6	4	3	120 - I	L-828	Maniarco		-	-	X	-	-
CCR 7	VLT	Taxiway G Edge	6.6	20	3	120 - I	L-828	ADB		-	-	X	-	-
CCR 8	VLT	Taxiway C West Edge	6.6	15	3	120 - I	L-828	C-H		-	-	X	-	-
CCR 9	VLT	Taxiway B South Edge	6.6	20	3	120 - I	L-828	C-H		-	-	X	-	-
CCR 10	VLT	Taxiway B North Edge	6.6	15	3	120 - I	L-828	ADB		-	-	X	-	-
CCR 11	VLT	Taxiway A South Edge	6.6	20	3	120 - I	L-828	C-H		-	-	X	-	-
CCR 12	VLT	Taxiway A North Edge	6.6	30	3	120 - I	L-828	Hevi-Duty		-	-	X	-	-
CCR 13	VLT	Spare 1 (5 Step)	6.6	30	5	120 - I	L-828	SAS		-	-	X	-	-
CCR 14	VLT	Spare 2 (3 Step)	6.6	30	3	120 - I	L-828	SAS		-	-	X	-	-
Beacon	VLT	Beacon	-	-	1			Contactor		-	-	X	-	-

**MONITORING INDEX**

Monitored Point	PLC Location	Function	Monitoring Requirement	Rating	PLC Input	Normal State	Alarm State	Event State	Manufacturer	Man. Model #	COMMENTS
GEN RUN	VLT	Monitors Generator Running Signal	Dry Contact Closure	1A	24VDC Sinking	OPEN	-	CLOSED			Contractor responsible for location, termination and testing of feedback
GEN FAIL	VLT	Monitors Generator Failure Signal	Dry Contact Closure	1A	24VDC Sinking	OPEN	CLOSED	CLOSED			Contractor responsible for location, termination and testing of feedback
UTIL AVAIL	VLT	Monitors when Utility is available	Dry Contact Closure	1A	24VDC Sinking	CLOSED	OPEN	OPEN			Contractor responsible for location, termination and testing of feedback
ATS: NORMAL	VLT	Monitors when ATS switch is in Normal Position	Dry Contact Closure	1A	24VDC Sinking	CLOSED	-	OPEN			Contractor responsible for location, termination and testing of feedback point
ATS: EMER	VLT	Monitors when ATS switch is in Emergency Position	Dry Contact Closure	1A	24VDC Sinking	OPEN	-	CLOSED			Contractor responsible for location, termination and testing of feedback point

**CAUTION:**

**THIS DRAWING IS ONLY INTENDED FOR USE AS GENERAL AIRFIELD SYSTEM DESIGN GUIDANCE. THE DESIGNER MUST VERIFY DESIGN WITH LOCAL CODES AND VARYING CHARACTERISTICS FOR EACH UNIQUE AIRFIELD APPLICATION.**

DRAWING TITLE:  
PLC AIRFIELD LIGHTING CONTROL SYSTEM  
CCR / MISCELLANEOUS CONTROL  
& MONITORING INDEX

**TB1**

PC / PLC ENCLOSURE  
TERMINAL STRIP 1

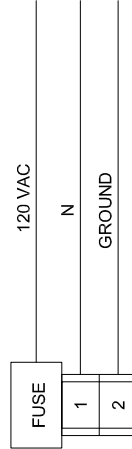

120 VAC  
PULLED FROM UPS

**TB2**

PC / PLC ENCLOSURE  
TERMINAL STRIP 2

CONNECTIONS TO  
REGULATORS

1	CURRENT FEEDBACK DETECTED	WHT	CCR 1
2	CURRENT FEEDBACK DETECTED	WHT	CCR 2
3	CURRENT FEEDBACK DETECTED	WHT	CCR 3
4	CURRENT FEEDBACK DETECTED	WHT	CCR 4
5	CURRENT FEEDBACK DETECTED	WHT	CCR 5
6	CURRENT FEEDBACK DETECTED	WHT	CCR 6
7	CURRENT FEEDBACK DETECTED	WHT	CCR 7
8	CURRENT FEEDBACK DETECTED	WHT	CCR 8
9	CURRENT FEEDBACK DETECTED	WHT	CCR 9
10	CURRENT FEEDBACK DETECTED	WHT	CCR 10
11	CURRENT FEEDBACK DETECTED	WHT	CCR 11
12	CURRENT FEEDBACK DETECTED	WHT	CCR 12
13	CURRENT FEEDBACK DETECTED	WHT	CCR 13
14	CURRENT FEEDBACK DETECTED	WHT	CCR 14
15	CURRENT FEEDBACK DETECTED	WHT	FUTURE 1
16	CURRENT FEEDBACK DETECTED	WHT	FUTURE 2
17	BEACON FEEDBACK	WHT	BEACON
18	CURRENT FEEDBACK DETECTED	WHT	FUTURE 3
19	CURRENT FEEDBACK DETECTED	WHT	FUTURE 4
20	CURRENT FEEDBACK DETECTED	WHT	FUTURE 5
21	GENERATOR RUNNING FEEDBACK	WHT	GENERATOR RUNNING FEEDBACK
22	GENERATOR FAILURE FEEDBACK	WHT	GENERATOR FAILURE FEEDBACK
23	UTILITY AVAILABLE FEEDBACK	WHT	UTILITY AVAILABLE FEEDBACK
24	ATS: NORMAL POSITION FEEDBACK	WHT	ATS: NORMAL POSITION FEEDBACK
25	ATS: IN EMERGENCY POSITION FEEDBACK	WHT	ATS: EMERGENCY POSITION FEEDBACK
26			
27			
28			
29			
30			

SPARE  
TERMINAL BLOCKS

**TB3**

PC / PLC ENCLOSURE  
TERMINAL STRIP 3

1	CCR 1	(120 VAC SOURCE)	BLK
2	CCR 2	(120 VAC SOURCE)	BLK
3	CCR 3	(120 VAC SOURCE)	BLK
4	CCR 4	(120 VAC SOURCE)	BLK
5	CCR 5	(120 VAC SOURCE)	BLK
6	CCR 6	(120 VAC SOURCE)	BLK
7	CCR 7	(120 VAC SOURCE)	BLK
8	CCR 8	(120 VAC SOURCE)	BLK
9	CCR 9	(120 VAC SOURCE)	BLK
10	CCR 10	(120 VAC SOURCE)	BLK
11	CCR 11	(120 VAC SOURCE)	BLK
12	CCR 12	(120 VAC SOURCE)	BLK
13	CCR 13	(120 VAC SOURCE)	BLK
14	CCR 14	(120 VAC SOURCE)	BLK
15	FUTURE 1	(120 VAC SOURCE)	BLK
16	FUTURE 2	(120 VAC SOURCE)	BLK
17	BEACON	(120 VAC SOURCE)	BLK
18	FUTURE 3	(120 VAC SOURCE)	BLK
19	FUTURE 4	(120 VAC SOURCE)	BLK
20	FUTURE 5		BLK
21	GENERATOR RUNNING FEEDBACK		BLK
22	GENERATOR FAILURE FEEDBACK		BLK
23	UTILITY AVAILABLE FEEDBACK		BLK
24	ATS: NORMAL POSITION FEEDBACK		BLK
25	ATS: EMERGENCY POSITION FEEDBACK		BLK
26			
27			
28			
29			
30			

SPARE  
TERMINAL BLOCKS

**CAUTION:**

THIS DRAWING IS ONLY INTENDED FOR USE AS GENERAL AIRFIELD SYSTEM DESIGN GUIDANCE. THE DESIGNER MUST VERIFY DESIGN WITH LOCAL CODES AND VARYING CHARACTERISTICS FOR EACH UNIQUE AIRFIELD APPLICATION.

DRAWING TITLE:  
PLC AIRFIELD LIGHTING CONTROL SYSTEM  
TERMINAL STRIP - CONTRACTOR CONNECTIONS

DRAWING NUMBER:  
**PLCA-05**

REV. **B**

ASSOCIATED DRAWINGS:  
PLCA-11

DRAWN BY:

DATE:

REVISION LEVEL

REV. DATE

DRAWN BY

REVISION DESCRIPTION

**CONTROLLED COPY**  
Unauthorized duplication of this document in whole or part is prohibited.  
Initiated in RED ink below indicates authorized copy.

INITIALS DATE:

**ADBE**  
Airfield Solutions

977 Galathea Parkway, Columbus, Ohio 43230  
Telephone: 614-861-1304, Fax: 614-864-2069

All information contained herein, including illustrations, drawings, and schedules, is the property of ADBE and is provided as is of the date of this publication, but is subject to change without notice. ADBE reserves the right to make changes and improvements to its products and assumes no responsibility for these modifications. ADBE Airfield Solutions may otherwise agree to in writing. Copyright © 2014 ADBE Airfield Solutions.



GENERAL BILL OF MATERIAL			
Item #	Description	U/M	QTY
TCH	MP 370 TCHSCRN, 12" TFT LCD, 256 COLORS	EA	1
CPM	COMPACT MEMORY CARD, 32 MB	EA	1

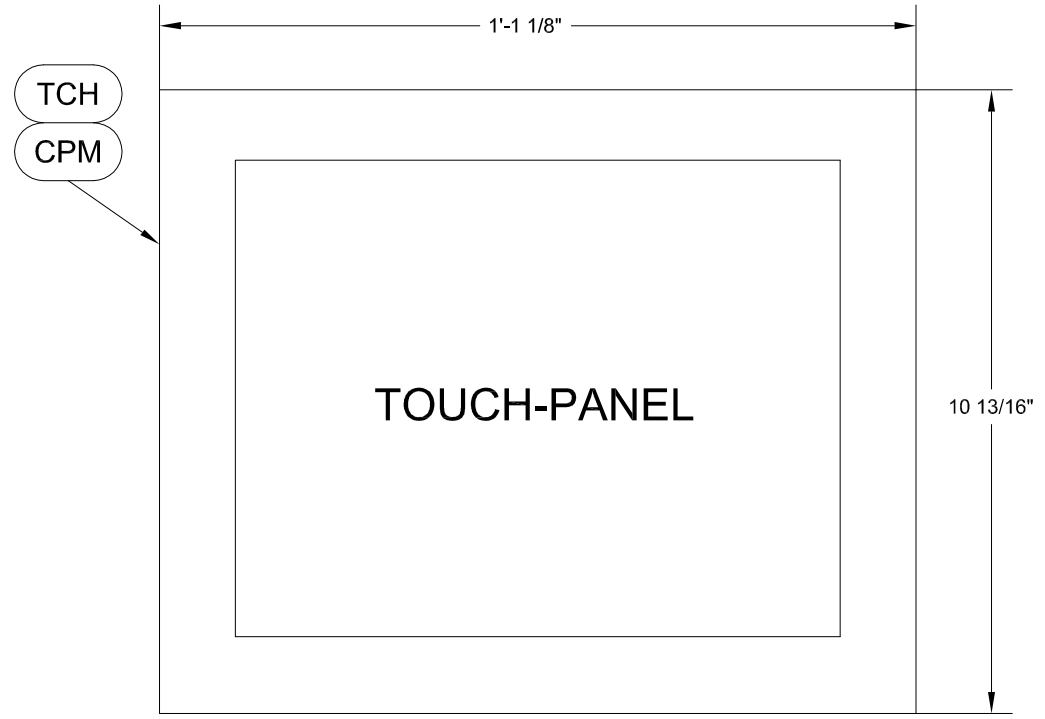

TOP VIEW

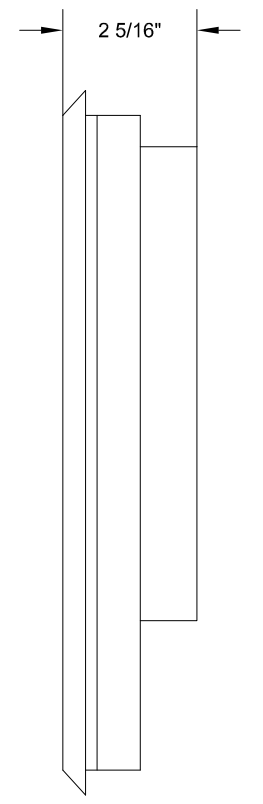

SIDE VIEW

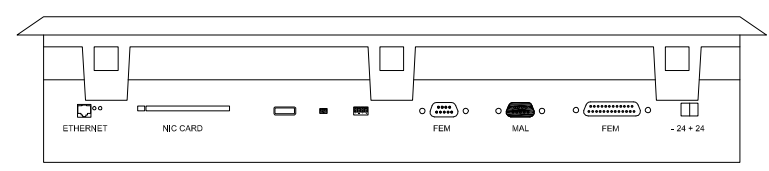
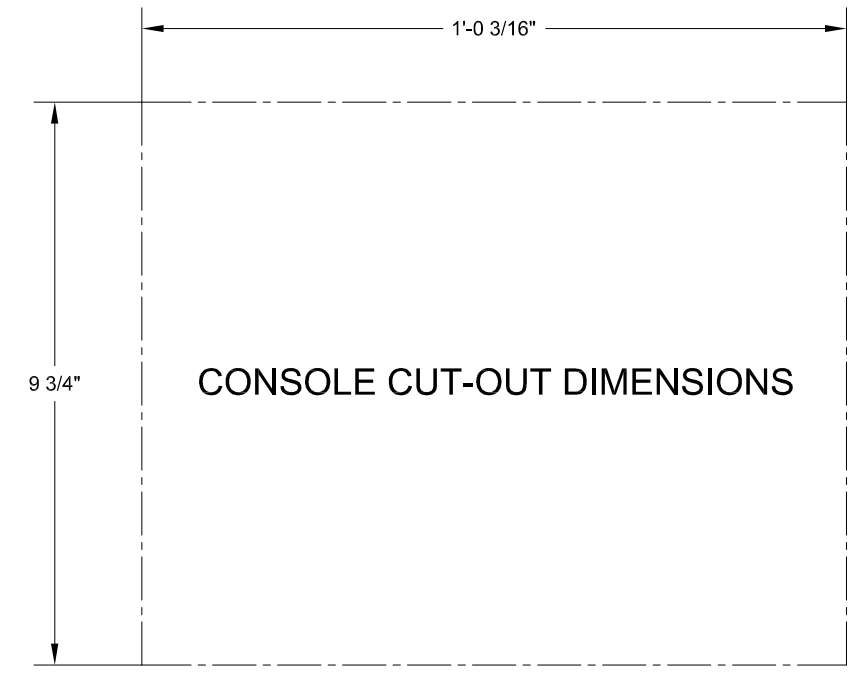

FRONT VIEW

**CAUTION:**  
 THIS DRAWING IS ONLY INTENDED FOR USE AS GENERAL AIRFIELD SYSTEM DESIGN GUIDANCE. THE DESIGNER MUST VERIFY DESIGN WITH LOCAL CODES AND VARYING CHARACTERISTICS FOR EACH UNIQUE AIRFIELD APPLICATION.

DRAWING TITLE: PLC AIRFIELD LIGHTING CONTROL SYSTEM  
 12" TOUCHSCREEN ASSEMBLY

DRAWING NUMBER: **PLCA-07**

REV. **B**

REV. LEVEL	REVISION DESCRIPTION	DRAWN BY	REV. DATE

ASSOCIATED DRAWINGS:

DRAWN BY:

DRAWN DATE:

INITIAL DATE:

**CONTROLLED COPY**  
 Unauthorized duplication of this document in whole or part is prohibited.  
 Initialed in RED ink below indicates authorized copy.

**ADBE**  
 Airfield Solutions  
 977 Galathea Parkway, Columbus, Ohio 43230  
 Telephone: 614-861-1304, Fax: 614-864-2069

All information contained herein, including illustrations, drawings, and specifications, is the property of ADB and is to be used as of the date of this publication, but is subject to change without notice. ADB reserves the right to make changes and improvements to its products and assumes no responsibility for these modifications. ADB Airfield Solutions may otherwise agree to in writing. Copyright © 2014 ADB Airfield Solutions.



GENERAL BILL OF MATERIAL			
Item #	Description	U/M	QTY
TCH	MP 370 TCHSCRN, 15.1 TFT LCD, 256 COLORS	EA	1
CPM	COMPACT MEMORY CARD, 32 MB	EA	1

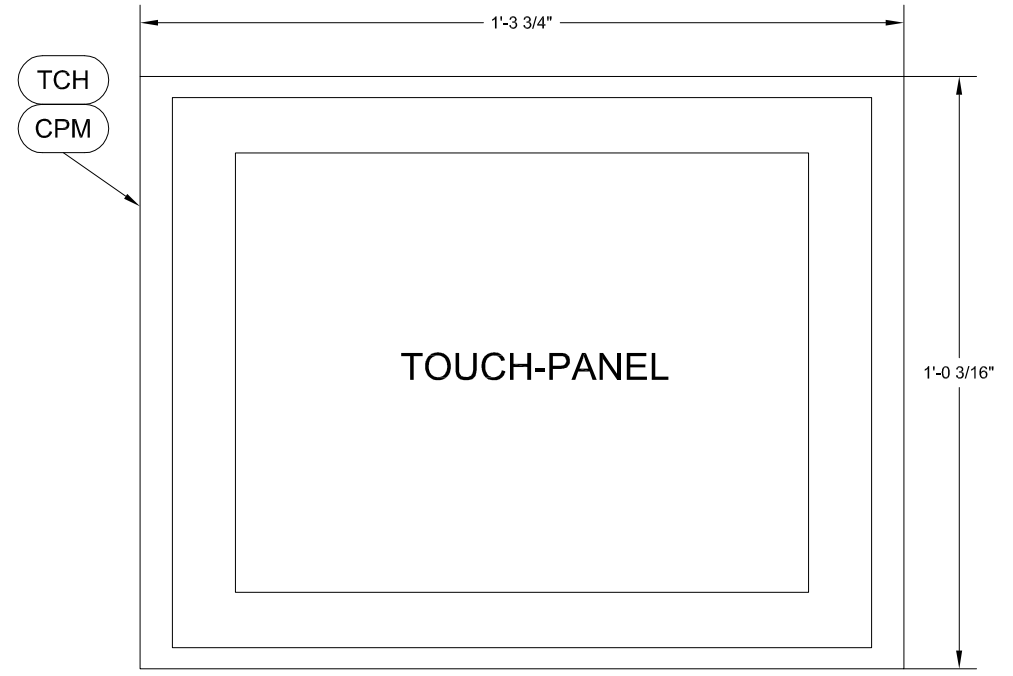

TOP VIEW

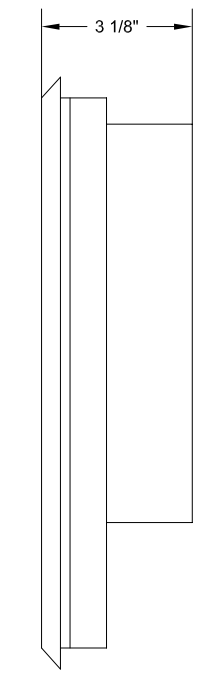

SIDE VIEW

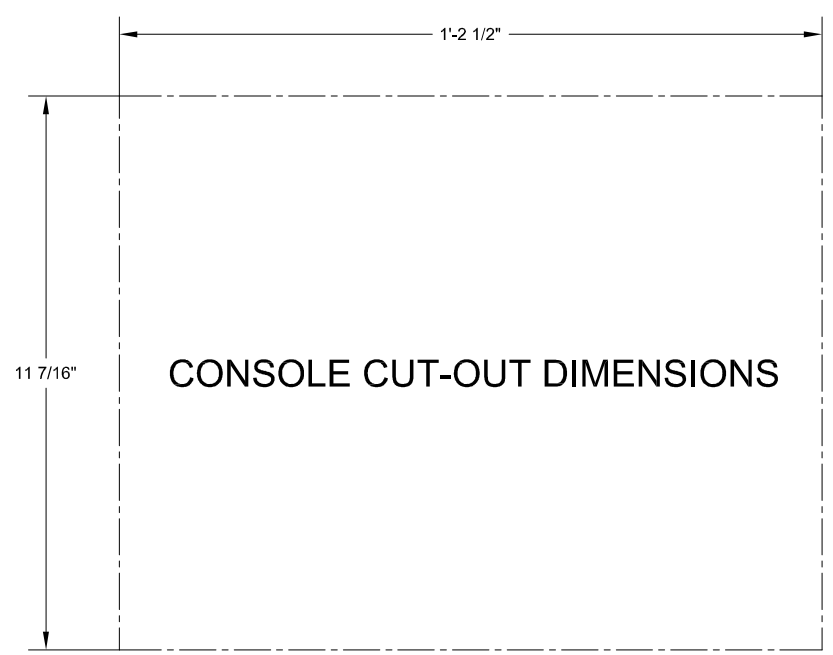

CONSOLE CUT-OUT DIMENSIONS

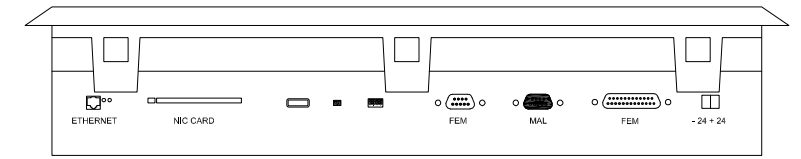

FRONT VIEW

**NOTES:**

- 15K RESISTOR 1/4W, TO BE SOLDERED WITH 2 LAYERS OF HEAT SHRINK TUBING TO SPEAKER + (OVER RESISTOR).
- THERE ARE ONLY 1-MALE & 1-FEMALE CONNECTOR SHOWN ON THIS DRAWING. FOR PLACEMENT OF REMAINING 2 CONNECTORS SEE DRAWING 43A3001.

**CAUTION:**

THIS DRAWING IS ONLY INTENDED FOR USE AS GENERAL AIRFIELD SYSTEM DESIGN GUIDANCE. THE DESIGNER MUST VERIFY DESIGN WITH LOCAL CODES AND VARYING CHARACTERISTICS FOR EACH UNIQUE AIRFIELD APPLICATION.

DRAWING TITLE: PLC AIRFIELD LIGHTING CONTROL SYSTEM 15" TOUCHSCREEN ASSEMBLY	REV. <b>B</b>	ASSOCIATED DRAWINGS: DRAWN BY: DRAWN DATE:	CONTROLLED COPY Unauthorized duplication of this document in whole or part is prohibited. Initialed in RED ink below indicates authorized copy.
	DRAWING NUMBER: <b>PLCA-08</b>	REVISION DESCRIPTION REV. LEVEL DRAWN BY REV. DATE	INITIAL & DATE: <b>ADBE</b> <b>Airfield Solutions</b> 977 Galathea Parkway, Columbus, Ohio 43230 Telephone: 614-861-1304, Fax: 614-864-2069

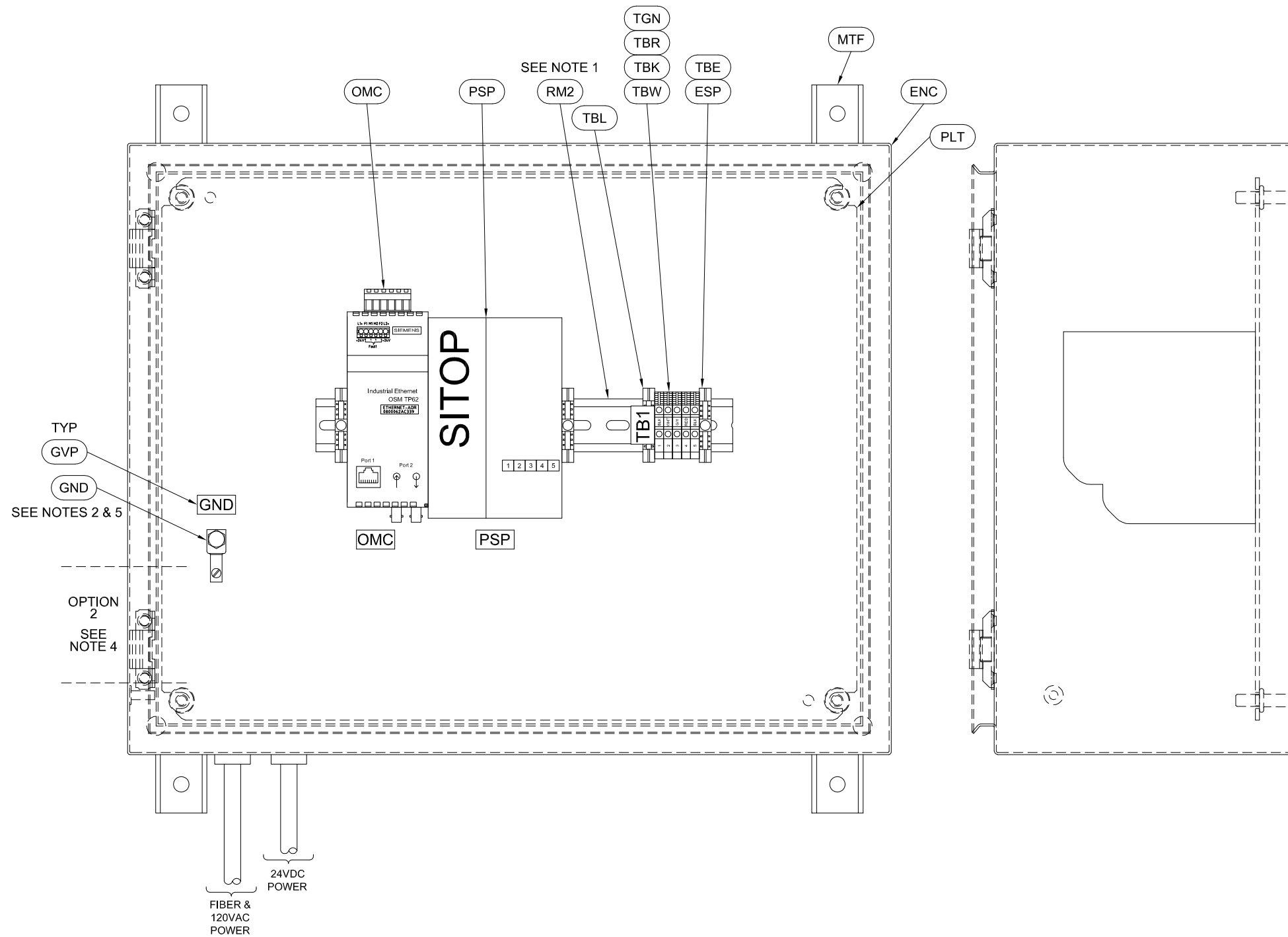

SEE NOTE 3

GENERAL BILL OF MATERIAL			
Item #	Description	U/M	QTY
UPS	UPS SMART 750VA USB XL 120V	EA	1
PSP	PLC POWER SUPPLY 120VAC IN 24VDC OUT 5A	EA	1
OMC	ETHERNET OPTICAL MEDIA CONVERTER S7-224	EA	1
MTF	MOUNTING FOOT KIT HOFFM ENCL	EA	1
ENC	ENCL 16H x 20W x 8D	EA	1
PLT	S7-224 TOWER PLC BACK PLATE	EA	1
GND	GROUND LUG	EA	1
TBE	TERM BLK END CLAMP 10mm	EA	3
TBL	TERM BLK END CLMP W/LABEL 10mm	EA	1
TGN	TRM BLK GND'NG GRN/YEL 24-12AWG 6mm	EA	1
TBW	TERM BLK 22-10AWG 600V WHITE	EA	1
TBK	TERM BLK 22-10AWG 600V BLACK	EA	2
TBR	TERM BLK 22-10AWG 600V RED	EA	1
ESP	END COVER, FOR PHNX UK5 & UK10 TERM. BLK	EA	1
W22	22AWG WIRE 600V 200C WHITE	FT	30
GVP	S7-224 TOWER PLC GRAVOPLY LABELS	EA	1
RM2	MTG RAIL 7.5MM U-SHAPE	IN	12

**ASSEMBLY NOTES:**

1. USE 8-32 SELF-TAPPING SCREWS TO MOUNT DIN RAIL.
2. MAKE SURE GROUND LUG MAKES CONTACT WITH BARE METAL OF PANEL. PANEL SHOULD BE MASKED OFF AT GROUND LUG BEFORE PAINTING. ATTACH LUG WITH 1/4-20 BOLT AND SPLIT WASHER.

**INSTALLATION NOTES:**

3. UPS TO BE INSTALLED WITHIN 10' (FEET) OF THE PLC ENCLOSURE. UPS POWER TO BE RUN FROM THE UPS AND TERMINATED AT TB1.
4. ALL ENCLOSURE PENETRATIONS TO BE MADE FROM THE BOTTOM LEFT SIDE OF ENCLOSURE AS SHOWN.
5. CONTRACTOR TO GROUND ENCLOSURE ACCORDING TO NEC AND LOCAL BUILDING CODES.

CONTROLLED COPY  
Unauthorized duplication of this document in whole or part is prohibited.  
Initiated in RED Ink below indicates authorized copy.

ASSOCIATED DRAWINGS:  
DRAWN BY:  
DRAWN DATE:

REV. DATE

DRAWN BY

REVISION DESCRIPTION

REV. LEVEL

REV. DATE

DRAWN BY

REVISION DESCRIPTION

REV. LEVEL

REV. DATE

DRAWN BY

REVISION DESCRIPTION

REV. LEVEL

REV. DATE

DRAWING TITLE:  
PLC AIRFIELD LIGHTING CONTROL SYSTEM  
S7-224 TOWER PLC ASSEMBLY

DRAWING NUMBER:  
PLCA-09

REV. B

DRAWN BY

REVISION DESCRIPTION

REV. LEVEL

REV. DATE

DRAWN BY

REVISION DESCRIPTION

REV. LEVEL

REV. DATE

DRAWN BY

REVISION DESCRIPTION

REV. LEVEL

REV. DATE

ADBE  
Airfield Solutions  
977 Galathea Parkway, Columbus, Ohio 43230  
Telephone: 614-861-1304, Fax: 614-864-2069

**CAUTION:**  
THIS DRAWING IS ONLY INTENDED FOR USE AS GENERAL AIRFIELD SYSTEM DESIGN GUIDANCE. THE DESIGNER MUST VERIFY DESIGN WITH LOCAL CODES AND VARYING CHARACTERISTICS FOR EACH UNIQUE AIRFIELD APPLICATION.

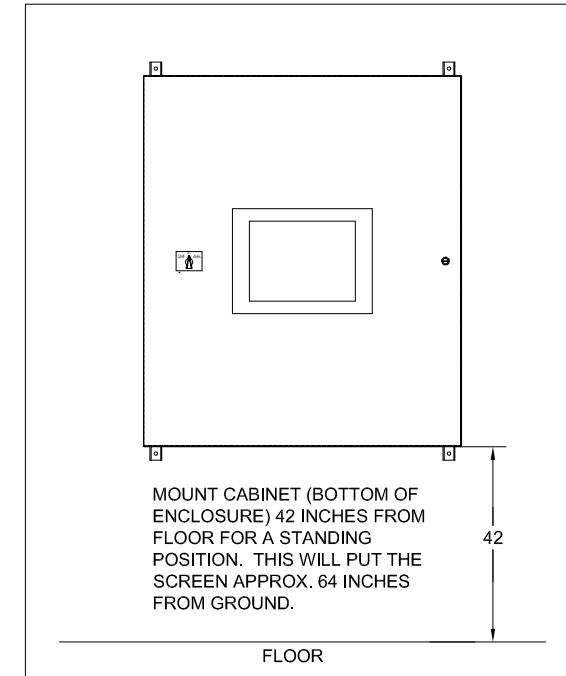
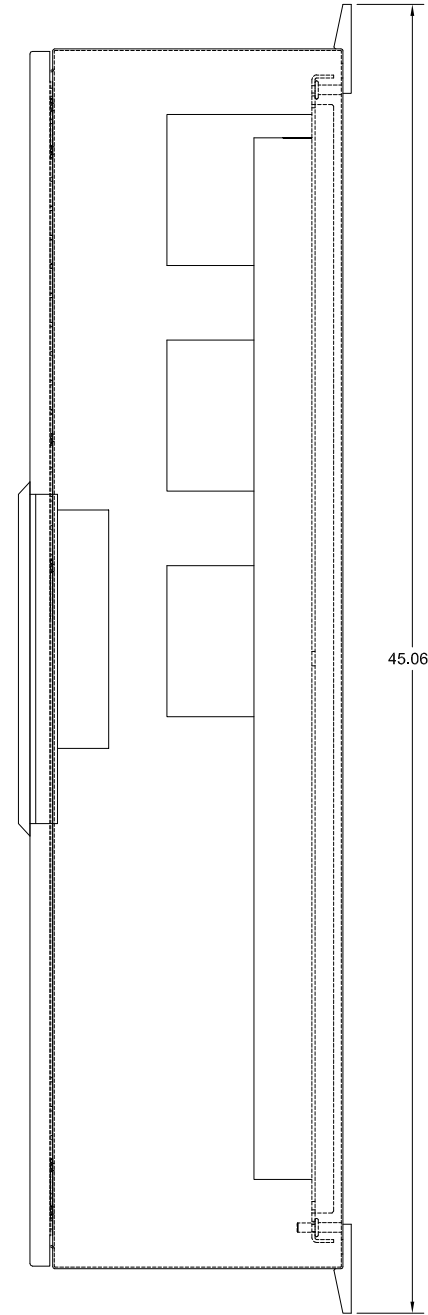
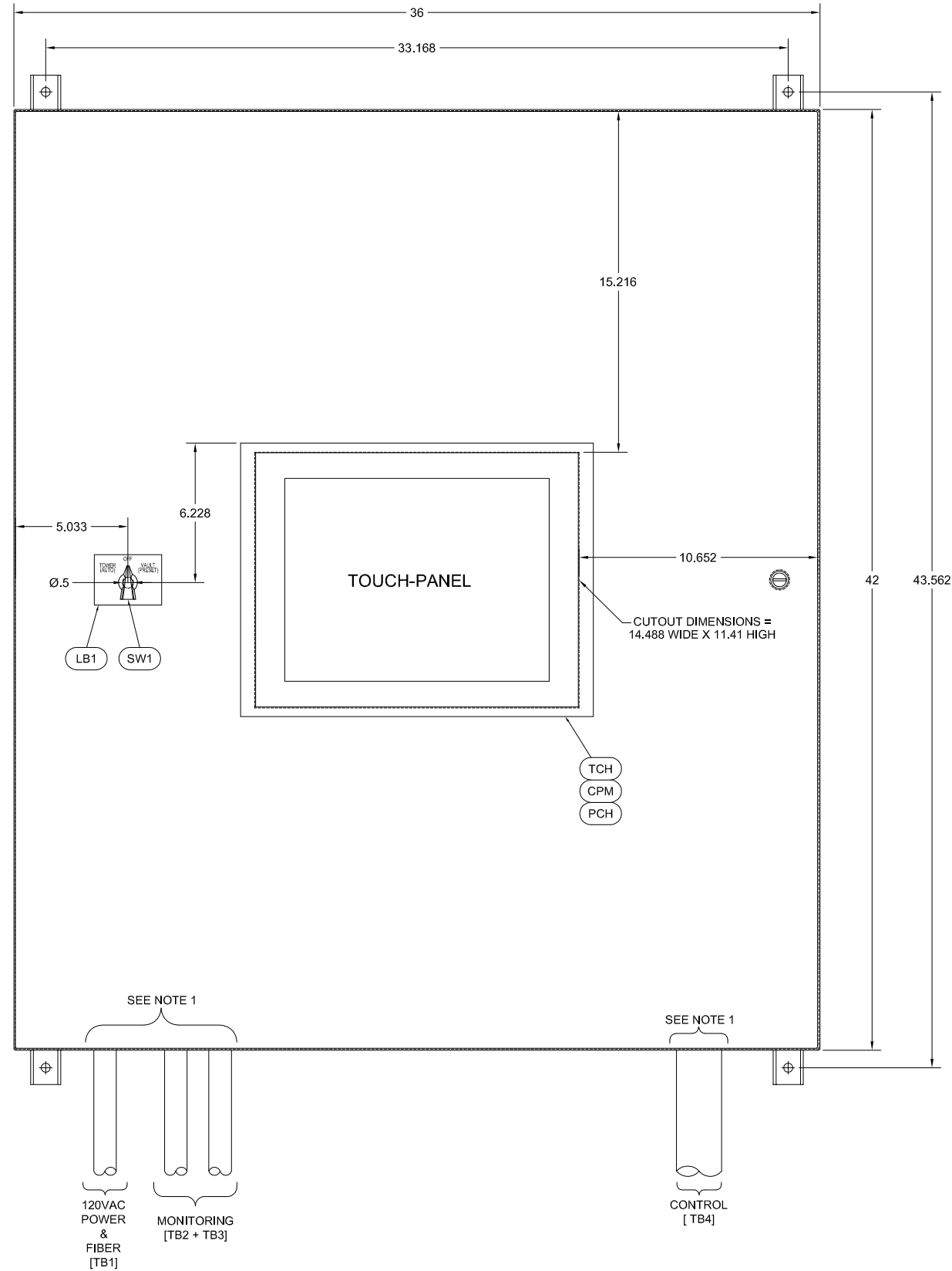

**INSTALLATION NOTES:**

1. ALL ENCLOSURE PENETRATIONS TO BE MADE IN BOTTOM OF ENCLOSURE AS SHOWN. CONDUIT QUANTITY AND SIZE MAY VARY BUT WIRING MUST BE SEPARATED AS INDICATED.
2. SEE INSTALLATION HEIGHT BELOW.

**CAUTION:**

THIS DRAWING IS ONLY INTENDED FOR USE AS GENERAL AIRFIELD SYSTEM DESIGN GUIDANCE. THE DESIGNER MUST VERIFY DESIGN WITH LOCAL CODES AND VARYING CHARACTERISTICS FOR EACH UNIQUE AIRFIELD APPLICATION.

DRAWING TITLE: PLC AIRFIELD LIGHTING CONTROL SYSTEM VAULT PLC ASSEMBLY		REV. <b>B</b>	
DRAWING NUMBER: <b>PLCA-10</b>		REV. LEVEL	
ASSOCIATED DRAWINGS: PLCA-11	INITIAL DATE:	REVISION DESCRIPTION	REV. DATE
<small>         All information contained herein, including illustrations, drawings, and schedules, is the property of ADB and is to be used only for the project and location specified. ADB reserves the right to make changes and improvements to its products and services without notice. ADB Airfield Solutions may otherwise agree to its wiring. Copyright © 2014 ADB Airfield Solutions.       </small>		REVISION DESCRIPTION	REV. DATE
<small>         Uncontrolled Copy          Uncontrolled duplication of this document in whole or part is prohibited. Initialed in RED ink below indicates authorized copy.       </small>		REVISION DESCRIPTION	REV. DATE
<small>         ADBE          Airfield Solutions          977 Galhanna Parkway, Columbus, Ohio 43230          Telephone: 614-861-1304, Fax: 614-864-2069       </small>		REVISION DESCRIPTION	REV. DATE



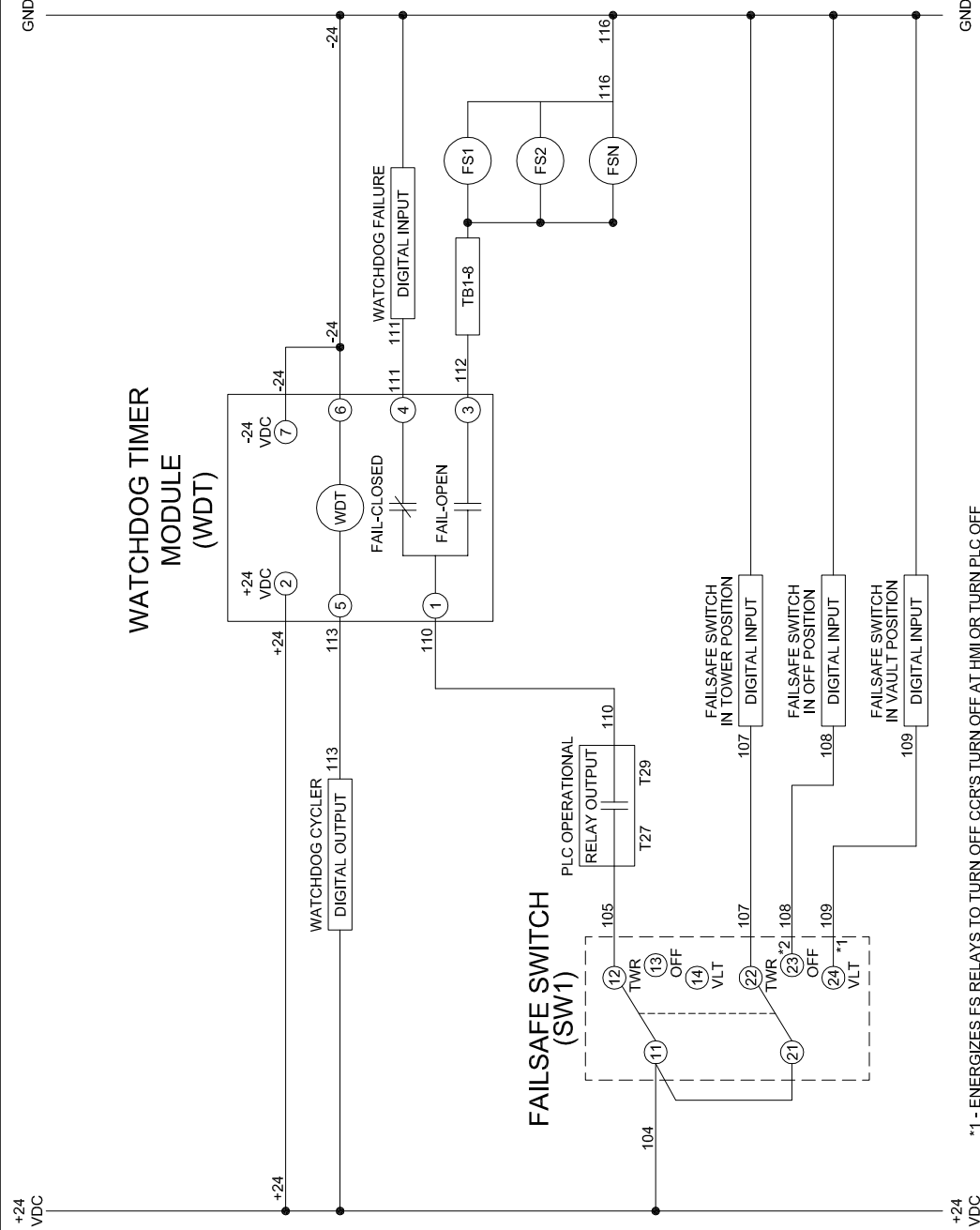

\*1 - ENERGIZES FS RELAYS TO TURN OFF CCR'S TURN OFF AT HMI OR TURN PLC OFF  
 \*2 - DE-ENERGIZES FS RELAYS, CCR'S WILL REVERT TO HARD-WIRE PRESET SETTING

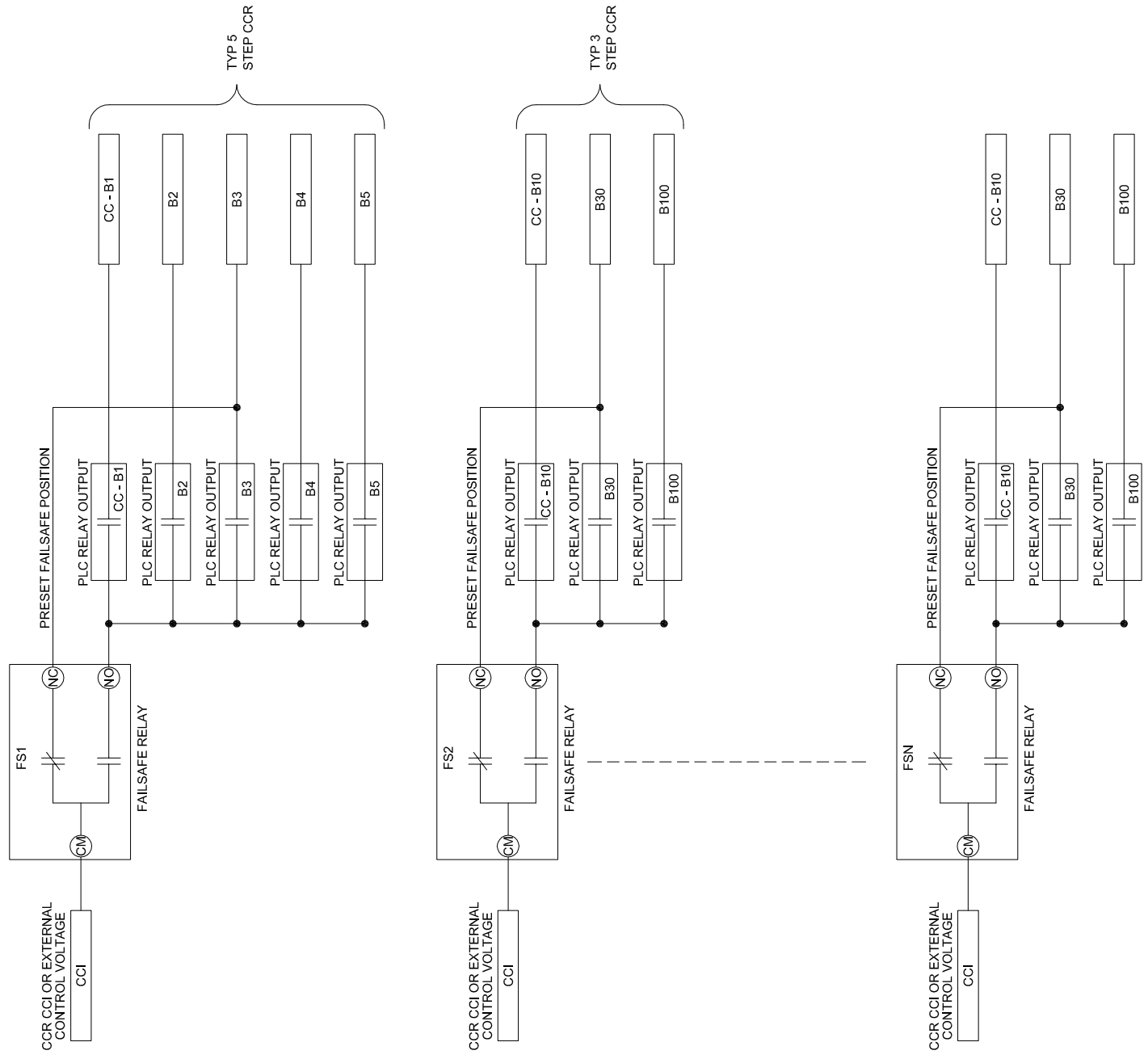

**FAILSAFE SENARIOS:**  
 LOSS COMM / PLC OK = LAST STATE FAILSAFE ENERGIZED  
 PLC FAILURE / WATCHDOG FAILURE = PRESET FAILSAFE  
 FAILSAFE SWITCH IN VAULT POSITION = VAULT IN LOCAL CONTROL  
 FAILSAFE SWITCH IN OFF POSITION = PRESET FAILSAFE

**CAUTION:**  
 THIS DRAWING IS ONLY INTENDED FOR USE AS GENERAL AIRFIELD SYSTEM DESIGN GUIDANCE. THE DESIGNER MUST VERIFY DESIGN WITH LOCAL CODES AND VARYING CHARACTERISTICS FOR EACH UNIQUE AIRFIELD APPLICATION.

DRAWING TITLE: PLC AIRFIELD LIGHTING CONTROL SYSTEM VAULT PLC ASSEMBLY LADDER LOGIC		REV. LEVEL	REV. DATE	REVISION DESCRIPTION	DRAWN BY	REV. DATE	REV. LEVEL	REVISION DESCRIPTION
		B						
DRAWING NUMBER: PLCA-12		ASSOCIATED DRAWINGS: PLCA-11						
		DRAWN BY:						
		DRAWN DATE:						
		INITIAL DATE:						
		All information contained herein, including illustrations, is the property of ADB Airfield Solutions, Inc. and is to be used as of the date of this publication, but is subject to change without notice. ADB reserves the right to make changes and improvements to its products and assumes no responsibility for these modifications. ADB Airfield Solutions may otherwise agree to in writing. Copyright © 2014 ADB Airfield Solutions.						
		CONTROLLED COPY Unauthorized duplication of this document in whole or part is prohibited. Initialed in RED ink below indicates authorized copy.						
		ADBE Airfield Solutions 977 Galathea Parkway, Columbus, Ohio 43230 Telephone: 614-861-1304, Fax: 614-864-2069						