



F-Range Type L-852T Style 2 Inset Light  
ITEL Taxiway Light

## Spare Parts

SP\_2042, Rev. A, 2020/06/15

  
**ADB  
SAFEGATE**



## A.0 Disclaimer / Standard Warranty

### CE certification

The equipment listed as CE certified means that the product complies with the essential requirements concerning safety and hygiene. The European directives that have been taken into consideration in the design are available on written request to ADB SAFEGATE.

### ETL certification

The equipment listed as ETL certified means that the product complies with the essential requirements concerning safety and FAA Airfield regulations. The FAA directives that have been taken into consideration in the design are available on written request to ADB SAFEGATE.

### All Products Guarantee

ADB SAFEGATE will correct by repair or replacement per the applicable guarantee above, at its option, equipment or parts which fail because of mechanical, electrical or physical defects, provided that the goods have been properly handled and stored prior to installation, properly installed and properly operated after installation, and provided further that Buyer gives ADB SAFEGATE written notice of such defects after delivery of the goods to Buyer. Refer to the Safety section for more information on Material Handling Precautions and Storage precautions that must be followed.

ADB SAFEGATE reserves the right to examine goods upon which a claim is made. Said goods must be presented in the same condition as when the defect therein was discovered. ADB SAFEGATE further reserves the right to require the return of such goods to establish any claim.

ADB SAFEGATE's obligation under this guarantee is limited to making repair or replacement within a reasonable time after receipt of such written notice and does not include any other costs such as the cost of removal of defective part, installation of repaired product, labor or consequential damages of any kind, the exclusive remedy being to require such new parts to be furnished.

ADB SAFEGATE's liability under no circumstances will exceed the contract price of goods claimed to be defective. Any returns under this guarantee are to be on a transportation charges prepaid basis. For products not manufactured by, but sold by ADB SAFEGATE, warranty is limited to that extended by the original manufacturer. This is ADB SAFEGATE's sole guarantee and warranty with respect to the goods; there are no express warranties or warranties of fitness for any particular purpose or any implied warranties of fitness for any particular purpose or any implied warranties other than those made expressly herein. All such warranties being expressly disclaimed.

### Standard Products Guarantee

Products of ADB SAFEGATE manufacture are guaranteed against mechanical, electrical, and physical defects (excluding lamps) which may occur during proper and normal use for a period of two years from the date of ex-works delivery, and are guaranteed to be merchantable and fit for the ordinary purposes for which such products are made.



#### Note

See your sales order contract for a complete warranty description.

### FAA Certified product installed in the United States and purchased or funded with monies through the Airport Improvement Program (AIP) installations guarantee

ADB SAFEGATE L858 Airfield Guidance Signs are warranted against mechanical and physical defects in design or manufacture for a period of 2 years from date of installation, per FAA AC 150/5345-44 (applicable edition).

ADB SAFEGATE L858(L) Airfield Guidance Signs are warranted against electrical defects in design or manufacture of the LED or LED specific circuitry for a period of 4 years from date of installation, per FAA EB67 (applicable edition).

ADB SAFEGATE LED light fixtures (with the exception of obstruction lighting) are warranted against electrical defects in design or manufacture of the LED or LED specific circuitry for a period of 4 years from date of installation, per FAA EB67 (applicable edition).



## Note

See your sales order contract for a complete warranty description.

---

## Liability

---



### WARNING

Use of the equipment in ways other than described in the catalog leaflet and the manual may result in personal injury, death, or property and equipment damage. Use this equipment only as described in the manual.

---

ADB SAFEGATE cannot be held responsible for injuries or damages resulting from non-standard, unintended uses of its equipment. The equipment is designed and intended only for the purpose described in the manual. Uses not described in the manual are considered unintended uses and may result in serious personal injury, death or property damage.

Unintended uses, includes the following actions:

- Making changes to equipment that have not been recommended or described in this manual or using parts that are not genuine ADB SAFEGATE replacement parts or accessories.
- Failing to make sure that auxiliary equipment complies with approval agency requirements, local codes, and all applicable safety standards if not in contradiction with the general rules.
- Using materials or auxiliary equipment that are inappropriate or incompatible with your ADB SAFEGATE equipment.
- Allowing unskilled personnel to perform any task on or with the equipment.

## © ADB SAFEGATE BV

This manual or parts thereof may not be reproduced, stored in a retrieval system, or transmitted, in any form or by any means, electronic, mechanical, photocopying, recording, nor otherwise, without ADB SAFEGATE BV's prior written consent.

This manual could contain technical inaccuracies or typographical errors. ADB SAFEGATE BV reserves the right to revise this manual from time to time in the contents thereof without obligation of ADB SAFEGATE BV to notify any person of such revision or change. Details and values given in this manual are average values and have been compiled with care. They are not binding, however, and ADB SAFEGATE BV disclaims any liability for damages or detriments suffered as a result of reliance on the information given herein or the use of products, processes or equipment to which this manual refers. No warranty is made that the use of the information or of the products, processes or equipment to which this manual refers will not infringe any third party's patents or rights. The information given does not release the buyer from making their own experiments and tests.

# TABLE OF CONTENTS

<b>1.0 Safety</b> .....	<b>1</b>
1.1 Safety Messages .....	1
1.1.1 Introduction to Safety .....	2
1.1.2 Intended Use .....	2
1.1.3 Material Handling Precautions: Storage .....	3
1.1.4 Material Handling Precautions: Fasteners .....	3
1.1.5 Operation Safety .....	4
1.1.6 Maintenance Safety .....	4
1.1.7 Arc Flash and Electric Shock Hazard .....	5
<b>2.0 ITEL</b> .....	<b>7</b>
2.1 Product Introduction .....	7
2.2 Incandescent In-pavement Taxiway Edge Light .....	7
2.3 Optical Unit .....	8
2.3.1 Inner Pan Subassembly .....	10
2.3.2 Lamp and Reflector Holder Assembly .....	11
2.3.3 Optional Film Disc Cutout .....	12
2.3.4 F-Range L-852T Light Fixture: Required Equipment .....	12
2.3.5 Lamp .....	12
2.3.6 Isolation Transformers .....	13
<b>3.0 Installation</b> .....	<b>15</b>
3.1 Overview of Sequence of Work .....	15
3.2 Typical L-868 Assembly .....	16
3.3 Safety Considerations .....	17
3.4 Verify Input Requirements and Equipment Needed .....	17
3.5 Unpack the unit .....	18
3.6 Inspect on delivery .....	18
3.7 Store .....	18
3.8 Installation on L-868 Base .....	18
3.9 Torquing and Installation Guidance for In-pavement Fixtures .....	20
3.10 Shallow base can installation .....	21
3.10.1 Installation on a Shallow Base .....	21
<b>4.0 Maintenance</b> .....	<b>23</b>
4.1 Maintenance Schedule .....	23
4.2 Replacing Lamp .....	23
4.3 Maintenance Procedures .....	24
4.4 Cleaning Lens .....	24
4.5 Removing L-868 Base Water .....	24
4.6 Lifting Optical Unit Out of Base .....	24
<b>5.0 Troubleshooting</b> .....	<b>27</b>
5.1 Troubleshooting Procedures .....	27
5.2 Repair .....	27
5.2.1 Opening Optical Unit .....	28
5.2.2 Replacing Lamp and Reflector Holder Assembly .....	30
5.2.3 Replacing Lamp .....	30
5.2.4 Replacing Lamp Spring .....	31
5.2.5 Replacing Lens .....	32
5.2.6 Replacing L-823 Cordset .....	35
5.2.7 Replacing Anti- Rotation Pins .....	37
5.2.8 Closing Optical Unit .....	38
5.2.9 Testing for Leaks .....	39
5.3 Material Handling Precautions: Fasteners .....	41
5.4 Bolt Torque Preventive Maintenance Schedule .....	42

<b>6.0 Parts</b> .....	<b>45</b>
6.1 Parts Diagrams .....	45
6.1.1 F-Range Optical Assembly Parts List .....	46
6.2 Spare Parts .....	46
<b>A.0 SUPPORT</b> .....	<b>49</b>
A.1 ADB SAFEGATE Website .....	49
A.2 Recycling .....	50
A.2.1 Local Authority Recycling .....	50
A.2.2 ADB SAFEGATE Recycling .....	50

# 1.0 Safety

## Introduction to Safety

This section contains general safety instructions for installing and using ADB SAFEGATE equipment. Some safety instructions may not apply to the equipment in this manual. Task- and equipment-specific warnings are included in other sections of this manual where appropriate.

## 1.1 Safety Messages

### HAZARD Icons used in the manual

For all HAZARD symbols in use, see the Safety section. All symbols must comply with ISO and ANSI standards.

Carefully read and observe all safety instructions in this manual, which alert you to safety hazards and conditions that may result in personal injury, death or property and equipment damage and are accompanied by the symbol shown below.



**WARNING**

Failure to observe a warning may result in personal injury, death or equipment damage.



**DANGER - Risk of electrical shock or ARC FLASH**

Disconnect equipment from line voltage. Failure to observe this warning may result in personal injury, death, or equipment damage. ARC Flash may cause blindness, severe burns or death.



**WARNING - Wear personal protective equipment**

Failure to observe may result in serious injury.



**WARNING - Do not touch**

Failure to observe this warning may result in personal injury, death, or equipment damage.



**CAUTION**

Failure to observe a caution may result in equipment damage.

### Qualified Personnel



**Important Information**

The term **qualified personnel** is defined here as individuals who thoroughly understand the equipment and its safe operation, maintenance and repair. Qualified personnel are physically capable of performing the required tasks, familiar with all relevant safety rules and regulations and have been trained to safely install, operate, maintain and repair the equipment. It is the responsibility of the company operating this equipment to ensure that its personnel meet these requirements.

Always use required personal protective equipment (PPE) and follow safe electrical work practice.

### 1.1.1 Introduction to Safety



#### CAUTION

##### Unsafe Equipment Use

This equipment may contain electrostatic devices, hazardous voltages and sharp edges on components

- Read installation instructions in their entirety before starting installation.
- Become familiar with the general safety instructions in this section of the manual before installing, operating, maintaining or repairing this equipment.
- Read and carefully follow the instructions throughout this manual for performing specific tasks and working with specific equipment.
- Make this manual available to personnel installing, operating, maintaining or repairing this equipment.
- Follow all applicable safety procedures required by your company, industry standards and government or other regulatory agencies.
- Install all electrical connections to local code.
- Use only electrical wire of sufficient gauge and insulation to handle the rated current demand. All wiring must meet local codes.
- Route electrical wiring along a protected path. Make sure they will not be damaged by moving equipment.
- Protect components from damage, wear, and harsh environment conditions.
- Allow ample room for maintenance, panel accessibility, and cover removal.
- Protect equipment with safety devices as specified by applicable safety regulations
- If safety devices must be removed for installation, install them immediately after the work is completed and check them for proper functioning prior to returning power to the circuit.

**Failure to follow this instruction can result in serious injury or equipment damage**

### Additional Reference Materials



#### Important Information

- IEC - International Standards and Conformity Assessment for all electrical, electronic and related technologies.
- IEC 60364 - Electrical Installations in Buildings.
- FAA Advisory: AC 150/5340-26 (current edition), Maintenance of Airport Visual Aid Facilities.
- Maintenance personnel must refer to the maintenance procedure described in the ICAO Airport Services Manual, Part 9.
- ANSI/NFPA 79, Electrical Standards for Metalworking Machine Tools.
- National and local electrical codes and standards.

### 1.1.2 Intended Use



#### CAUTION

##### Use this equipment as intended by the manufacturer

This equipment is designed to perform a specific function, do not use this equipment for other purposes

- Using this equipment in ways other than described in this manual may result in personal injury, death or property and equipment damage. Use this equipment only as described in this manual.

**Failure to follow this instruction can result in serious injury or equipment damage**



### 1.1.3 Material Handling Precautions: Storage



#### CAUTION

##### Improper Storage

Store this equipment properly

- If equipment is to be stored prior to installation, it must be protected from the weather and kept free of condensation and dust.

**Failure to follow this instruction can result in equipment damage**

### 1.1.4 Material Handling Precautions: Fasteners



#### DANGER

##### Foreign Object Damage - FOD

This equipment may contain fasteners that may come loose - torque properly.

- Only use fasteners of the same type as the one originally supplied with the equipment.
- Use of incorrect combination of gaskets, bolts and nuts can create severe damages to the product installation and create safety risk .
- You need to know what base the light fixture will be installed in, in order to chose the correct gasket, bolts and nuts.
- Bolt type, length, and torque value are determined by type of base, height of spacers used, and clamp force required in FAA Engineering Brief No 83 (latest revision).
- Due to the risk of bolts vibrating loose, do not use any type of washer with the fixing bolts (such as split lock washers) other than an anti-vibration washer. Anti-vibration washers as defined in FAA EB 83 (latest edition) must be used. For installations other than FAA, use the base can manufacturer's recommendations.
- Always tighten the fasteners to the recommended torque. Use a calibrated torque wrench and apply the recommended adhesive type.
- Obey the instructions of the adhesives necessary for the fasteners.

**Failure to follow these warnings may cause the fasteners to loosen, damage the equipment, potentially to loosen the equipment. This can lead to a highly dangerous situation of FOD, with potential lethal consequences.**



#### Note

To minimize the risk of errors, the ADB SAFEGATE Sales Representative will have information on which gasket goes with which base. This information is also provided in the product Data sheets, the User Manuals and the Spare Part Lists.



#### CAUTION

Use of incorrect combination of gaskets, bolts and nuts can create severe damages to the product installation and create multiple safety risks.

To obtain a safe and watertight installation the O-ring and retaining bolt stated in the document must be used.

You need to know what base the light fixture will be installed in, in order to choose the correct gasket, bolts and nuts.

**Failure to follow these cautions can result in equipment damage or aircraft FOD.**

### 1.1.5 Operation Safety



#### CAUTION

##### **Improper Operation**

Do Not Operate this equipment other than as specified by the manufacturer

- Only qualified personnel, physically capable of operating the equipment and with no impairments in their judgment or reaction times, should operate this equipment.
- Read all system component manuals before operating this equipment. A thorough understanding of system components and their operation will help you operate the system safely and efficiently.
- Before starting this equipment, check all safety interlocks, fire-detection systems, and protective devices such as panels and covers. Make sure all devices are fully functional. Do not operate the system if these devices are not working properly. Do not deactivate or bypass automatic safety interlocks or locked-out electrical disconnects or pneumatic valves.
- Protect equipment with safety devices as specified by applicable safety regulations.
- If safety devices must be removed for installation, install them immediately after the work is completed and check them for proper functioning.
- Route electrical wiring along a protected path. Make sure they will not be damaged by moving equipment.
- Never operate equipment with a known malfunction.
- Do not attempt to operate or service electrical equipment if standing water is present.
- Use this equipment only in the environments for which it is rated. Do not operate this equipment in humid, flammable, or explosive environments unless it has been rated for safe operation in these environments.
- Never touch exposed electrical connections on equipment while the power is ON.

**Failure to follow these instructions can result in equipment damage**

### 1.1.6 Maintenance Safety



#### DANGER

##### **Electric Shock Hazard**

This equipment may contain electrostatic devices

- Do not operate a system that contains malfunctioning components. If a component malfunctions, turn the system OFF immediately.
- Disconnect and lock out electrical power.
- Allow only qualified personnel to make repairs. Repair or replace the malfunctioning component according to instructions provided in its manual.

**Failure to follow these instructions can result in death or equipment damage**

### 1.1.7 Arc Flash and Electric Shock Hazard



## DANGER

### Series Circuits have Hazardous Voltages

This equipment produces high voltages to maintain the specified current - Do NOT Disconnect while energized.

- Allow only qualified personnel to perform maintenance, troubleshooting, and repair tasks.
- Only persons who are properly trained and familiar with ADB SAFEGATE equipment are permitted to service this equipment.
- An open airfield current circuit is capable of generating >5000 Vac and may appear OFF to a meter.
- Never unplug a device from a constant current circuit while it is operating; Arc flash may result.
- Disconnect and lock out electrical power.
- Always use safety devices when working on this equipment.
- Follow the recommended maintenance procedures in the product manuals.
- Do not service or adjust any equipment unless another person trained in first aid and CPR is present.
- Connect all disconnected equipment ground cables and wires after servicing equipment. Ground all conductive equipment.
- Use only approved ADB SAFEGATE replacement parts. Using unapproved parts or making unapproved modifications to equipment may void agency approvals and create safety hazards.
- Check the interlock systems periodically to ensure their effectiveness.
- Do not attempt to service electrical equipment if standing water is present. Use caution when servicing electrical equipment in a high-humidity environment.
- Use tools with insulated handles when working with airfield electrical equipment.

**Failure to follow these instructions can result in death or equipment damage**



## 2.0 ITEL

Description: Provides users with a rapid reference source for determining the purpose, physical and functional characteristics, operational capabilities, and limitations of the equipment. Also see the ADB Safegate Web site for more info.  
[www.adbsafegate.com](http://www.adbsafegate.com)



12" Fixture

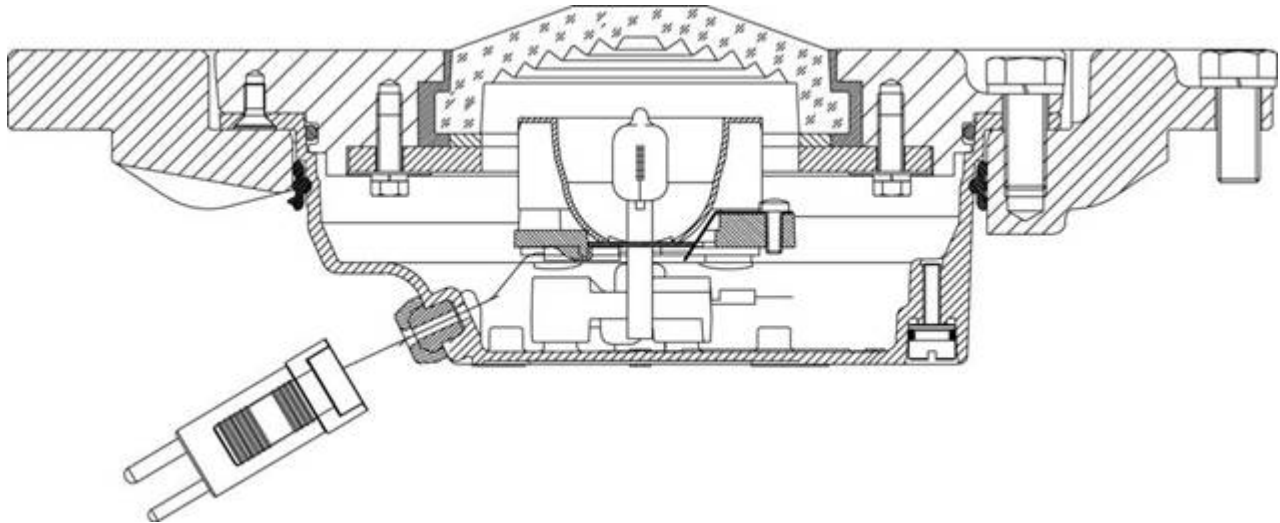
### 2.1 Product Introduction

1. Become familiar with the structure and content.
2. Carry out the actions completely and in the given sequence.

This section describes the ADB Airfield Solutions F-Range Type L-852T, Style 2 inset light. The L-852T is used on a runway to mark the extension line of the taxiway elevated fixtures through the intersection of the taxiway with the runway.

See [Figure 1](#) The L-852T F-Range inset light fixtures is designed to provide visual guidance along the taxiway and runway. It is manufactured in accordance with FAA specification AC 150/5345-46, Style 2 (1 1/2 inch Height Above Grade).

**Figure 1: Cutaway View of L-852T F-Range Inset Light Fixture**



### 2.2 Incandescent In-pavement Taxiway Edge Light

#### Compliance with Standards

---

**FAA:** L-852T AC 150/5345-46 (Current Edition).

---

## Uses

### FAA L-852T

- Taxiway edge
- Helipads
  - Yellow for military and existing civilian applications

## Features

- FAA Style 2—Low protrusion above ground of  $\leq 0.5$  inch reduces vibration caused by aircraft landing gear in both the light fixture and landing gear, increasing lamp life
- Designed and built with simplicity and ease of maintenance in mind
- Hardened, colored glass lens
- Low-energy/long-life halogen lamps are 45 W with a rated life of more than 1,000 hours at full intensity and in excess of 3,000 hours in practical use
- Fixture uses aluminum alloy cover, inner cover, and optical assembly, and stainless steel hardware
- Includes a UL 467 rated ground lug, which accepts an AWG 6 earth ground wire

## Electrical Supply

6.6A through an L-830 or a series isolation transformer. Two or more fittings may be series-connected and fed from an isolation transformer, making use of optional film disc or electronic cutouts.

## Optional Snow Plow Ring

Use caution during snowplow conditions. A rubber tip blade is recommended. Depending on installation method and snow plowing technique used, a snow plow ring may be necessary. Snow plow rings are available for either standard or stainless steel adjustable Size B L-868 cans. Contact the ADB Sales Department for additional details.

## Packaging

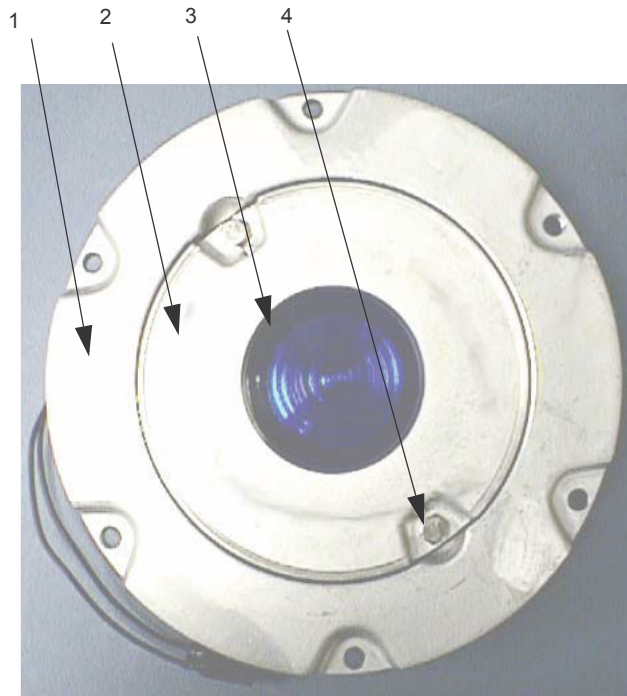
In cardboard box:	7 × 13 × 13 in (17.8 × 33 × 33 cm)
Weight with packing:	15.3 lb (6.94 kg)
Weight without packing:	12.3 lb (5.58 kg)

## 2.3 Optical Unit

See [Figure 2](#) for top view of the optical unit with adapter ring and [Figure 3](#) for a bottom view of the optical unit. See [Figure 4](#) for the lamp and reflector.

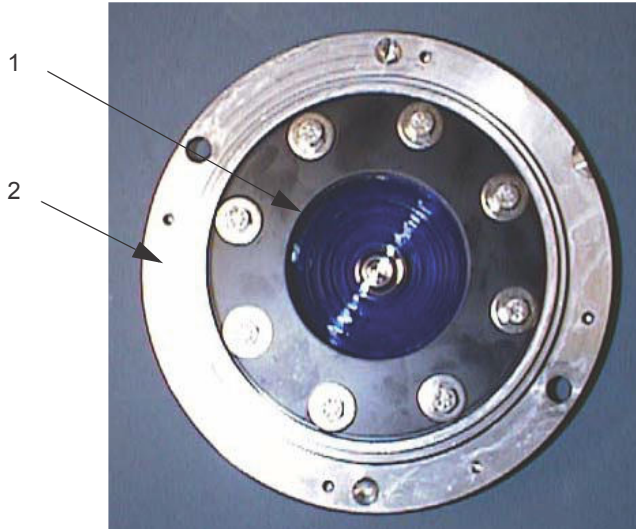
The F-Range series light fixture optical unit consists of one 6.6 A/45 W PKX30d or 6.6 A/65 W PKX30d lamp and blue, red, or yellow colored omnidirectional lenses.

**Figure 2: L-852T Optical Unit with Adapter Ring (Top View)**



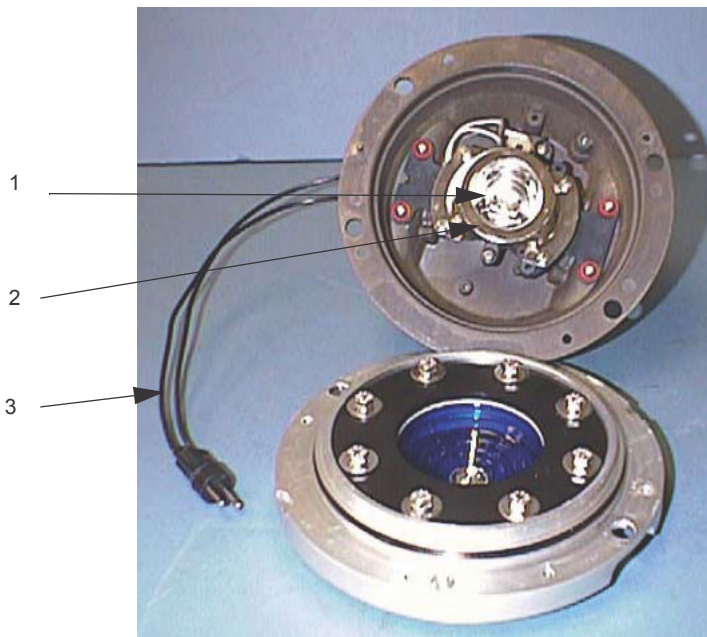
1. Adapter Ring
2. L-852T Optical Assembly
3. Lens
4. Inner Mounting Bolts

**Figure 3: L-852T Optical Unit without Adapter Ring (Bottom View)**



1. Lens
2. Optical Assembly Top Cover

**Figure 4: L-852T Lamp and Reflector**



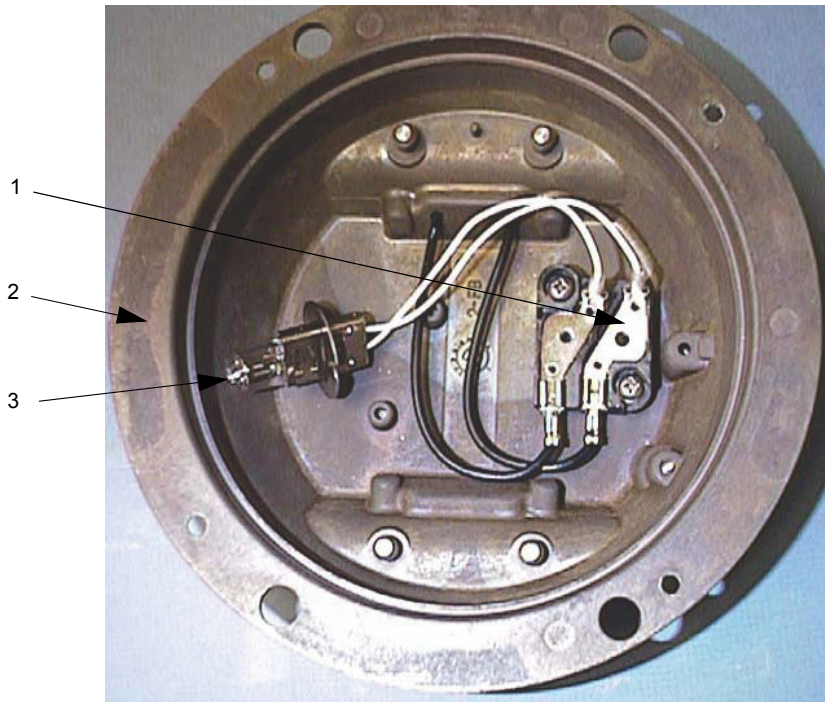
1. Lamp
2. Reflector
3. Cordset

### 2.3.1 Inner Pan Subassembly

See [Figure 5](#). The inner cover assembly is comprised of the inner cover (2), L-823 cordset(s) (see [Figure 4](#), Item 3), terminal block(s) (1) (with or without film disc cutout), and pressure release screw.



**Figure 5: Inner Pan Subassembly**

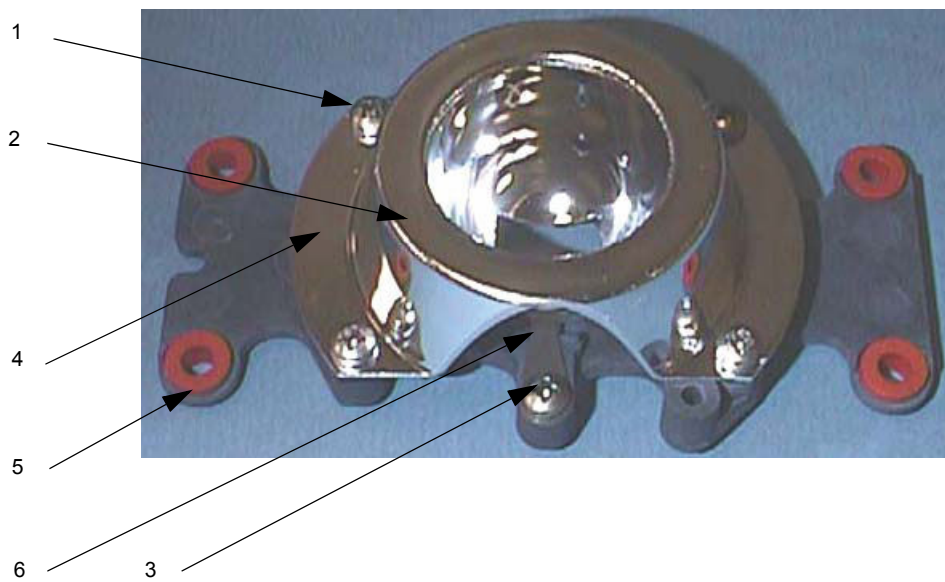


- 1. Terminal Blocks
- 2. Inner Cover
- 3. Lamp

**2.3.2 Lamp and Reflector Holder Assembly**

See [Figure 6](#) The lamp and reflector holder assembly is pre-assembled at the factory.

**Figure 6: Lamp and Reflector Holder Assembly**



- 1. Lamp and Reflector Holder Assembly Screws
- 2. Lamp Reflector

3. Lamp Spring Screw
4. Lamp and Reflector Holder Assembly
5. Grommet
6. Lamp Spring

### 2.3.3 Optional Film Disc Cutout

See [Figure 5](#). An optional film disc cutout (1) is available as an electrical bypass device in case of lamp failure. It closes an auxiliary circuit around the lamp within 15 seconds after lamp failure. The film disc cutout shorts and completes the circuit when the lamp fails. This allows the other lamps to remain lighted in series-connected fixtures. It also prevents excessive volt amperes on the secondary of the isolation transformer. The film disc cutout must be replaced (if used) when the lamp is replaced. Refer to *Replacing Film Disc Cutout Assembly* in the *Repair* section.

---



#### CAUTION

Read installation instructions in their entirety before starting installation or maintenance.

Do not use a film disc cutout if circuit has monitoring. This will prevent the monitoring system from functioning properly

---

### 2.3.4 F-Range L-852T Light Fixture: Required Equipment

Refer to [Table 1](#) for required equipment that is supplied. Refer to [Table 2](#) for required equipment that is not supplied. Refer to the *Parts* section for part numbers.

**Table 1: Required Equipment Supplied**

Description	Quantity
F-Range L-852T inset light, with lamp	1
Instruction manual	1 per order

---

**Table 2: Required Equipment Not Supplied**

Description	Quantity
Torque wrench	1
Alignment jig	1
Diamond-faced core drill, 13 in. (330 mm diameter)	1
Diamond-faced saw, 3/8 in. (9.525 mm) thick	1
Crimping tool	1
Small water suction pump	1
L-830 isolation transformer	1 or 2
Eyebolt, 3/8 in. (9.525 mm) diameter	2
Lifting rod, 16 in. (406 mm) long	1
Set of fiber brushes	1
Set of socket wrenches, 1/2 in. (12.7 mm) drive	1
Set of screwdrivers, one with 3/8 in. (9.525 mm) minimum blade width	1
Silicone grease	As required
Joint sealing filler	As required

---

### 2.3.5 Lamp

---

### 2.3.6 Isolation Transformers



---

## 3.0 Installation

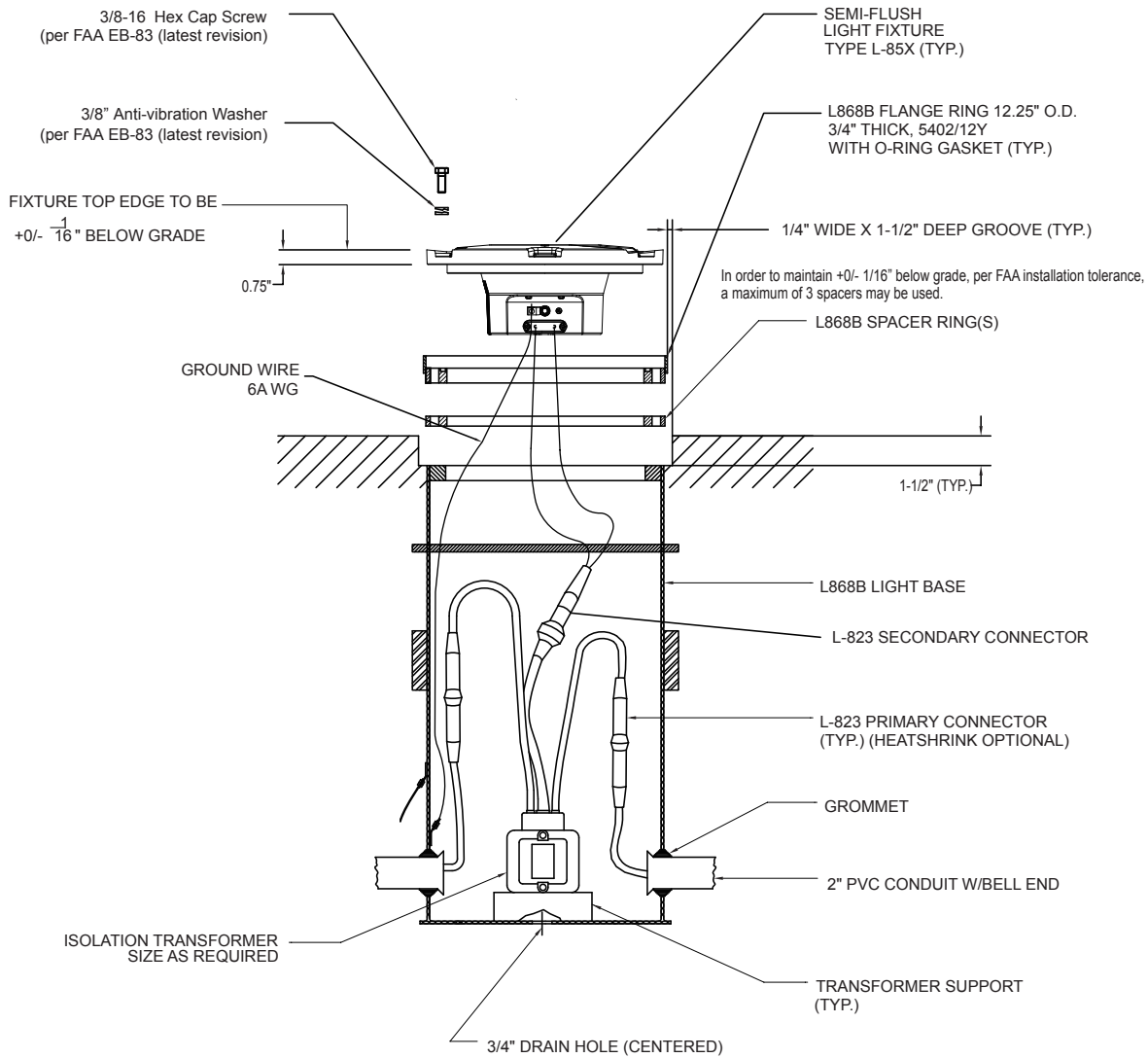
This section provides instructions for installing the L-852T F-Range inset lights. Refer to airport project plans and specifications for the specific installation instructions. The installation shall conform to the applicable sections of the National Electric Code and local codes. Also see FAA Advisory Circular , AC 150/5345-30 for additional installation instructions.

### 3.1 Overview of Sequence of Work

- Electrical contractor locates new light bases and interconnecting conduit trench, and excavates for light base bottom section by saw cutting or core drilling. Electrical contractor prepares subgrade and stone subbase, sets bottom section with rebar, rigid steel conduit stubs, drain, and pours high early strength concrete-encasement excavation. Electrical contractor shall record can locations and elevations of mud plate after concrete-encasement.
- Electrical contractor excavates conduit trench, installs rigid steel and fittings, backfills conduit trench with high early strength concrete.
- General contractor prepares and installs concrete pavement. Electrical contractor makes a pilot core to find mud plate center point indent before final core-drilling.
- Electrical contractor core-drills concrete pavement. Electrical contractor installs top section, y-flange ring, space and lighting fixture, and pours epoxy joint sealer. Provide space for adjustment with spacers, maximum number of spacers shall be 3.
- See specific details as shown in FAA AC 150/5340-30 (current edition).

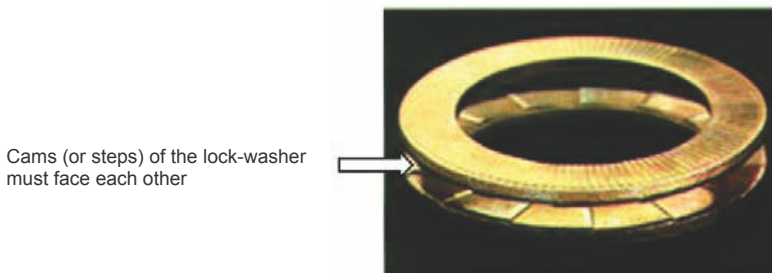
### 3.2 Typical L-868 Assembly

**Figure 7: Diagram of the Fixture Installed in a 1-Piece Base Can**



1. Torque according to: FAA EB-83 (latest revision).

**Figure 8: Anti-vibration washer example**





### CAUTION

Per FAA AC 150/5340-30, Chapter 10, and FAA Engineering Brief No 83 (latest revision), it is extremely important that other types of washers, such as split washers, must not be used. Failure to use properly installed anti-vibration lock washers will cause mounting bolts to become loose. The cams (or steps) of each half of the lock washer must face each other.

## 3.3 Safety Considerations

Read the installation section of all system component manuals before starting these steps. A thorough understanding of system components and their requirements will promote safe and efficient installation. See FAA AC 150/5340-30, Design and Installation Details for Airport Visual Aids, and site plans and specifications for field installation of runway and taxiway in-pavement lights.



### CAUTION

Failure to follow these safety procedures can result in personal injury or death.

- Allow only qualified personnel to install ADB SAFEGATE and auxiliary equipment. Use only approved equipment. Using unapproved equipment in an approved system may void FAA approvals. Observe and follow the safety instructions in this document and all other related documentation.
- Make sure all equipment is rated and approved for the environment where it is being used.
- Follow all instructions for installing components and accessories.
- Install all electrical connections in compliance with local and national codes and regulations.
- Use only electrical wire of sufficient gauge and insulation to handle the rated current demand. All wiring must meet local and national codes.
- Route electrical wiring along a protected path. Make sure it will not be damaged by moving equipment.
- Protect components from damage, wear and harsh environmental conditions.
- Allow ample clearance for maintenance, panel accessibility and cover removal.
- Protect equipment with safety devices as specified by applicable safety regulations.
- If safety devices must be removed for installation, reinstall them immediately after the work is completed and check them for proper functioning.
- The cord set must be protected prior to installation.

## 3.4 Verify Input Requirements and Equipment Needed

The In-pavement light fixture is designed for connection to a 6.6A or 20A series lighting circuit via an L-830 (60 Hz) or L-831 (50 Hz) isolation transformer.

Make sure you have the necessary tools and materials ready for installation (not supplied). Also consider other tools that might be needed based on site-specific conditions.

**Table 3: Suggested Tools and Materials for Installation and Repair**

Qty.	Description	Qty.	Description
1	Torque wrench	1	Set of screwdrivers, one with 3/8" (9.525mm) minimum blade width
1	Alignment jig		
1	Diamond-faced core drill	As needed	Silicone grease
1	Diamond-faced saw, 3/8" (9.525mm) thick	As needed	Joint sealing filler
1	Crimping tool	1	Pressure test fitting assembly

**Table 3: Suggested Tools and Materials for Installation and Repair (continued)**

1	Small water suction pump	As needed	Dow Corning Molykote® 3452 or equal (P/N 67A0095) - used on top cover prism seal
2	Eyebolts, 3/8 inch (9.525mm) diameter		
1	Lifting rod, 16 inches (406mm) long	As needed	Novagard® Silicone Versilube® G322L™ (P/N 67A0009) - used on O-ring between top cover and inner pan assembly; also may be applied to four nipples of inner pan assembly to install optical assembly
1 or 2	L-830 / L-831 isolation transformer		
1	Set of fiber brushes		
1	Set of socket wrenches, 1/2" (12.7mm) drive		

### 3.5 Unpack the unit

To reduce the possibility of damaging the light assembly, unpack the RELIANCE light fixtures at the installation site. If damage to any equipment is noted, file a claim form with the carrier immediately.

When receiving the light fixture, open the box and verify that the characteristics of the light fixture correspond to the design requirements, such as type, color etc. When installing an IQ0 light fixture where the function is to be activated at a later stage, make sure to register product information, such as PID/SN and position of the light fixture in, for example, a site documentation table. The information is required for remote activation and administration of IQ functionality from a substation.

### 3.6 Inspect on delivery

1. Inspect all packings for visible damage.
2. Open every damaged box and inspect the contents for damage.
3. Immediately fill a claim form with the carrier if any fixture is damaged.
4. Store the fixture in its original packing in a protected area.



#### Note

If damage to any equipment is noted, file a claim form with the carrier immediately.



#### WARNING

Do not damage the cable insulation.



#### CAUTION

Do not unpack the fixture before it is at the installation site to avoid damage due to transportation and handling.

### 3.7 Store

Store the fixture in its original packing in a protected area. Indoor storage:

- Storage temperature: 14°F to 122°F (-10°C to +50°C).
- Humidity: <95% non condensing.

For long storage periods (longer than one year), we recommend to energize the LED lights once a year at nominal intensity (6.6 Amps) for 20 minutes.

### 3.8 Installation on L-868 Base

The light assembly is shipped complete, and is ready for installation.



To install the fixture on an L-868 base, see FAA AC 150/5345-30 and the project site-specific plans and specifications for details on L-868 base installation.

**Note** Mounting bolts are not supplied with the fixture. Mounting bolts and anti-rotation lock washers are normally supplied with the base can spacer or flange ring. If a flange ring is used, the bolt length is 1-1/4 inch (32mm) plus the thickness of the flange ring.

Also read the following guidelines:

1. Clean the base receptacle. Make sure the base receptacle is completely clean and dry. The mating surfaces must be clean and free of foreign particles.
2. If, present, fit an appropriate lifting tool into the two threaded holes, which are located 180° apart in the cover.



The lifting tool can be made from two 1/2 x 13 eyebolts (1-inch ID) and a 1/2-inch diameter, 16-inch (406mm) long rod or pipe inserted through the eyebolts.



**CAUTION**

Never hold the light fixture by the wires. Doing so may damage the insulation, break the waterproof seal and cause insulation faults and water leakage.

3. Carry the light assembly to the base.
4. Place the light assembly next to the opening in the L-868 base so that the L-823 connector can be connected with the mating receptacle from the L-830 or L-831 isolation transformer in the base. Make sure that the connection is solid and secure. Refer to the Electrical Supply section of the User manual for required isolation transformers.
5. Make sure items such as spacers, shims and gaskets are installed on the light base as indicated on site plans, specifications and drawings.
6. Position the light assembly over the L-868 base and set it onto the base. Align the light according to FAA AC 150/5345-30 and project plans and specifications. Remove the eyebolts and lifting rod.



**CAUTION**

Ensure that the cord set wires are NOT pinched between the base can and the fixture. Pinched wires can cause water to be drawn inside the fixture.

7. If present, lubricate the labyrinth gasket with water. soap may be added to the water (8" only).



**CAUTION**

Do not use silicon or any other type of grease. Avoid the use of soap that contains silicon or glycerin.

8. Attach the six fixing bolts and anti-vibration washers. [See FAA EB-83 (latest revision)]



**CAUTION**

Due to the risk of bolts vibrating loose, do not use any type of washer with the fixing bolts (such as split lock washers) other than an anti-vibration washer. Anti-vibration washers as defined in FAA EB-83 (latest revision).

9. Turn on the power to determine whether the LED fixture will illuminate. Operate for a minimum of five minutes.

### 3.9 Torquing and Installation Guidance for In-pavement Fixtures

In-pavement fixtures must be installed according to the plans and specifications; the applicable regulatory guidance; and the following guidance. The importance of using the proper fixture clamping components and bolt torque to minimize the risk for fixture failure or loosening of clamping components cannot be overemphasized. Refer to FAA Engineering Brief No 83 (latest revision) for torque and installation guidelines for this fixture.

Also see our Product Center at [www.adbsafegate.com](http://www.adbsafegate.com).

---



#### **CAUTION**

Read installation instructions in their entirety before starting installation.

- Failure to follow the installation guidance could result in bolt loosening or bolts breaking off, resulting in catastrophic failure of the fixture and/or the mounting system components.
  - Failure to follow these warnings may result in serious injury or equipment damage.
-

## 3.10 Shallow base can installation

Shallow base cans may be non-load bearing or load bearing depending on location or fixture application. Following are specific requirements to insure that an either an elevated or an in-pavement fixture is properly installed.



### CAUTION

Read installation instructions in their entirety before starting installation.

Fasteners:

- Make sure the power is OFF when you install or remove any fixture.
- Only use fasteners of the same type as the one originally supplied with the mounting support. See Base O-ring and Bolt Selection.
- Always tighten the fasteners to the recommended torque. Use a calibrated torque wrench and apply the recommended adhesive type.
- If this is not the case, this may cause the fasteners to loosen, damage the fixture, potentially to loosen the fixture. This can lead to a highly dangerous situation of FOD, with potential lethal consequences.
- Obey the instructions of the adhesives necessary for the fasteners.
- Only install the fixture on mounting supports:
  - That ADB Safegate has approved;
  - That are installed according to the Instruction Manual of the mounting support.
- Failure to do so can result in a highly dangerous situation of FOD, with potential lethal consequences.

Failure to follow these warnings may result in serious injury or equipment damage.



### CAUTION

Proper Operation:

- The fixture is supplied from a 6.6 A series circuit;
- The series circuit is powered by a Constant Current Regulator that complies with IEC 61822;
- The transformer is an AGL series transformer that complies with IEC 61823.
- The power of the series transformer shall not exceed 200 W, for versions with the monitoring option.
- The mounting support is correctly earthed. Failure to do so will void the warranty for all damages that occur as a result of voltage surges.
- Never hold the fixture by the cable leads. This can damage the insulation, break the waterproof seal and cause insulation faults and water leakage.



### Note

See the Instruction Manual of the mounting support for instructions on how to earth the mounting support.

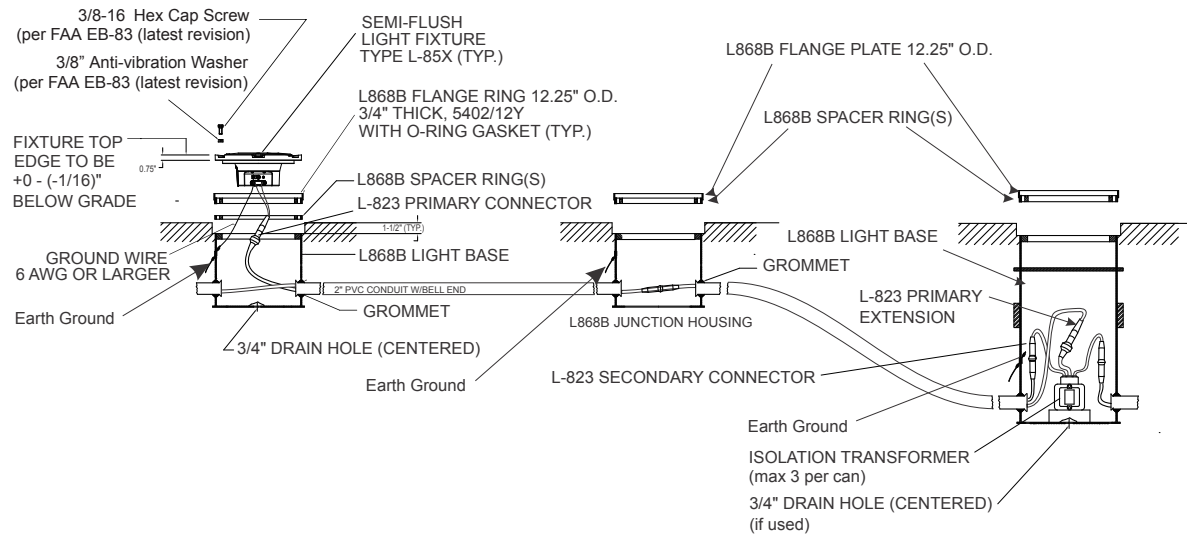
### 3.10.1 Installation on a Shallow Base

Installing the light fixture on a shallow base involves preparing the pavement recess and wireways, then installing the light fixture on a shallow base.

See FAA AC 150/5345-30 and the project site-specific plans and specifications for details on shallow base installation.

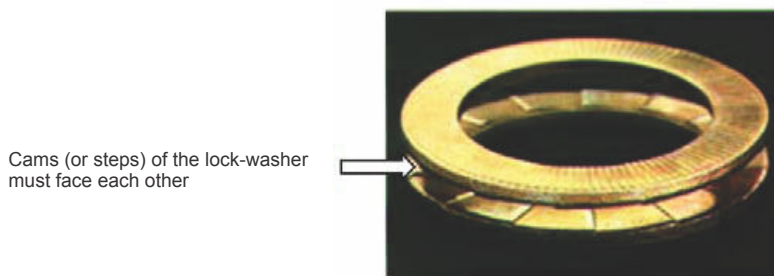
Also follow the applicable instructions in the previous section, when connecting, installing and powering the fixture.

**Figure 9: Example of a Shallow Base Installation**



1. Torque according to: FAA EB-83 (latest revision).

**Figure 10: Anti-vibration washer example**



**CAUTION**

Per FAA AC 150/5340-30, Chapter 10, and FAA Engineering Brief No 83 (latest revision), it is extremely important that other types of washers, such as split washers, must not be used. Failure to use properly installed anti-vibration lock washers will cause mounting bolts to become loose. The cams (or steps) of each half of the lock washer must face each other.

## 4.0 Maintenance

This section provides maintenance information and procedures for the L-852T F-Range light fixtures.

### 4.1 Maintenance Schedule

Service life depends upon the entire assembly being waterproof. All surfaces must be clean, dry and free of all foreign matter and all bolts must be properly tightened if the light fixture is to operate for extended periods without requiring maintenance.

To keep the F-Range light fixtures operating efficiently, follow a preventive maintenance schedule. Refer to [Table 4](#). Refer to FAA AC 150/5340-26 for more detailed information.

**Table 4: Range Light Fixture Maintenance**

Interval	Maintenance Task	Action
Daily	Check for burned-out lamp.	Replace lamp and film disc cutout, if used. Refer to <i>Replacing Lamp</i> in this section.
	Check for dim lamp.	Clean optical surface if dirty. Check for misalignment or presence of moisture in fixture.
Weekly	Check for dirty channel and lens.	Clean channel and prism. Refer to <i>Cleaning Light Channel and Lens</i> in this section.
Monthly (or more frequently during rainy seasons)	Check for moisture in the light fixture.	Open up the light fixture. Clean, dry, and inspect the light assembly. Replace O-ring.
Every 60 days, or whenever the light assembly is serviced	Check for improper torque on hold-down bolts.	Refer to "Appendix" for torque and installation guidelines for this fixture.
Semi-annually	Check for six inches (152 mm) of water in the L-868 base.	Pump water from base. Remove and inspect light for water damage. Refer to <i>Removing L-868 Base Water</i> in this section.
After snow removal	Check for damaged light fixtures.	Replace damaged fixtures. Use a power broom for snow removal, if practical.

### 4.2 Replacing Lamp



#### CAUTION

Read installation instructions in their entirety before starting installation.

- Turn off the circuit before replacing lamp(s). Failure to observe this warning may result in personal injury, death, or equipment damage.
- Allow time for the unit to cool. High interior temperatures may cause severe burns to personnel.

Failure to observe this warning may result in personal injury. Failure to follow these warnings may result in serious injury or equipment damage.

The preferred method of maintaining the F-Range inset light is to periodically and systematically replace the light assembly and return the replaced assembly to the maintenance shop for renovation. As an alternative, you can service the light assembly in the field. It is recommended, however, that field servicing be limited to cleaning lenses and replacing lamp(s).



#### Note

If any lamps are out, record the location of the fixture and replace the lamp when the circuit is turned off.

Refer to *Replacing Lamp* in the *Repair* section for lamp replacement procedure.

## 4.3 Maintenance Procedures

This subsection describes the following maintenance procedures:

1. "Replacing Lamp" on page 15
2. "Cleaning Lens" on page 15
3. "Checking Bolt Torque" on page 38
4. "Lifting Optical Unit Out of Base" on page 16

## 4.4 Cleaning Lens

To clean the lens, perform the following procedure:

1. Clean the outer surface of the lens using liquid glass cleaner. If the lens is coated with a substance impervious to the cleaner, apply a suitable solvent sparingly with a wad of cotton or a patch of cloth.
2. After the solvent has acted, remove the softened coating with a clean piece of cotton or cloth.
3. Dry the lens with gently, dry, oil-free compressed air at a pressure no greater than 10 psi (69 Knt/m2) to evaporate or remove all remaining cleaner.

## 4.5 Removing L-868 Base Water

---



### CAUTION

Read installation instructions in their entirety before starting installation.

1. Turn off the circuit when checking water level.
2. Cover the L-868 base with the appropriate steel cover plate after removing the light assembly.

Failure to follow these warnings may result in serious injury or equipment damage.

---

Check the water level in the L-868 base on a regular schedule. If more than six inches (152.4 mm) of water in the light base is found, pump the water from the base and remove and inspect the entire light assembly for water damage.

Water entering the L-868 base can become a serious problem, since freezing water can rupture the base.

## 4.6 Lifting Optical Unit Out of Base

To lift the optical unit from the light base, perform the following procedure:

1. Remove the six fixing screws and washers or self locking nuts.
  2. Fit the appropriate lifting tool into both holes located (180° apart) in the cover, lift the optical unit out of the base and place the optical unit next to the base.
  3. Disconnect the light fixture wires from the power wires coming from the transformer(s).
  4. Mount a serviced or new light fixture as described in *Installation on L-868 Base* in the *Installation* section.
- 



### Note

See "Installation Guidance for In-pavement Fixtures" on page 25.

---

5. Take the inset fixture unit back to the maintenance base where it can be serviced entirely.
- 



### CAUTION

Never hold the light fixture by the wires. This may damage the insulation, break the waterproof seal, and cause insulation faults and water leakage.

---







## 5.0 Troubleshooting

This section contains troubleshooting information. This information covers only the most common problems that you may encounter. If you cannot solve the problem with the information given here, contact your local ADB Safegate representative for help.

### 5.1 Troubleshooting Procedures

Troubleshooting procedures for the F-Range inset lights are contained here.

**Table 5: troubleshooting table**

Problem	Possible Cause	Corrective Action
1. Lamp not energizing	Defective lamp	Replace lamp and film disc cutout (if used). Refer to <i>Replacing Lamp</i> in the <i>Maintenance</i> section.
	Loose or broken contacts	Tighten or replace.
	Moisture inside assembly causing current leakage	Open up light assembly. Clean, dry, and inspect light assembly. Replace O-ring.
	Defective isolation transformer	Check transformer output current with meter.
2. Lamp not turning on at normal level	Continuity incorrect	Check lamp filament and wiring for continuity.
3. Lamp output distorted	Broken or damaged lens	Replace lens.
4. Improper color	Filter broken	Replace filter bracket assembly.
	Filter bracket broken	Replace filter bracket assembly.
5. Short lamp life	Current too high	Check constant current regulator and isolation transformer.
	Water in assembly	Inspect prism. Open light assembly. Clean, dry and inspect light assembly. Replace O-ring.
	Defective lamp	Replace lamp and film disc cutout (if used). Refer to <i>Replacing Lamp</i> in the <i>Maintenance</i> section. <b>NOTE:</b> Lamp interior will have a white powdery appearance if air has entered through a hole or crack.
	Overtoltage	Check to see if lamp has black burns. If so, check isolation transformer output with meter. Replace isolation transformer, if defective.
6. Distorted light beam output	Cracked or damaged lens	Replace lens.
7. Water inside optical chamber	Damaged or missing lens seals or top cover O-ring	Replace both lens seals. Replace top cover O-ring.

### 5.2 Repair

This section describes procedures for repairing and replacing parts.

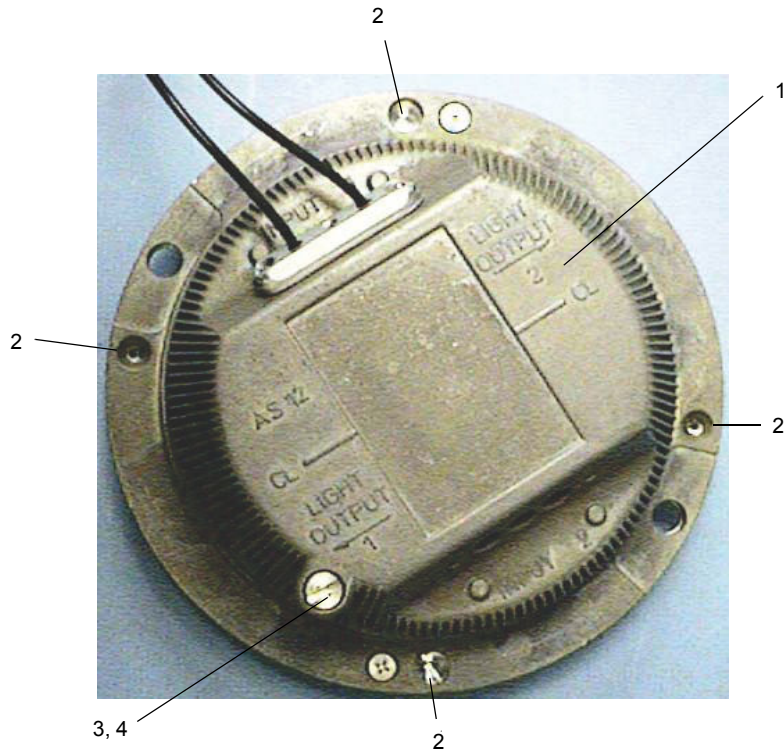
It includes opening the optical unit, and replacing the film disc cutout assembly, lamp and reflector holder assembly, lamp spring, lens, anti-rotation pins, and L-823 cordset. It also describes how to close the optical unit.

### 5.2.1 Opening Optical Unit

To open the optical unit, perform the following procedure:

1. Turn the light unit upside-down.
2. See [Figure 11](#). Remove the pressure release screw (3) and gasket O-ring (4).

**Figure 11: Pressure Release Screw**



1. Bottom Side of Inset Light (Inner Pan Assembly)

3. Pressure Release Screw

2. Four Phillips Pan Head Screws

4. O-Ring

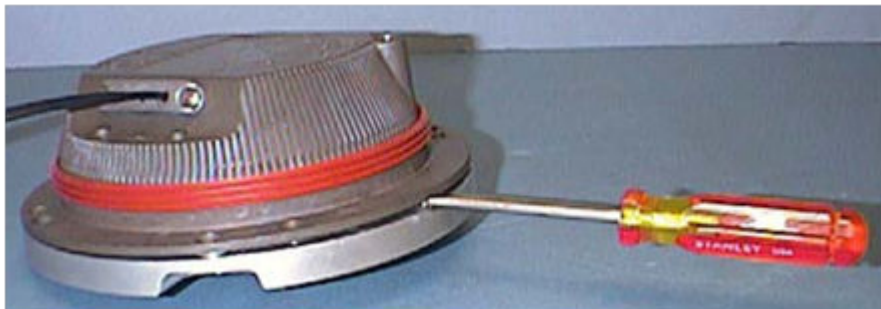
3. Remove the four Phillips pan head screws (2). The use of an impact driver may be required to unlock the screws.
4. See [Figure 12](#). Insert small or medium flat blade screwdriver in the machined recess slot between cover and inner pan assembly and turn it vertically to separate the inner cover from the cover.



#### Note

The two recess slots are 180 degrees apart.

**Figure 12: Separating Inner Pan Assembly from Top Cover**



### 5. Replacing Film Disc Cutout Assembly

Refer to [Table 6](#) for the parts referred to in Figure 9.

**Table 6: Parts List for Replacing Film Disc Cutout Assembly**

Item	Description	Part Number	Quantity	Note
1	Terminal block assembly		1	
	Terminal block assembly, with film disc cutout	44A6112-2		
	Terminal block assembly, without film disc cutout	44A6112-1		
2	Optional film disc cutout	47A0118	1	
3	Film disc cutout clip	4071.50.130	1	
4	Spring clip screw	7110.08.367	1	
5	Lamp reflector	4071.76.031	1	
6	Lamp		1	
	Lamp, 6.6 A/45 W PKX30d	2990.48.360		
	Lamp, 6.6 A/65 W PKX30d	2990.48.370		
7	Optical assembly	1411.22.100	1	A
8	Inner pan assembly		1	
	Inner pan assembly, with film disc cutout	44A4811-15		
	Inner pan assembly, without film disc cutout	44A4811-25		
9	Optional fast-on connectors	6111.87.140	2	
12	Spring, lamp	4071.50.581		

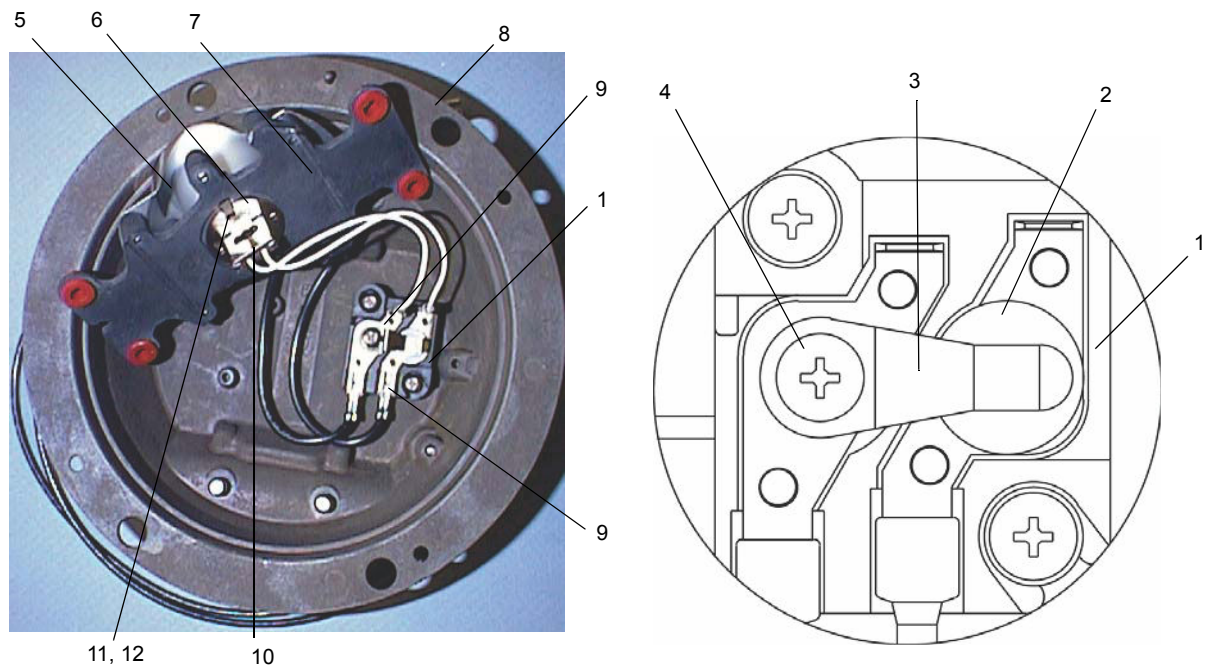
NOTE A: Refer to the *Optical Assembly Parts List* in the *Parts* section for all of the parts in the optical assembly.

6. To replace the film disc cutout assembly, perform the following procedure:

7. Open the optical unit. Refer to *Opening Optical Unit* in this section.

See [Figure 13](#). Disconnect the lamp (6) from the terminals on the terminal block (1).

**Figure 13: Film Disc Cutout Assembly and Optical Assembly**



1. Terminal Block	4. Spring Clip Screw	7. Optical Assembly	10. Bottom Lamp Notch (Semi-Circle)
2. Film Disc Cutout	5. Lamp Reflector	8. Inner Pan Assembly	11. Top Lamp Notch (Square)
3. Film Disc Cutout Clip	6. Lamp	9. Fast-On Connectors	12. Lamp Spring

8. Grasp the optical assembly (7) and pull straight up.
9. Using a Phillips head screwdriver, loosen or remove the spring clip screw (4).



### CAUTION

Make sure that the small button on the side of the film disc cutout is pointed up.

10. Remove installed film disc cutout (2) and replace with the new film disc cutout.
11. Reassemble all components in reverse order as removal. Inner cover assembly is now ready to reinstall on the top cover.

## 5.2.2 Replacing Lamp and Reflector Holder Assembly

Refer to Table 5 for the parts referred to in [Figure 13](#) and [Figure 6](#)

To replace the lamp and reflector holder assembly, perform the following procedure:

1. Open the optical unit. Refer to *Opening Optical Unit* in this section.
2. See [Figure 13](#). Lift the optical assembly (7) from the inner pan assembly (8).
3. See [Figure 6](#). Loosen the four screws (1) holding the lamp and reflector holder assembly (4).
4. Remove the lamp and reflector holder assembly and replace with new assembly.

## 5.2.3 Replacing Lamp



### CAUTION

Read installation instructions in their entirety before troubleshooting.

- Read and carefully follow the instructions throughout this manual for performing specific tasks and working with specific equipment.
- Follow all applicable safety procedures required by your company, industry standards and government or other regulatory agencies.
- De-energize the circuit and lock out the circuit or regulator so that the circuit cannot be energized by remote means before attempting to service the fixture.
- Allow time for the unit to cool. High interior temperatures may cause severe burns to personnel.

Failure to follow these warnings may result in serious injury or equipment damage.

Refer to [Table 7](#) for the parts referred to in [Figure 13](#) and [Figure 6](#).

**Table 7: Parts List for Replacing Lamp**

Item	Description	Part Number	Quantity	Note
Item 1 on Figure 6	Terminal block assembly		1	
	Terminal block assembly, with film disc cutout	44A6112-2		
	Terminal block assembly, without film disc cutout	44A6112-1		
Item 5 on Figure 2	Optical assembly grommets	4070.72.640	4	

**Table 7: Parts List for Replacing Lamp (continued)**

Item 6 on Figure 6	Lamp		1	
	Lamp, 6.6 A/45 W PKX30d	2990.48.360		
	Lamp, 6.6 A/65 W PKX30d	2990.48.370		
Item 7 on Figure 6	Optical assembly	1411.22.100	1	A
Item 8 on Figure 6	Inner pan assembly		1	
	Inner pan assembly, with film disc cutout	44A4811-15		
	Inner pan assembly, without film disc cutout	44A4811-25		
Item 9 on Figure 6	Optional fast-on connectors	6111.87.140	2	
Item 12 on Figure 6	Spring, lamp	4071.50.581	1	

NOTE A: Refer to the *Optical Assembly Parts List* in the *Parts* section for all of the parts in the optical assembly.

To replace the lamp, perform the following procedure:

1. Open the optical unit. Refer to *Opening Optical Unit* in this section.
2. See [Figure 13](#). Lift the optical assembly (7) from the inner pan assembly (8).
3. Unplug the lamp's fast-on connectors (9) from the terminal block (1).
4. Remove the lamp (6) from underneath the optical assembly by grasping the lamp with the thumb and pushing in against the lamp spring (12) and rocking the lamp out of the lamp socket.
5. To put in a new lamp, push the top lamp notch (11) into the lamp spring (12) and then push the bottom of the lamp under the bottom lamp notch (10).



**CAUTION**

Be careful not to break the lamp spring (12).

Never touch the bulb of the lamp with your bare hands. It will reduce the lifetime of the lamp considerably. Should it happen, clean the bulb with alcohol.

6. If a film disc cut-out is used, replace it with a new cutout. Refer to *Replacing Film Disc Cutout Assembly* in this section.
7. See [Figure 6](#). If the optical assembly grommets (5) are aged or damaged, replace them and then reinstall the optical assembly into the inner pan assembly.
8. Reinstall optical assembly. When plugging fast-on connectors to terminal blocks, make sure there is good contact between fast-on connectors and terminals.

**5.2.4 Replacing Lamp Spring**

Refer to [Table 8](#) for the parts referred to [Figure 13](#) and [Figure 6](#).

**Table 8: Parts List for Replacing Lamp Spring**

Item	Description	Part Number	Quantity	Note
Item 3 on Figure 2-6	Screws, panhead, M4 x 10, stainless steel cross recessed (lamp spring screw)	7110.08.367	5	
Item 6 on Figure 2-6	Spring, lamp	4071.50.581	1	
Item 7 on Figure 6-3	Optical assembly	1411.22.100	1	A

**Table 8: Parts List for Replacing Lamp Spring (continued)**

Item 8 on Figure 6-3	Inner pan assembly		1
	Inner pan assembly, with film disc cutout	44A4811-15	
	Inner pan assembly, without film disc cutout	44A4811-25	

NOTE A: Refer to the *Optical Assembly Parts List* in the *Parts* section for all of the parts in the optical assembly.

To replace the lamp spring, perform the following procedure:

1. Open the optical unit. Refer to *Opening Optical Unit* in this section.
2. See [Figure 13](#). Lift the optical assembly (7) from the inner pan assembly (8).
3. Remove the lamp and reflector holder assembly. Refer to *Replacing Lamp and Reflector Holder Assembly* in this section.
4. Remove the lamp. Refer to *Replacing Lamp* in this section.
5. See [Figure 6](#). Remove the lamp spring screw (3). The lamp spring (6) will fall out.
6. Put a new lamp spring in and tighten screw (3).
7. Reinstall lamp, lamp and reflector holder assembly, optical assembly, and optical unit.

### 5.2.5 Replacing Lens

Replace the lens if it is broken or its surface is badly pitted or scarred. Refer to [Table 9](#) for the parts referred to in [Figure 13](#) through [Figure 17](#).

**Table 9: Table 8: Parts List for Replacing Lens**

Item	Description	Part Number	Quantity	Note
Item 1 on Figure 6	Screws, M6 X 16	7100.08.562	8	
Item 1 on Figure 6	Lens gasket protection	4071.76.060	1	
Item 1 on Figure 6	Lens		1	
	Lens, blue	1428.00.430		
Item 2 on Figure 6	Washer, flat, M6	7283.05.053	8	
Item 2 on Figure 6	Lens cover	4071.76.020	1	
Item 3 on Figure 6	Lock washer, M6	7284.10.445	8	
Item 7 on Figure 6	Optical assembly	1411.22.100	1	A
Item 8 on Figure 6	Inner pan assembly		1	
	Inner pan assembly, with film disc cutout	44A4811-15		
	Inner pan assembly, without film disc cutout	44A4811-25		
Item 2 on Figure 6	Washer, flat, M6	7283.05.053	8	
Item 3 on Figure 6	Lock washer, M6	7284.10.445	8	

**Table 9: Table 8: Parts List for Replacing Lens (continued)**

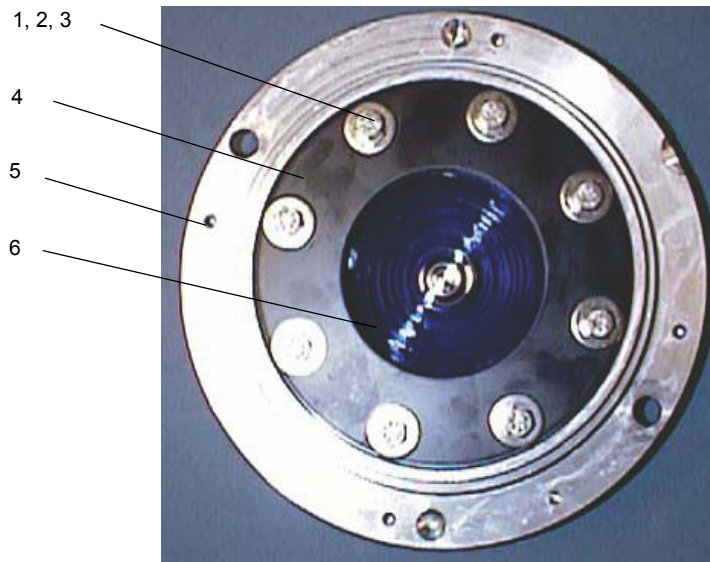
Item 4 on Figure 6	Lens support plate	4071.76.020	1
Item 3 on Figure 6	Lens gasket	4071.76.041	1

NOTE A: Refer to the *Optical Assembly Parts List* in the *Parts* section for all of the parts in the optical assembly.

To replace the lens, perform the following procedure:

1. Open the optical unit. Refer to *Opening Optical Unit* in this section.
2. See [Figure 13](#). Lift the optical assembly (7) from the inner pan assemble (8).
3. See [Figure 14](#). Unscrew the 8 screws (1) on the lens support plate (4). Remove the flat washers (2) and lock washers (3).

**Figure 14: Removing Lens Gasket Support Plate**

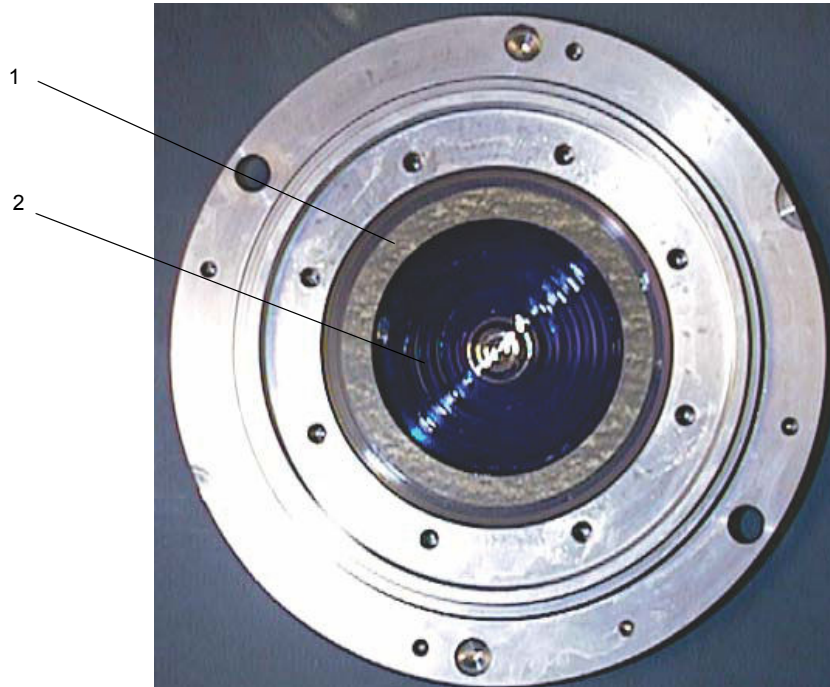


1. Screw	4. Lens Support Plate
2. Flat Washer	5. Inner Pan Assembly
3. Lock Washer	6. Lens

4. Remove the lens support plate (4).
5. See [Figure 15](#) Remove the lens gasket protection (1).

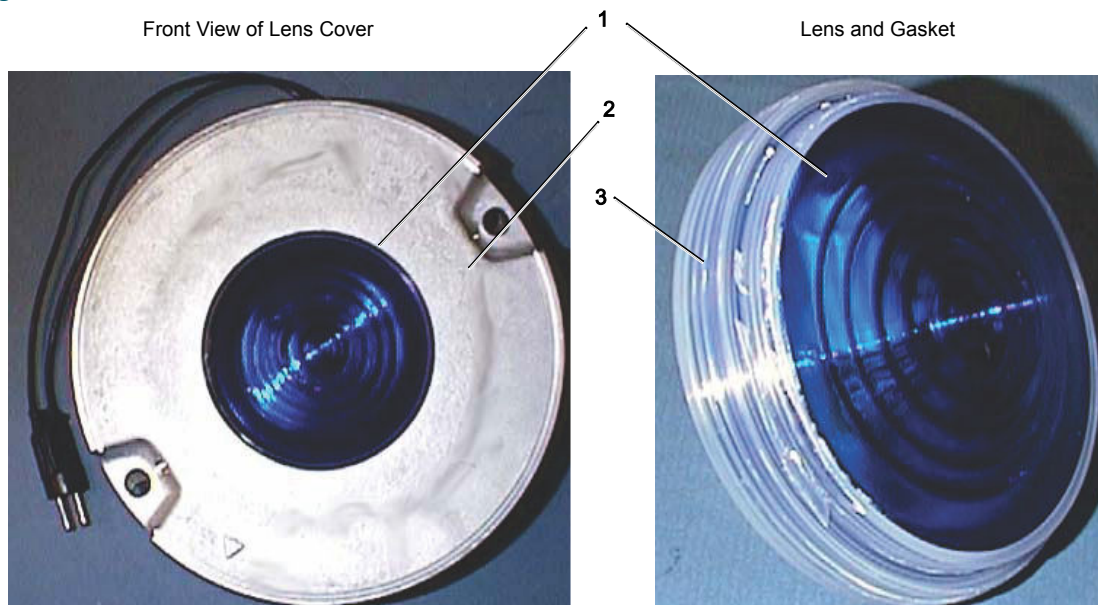


**Figure 15: Removing Lens Gasket Protection**



- a. Lens Gasket Protection
- b. Lens
- c. See [Figure 16](#) Turn the lens (1) on the front side and push the lens with the lens gasket (3) towards the inside of the lens cover (2).

**Figure 16: Front View of Lens and Gasket**



1. Lens

3. Top of Lens Gasket

2. Front Side of Lens Cover

6. Grasp the inner part of the top of the lens gasket (3) and pull the gasket off of the lens.





## CAUTION

Never use any abrasive substance. This will scratch or frost the lens.

7. Lens in the Maintenance section.
8. Apply a thin layer of lubricant MOLYKOTE BG87 INERTA or MOLYKOTE BG88 INERTA in the lens chamber using a small brush.
9. Install a new lens gasket (3) over the lens (1).



## Note

Replace lens gasket whenever you replace the lens.

10. See [Figure 14](#). Install the lens to the cover by means of the lens support plate (4) and the 8 screws (1). Be sure to include the washers (2) and lock washers (3).
11. See [Figure 11](#). Reinstall hardware with the Phillips pan head screws (2). Apply a droplet of sealant Loctite 270 to the last threads. Torque to 31 4 inch-pounds (3.5 ± 0.5 Nt-m).

### 5.2.6 Replacing L-823 Cordset

Refer to Table 9 for the parts referred to in [Figure 13](#) through [Figure 17](#)

Item	Description	Part Number	Quantity	Note
Item 1 on Figure 6-7	Screw, panhead, M4 x 10, (countersunk screws for cordset clamp)	7110.08.367	2	
Item 1 on Figure 6-3	Terminal block assembly		1	
	Terminal block assembly, with film disc cutout	44A6112-2		
	Terminal block assembly, without film disc cutout	44A6112-1		
Item 1 on Figure 6-8	L-823 cordset/cable assembly	1458.10.090	1	
Item 2 on Figure 6-7	Wire grommet	6126.01.031	2	
Item 3 on Figure 6-7	Cable clamp	4071.50.090	1	
Item 3 on Figure 6-8	Optional fast-on connectors	6111.87.140	2	
Item 7 on Figure 6-3	Optical assembly	1411.22.100	1	A
Item 8 on Figure 6-3	Inner pan assembly		1	
	Inner pan assembly, with film disc cutout	44A4811-15		
	Inner pan assembly, without film disc cutout	44A4811-25		

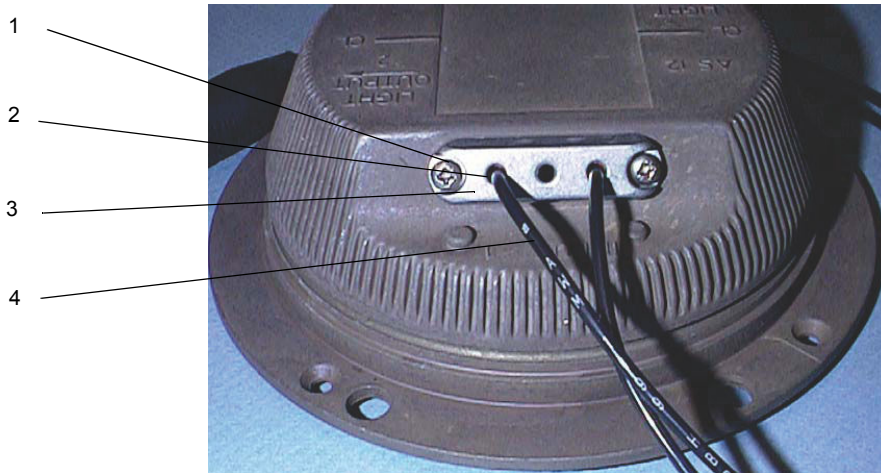
NOTE A: Refer to the *Optical Assembly Parts List* in the *Parts* section for all of the parts in the optical assembly.

To replace the L-823 cordset, perform the following procedure:

1. Open the optical unit. Refer to *Opening Optical Unit* in this section.
2. Remove the optical unit by performing the following procedure:
  - a) See [Figure 13](#). Lift up the optical assembly (7), manually, from the inner pan assembly (8).
  - b) Unplug the lamps fast-on connectors (9) from the terminal block (1).
3. See [Figure 17](#) Remove both screws (1) and the cable clamp (3).

**NOTE:** Replace the wire grommets (2) when damaged or aged.

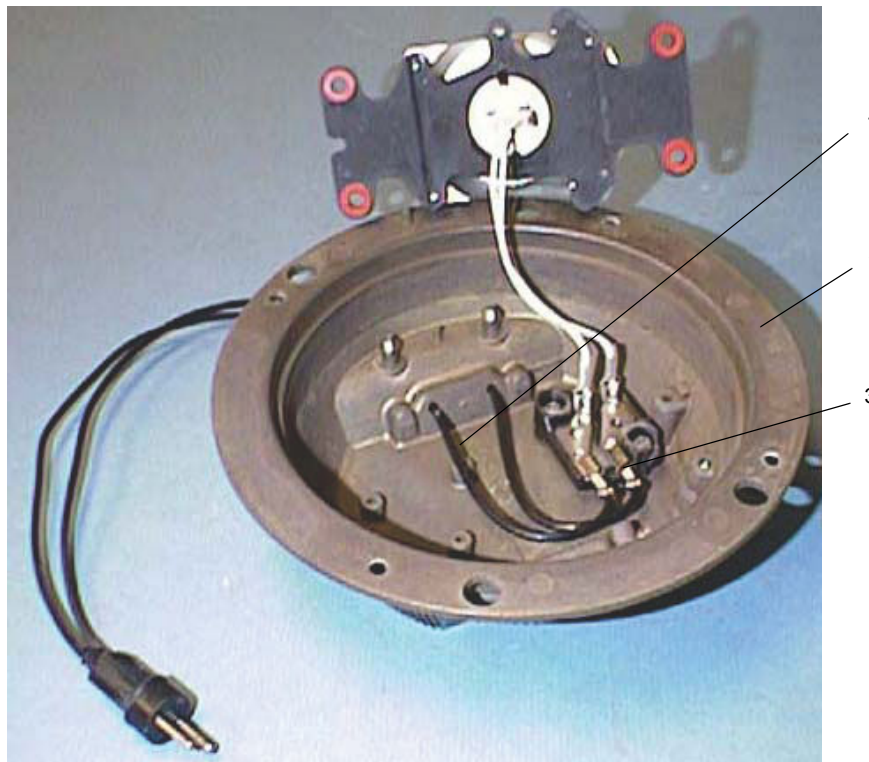
**Figure 17: Bottom View of Inset Light**



1. Screw	3. Cable Clamp
2. Wire Grommet	4. Cordset Assembly

4. See [Figure 18](#). Cut the fast-on connectors (3) from the cable assembly (1).

**Figure 18: Removing Fast-On Connectors and Cable Assembly**



1. Cable Assembly	3. Fast-On Connectors
2. Inner Cover	

5. See [Figure 17](#). Pull the cordset cable assembly (4) out of the inner cover and discard the wire grommets (2).
6. Bring the new cable assembly through the cable clamp.
7. Put a new wire grommet on each of the wires, taking care of the direction. Put the smaller diameter into the inner cover recesses.
8. Install the wires in the inner pan assembly.

9. Reinstall the cable clamp by means of both cross recessed countersunk screws (1).



**CAUTION**

Do not torque down the screws entirely at this step.

10. Remove the insulation of the wires over about 5 mm.

11. Crimp on the new fast-on connectors and connect them to the terminals. Adjust the wires inside the inner cover.

12. Torque the screws (1) to 31 ± 4 inch-pounds (3.5 ± 0.5 Nt-m).

**5.2.7 Replacing Anti- Rotation Pins**

Refer to Table 10 for the parts referred to in [Figure 19](#).

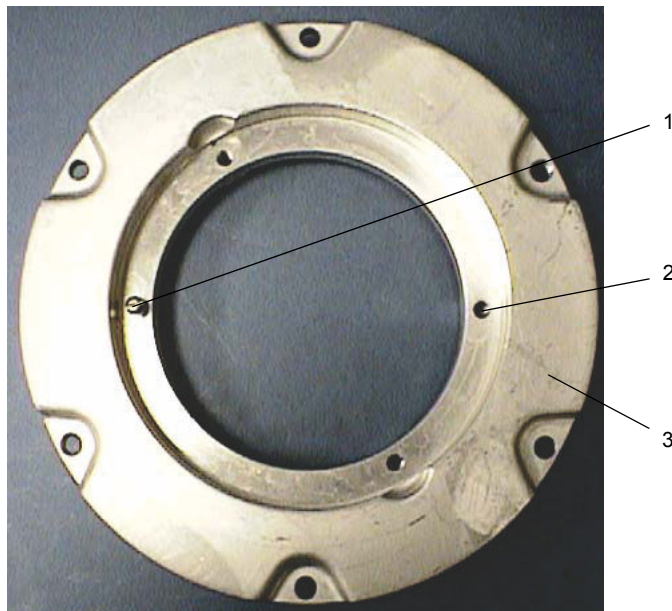
Item	Description	Part Number	Quantity	Note
1	Anti-rotation pin	4071.50.120	1	
2	Adapter ring	62D0690	1	

To replace the anti-rotation pins on the adapter ring, perform the following procedure:

1. See [Figure 19](#)

Use a medium-size flat blade screwdriver to unscrew the anti-rotation pin (1).

**Figure 19: Anti-Rotation Pins**



**Table 10: Parts List for Replacing Anti-Rotation Pin**

1.	Anti-Rotation Pin	2.	Hole for Anti-Rotation Pin	3.	Adapter Ring
----	-------------------	----	----------------------------	----	--------------

2. Clean pin threads.

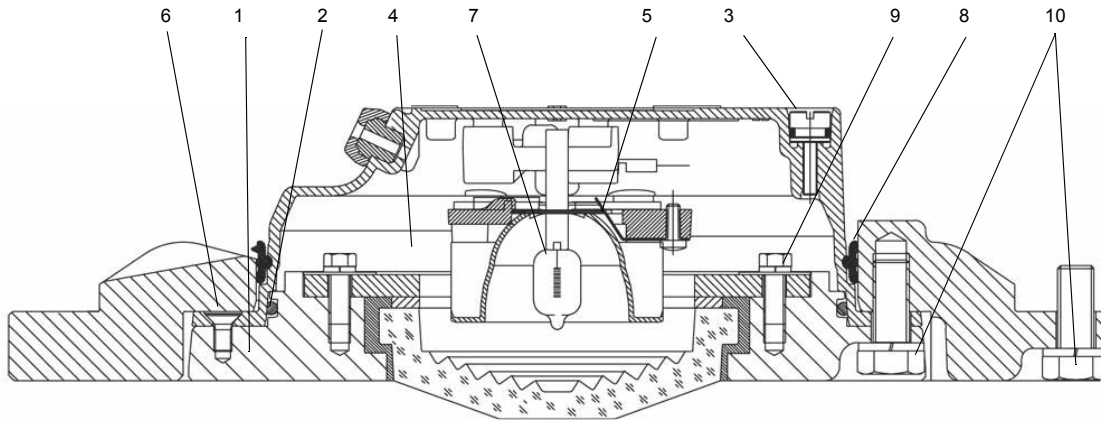
3. Replace with a new pin.

4. Use a drop of Grade AV Loctite on pin threads. Torque to 31 ±5 inch-pounds .

## 5.2.8 Closing Optical Unit

1. See Figure 20. Turn the top cover (1) upside down.

**Figure 20: Upside Down View of L-852T Light Fixture (8-inch Adapter Ring version)**



1. Top Cover	4. Inner Cover	7. Lamp	10. Mounting Hex Head Cap Screw
2. O-Ring	5. Lamp and Reflector Holder Assembly	8. Adapter Ring Seal	
3. Pressure Release Screw	6. Countersunk Screws	9. Lens Plate Hex Head Cap Screw	

2. Make sure that the contact surfaces with the O-ring (2) are clean and apply a light coat of high quality neutral silicone grease.
3. Install a new greased O-ring (2) in the groove located in the top cover.



### Note

Use a synthetic grease such as MOLYKOTE BG87 INERTA or MOLYKOTE BG88 INERTA.

4. If necessary, remove the pressure release screw (3).
5. Install the inner cover (4) on top of the cover (1).
6. Make sure the lamp holder (5) and lamp (7) are correctly positioned and that the wires of the lamps do not get damaged between both parts (cover and inner cover).

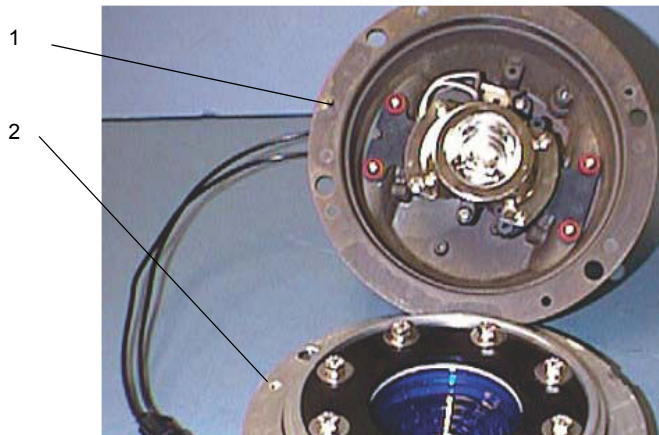


### CAUTION

Make sure that when you place the inner cover on the top cover, the index pin hole on the top cover (1) is aligned with the index pin hole on the inner cover (2). Not aligning the F-Range inset light by the index pin could crack the inner pan and cross-thread the countersunk screws.

7. See [Figure 21](#). Align the index pin (1) on the inner cover with the index pin hole on the top cover (2).

**Figure 21: Aligning Index Pins**



8. See [Figure 20](#) Press the inner cover on the top cover and secure with the countersunk screws (6). Apply a droplet of Loctite 222 to the last threads. Torque screws to  $22 \pm 4$  inch-pounds ( $2.5 \pm 0.5$  N-m).

9. Check the water tightness of the assembly by replacing the pressure release screw with a pressure test fixture. The leak path can then be located by submerging the assembly in a tank of water while pressurizing using shop air pressure to a maximum of 20 psi.

10. Reinstall the pressure release screw (3).

11. Press the optical assembly back into the adapter ring. If there is a gasket around the inner cover pan, apply a small amount of grease, such as MOLYKOTE BG87 INERTA or MOLYKOTE BG88 INERTA to improve pressing optical assembly into the adapter ring. Be sure to align the two blind holes on the bottom of the optical assembly with the two anti-rotation pins in the adapter ring before pressing the optical assembly into the adapter ring.

12. See “L-867 base can installation (non-load bearing)” on page 31.

### 5.2.9 Testing for Leaks

To test for leaks, perform the following procedure:

1. See [Figure 22](#).

Remove pressure relief screw.

2. See [Figure 23](#).

Screw pressure test fitting into the pressure relief port (the opening created when the pressure relief screw is removed).  
Screw fitting hand-tight.

**Figure 22: Pressure Relief Screw**







## 5.3 Material Handling Precautions: Fasteners



### DANGER

#### Foreign Object Damage - FOD

This equipment may contain fasteners that may come loose - torque properly.

- Only use fasteners of the same type as the one originally supplied with the equipment.
- Use of incorrect combination of gaskets, bolts and nuts can create severe damages to the product installation and create safety risk .
- You need to know what base the light fixture will be installed in, in order to chose the correct gasket, bolts and nuts.
- Bolt type, length, and torque value are determined by type of base, height of spacers used, and clamp force required in FAA Engineering Brief No 83 (latest revision).
- Due to the risk of bolts vibrating loose, do not use any type of washer with the fixing bolts (such as split lock washers) other than an anti-vibration washer. Anti-vibration washers as defined in FAA EB 83 (latest edition) must be used. For installations other than FAA, use the base can manufacturer's recommendations.
- Always tighten the fasteners to the recommended torque. Use a calibrated torque wrench and apply the recommended adhesive type.
- Obey the instructions of the adhesives necessary for the fasteners.

**Failure to follow these warnings may cause the fasteners to loosen, damage the equipment, potentially to loosen the equipment. This can lead to a highly dangerous situation of FOD, with potential lethal consequences.**



### Note

To minimize the risk of errors, the ADB SAFEGATE Sales Representative will have information on which gasket goes with which base. This information is also provided in the product Data sheets, the User Manuals and the Spare Part Lists.



### CAUTION

Use of incorrect combination of gaskets, bolts and nuts can create severe damages to the product installation and create multiple safety risks.

To obtain a safe and watertight installation the O-ring and retaining bolt stated in the document must be used.

You need to know what base the light fixture will be installed in, in order to choose the correct gasket, bolts and nuts.

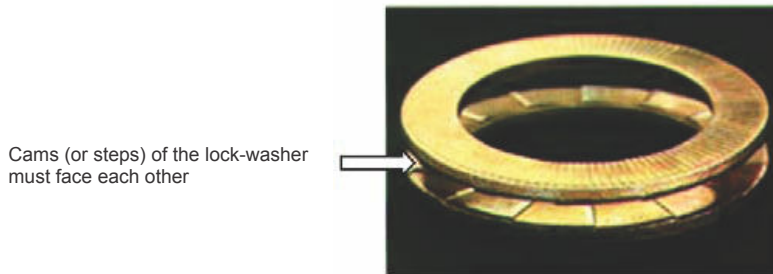
**Failure to follow these cautions can result in equipment damage or aircraft FOD.**

## 5.4 Bolt Torque Preventive Maintenance Schedule

An established schedule for checking light fixture bolt torque and bolt condition is mandatory. This is particularly true for areas that are subject to high impact loads from aircraft such as runway status lights, runway touchdown zone lights, runway centerline lights, and taxiway lead-off lights. Although AC 150/5340-26 offers a recommended schedule for periodic checks, these checks should be tailored to the facility based on local conditions such as environmental issues and runway traffic load.

1. Torque according to: FAA Engineering Brief No 83 (latest revision).

**Figure 24: Anti-vibration washer example**



### CAUTION

Per FAA AC 150/5340-30, Chapter 10, and FAA Engineering Brief No 83 (latest revision), it is extremely important that other types of washers, such as split washers, must not be used. Failure to use properly installed anti-vibration lock washers will cause mounting bolts to become loose. The cams (or steps) of each half of the lock washer must face each other.

---

FAA Cert Alert No. 14-03 refers to AC 150/5340-26 for the frequency of checking bolt torque. AC 150/5340-26 (latest revision) paragraph 5.3.4.1.4, *Bi-Monthly Checks* states: "The torque of the bolts attaching the light fixture to its base should be checked with a calibrated torque wrench – never use an impact wrench."

Regular inspection as outlined in FAA Engineering Brief 83 (latest edition), Canada Civil Aviation Safety Alert Document CASA 2014-05, and any other applicable regulatory guidelines is critical in insuring torque on all bolts is restored to optimum values. Bolts that loosen more often should be inspected and re-torqued on a more frequent basis.

It is especially important to maintain a regular inspection schedule for LED fixtures. Since LED fixtures operate more reliably and are not subject to removal/replacement/re-torque as frequently as would be seen with incandescent fixtures, it is even more important to implement regular torque inspections.

It is critical that remedial action be taken if bolts are found to be loose or missing during inspection. If this occurs, it is important to carefully inspect all structural elements of the mounting system as defined in Installation. Also inspect the base can for general structural conditions such as:

- Is the base can solidly mounted in the pavement, and not moving or rocking during rollovers?
- If a base can extension is present, are all extension attachment bolts tight?

If poor base can structure or mounting system components are not in accordance with regulatory requirements or are in poor condition, it is the airport's responsibility to:

- Increase the frequency of bolt torque inspection to insure that no bolts become loose or missing.
- Quickly replace/repair the mounting system components, which may include replacing the entire base can.

Airport operators must also ensure these maintenance activities are properly documented.

### Digital Asset Tracking and Service Application Information

ALIS is ADB SAFEGATE's new digital asset tracking, inspection and service solution, helps airports easily register airside assets, electronically schedule and track maintenance, and record maintenance and inspection tasks in compliance with ICAO and FAA standards.



---

Easy to implement and use, cloud-based software enables a more reliable and fail-safe approach to asset tracking and maintenance by always using live field data and eliminating inefficiencies caused by human error. Every asset is registered using GPS data and its status recorded, so airport maintenance teams get a clearer view of maintenance schedules and history, allowing them to manage resources more effectively as well as improve the safety and longevity of airside assets. This increased visibility helps airports plan and schedule preventive maintenance, or undertake corrective maintenance more quickly, to reduce downtime and significantly improve operational availability.

<https://adbsafegate.com/product-center/airfield/airside-services/ALIS-airside-maintenance>

- Easily integrates electronic torque measurements and photometric measurement reports to provide a complete view of the asset's status.
- ALIS can be integrated with the AirTorque or Ingersoll Rand® QX series wrenches, which are used for accurate, ergonomic torque inspections of AGL fixtures. The applied torque can seamlessly be registered in the ALIS system as a part of the maintenance record.
- The iPhone application of ALIS – ALIS Personal – makes it easier than ever to register maintenance actions while working. It will proactively show you which assets you still need to work on and select the closest one to you automatically. ALIS Personal acts as a feedback and information device for the associated torque wrench.



## 6.0 Parts

### Ordering Code

44A6099 - X X X

#### Lamp/Lens

- 1 = 45 W/6.6 A Blue
- 2 = 45 W/6.6 A Red<sup>1</sup>
- 3 = 45 W/6.6 A Yellow<sup>1,2</sup>
- 5 = 45 W/6.6 A Green<sup>1,2</sup>

#### Film Disc Cutout

- 1 = Included
- 2 = Not Included

#### Mounting

- 1 = 8-inch fixture with adapter ring for mounting on a standard L-868B light base
- 2 = 12-inch fixture for mounting on a standard L-868B light base
- 3 = 12-inch fixture for mounting on a standard L-867B light base

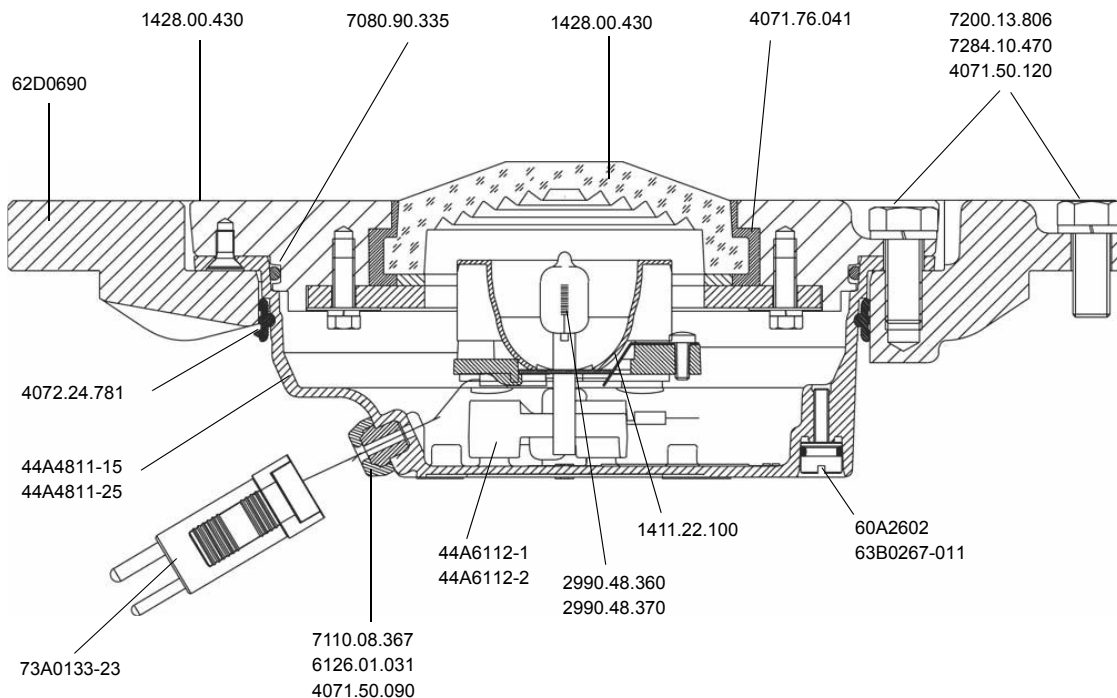
#### Notes

- <sup>1</sup> Color not recognized by FAA
- <sup>2</sup> For helipad applications

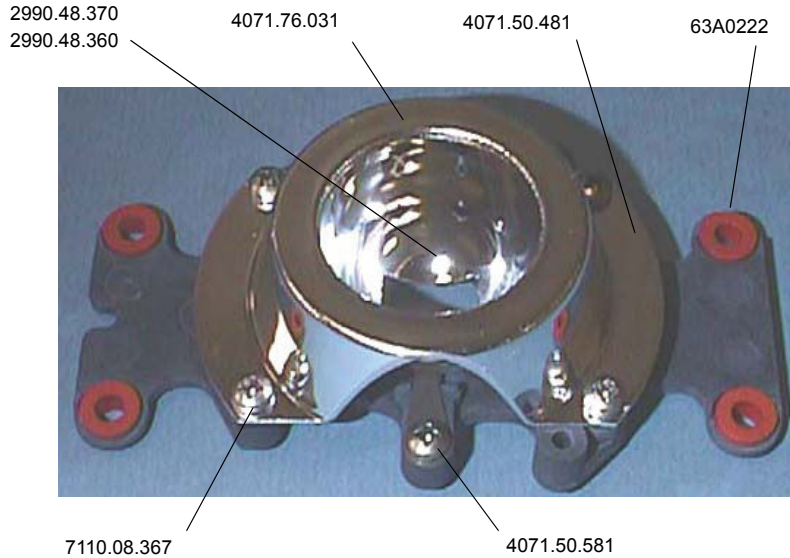
## 6.1 Parts Diagrams

To order parts, call ADB SAFEGATE Customer Service or your local representative. Use this four-column parts list, and the accompanying illustration, to describe and locate parts correctly.

**Figure 25: F-Range L-852T Light Fixture**



### 6.1.1 F-Range Optical Assembly Parts List



## 6.2 Spare Parts

Create a sufficiently large stock of spare parts to maintain the unit and the fixtures in the field. Consider acquiring approximately 10% spare final assemblies (with a minimum quantity of 1) for the total amount of equipment in the field. This allows for repairs to be made in the shop. Components that are more likely to need replacement, such as prisms, prism gaskets and PCB subassemblies should be stocked in smaller quantities. For the unit, it is highly recommended to have a least one entire unit as a spare, or for larger installations, at least 10% of the total units installed.

See individual product manuals for recommended fixture spares. For the unit, see the table below for spares.

- Consider acquiring 10% spares for critical components noted as (A) in the table below. If only a small number of units are installed, consider acquiring at least 1 of each of the components noted as (A) below.
- Also consider acquiring 1% spares for parts noted as (B) in the table below. If it is important to have a robust level of spare parts on hand, and only a small number of units are installed, consider acquiring 1 of each of the components noted as (B) below.

**Table 11: Spare Parts**

Part Number	Description	Location	Note	Spares
44A4811-15	Inner pan assembly, with film disc cutout			B
44A4811-25	Inner pan assembly, without film disc cutout			B
44A6112-1	Terminal block assembly, without film disc cutout			A
44A6112-2	Terminal block assembly, with film disc cutout			A
2990.48.360	Lamp, 6.6 A/45 W PKX30d			A
60A2602	Pressure release screw			B
62D0690	Adapting ring, 8-12 in.			B
1428.00.430	Cover assembly, blue lens			A
1411.22.100	Optical assembly		A	A
73A0133-23	L-823 cordset			A
2990.48.370	Lamp, 6.6 A/65 W PKX30d			A
4071.50.090	Cable clamp (for cordset)			B

**Table 11: Spare Parts (continued)**

4071.50.120	Stud, 3/8 in., UNC (anti-rotation pin)	B	A
4072.24.781	Gasket, external		A
4071.76.041	Gasket, lens		A
6126.01.031	Cable clamp gasket		A
63B0267-011	Gasket, O-ring, Viton		A
63A1285	Seal, O-ring		A
64A0964-10	Screw, panhead, M4 x 10, stainless steel cross recess		A
7200.13.806	Screw, 3/8-16 in. UNC x 7/8 in.		A
7284.10.470	Washer, spring, M10		A

NOTE A: Refer to *Optical Assembly Parts List* in this section for optical assembly parts and part numbers.

NOTE B: Anti-rotation pins can be removed and replaced. Refer to *Replacing Anti-Rotation Pins* in the *Repair* section.



## Appendix A: SUPPORT

Our experienced engineers are available for support and service at all times, 24 hour/7 days a week. They are part of a dynamic organization making sure the entire ADB SAFEGATE is committed to minimal disturbance for airport operations.

### ADB SAFEGATE Support

#### Live Technical Support - Americas

If at any time you have a question or concern about your product, just contact ADB SAFEGATE's technical service department. Trained in all areas of system issues, troubleshooting, quality control and technical assistance, our highly experienced Technical support specialists are available 24 hours a day, seven days a week to provide assistance over the phone.

ADB SAFEGATE **Americas Technical Service & Support (US & Canada): +1-800-545-4157**

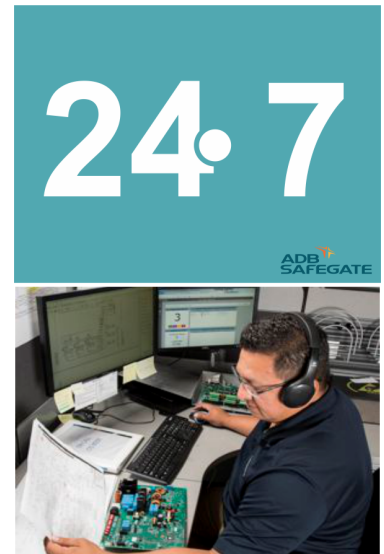
**ADB SAFEGATE Americas Technical Service & Support (International): +1-614-861-1304**

During regular business hours, you can also Chat with a Service Technician. We look forward to working with you!

#### Before You Call

When you have an airfield lighting or system control system problem it is our goal to support airfield maintenance staff as quickly as possible. To support this effort we ask that you have the following information ready before calling.

- The *airport code*
- If not with an airport, then company name (prefer customer id number)
- Contact phone number and email address
- Product with part number preferable or product number
- Have you reviewed the product's manual and troubleshooting guide
- Do you have a *True RMS* meter available (and any other necessary tools)
- Be located with the product ready to troubleshoot



#### Note

For more information, see [www.adbsafegate.com](http://www.adbsafegate.com), or contact ADB SAFEGATE Support via email at [support@adbsafegate.com](mailto:support@adbsafegate.com) or

Brussels: +32 2 722 17 11

Rest of Europe: +46 (0) 40 699 17 40

Americas: +1 614 861 1304. Press 3 for technical service or press 4 for sales support.

China: +86 (10) 8476 0106

### A.1 ADB SAFEGATE Website

The ADB SAFEGATE website, [www.adbsafegate.com](http://www.adbsafegate.com), offers information regarding our airport solutions, products, company, news, links, downloads, references, contacts and more.

## A.2 Recycling

### A.2.1 Local Authority Recycling

The disposal of ADB SAFEGATE products is to be made at an applicable collection point for the recycling of electrical and electronic equipment. The correct disposal of equipment prevents any potential negative consequences for the environment and human health, which could otherwise be caused by inappropriate waste handling. The recycling of materials helps to conserve natural resources. For more detailed information about recycling of products, contact your local authority city office.

### A.2.2 ADB SAFEGATE Recycling

ADB SAFEGATE is fully committed to environmentally-conscious manufacturing with strict monitoring of our own processes as well as supplier components and sub-contractor operations. ADB SAFEGATE offers a recycling program for our products to all customers worldwide, whether or not the products were sold within the EU.

ADB SAFEGATE products and/or specific electrical and electronic component parts which are fully removed/separated from any customer equipment and returned will be accepted for our recycling program.

All items returned must be clearly labeled as follows:

- For *ROHS/WEEE* Recycling
- Sender contact information (Name, Business Address, Phone number).
- Main Unit Serial Number.

ADB SAFEGATE will continue to monitor and update according for any future requirements for *EU directives* as and when *EU member states* implement new *regulations* and or *amendments*. It is our aim to maintain our *compliance plan* and assist our customers.



## Company Addresses

ADB SAFEGATE	ADB SAFEGATE, Belgium: Leuvensesteenweg 585, B-1930 Zaventem Belgium
Contact: Tel.: +32 2 722 17 11, Fax: +32 2 722 17 64	Email: <a href="mailto:marketing@adbsafegate.com">marketing@adbsafegate.com</a> Internet: <a href="http://www.adbsafegate.com">www.adbsafegate.com</a>
Americas LLC	ADB SAFEGATE, Americas: 977 Gahanna Parkway, Columbus, OH 43230 USA
Contact: Tel.: +1 (614) 861 1304, Fax: +1 (614) 864 2069	Email: <a href="mailto:sales.us@adbsafegate.com">sales.us@adbsafegate.com</a> Internet: <a href="http://www.adbsafegate.com">www.adbsafegate.com</a>
ADB SAFEGATE Sweden AB	ADB SAFEGATE, Sweden: Djurhagegatan 19 SE-213 76 Malmö Sweden
Contact: Tel.: +46 (0)40 699 17 00, Fax: +46 (0)40 699 17 30	Email: <a href="mailto:marketing@adbsafegate.com">marketing@adbsafegate.com</a> Internet: <a href="http://www.adbsafegate.com">www.adbsafegate.com</a>
ADB SAFEGATE Airfield Technologies Ltd. China	ADB SAFEGATE, China: Unit 603, D Block, CAMIC International Convention Center, No 3, Hua Jia Di East road, ChaoYang district, Beijing 100102 P.R. China
Contact: Tel.: +86 (10) 8476 0106, Fax: +86 (10) 8476 0090	Email: <a href="mailto:china@safegate.com">china@safegate.com</a> Internet: <a href="http://www.adbsafegate.com">www.adbsafegate.com</a>
ADB SAFEGATE Germany GmbH	ADB SAFEGATE Germany GmbH, Mannheim: Konrad-Zuse-Ring 6, D-68163 Mannheim Germany
Contact: Tel.: +49 (621) 87 55 76-0, Fax: +49 (621) 87 55 76-55	Email: <a href="mailto:marketing@adbsafegate.com">marketing@adbsafegate.com</a> Internet: <a href="http://www.adbsafegate.com">www.adbsafegate.com</a>



## Powering Your Airport Performance from Approach to Departure

[adbsafegate.com](https://adbsafegate.com)

Copyright © ADB SAFEGATE, all rights reserved

