

RELIANCE

Approach Flash System
Elevated and inset



Compliance with Standards (current Versions)

FAA	EB 67D
ICAO	Annex 14, Vol. I
IEC	TS 61827
NATO	STANAG 3316

Uses

LED light used for approach sequential flash and threshold identification for CAT I, II and III operations

Features and Benefits

- Dynamic system configuration by parameter setting
- Single light monitoring even in standby mode
- Dynamic operation mode in 3 brightness steps (100%, 10% and 3%)
- Flash frequency switchable between 2 or 1 Hz

- Optional lights with high intensity
- Service local control at control unit possible
- Comfort control panel for service local control
- lucDMC Service Software
- Over voltage and lighting current protection of power and data lines
- 1x parallel remote control interface (default)
- 2x serial remote control interface (redundant) with RS-485 MODBUS / RTU (optional)
- Optional remote control interface with Ethernet MODBUS/TCP or PROFIBUS DP (optional)
- Optional CANBUS interface (proprietary protocol for RELIANCE control system)
- Light power supply with SELV
- EMI (Electro-Magnetic Interference) filter to harmonize power fluctuation

System Design

The RELIANCE™ Approach Flash System, referred to as SFL, consists of a control unit, main chain (SFL - light 1..30), threshold identification (TIL - light 31..32) and power distribution units (1..32).

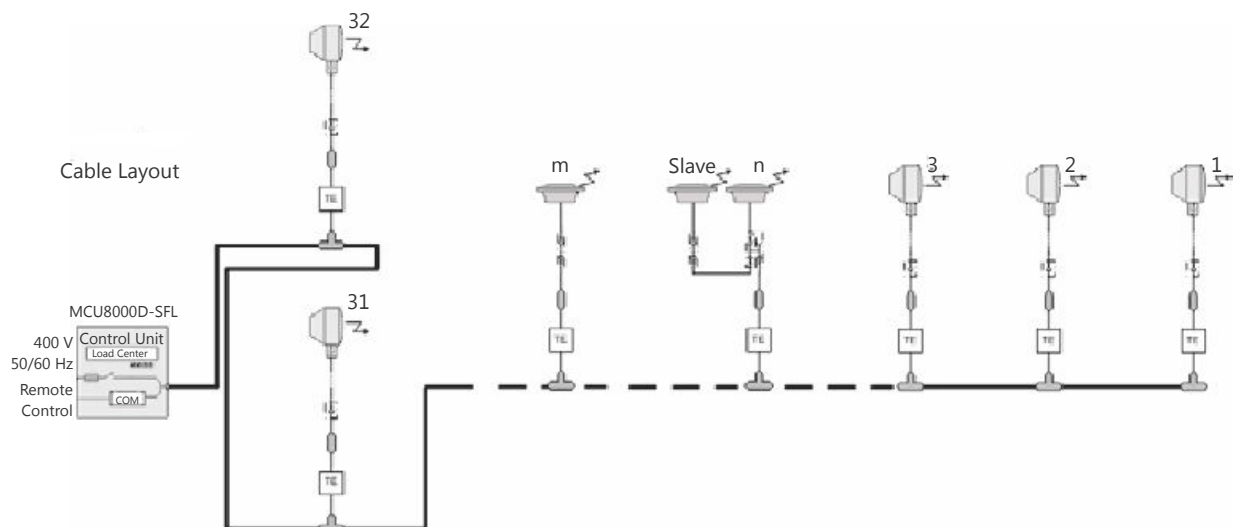

RELIANCE

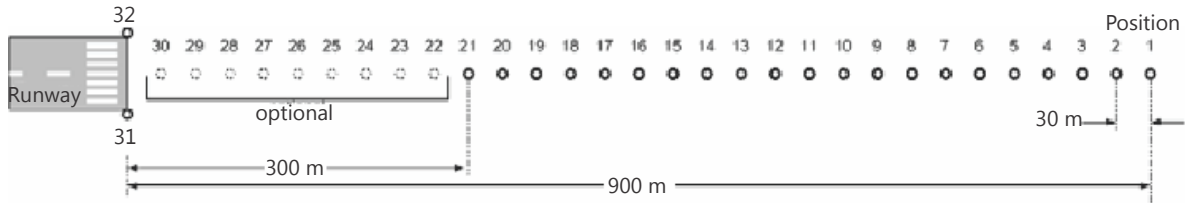

The RELIANCE SFL system enables following static (installation) or dynamic (configuration settings) system configurations:

- Full main chain with/without TIL (light 1..32)
- Reduced main chain with/without TIL (light 1..20 + 31..32)
- TIL without main chain (light 31..32)

Elevated, single inset or double inset lights available for installation.

Principle terminal diagram of the system

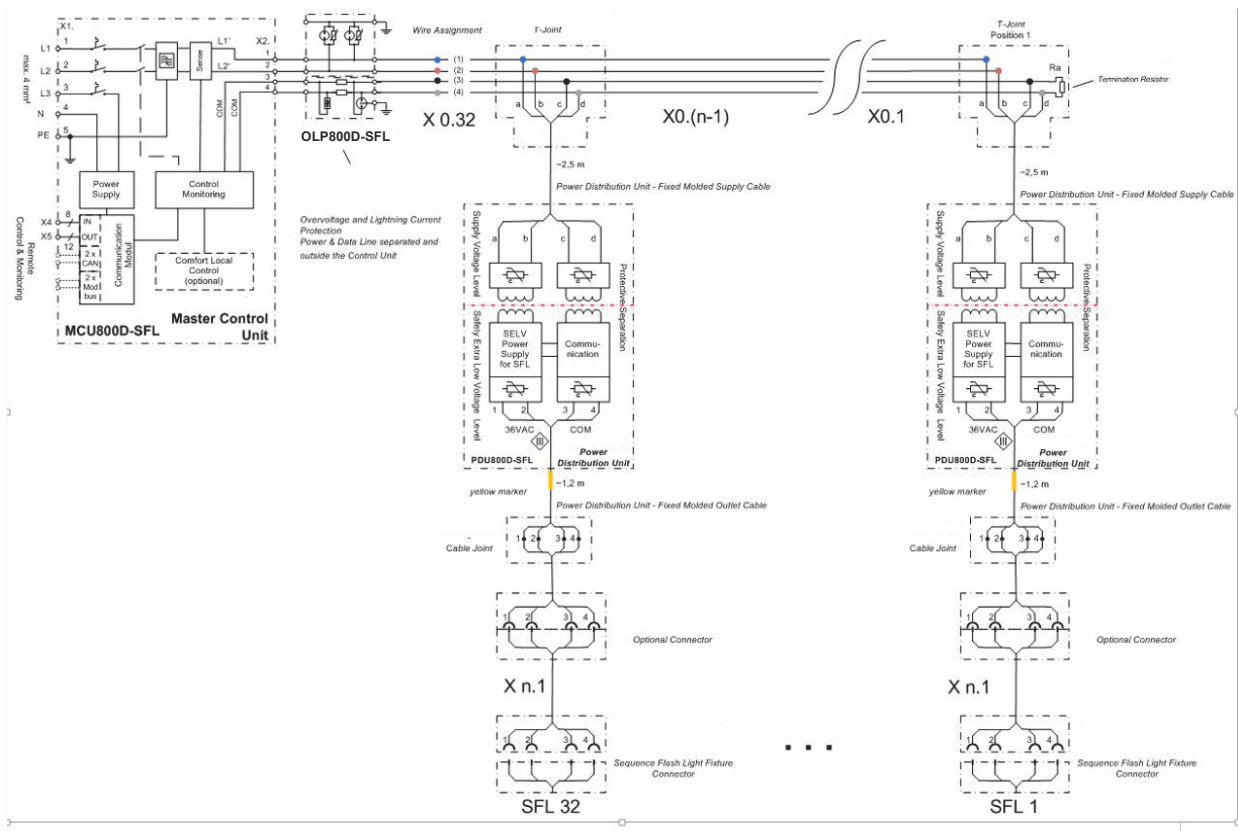

Technical Data

Control Unit (MCU800D-SFL)	
Power supply:	Power circuit: 400 VAC, 3 Ph., 50/60 Hz
Power consumption:	~ 1,4 kVA, asymmetric load, main load at L1/L2
Fuse:	Internal fuse automat 10A fuse characteristic K
Communication interface remote control:	1x parallel remote control interface (default) 2x serial remote control interface (redundant) with RS-485 MODBUS / RTU (optional) Optional remote control interface with Ethernet MODBUS/TCP or PROFIBUS DP (optional) Optional CANBUS interface (proprietary protocol for RELIANCE control system)
Communication interface comfort local control:	I2C
Communication interface service computer:	USB
Communication interface flash lights:	2-wire power line
Environmental temperature:	-25 to +45 °C
Relative humidity, not condensed:	10 to 90%
International Protection class:	IP 43
Altitude over NN (operation):	-100 to +2.500 m
Housing:	Metal housing wall mounted
Dimensions (B × H × D):	600 × 600 × 210 mm
Weight:	~ 22 kg

Power Distribution Unit (PDU800D-SFL)	
Power circuit:	Primary circuit: 400 VAC, 50/60 Hz Primary circuit: 36 VAC (SELV)
Power supply:	Control voltage 24 V from the cabinet
Data communication:	Primary circuit: Powerline Primary circuit: Powerline (SELV)
Environmental temperature:	-40 to +55 °C
Relative humidity, not condensed:	10 to 100%
International Protection class:	IP 68, 1 m immersion depth
Altitude over NN (operation):	-100 to +2.500 m
Housing:	Full potted PU housing
Dimension (D × L):	142 × 192 mm, without cable
Weight:	~ 6.5 kg

Flash Light (named SFL or TIL)	
Power supply:	36 VAC, 50/60 Hz (SELV)
Max. Power consumption:	EL = 20 VA IL = 20 VA
Communication interface control unit:	2-wire power line (SELV)
Environmental temperature:	-25 to +85 °C
Relative humidity, not condensed:	10 to 100%
International Protection class:	IP68
Altitude over NN (operation):	-100 to +2'500 m
Dimension, packaging (W×H×D):	EL = 300 × 300 × 190 mm IL = 310 × 310 × 190 mm
Weight:	EL = ~7.5 kg IL = ~6.9 kg
LED power (SFL configuration settings general): Standard (EL dimmed): High:	EL 12' 500 cd eff. 21' 000 cd eff.
LED power (SFL configuration settings general): Standard (EL dimmed): High:	IL 6' 500 cd eff. 6' 500 cd eff. ¹
Nominal life time:	> 50.000 h

Notes

¹ For harmonization of the visual impression the use of double inset flash lights is recommended.

RELIANCE

Dimension Inset Flash Light

12" shallow base and deep base can with transformer shown for complete view only but not part of the flash light. These articles can be ordered separately from accessory.

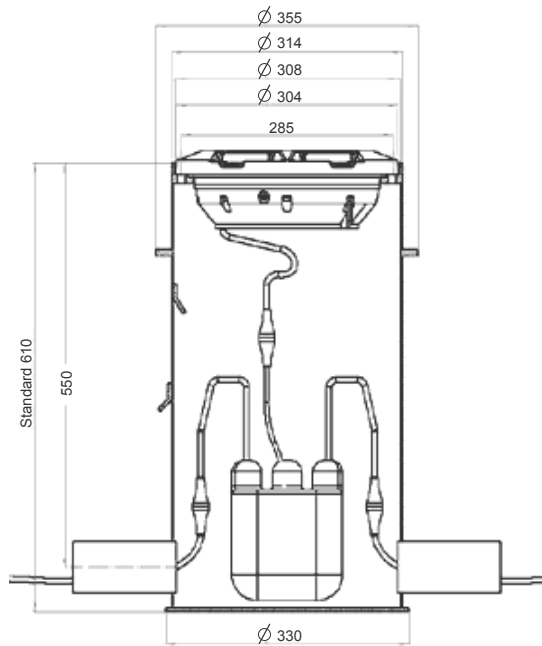
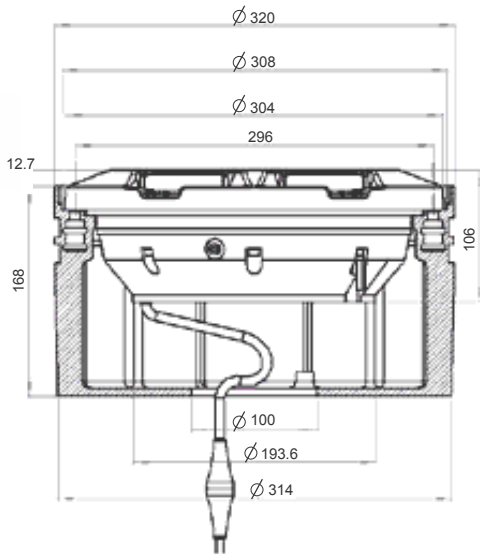

Dimension Elevated Flash Light

Base plate and frangible pedestal are not shown and are not part of the flash light. These articles can be ordered separately from accessory.

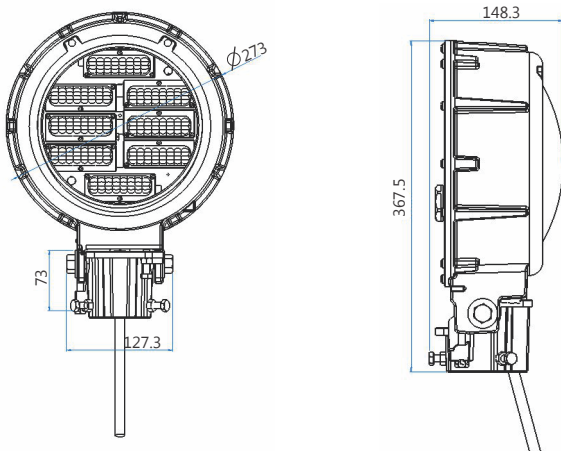

Ordering Codes

Table 1: Inset and elevated lights

Ordering Code ¹	Part	Description
817.213.5	EL 817D-SFL/TIL	Elevated Cold/W - FAA connector + receptacle ²
817.214.5	EL 817D-SFL/TIL	Elevated Cold/W - Phoenix Connector + receptacle
817.215.5	EL 817D-SFL/TIL	Elevated Cold/W - Phoenix Connector + Receptacle + FAA-lead (connector + receptacle)
817.203.5	EL 817D-SFL/TIL	Elevated Cold/W - Phoenix connector (no receptacle)
817.204.5	EL 817D-SFL/TIL	Elevated Cold/W - FAA connector (no receptacle)
868.211.1	IL868D-SFL/TIL	Single Inset Cold/W+ 1x 2m FAA 5 pole cable
868.212.1	Double Set IL868D-SFL/TIL	Double Inset Cold/W + 2x 2m 5 pole cable +1x H- Phoenix connector + 1x Phoenix connector
868.200.1	IL868D-SFL/TIL	Single Inset Cold/W - FAA 5 pole plug
868.205.1	IL868D-SFL/TIL	Single Inset Cold/W - Phoenix Connector

Notes

¹ Supply of required electric and installation parts (joint, T-joint, cabling) is not part of ADB SAFEGATE delivery but responsibility of the installer. For more details refer to manual.

² Refer to manual. 300 Ohm termination resistor of data lines delivered with MCU.

Table 2: Control cabinet and software

Ordering Code	Part	Description
MCU800D-SFL-20	MCU 800D-SFL	Multiwire
MCU800D-SFL-21	MCU 800D-SFL	CAN Bus
MCU800D-SFL-22	MCU 800D-SFL	Modbus
MCU800D-SFL-23	MCU 800D-SFL	Single Profibus
MCU800D-SFL-24	MCU 800D-SFL	Redundant Profibus
MCU800D-SFL-25	MCU 800D-SFL	Single Ethernet
MCU800D-SFL-26	MCU 800D-SFL	Redundant Ethernet
P1299	lucDMC	lucDMC + License Dongle for 1 PC
P1300	lucDMC	lucDMC + License Dongle for 2 PC
P1301	lucDMC	lucDMC + License Dongle for 3 PC
P1302	lucDMC	lucDMC + License Dongle for 4 PC
P1303	lucDMC	lucDMC + License Dongle for 5 PC
P1030	PSD800D-SFL	Dongle For Inset Lights

Table 3: Section Transformers, connection and mounting

Ordering Code	Part	Description
P864	PDU800D-SFL	SELV Isolating Unit
P1006	OLP800D-SFL	Optional Overvoltage Protection
P1029	JBX800D-SFL	T Connection Box - JBX800D
300.241	QPD Plug	Phoenix Connector Plug (QPD Nut included)
300.245	QPD Receptacle	Phoenix Connector Receptacle (QPD Nut included)
300.244	QPD H Connector	Phoenix H - Connector
300.243	QPD Dustcap	Phoenix Dustcap to seal off unused connections
300.246	QPD Nut	Phoenix Nut (To reuse Plug or Receptacle)
205.016	FAA 4 pole Cable Lead Plug	FAA 4 pole Cable Lead Plug - 280 mm
205.017	FAA 4 pole Cable Lead Receptacle	FAA 4 pole Cable Lead Receptacle -2000 mm
205.043	FAA 5 pole Cable Plug	FAA 5 pole Cable Plug - 300 mm
205.044	FAA 5 pole Cable Receptacle	FAA 5 pole Cable Receptacle - 2000 mm
061.607	Base Plate	Base plate 2" / NPS
061.186	Pedestal	Frangible pedestal
211.319	Shallow Base	Eurobase waterproof with O-Ring (OC 7080.90.650)