



L-858(L) / AGSF-L
FAA LED Airfield Guidance Sign

Spare Parts

SP_3006, Rev. A, 2020/09/18

**ADB
SAFEGATE**

A.0 Disclaimer / Standard Warranty

CE certification

The equipment listed as CE certified means that the product complies with the essential requirements concerning safety and hygiene. The European directives that have been taken into consideration in the design are available on written request to ADB SAFEGATE.

ETL certification

The equipment listed as ETL certified means that the product complies with the essential requirements concerning safety and FAA Airfield regulations. The FAA directives that have been taken into consideration in the design are available on written request to ADB SAFEGATE.

All Products Guarantee

ADB SAFEGATE will correct by repair or replacement per the applicable guarantee above, at its option, equipment or parts which fail because of mechanical, electrical or physical defects, provided that the goods have been properly handled and stored prior to installation, properly installed and properly operated after installation, and provided further that Buyer gives ADB SAFEGATE written notice of such defects after delivery of the goods to Buyer. Refer to the Safety section for more information on Material Handling Precautions and Storage precautions that must be followed.

ADB SAFEGATE reserves the right to examine goods upon which a claim is made. Said goods must be presented in the same condition as when the defect therein was discovered. ADB SAFEGATE further reserves the right to require the return of such goods to establish any claim.

ADB SAFEGATE's obligation under this guarantee is limited to making repair or replacement within a reasonable time after receipt of such written notice and does not include any other costs such as the cost of removal of defective part, installation of repaired product, labor or consequential damages of any kind, the exclusive remedy being to require such new parts to be furnished.

ADB SAFEGATE's liability under no circumstances will exceed the contract price of goods claimed to be defective. Any returns under this guarantee are to be on a transportation charges prepaid basis. For products not manufactured by, but sold by ADB SAFEGATE, warranty is limited to that extended by the original manufacturer. This is ADB SAFEGATE's sole guarantee and warranty with respect to the goods; there are no express warranties or warranties of fitness for any particular purpose or any implied warranties of fitness for any particular purpose or any implied warranties other than those made expressly herein. All such warranties being expressly disclaimed.

Standard Products Guarantee

Products of ADB SAFEGATE manufacture are guaranteed against mechanical, electrical, and physical defects (excluding lamps) which may occur during proper and normal use for a period of two years from the date of ex-works delivery, and are guaranteed to be merchantable and fit for the ordinary purposes for which such products are made.



Note

See your sales order contract for a complete warranty description.

FAA Certified product installed in the United States and purchased or funded with monies through the Airport Improvement Program (AIP) installations guarantee

ADB SAFEGATE L858 Airfield Guidance Signs are warranted against mechanical and physical defects in design or manufacture for a period of 2 years from date of installation, per FAA AC 150/5345-44 (applicable edition).

ADB SAFEGATE L858(L) Airfield Guidance Signs are warranted against electrical defects in design or manufacture of the LED or LED specific circuitry for a period of 4 years from date of installation, per FAA EB67 (applicable edition).

ADB SAFEGATE LED light fixtures (with the exception of obstruction lighting) are warranted against electrical defects in design or manufacture of the LED or LED specific circuitry for a period of 4 years from date of installation, per FAA EB67 (applicable edition).



Note

See your sales order contract for a complete warranty description.

Liability



WARNING

Use of the equipment in ways other than described in the catalog leaflet and the manual may result in personal injury, death, or property and equipment damage. Use this equipment only as described in the manual.

ADB SAFEGATE cannot be held responsible for injuries or damages resulting from non-standard, unintended uses of its equipment. The equipment is designed and intended only for the purpose described in the manual. Uses not described in the manual are considered unintended uses and may result in serious personal injury, death or property damage.

Unintended uses, includes the following actions:

- Making changes to equipment that have not been recommended or described in this manual or using parts that are not genuine ADB SAFEGATE replacement parts or accessories.
- Failing to make sure that auxiliary equipment complies with approval agency requirements, local codes, and all applicable safety standards if not in contradiction with the general rules.
- Using materials or auxiliary equipment that are inappropriate or incompatible with your ADB SAFEGATE equipment.
- Allowing unskilled personnel to perform any task on or with the equipment.

© ADB SAFEGATE BV

This manual or parts thereof may not be reproduced, stored in a retrieval system, or transmitted, in any form or by any means, electronic, mechanical, photocopying, recording, nor otherwise, without ADB SAFEGATE BV's prior written consent.

This manual could contain technical inaccuracies or typographical errors. ADB SAFEGATE BV reserves the right to revise this manual from time to time in the contents thereof without obligation of ADB SAFEGATE BV to notify any person of such revision or change. Details and values given in this manual are average values and have been compiled with care. They are not binding, however, and ADB SAFEGATE BV disclaims any liability for damages or detriments suffered as a result of reliance on the information given herein or the use of products, processes or equipment to which this manual refers. No warranty is made that the use of the information or of the products, processes or equipment to which this manual refers will not infringe any third party's patents or rights. The information given does not release the buyer from making their own experiments and tests.

TABLE OF CONTENTS

| | |
|--|-----------|
| 1.0 Safety | 1 |
| 1.1 Safety Messages | 1 |
| 1.1.1 Introduction to Safety | 2 |
| 1.1.2 Intended Use | 2 |
| 1.1.3 Material Handling Precautions: Storage | 3 |
| 2.0 Introduction | 5 |
| 2.1 FAA LED Light Bar Airfield Guidance Sign | 5 |
| 3.0 LED Light Bar Sign Parts | 9 |
| A.0 SUPPORT | 13 |
| A.1 ADB SAFEGATE Website | 13 |
| A.2 Recycling | 14 |
| A.2.1 Local Authority Recycling | 14 |
| A.2.2 ADB SAFEGATE Recycling | 14 |

List of Figures

| | |
|--|----|
| Figure 1: Size 1, Single Module Sign Parts | 10 |
| Figure 2: Sign Parts | 11 |
| Figure 3: Sign Parts | 11 |

List of Tables

| | |
|----------------------------|----|
| Table 1: Spare Parts | 10 |
|----------------------------|----|

1.0 Safety

Introduction to Safety

This section contains general safety instructions for installing and using ADB SAFEGATE equipment. Some safety instructions may not apply to the equipment in this manual. Task- and equipment-specific warnings are included in other sections of this manual where appropriate.

1.1 Safety Messages

HAZARD Icons used in the manual

For all HAZARD symbols in use, see the Safety section. All symbols must comply with ISO and ANSI standards.

Carefully read and observe all safety instructions in this manual, which alert you to safety hazards and conditions that may result in personal injury, death or property and equipment damage and are accompanied by the symbol shown below.



WARNING

Failure to observe a warning may result in personal injury, death or equipment damage.



DANGER - Risk of electrical shock or ARC FLASH

Disconnect equipment from line voltage. Failure to observe this warning may result in personal injury, death, or equipment damage. ARC Flash may cause blindness, severe burns or death.



WARNING - Wear personal protective equipment

Failure to observe may result in serious injury.



WARNING - Do not touch

Failure to observe this warning may result in personal injury, death, or equipment damage.



CAUTION

Failure to observe a caution may result in equipment damage.

Qualified Personnel



Important Information

The term **qualified personnel** is defined here as individuals who thoroughly understand the equipment and its safe operation, maintenance and repair. Qualified personnel are physically capable of performing the required tasks, familiar with all relevant safety rules and regulations and have been trained to safely install, operate, maintain and repair the equipment. It is the responsibility of the company operating this equipment to ensure that its personnel meet these requirements.

Always use required personal protective equipment (PPE) and follow safe electrical work practice.

1.1.1 Introduction to Safety



CAUTION

Unsafe Equipment Use

This equipment may contain electrostatic devices, hazardous voltages and sharp edges on components

- Read installation instructions in their entirety before starting installation.
- Become familiar with the general safety instructions in this section of the manual before installing, operating, maintaining or repairing this equipment.
- Read and carefully follow the instructions throughout this manual for performing specific tasks and working with specific equipment.
- Make this manual available to personnel installing, operating, maintaining or repairing this equipment.
- Follow all applicable safety procedures required by your company, industry standards and government or other regulatory agencies.
- Install all electrical connections to local code.
- Use only electrical wire of sufficient gauge and insulation to handle the rated current demand. All wiring must meet local codes.
- Route electrical wiring along a protected path. Make sure they will not be damaged by moving equipment.
- Protect components from damage, wear, and harsh environment conditions.
- Allow ample room for maintenance, panel accessibility, and cover removal.
- Protect equipment with safety devices as specified by applicable safety regulations
- If safety devices must be removed for installation, install them immediately after the work is completed and check them for proper functioning prior to returning power to the circuit.

Failure to follow this instruction can result in serious injury or equipment damage

Additional Reference Materials



Important Information

- IEC - International Standards and Conformity Assessment for all electrical, electronic and related technologies.
- IEC 60364 - Electrical Installations in Buildings.
- FAA Advisory: AC 150/5340-26 (current edition), Maintenance of Airport Visual Aid Facilities.
- Maintenance personnel must refer to the maintenance procedure described in the ICAO Airport Services Manual, Part 9.
- ANSI/NFPA 79, Electrical Standards for Metalworking Machine Tools.
- National and local electrical codes and standards.

1.1.2 Intended Use



CAUTION

Use this equipment as intended by the manufacturer

This equipment is designed to perform a specific function, do not use this equipment for other purposes

- Using this equipment in ways other than described in this manual may result in personal injury, death or property and equipment damage. Use this equipment only as described in this manual.

Failure to follow this instruction can result in serious injury or equipment damage

1.1.3 Material Handling Precautions: Storage



CAUTION

Improper Storage

Store this equipment properly

- If equipment is to be stored prior to installation, it must be protected from the weather and kept free of condensation and dust.

Failure to follow this instruction can result in equipment damage

2.0 Introduction

The L-858(L) / AGSF-L LED signs, designed for the FAA market, virtually eliminate runway shutdowns due to the longevity of the LED light source. They are direct replacements for existing signs, and they create a highly uniform distribution of light, eliminating hot spots and shadows. They can be powered from either a ferroresonant or thyristor type CCR and operate on 3-step, 5-step and 5.5A series circuits.



2.1 FAA LED Light Bar Airfield Guidance Sign

Compliance with Standards

| | |
|------|---|
| FAA: | L-858Y(L), L-858R(L), L-858L(L) and L-858B(L) AC 150/5345-44 (Current Edition) and the FAA Engineering Brief No. 67. ETL Certified. |
|------|---|

Uses

- FAA L-858Y(L)** Direction, Destination, and Boundary (Informational Sign)
- FAA L-858R(L)** Mandatory Sign
- FAA L-858L(L)** Runway/Taxiway Location Sign: These signs are designed to guide pilots to a particular point on the field, identify holding positions, identify taxiway and runway intersections, and prohibit aircraft entry into designated areas.
- FAA L-858B(L)** Runway Distance Remaining Sign: The L-858B is used at 1,000-foot intervals adjacent to the runway edge in order to provide runway distance remaining information to pilots during takeoff and landing operations.

Construction

Corrosion-resistant sign construction requires minimal maintenance.

- Aluminum housing
- Acrylic sign legend panels
- Stainless steel hardware
- Retroreflective sheeting
- Translucent plastic panel dividers used between multi-module legend panels

Operating Conditions

| | |
|-------------|--|
| Temperature | -40 °F to +131 °F (-40 °C to +55 °C) |
| Humidity | 0 to 100% |
| Wind | <ul style="list-style-type: none"> • ADB Safegate Mode 2 signs withstand wind velocities up to 225 mph • ADB Safegate Mode 3 signs withstand wind velocities up to 327 mph |

Sign Legends

| Type | Purpose | Legend Color | Background Color |
|--------|-----------------------------------|--------------------------|------------------|
| L-858Y | Direction, Destination & Boundary | Black | Yellow |
| L-858R | Mandatory Sign | White with Black Outline | Red |
| L-858L | Runway/Taxiway Location | Yellow | Black |
| L-858B | Runway Distance Remaining | White | Black |

Electrical Supply

Signs are internally lighted and are connected to a series circuit using the appropriately-sized 50 or 60 Hz L-830/L-831 isolation transformer.

Packaging Data

Signs are shipped with L-823 cord set(s), frangible couplings, and floor flanges –ready for installation.

| Description | Gross Weight ¹ | | Carton Dimensions | |
|------------------|---------------------------|------------------|-------------------|----------------|
| | (lb) | (kg) | (in) | (cm) |
| Size 1, Module 1 | 46 | 21 | 34 × 34 × 13 | 87 × 86.4 × 33 |
| Size 1, Module 2 | 78 | 35 | 34 × 63 × 13 | 87 × 160 × 33 |
| Size 1, Module 3 | 115 | 52 | 34 × 92 × 13 | 87 × 234 × 33 |
| Size 1, Module 4 | 169 | 77 | 34 × 121 × 13 | 87 × 307 × 33 |
| Size 2, Module 1 | 71 | 32 | 40 × 40 × 13 | 102 × 102 × 33 |
| Size 2, Module 2 | 104 | 47 | 40 × 76 × 13 | 102 × 193 × 33 |
| Size 2, Module 3 | 153 | 70 | 40 × 112 × 13 | 102 × 285 × 33 |
| Size 2, Module 4 | 220 ² | 100 ² | 40 × 147 × 13 | 102 × 374 × 33 |
| Size 3, Module 1 | 81 | 37 | 46 × 46 × 13 | 117 × 117 × 33 |
| Size 3, Module 2 | 131 | 60 | 46 × 89 × 13 | 117 × 226 × 33 |
| Size 3, Module 3 | 199 | 90 | 46 × 131 × 13 | 117 × 333 × 33 |
| Size 3, Module 4 | 252 | 114 | 46 × 173 × 13 | 117 × 440 × 33 |
| Size 4, Module 1 | 122 | 56 | 62 × 52 × 13 | 158 × 132 × 33 |
| Size 5, Module 1 | 81 | 37 | 46 × 46 × 13 | 117 × 117 × 33 |

Notes

¹ Estimated weight

² Weights listed are for halogen signs. Contact ADB Safegate for high wind speed sign weights.

Sign Load & Transformer Requirements

In the table to the right, the number for the total VA load imposed on the CCR represents the actual load imposed on the regulator and accounts for power factor and load imposed by the transformer.

| Sign Size | No. of Modules | Transformer | Power Factor | Volt Amp VA Load |
|--|----------------|-------------|--------------|------------------|
| Style 2, 3-Step LED Signs (4.8 - 6.6 A) | | | | |
| 1 | 1 | 65 W | 0.83 | 85 |
| 1 | 2 | 100 W | 0.83 | 95 |
| 1 | 3 | 100 W | 0.88 | 95 |
| 1 | 4 | 100 W | 0.91 | 95 |
| 2 | 1 | 65 W | 0.88 | 90 |
| 2 | 2 | 100 W | 0.88 | 95 |
| 2 | 3 | 100 W | 0.91 | 100 |
| 2 | 4 | 100 W | 0.91 | 100 |
| 3 | 1 | 100 W | 0.83 | 95 |
| 3 | 2 | 100 W | 0.91 | 95 |
| 3 | 3 | 100 W | 0.91 | 100 |
| 3 | 4 | 150 W | 0.88 | 115 |
| 4 | 1 | 100 W | 0.84 | 95 |
| 5 | 1 | 100 W | 0.83 | 95 |
| Style 3, 5-Step LED Signs (2.8 - 6.6 A) | | | | |
| 1 | 1 | 100 W | 0.88 | 75 |
| 1 | 2 | 150 W | 0.88 | 95 |
| 1 | 3 | 150 W | 0.88 | 95 |
| 1 | 4 | 150 W | 0.90 | 100 |
| 2 | 1 | 150 W | 0.88 | 90 |
| 2 | 2 | 150 W | 0.90 | 95 |
| 2 | 3 | 150 W | 0.83 | 100 |
| 2 | 4 | 150 W | 0.85 | 100 |
| 3 | 1 | 150 W | 0.88 | 95 |
| 3 | 2 | 150 W | 0.90 | 100 |
| 3 | 3 | 150 W | 0.83 | 100 |
| 3 | 4 | 200 W | 0.85 | 115 |
| 4 | 1 | 150 W | 0.88 | 95 |
| 5 | 1 | 150 W | 0.83 | 95 |
| Style 5, Single-Step LED Signs (5.5 A) | | | | |
| 1 | 1 | 65 W | 0.84 | 75 |
| 1 | 2 | 65 W | 0.84 | 85 |
| 1 | 3 | 100 W | 0.88 | 85 |
| 1 | 4 | 100 W | 0.88 | 95 |
| 2 | 1 | 65 W | 0.92 | 75 |
| 2 | 2 | 100 W | 0.89 | 85 |
| 2 | 3 | 100 W | 0.90 | 100 |
| 2 | 4 | 100 W | 0.90 | 100 |
| 3 | 1 | 65 W | 0.84 | 85 |
| 3 | 2 | 100 W | 0.88 | 95 |
| 3 | 3 | 100 W | 0.92 | 100 |
| 3 | 4 | 100 W | 0.92 | 110 |
| 4 | 1 | 65 W | 0.83 | 85 |
| 5 | 1 | 65 W | 0.92 | 85 |

L-858 Sign LED Retrofit Kits for ADB Safegate Signs

Application

A retrofit kit is available to convert any existing ADB Safegate tungsten-halogen or fluorescent sign to an LED light source. The same retrofit kit can be used to convert signs using LED light tubes (Part No. 48A0408 and 48A0409) to the new LED light bar design. The kit is available for all FAA Types: L-858Y, L-858R, L-858L and L-858B; all Sizes: Size 1 through 5; and all module lengths: up to 4 modules. Retrofitting a sign is fast and easy. It typically takes 20 minutes to retrofit a 2-module sign. The retrofit process converts the sign to the same type as an existing ADB Safegate ETL-Certified sign.

Reduced Maintenance costs

An LED sign virtually eliminates runway and taxiway shutdowns due to the long life LED light source. It eliminates re-lamping expenses and reduces on-going maintenance costs. The LED optical design also creates a highly uniform distribution of light, eliminating hot spots and shadows. Also, the sign provides for improved safety because there is only a low, regulated DC voltage inside sign.

Energy savings

An LED sign provides greatly reduced energy consumption compared to existing types of signs. See chart below for more information.

The LED sign operates on ferroresonant or thyristor CCRs that are designed in compliance with FAA requirements. The sign electronics are designed to operate on 3-step, 5-step and 5.5 A dedicated series circuits.

See chart on previous page for sign loading and optimum sign transformer size. Note that the existing larger size transformer, if present, can be reused. Ask for Service Bulletin ALN158 for details on how to retrofit the sign.

Dimensions

Sign Heights

| Type | Sign Size No. | Sign Face Height in (cm) | Legend Height in (cm) | Sign Style No. | Sign Class No. | Overall Mounting Height in (cm) |
|------------|---------------|--------------------------|-----------------------|----------------|----------------|---------------------------------|
| L-858Y/R/L | 1 | 18 (45.7) | 12 (30.5) | 2,3,5 | 1,2 | 29.7 (75.5) |
| L-858Y/R/L | 2 | 24 (61) | 15 (38.1) | 2,3,5 | 1,2 | 35.7 (90.8) |
| L-858Y/R/L | 3 | 30 (76.2) | 18 (45.7) | 2,3,5 | 1,2 | 41.7 (106) |
| L-858B | 4 | 48 (122) | 40 (101.6) | 2,3,5 | 1,2 | 58.2 (147.8) |
| L-858B | 5 | 30 (76.2) | 25 (63.5) | 2,3,5 | 1,2 | 41.7 (106) |

Sign Lengths - Inches (Centimeters)

| Size No. | 1 Module | 2 Module | 3 Module | 4 Module |
|----------|------------|------------|-------------|-------------|
| 1 | 29.4 (75) | 58.6 (149) | 87.9 (223) | 117.2 (298) |
| 2 | 35.9 (91) | 71.6 (182) | 107.4 (273) | 143.2 (364) |
| 3 | 42.4 (108) | 84.6 (215) | 126.9 (323) | 169.2 (430) |
| 4 | 47.9 (122) | N/A | N/A | N/A |
| 5 | 42.4 (108) | N/A | N/A | N/A |



Note

- Sign depth is 9.39 in (23.85 cm).
- See our website for additional dimension and installation information.

3.0 LED Light Bar Sign Parts

Ordering Code

Lamp Type

R = LED
S = LED High Wind¹

Sign Size

1 = Size 1
2 = Size 2
3 = Size 3
4 = Size 4
5 = Size 5

Module

1 = 1 Module
2 = 2 Module
3 = 3 Module
4 = 4 Module

Style

7 = LED Style 2, Style 3, and Style 5
A = APS

Face

1 = Single
2 = Double

Total Number of Panels

X = To be determined by the ADB Safegate Sales Department based on legend and module configurations.
3

Power

1 = Power through leg without ON/OFF switch
2 = Power through leg with ON/OFF switch
3 = Power through side without ON/OFF switch³
4 = Power through side with ON/OFF switch³
5 = Customer-provided entry without ON/OFF switch^{2,3}
6 = Customer-provided entry with ON/OFF switch^{2,3}
9 = Power through bottom without ON/OFF switch³
A = Power through bottom with ON/OFF switch³

Tether

0 = No tether³
1 = One tether on one end of sign
2 = Two tethers, one on each end
3 = One tether per leg

Notes

- Customer to provide legend information and power connection side. It is important to match power cord exit location with legend side.

¹ Use high wind signs in those locations where actual wind speed exceeds FAA specifications (Mode 3). High wind signs tested to a minimum wind load of 327 mph as recommended by FAA technical paper DOT/FAA/AR - TN00/32: Evaluation of Wind-Loading on Airport Signs. High wind signs require four anchor bolts per floor flange except Size 1, which uses the standard 2-bolt foot.

² Cord set coiled up inside side. Customer provides entry hole.

³ Not ETL Certified.

S X X X - X X X 3 X X 0

Legend Panel Divider

Size

1 = Size 1
2 = Size 2
3 = Size 3 and 5

Paint Coverage

A = Solid (black only)¹
C = Clear (paint top only)

Paint Color

R = Red
Y = Yellow
B = Black¹

Note:

¹ For option A (solid), customer must select option B (black). Option C (clear) can be paired with either red or yellow.

44A6173 - X X X

LED Light Engine Tester

44A7264-1

Battery-powered tester is used during maintenance activities to separately test a single LED light bar. Uses four size D batteries and outputs 350 mA. Output is activated using a momentary switch.

Note: Tester can also be used on all ADB Safegate SB-type LED signs.

LED Sign Retrofit Kit

94A0628 - X X 0

Size

1 = Size 1
2 = Size 2
3 = Size 3
4 = Size 4
5 = Size 5

Number of Modules

1 = 1 module
2 = 2 modules
3 = 3 modules
4 = 4 modules

Table 1: Spare Parts

| Part Number | Description |
|-------------|--|
| 62A2142 | Floor flange (2-bolt) |
| 62A2146 | Floor flange, high wind speed (4-bolt) |
| 60A2678-10 | Frangible coupling, size 1 |
| 60A2678-20 | Frangible coupling, size 2 |
| 60A2678-30 | Frangible coupling, size 3 or 5 |
| 60A2678-40 | Frangible coupling, size 4 |
| 94A0054 | Tether Assembly |
| 73A0107-72 | Cord Set 72" 16/2 FAA |
| 48A0442-16 | LED light engine (bar), Size 1 and 4 ¹ |
| 48A0442-24 | LED light engine (bar), Size 2 |
| 48A0442-32 | LED light engine (bar), Size 3 and 5 |
| 44A6920 | LED sign power supply lead assy |
| 44A6921/5 | LED sign lead terminator with resistor (see wiring diag) |
| 44A6922-18 | LED sign lead jumper assy 18" |
| 44A7260-010 | LED sign power supply assembly (bar) |

Notes

¹ Size 4 signs require (qty 2) LED light engines (bars) per sign

Figure 1: Size 1, Single Module Sign Parts

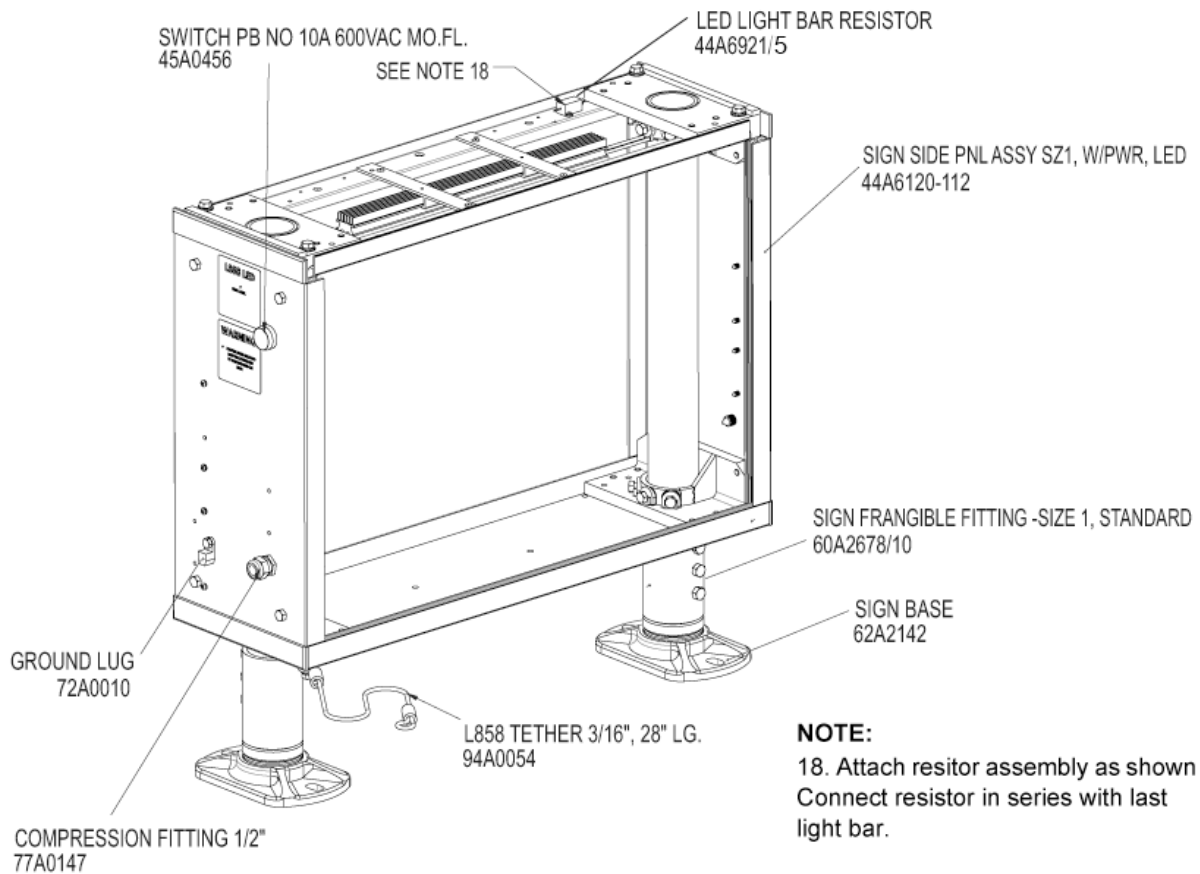



Note

TORQUE ALL:

5/16-18 bolts to 115 ± 10 inch-pounds, (13 ± 1 N•m) (except: top cover lid bolts)

Torque 5/16-18 top cover lid bolts to 50 ± 5 lb/in (5.7 ± 0.6 N•m).

3/8-16 bolts to 200 ± 10 inch-pounds (22.6 ± 1 N•m)

Figure 2: Sign Parts

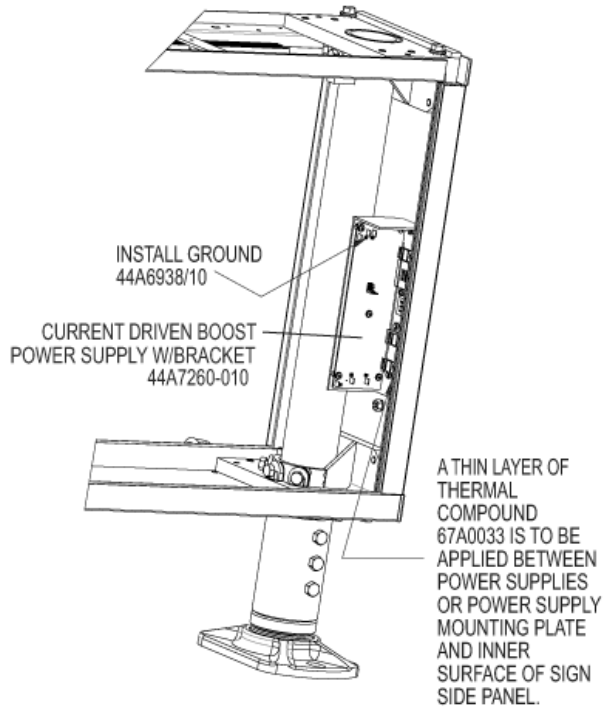
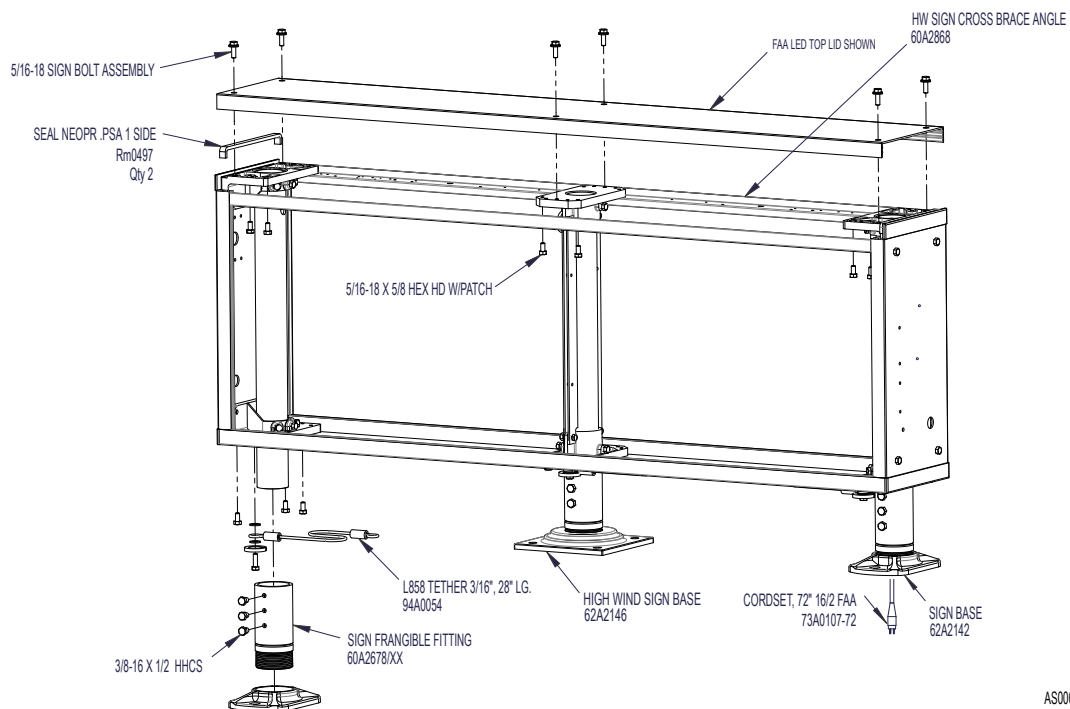

Figure 3: Sign Parts



AS00029-XXX-01 REV: C



Note

TORQUE ALL:

5/16-18 bolts to 115 ± 10 inch-pounds, (13 ± 1 N•m) (except: top cover lid bolts)

Torque 5/16-18 top cover lid bolts to 50 ± 5 lb/in (5.7 ± 0.6 N•m).

3/8-16 bolts to 200 ± 10 inch-pounds (22.6 ± 1 N•m)

Appendix A: SUPPORT

Our experienced engineers are available for support and service at all times, 24 hour/7 days a week. They are part of a dynamic organization making sure the entire ADB SAFEGATE is committed to minimal disturbance for airport operations.

ADB SAFEGATE Support

Live Technical Support - Americas

If at any time you have a question or concern about your product, just contact ADB SAFEGATE's technical service department. Trained in all areas of system issues, troubleshooting, quality control and technical assistance, our highly experienced Technical support specialists are available 24 hours a day, seven days a week to provide assistance over the phone.

ADB SAFEGATE **Americas Technical Service & Support (US & Canada): +1-800-545-4157**

ADB SAFEGATE Americas Technical Service & Support (International): +1-614-861-1304

During regular business hours, you can also Chat with a Service Technician. We look forward to working with you!

Before You Call

When you have an airfield lighting or system control system problem it is our goal to support airfield maintenance staff as quickly as possible. To support this effort we ask that you have the following information ready before calling.

- The *airport code*
- If not with an airport, then company name (prefer customer id number)
- Contact phone number and email address
- Product with part number preferable or product number
- Have you reviewed the product's manual and troubleshooting guide
- Do you have a *True RMS* meter available (and any other necessary tools)
- Be located with the product ready to troubleshoot

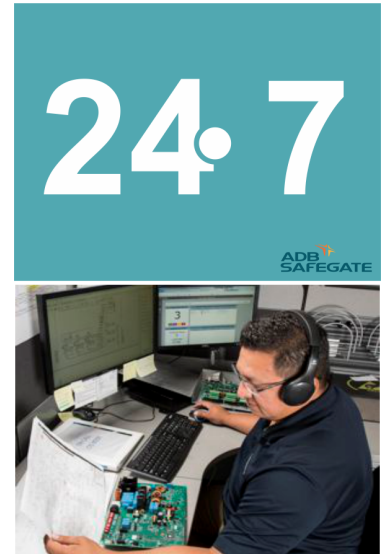

Note

For more information, see www.adbsafegate.com, or contact ADB SAFEGATE Support via email at support@adbsafegate.com or

Brussels: +32 2 722 17 11

Rest of Europe: +46 (0) 40 699 17 40

Americas: +1 614 861 1304. Press 3 for technical service or press 4 for sales support.

China: +86 (10) 8476 0106

A.1 ADB SAFEGATE Website

The ADB SAFEGATE website, www.adbsafegate.com, offers information regarding our airport solutions, products, company, news, links, downloads, references, contacts and more.

A.2 Recycling

A.2.1 Local Authority Recycling

The disposal of ADB SAFEGATE products is to be made at an applicable collection point for the recycling of electrical and electronic equipment. The correct disposal of equipment prevents any potential negative consequences for the environment and human health, which could otherwise be caused by inappropriate waste handling. The recycling of materials helps to conserve natural resources. For more detailed information about recycling of products, contact your local authority city office.

A.2.2 ADB SAFEGATE Recycling

ADB SAFEGATE is fully committed to environmentally-conscious manufacturing with strict monitoring of our own processes as well as supplier components and sub-contractor operations. ADB SAFEGATE offers a recycling program for our products to all customers worldwide, whether or not the products were sold within the EU.

ADB SAFEGATE products and/or specific electrical and electronic component parts which are fully removed/separated from any customer equipment and returned will be accepted for our recycling program.

All items returned must be clearly labeled as follows:

- For *ROHS/WEEE* Recycling
- Sender contact information (Name, Business Address, Phone number).
- Main Unit Serial Number.

ADB SAFEGATE will continue to monitor and update according for any future requirements for *EU directives* as and when *EU member states* implement new *regulations* and or *amendments*. It is our aim to maintain our *compliance plan* and assist our customers.

Company Addresses

| | |
|---|--|
| ADB SAFEGATE | ADB SAFEGATE, Belgium: Leuvensesteenweg 585, B-1930 Zaventem Belgium |
| Contact: Tel.: +32 2 722 17 11, Fax: +32 2 722 17 64 | Email: marketing@adbsafegate.com Internet: www.adbsafegate.com |
| Americas LLC | ADB SAFEGATE, Americas: 977 Gahanna Parkway, Columbus, OH 43230 USA |
| Contact: Tel.: +1 (614) 861 1304, Fax: +1 (614) 864 2069 | Email: sales.us@adbsafegate.com Internet: www.adbsafegate.com |
| ADB SAFEGATE Sweden AB | ADB SAFEGATE, Sweden: Djurhagegatan 19 SE-213 76 Malmö Sweden |
| Contact: Tel.: +46 (0)40 699 17 00, Fax: +46 (0)40 699 17 30 | Email: marketing@adbsafegate.com Internet: www.adbsafegate.com |
| ADB SAFEGATE Airfield Technologies Ltd. China | ADB SAFEGATE, China: Unit 603, D Block, CAMIC International Convention Center, No 3, Hua Jia Di East road, ChaoYang district, Beijing 100102 P.R. China |
| Contact: Tel.: +86 (10) 8476 0106, Fax: +86 (10) 8476 0090 | Email: china@safegate.com Internet: www.adbsafegate.com |
| ADB SAFEGATE Germany GmbH | ADB SAFEGATE Germany GmbH, Mannheim: Konrad-Zuse-Ring 6, D-68163 Mannheim Germany |
| Contact: Tel.: +49 (621) 87 55 76-0, Fax: +49 (621) 87 55 76-55 | Email: marketing@adbsafegate.com Internet: www.adbsafegate.com |



Powering Your Airport Performance from Approach to Departure

adbsafegate.com

Copyright © ADB SAFEGATE, all rights reserved

