



SafeLED Sign
Guidance Sign and Gate Sign

User Manual

UM-0160, Rev. 3.1, 2020/03/19

**ADB
SAFEGATE**

A.0 Disclaimer / Standard Warranty

CE certification

The equipment listed as CE certified means that the product complies with the essential requirements concerning safety and hygiene. The European directives that have been taken into consideration in the design are available on written request to ADB SAFEGATE.

ETL certification

The equipment listed as ETL certified means that the product complies with the essential requirements concerning safety and FAA Airfield regulations. The FAA directives that have been taken into consideration in the design are available on written request to ADB SAFEGATE.

All Products Guarantee

ADB SAFEGATE will correct by repair or replacement per the applicable guarantee above, at its option, equipment or parts which fail because of mechanical, electrical or physical defects, provided that the goods have been properly handled and stored prior to installation, properly installed and properly operated after installation, and provided further that Buyer gives ADB SAFEGATE written notice of such defects after delivery of the goods to Buyer. Refer to the Safety section for more information on Material Handling Precautions and Storage precautions that must be followed.

ADB SAFEGATE reserves the right to examine goods upon which a claim is made. Said goods must be presented in the same condition as when the defect therein was discovered. ADB SAFEGATE further reserves the right to require the return of such goods to establish any claim.

ADB SAFEGATE's obligation under this guarantee is limited to making repair or replacement within a reasonable time after receipt of such written notice and does not include any other costs such as the cost of removal of defective part, installation of repaired product, labor or consequential damages of any kind, the exclusive remedy being to require such new parts to be furnished.

ADB SAFEGATE's liability under no circumstances will exceed the contract price of goods claimed to be defective. Any returns under this guarantee are to be on a transportation charges prepaid basis. For products not manufactured by, but sold by ADB SAFEGATE, warranty is limited to that extended by the original manufacturer. This is ADB SAFEGATE's sole guarantee and warranty with respect to the goods; there are no express warranties or warranties of fitness for any particular purpose or any implied warranties of fitness for any particular purpose or any implied warranties other than those made expressly herein. All such warranties being expressly disclaimed.

Standard Products Guarantee

Products of ADB SAFEGATE manufacture are guaranteed against mechanical, electrical, and physical defects (excluding lamps) which may occur during proper and normal use for a period of two years from the date of ex-works delivery, and are guaranteed to be merchantable and fit for the ordinary purposes for which such products are made.



Note

See your sales order contract for a complete warranty description.

FAA Certified product installed in the United States or in US Military installations guarantee

ADB SAFEGATE L858 Airfield Guidance Signs are warranted against mechanical and physical defects in design or manufacture for a period of 2 years from date of installation, per FAA AC 150/5345-44 (applicable edition).

ADB SAFEGATE L858(L) Airfield Guidance Signs are warranted against electrical defects in design or manufacture of the LED or LED specific circuitry for a period of 4 years from date of installation, per FAA EB67 (applicable edition).

ADB SAFEGATE LED light fixtures (with the exception of obstruction lighting) are warranted against electrical defects in design or manufacture of the LED or LED specific circuitry for a period of 4 years from date of installation, per FAA EB67 (applicable edition).



Note

See your sales order contract for a complete warranty description.

Liability



WARNING

Use of the equipment in ways other than described in the catalog leaflet and the manual may result in personal injury, death, or property and equipment damage. Use this equipment only as described in the manual.

ADB SAFEGATE cannot be held responsible for injuries or damages resulting from non-standard, unintended uses of its equipment. The equipment is designed and intended only for the purpose described in the manual. Uses not described in the manual are considered unintended uses and may result in serious personal injury, death or property damage.

Unintended uses, includes the following actions:

- Making changes to equipment that have not been recommended or described in this manual or using parts that are not genuine ADB SAFEGATE replacement parts or accessories.
- Failing to make sure that auxiliary equipment complies with approval agency requirements, local codes, and all applicable safety standards if not in contradiction with the general rules.
- Using materials or auxiliary equipment that are inappropriate or incompatible with your ADB SAFEGATE equipment.
- Allowing unskilled personnel to perform any task on or with the equipment.

© ADB SAFEGATE BV

This manual or parts thereof may not be reproduced, stored in a retrieval system, or transmitted, in any form or by any means, electronic, mechanical, photocopying, recording, nor otherwise, without ADB SAFEGATE BV's prior written consent.

This manual could contain technical inaccuracies or typographical errors. ADB SAFEGATE BV reserves the right to revise this manual from time to time in the contents thereof without obligation of ADB SAFEGATE BV to notify any person of such revision or change. Details and values given in this manual are average values and have been compiled with care. They are not binding, however, and ADB SAFEGATE BV disclaims any liability for damages or detriments suffered as a result of reliance on the information given herein or the use of products, processes or equipment to which this manual refers. No warranty is made that the use of the information or of the products, processes or equipment to which this manual refers will not infringe any third party's patents or rights. The information given does not release the buyer from making their own experiments and tests.

TABLE OF CONTENTS

1.0 Safety	1
1.1 Safety Messages.....	1
1.1.1 Introduction to Safety.....	2
1.1.2 Intended Use.....	2
1.1.3 Material Handling Precautions: Storage.....	3
1.1.4 Material Handling: Heavy Equipment.....	3
1.1.5 Material Handling Precautions: Fasteners.....	3
1.1.6 Operation Safety.....	4
1.1.7 Maintenance Safety.....	4
1.1.8 Material Handling Precautions, ESD.....	5
1.1.9 Arc Flash and Electric Shock Hazard.....	5
2.0 About this manual	7
3.0 Introduction	9
3.1 Guidance Sign and Gate Sign.....	9
4.0 Installation	15
4.1 Standard hardware and preparation.....	15
4.1.1 Tools to use	17
4.1.2 External electrical connections.....	18
4.1.3 Mounting system.....	18
4.2 Mounting a Tether wire.....	21
4.2.1 Tether wire - without pre-drilled holes	21
4.2.2 Tether wire - with pre-drilled holes.....	24
4.3 Electrical connection.....	25
4.4 Bird deterrent spikes (Optional).....	26
4.5 Reflective tape.....	27
4.6 Gate Sign.....	27
5.0 Operation	29
6.0 Maintenance	31
6.1 Replace a front panel	31
6.2 Replace a LED-strip.....	32
6.3 Replace an adapter card.....	35
6.4 Replace a converter	37
6.5 Replace a damaged power cable.....	39
6.6 Replace a frangible coupling.....	41
7.0 Troubleshooting	43
7.1 The sign does not light up correctly.....	43
7.2 The sign has mechanical issues.....	43
7.3 Internal Wiring - Series Powered LED.....	44
7.4 Internal Wiring - Voltage Powered LED.....	45
8.0 Spare Parts	47
8.1 SafeLED Sign	47
9.0 SUPPORT	53
9.1 ADB SAFEGATE website.....	53
9.2 Recycling.....	53
9.2.1 Local authority recycling.....	53
9.2.2 ADB SAFEGATE recycling.....	54
A.1.0 Mounting before version 5.0	55
A.2.0 Replace a front panel version 1.0 to 2.0	59
A.3.0 Replace a LED-strip version 1.0 to 2.5	61

A.4.0 Tethering chain..... 63

1.0 Safety

Introduction to Safety

This section contains general safety instructions for installing and using ADB SAFEGATE equipment. Some safety instructions may not apply to the equipment in this manual. Task- and equipment-specific warnings are included in other sections of this manual where appropriate.

1.1 Safety Messages

HAZARD Icons used in the manual

For all HAZARD symbols in use, see the Safety section. All symbols must comply with ISO and ANSI standards.

Carefully read and observe all safety instructions in this manual, which alert you to safety hazards and conditions that may result in personal injury, death or property and equipment damage and are accompanied by the symbol shown below.



WARNING

Failure to observe a warning may result in personal injury, death or equipment damage.



DANGER - Risk of electrical shock or ARC FLASH

Disconnect equipment from line voltage. Failure to observe this warning may result in personal injury, death, or equipment damage. ARC Flash may cause blindness, severe burns or death.



WARNING - Wear personal protective equipment

Failure to observe may result in serious injury.



WARNING - Do not touch

Failure to observe this warning may result in personal injury, death, or equipment damage.



CAUTION

Failure to observe a caution may result in equipment damage.

Qualified Personnel



Important Information

The term **qualified personnel** is defined here as individuals who thoroughly understand the equipment and its safe operation, maintenance and repair. Qualified personnel are physically capable of performing the required tasks, familiar with all relevant safety rules and regulations and have been trained to safely install, operate, maintain and repair the equipment. It is the responsibility of the company operating this equipment to ensure that its personnel meet these requirements.

Always use required personal protective equipment (PPE) and follow safe electrical work practice.

1.1.1 Introduction to Safety



CAUTION

Unsafe Equipment Use

This equipment may contain electrostatic devices, hazardous voltages and sharp edges on components

- Read installation instructions in their entirety before starting installation.
- Become familiar with the general safety instructions in this section of the manual before installing, operating, maintaining or repairing this equipment.
- Read and carefully follow the instructions throughout this manual for performing specific tasks and working with specific equipment.
- Make this manual available to personnel installing, operating, maintaining or repairing this equipment.
- Follow all applicable safety procedures required by your company, industry standards and government or other regulatory agencies.
- Install all electrical connections to local code.
- Use only electrical wire of sufficient gauge and insulation to handle the rated current demand. All wiring must meet local codes.
- Route electrical wiring along a protected path. Make sure they will not be damaged by moving equipment.
- Protect components from damage, wear, and harsh environment conditions.
- Allow ample room for maintenance, panel accessibility, and cover removal.
- Protect equipment with safety devices as specified by applicable safety regulations
- If safety devices must be removed for installation, install them immediately after the work is completed and check them for proper functioning prior to returning power to the circuit.

Failure to follow this instruction can result in serious injury or equipment damage

Additional Reference Materials



Important Information

- IEC - International Standards and Conformity Assessment for all electrical, electronic and related technologies.
- IEC 60364 - Electrical Installations in Buildings.
- FAA Advisory: AC 150/5340-26 (current edition), Maintenance of Airport Visual Aid Facilities.
- Maintenance personnel must refer to the maintenance procedure described in the ICAO Airport Services Manual, Part 9.
- ANSI/NFPA 79, Electrical Standards for Metalworking Machine Tools.
- National and local electrical codes and standards.

1.1.2 Intended Use



CAUTION

Use this equipment as intended by the manufacturer

This equipment is designed to perform a specific function, do not use this equipment for other purposes

- Using this equipment in ways other than described in this manual may result in personal injury, death or property and equipment damage. Use this equipment only as described in this manual.

Failure to follow this instruction can result in serious injury or equipment damage

1.1.3 Material Handling Precautions: Storage



CAUTION

Improper Storage

Store this equipment properly

- If equipment is to be stored prior to installation, it must be protected from the weather and kept free of condensation and dust.

Failure to follow this instruction can result in equipment damage

1.1.4 Material Handling: Heavy Equipment



DANGER

Unstable load

Use caution when moving heavy equipment

- Use extreme care when moving heavy equipment.
- Verify that the moving equipment is rated to handle the weight.
- When removing equipment from a shipping pallet, carefully balance and secure it using a safety strap.

Failure to follow this instruction can result in death, serious injury, or equipment damage

1.1.5 Material Handling Precautions: Fasteners



DANGER

Foreign Object Damage - FOD

This equipment may contain fasteners that may come loose - torque properly.

- Only use fasteners of the same type as the one originally supplied with the equipment.
- Use of incorrect combination of gaskets, bolts and nuts can create severe damages to the product installation and create safety risk .
- You need to know what base the light fixture will be installed in, in order to chose the correct gasket, bolts and nuts.
- Bolt type, length, and torque value are determined by type of base, height of spacers used, and clamp force required in FAA Engineering Brief No 83 (latest revision).
- Due to the risk of bolts vibrating loose, do not use any type of washer with the fixing bolts (such as split lock washers) other than an anti-vibration washer. Anti-vibration washers as defined in FAA EB 83 (latest edition) must be used. For installations other than FAA, use the base can manufacturer's recommendations.
- Always tighten the fasteners to the recommended torque. Use a calibrated torque wrench and apply the recommended adhesive type.
- Obey the instructions of the adhesives necessary for the fasteners.

Failure to follow these warnings may cause the fasteners to loosen, damage the equipment, potentially to loosen the equipment. This can lead to a highly dangerous situation of FOD, with potential lethal consequences.



Note

To minimize the risk of errors, the ADB SAFEGATE Sales Representative will have information on which gasket goes with which base. This information is also provided in the product Data sheets, the User Manuals and the Spare Part Lists.



CAUTION

Use of incorrect combination of gaskets, bolts and nuts can create severe damages to the product installation and create multiple safety risks.

To obtain a safe and watertight installation the O-ring and retaining bolt stated in the document must be used.

You need to know what base the light fixture will be installed in, in order to choose the correct gasket, bolts and nuts.

Failure to follow these cautions can result in equipment damage or aircraft FOD.

1.1.6 Operation Safety



CAUTION

Improper Operation

Do Not Operate this equipment other than as specified by the manufacturer

- Only qualified personnel, physically capable of operating the equipment and with no impairments in their judgment or reaction times, should operate this equipment.
- Read all system component manuals before operating this equipment. A thorough understanding of system components and their operation will help you operate the system safely and efficiently.
- Before starting this equipment, check all safety interlocks, fire-detection systems, and protective devices such as panels and covers. Make sure all devices are fully functional. Do not operate the system if these devices are not working properly. Do not deactivate or bypass automatic safety interlocks or locked-out electrical disconnects or pneumatic valves.
- Protect equipment with safety devices as specified by applicable safety regulations.
- If safety devices must be removed for installation, install them immediately after the work is completed and check them for proper functioning.
- Route electrical wiring along a protected path. Make sure they will not be damaged by moving equipment.
- Never operate equipment with a known malfunction.
- Do not attempt to operate or service electrical equipment if standing water is present.
- Use this equipment only in the environments for which it is rated. Do not operate this equipment in humid, flammable, or explosive environments unless it has been rated for safe operation in these environments.
- Never touch exposed electrical connections on equipment while the power is ON.

Failure to follow these instructions can result in equipment damage

1.1.7 Maintenance Safety



DANGER

Electric Shock Hazard

This equipment may contain electrostatic devices

- Do not operate a system that contains malfunctioning components. If a component malfunctions, turn the system OFF immediately.
- Disconnect and lock out electrical power.
- Allow only qualified personnel to make repairs. Repair or replace the malfunctioning component according to instructions provided in its manual.

Failure to follow these instructions can result in death or equipment damage

1.1.8 Material Handling Precautions, ESD



CAUTION

Electrostatic Sensitive Devices

This equipment may contain electrostatic devices

- Protect from electrostatic discharge.
- Electronic modules and components should be touched only when this is unavoidable e.g. soldering, replacement.
- Before touching any component of the cabinet you shall bring your body to the same potential as the cabinet by touching a conductive earthed part of the cabinet.
- Electronic modules or components must not be brought in contact with highly insulating materials such as plastic sheets, synthetic fiber clothing. They must be laid down on conductive surfaces.
- The tip of the soldering iron must be grounded.
- Electronic modules and components must be stored and transported in conductive packing.

Failure to follow this instruction can result in equipment damage

1.1.9 Arc Flash and Electric Shock Hazard



DANGER

Series Circuits have Hazardous Voltages

This equipment produces high voltages to maintain the specified current - Do NOT Disconnect while energized.

- Allow only qualified personnel to perform maintenance, troubleshooting, and repair tasks.
- Only persons who are properly trained and familiar with ADB SAFEGATE equipment are permitted to service this equipment.
- An open airfield current circuit is capable of generating >5000 Vac and may appear OFF to a meter.
- Never unplug a device from a constant current circuit while it is operating; Arc flash may result.
- Disconnect and lock out electrical power.
- Always use safety devices when working on this equipment.
- Follow the recommended maintenance procedures in the product manuals.
- Do not service or adjust any equipment unless another person trained in first aid and CPR is present.
- Connect all disconnected equipment ground cables and wires after servicing equipment. Ground all conductive equipment.
- Use only approved ADB SAFEGATE replacement parts. Using unapproved parts or making unapproved modifications to equipment may void agency approvals and create safety hazards.
- Check the interlock systems periodically to ensure their effectiveness.
- Do not attempt to service electrical equipment if standing water is present. Use caution when servicing electrical equipment in a high-humidity environment.
- Use tools with insulated handles when working with airfield electrical equipment.

Failure to follow these instructions can result in death or equipment damage

2.0 About this manual

This document includes SafeLED airfield signs information with focus on safety, installation and maintenance procedures.

For more information, see www.adbsafegate.com.



Note

It is very important to read this document before any work is started.

3.0 Introduction

3.1 Guidance Sign and Gate Sign

Compliance with Standards

ICAO:	Annex 14 Volume I (Current edition)
ICAO:	Aerodrome design manual part 4 and 6
IEC:	61827
STAC	

Uses

- Information Sign
- Mandatory Instruction Sign
- Aircraft Stand Identification Sign

SafeLED illuminated airfield guidance signs are used as information, mandatory instruction, position and direction indicators in accordance with ICAO Annex 14, Section 5.4 Signs. The signs are available with 322km/h (Mode 2) or 480km/h (Mode 3) wind load requirements as an option.

SafeLED illuminated gate signs are used as aircraft stand identification sign in accordance with ICAO Annex 14, Section 5.4 Signs.

The sign construction includes a housing made from aluminum and a display front of UV-resistant plastic.

SafeLED signs are available in two versions according to power requirements:

Power	Light
Constant Current Regulator (Series Fed)	Current range 2.8 - 6.6 A 14-45 W LED modules
Mains Power System (Parallel system)	Voltage range 120–240 VAC, 50/60 Hz 14-45 W LED modules

Features & Benefits

LED-based light source

LED technology offers a long lasting light source, low power consumption, a technology which is environmentally friendly and robust to vibration. By using SafeLED Signs the maintenance cost of signs and airport operation interruptions is dramatically reduced.

LED technology secures a future proof airfield sign investment and removes the uncertainty of the proposed international phase out regulations for the traditional incandescent lamps.

Designed for harsh environments

SafeLED Sign is designed for use in harsh environments. The electronic components are encapsulated in waterproof polyurethane and are well protected from wear and tear. Housings are anodized aluminum and fixings are stainless steel. Component life cycle is dramatically extended and operational lifespan is greatly increased. There is also built-in surge and lightning protection. The front plate is made of UV-resistant polycarbonate to withstand jet blasts and other external forces. To ensure a long life for the sign, the LED strip is tested and certified for IP67 protection.

Technical Data

Table 1: Series Circuit

Characteristics	Symbol	Min	Max	Unit
Supply current from series circuit (50 or 60Hz) with 3-7 intensity levels CCR	I_{SUPPLY}	2.8	6.6	A_{RMS}

Table 2: Total Power Consumption - Power Factor (PF) typically >0.95

Characteristics	Symbol	Min	Max	Unit
700 x 1150 mm @ 6.6 A_{RMS}	P_{tot}	-	23	W
700 x 1300 mm @ 6.6 A_{RMS}	P_{tot}	-	25	W
700 x 1600 mm @ 6.6 A_{RMS}	P_{tot}	-	29	W
700 x 1800 mm @ 6.6 A_{RMS}	P_{tot}	-	30	W
700 x 2100 mm @ 6.6 A_{RMS}	P_{tot}	-	35	W
700 x 2500 mm @ 6.6 A_{RMS}	P_{tot}	-	40	W
700 x 2650 mm @ 6.6 A_{RMS}	P_{tot}	-	42	W
700 x 3000 mm @ 6.6 A_{RMS}	P_{tot}	-	46	W
900 x 1150 mm @ 6.6 A_{RMS}	P_{tot}	-	27	W
900 x 1300 mm @ 6.6 A_{RMS}	P_{tot}	-	29	W
900 x 1600 mm @ 6.6 A_{RMS}	P_{tot}	-	34	W
900 x 1800 mm @ 6.6 A_{RMS}	P_{tot}	-	37	W
900 x 2100 mm @ 6.6 A_{RMS}	P_{tot}	-	41	W
900 x 2500 mm @ 6.6 A_{RMS}	P_{tot}	-	47	W
900 x 2650 mm @ 6.6 A_{RMS}	P_{tot}	-	50	W
900 x 3000 mm @ 6.6 A_{RMS}	P_{tot}	-	55	W
900 x 900 mm Gate sign @ 230VAC	P_{tot}	-	22	W
1200 x 1200 mm Gate sign @ 230VAC	P_{tot}	-	32	W

Table 3: Environment

Characteristics	Symbol	Min	Max	Unit
Operating humidity range	RH	0	100	%
Operating temperature range	T_A	-40	+70	°C
Storage temperature range	T_{STG}	-60	+80	°C

Table 4: General description

Name	Description
Power Supply	An integrated, encapsulated electronic converter for series circuits (2.8-6.6A) or mains power (120/230Vac). Power Factor (PF) typically >0.95
Optics	Transilluminating LEDs, no reflectors are used. UV-resistant polycarbonate front panel is printed on the back side with UV-resistant color.
	 Note Lifetime of LEDs depends on operation.
Photometry	Distribution and homogeneity comply with ICAO Annex 14.
Color	Complying with ICAO Annex 14.
Finish	External parts are made of aluminum alloy and polycarbonate. All fixings and fastening are stainless steel.

 **Note**
 For more information about the product, including manuals and certifications, please see the Product Center on our website, www.adbsafegate.com.

Standard Outer Dimensions

Guidance signs	Measurement (mm)
Height	700, 900
Width	1150, 1300, 1600, 1800, 2100, 2500, 2650 and 3000
Gate signs	Measurement (mm)
Height × width	900 × 900 and 1200 × 1200

 **Note**
 900 × 900 mm sign fits stand number.
 1200 × 1200 mm fits stand number and coordinates.
 When installed, the total sign heights mounted on poles increases by 100 mm. The height and width of the sign including frame is 100 mm more than the visible front area.

Construction

SafeLED Sign components

Figure 1: Sign front

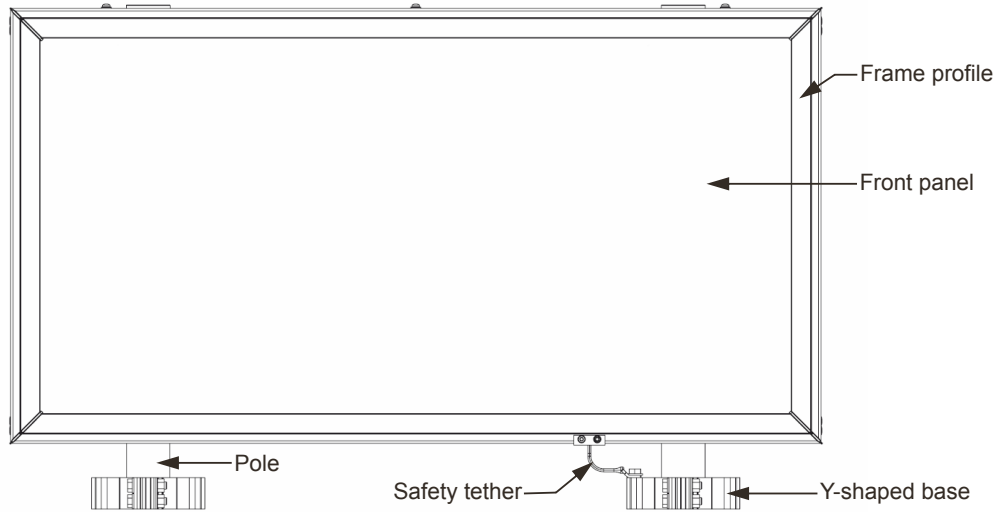
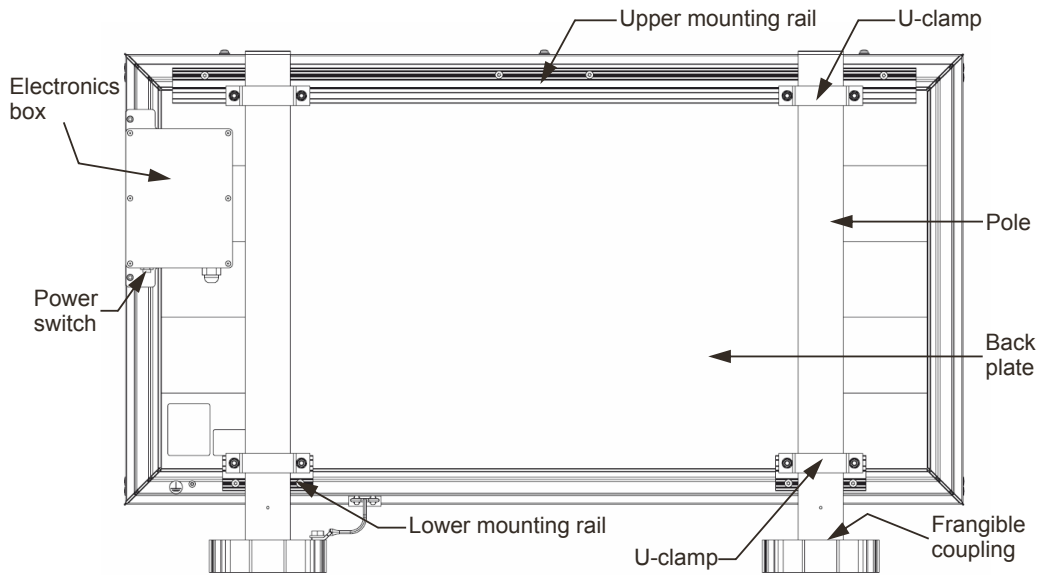
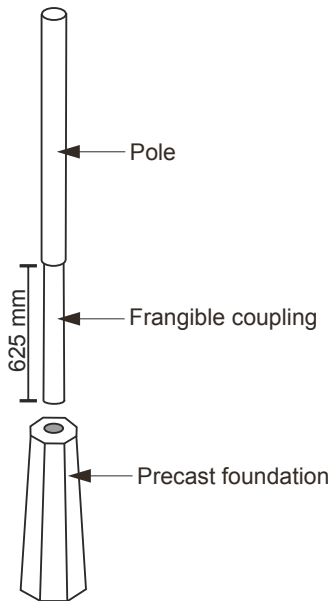

Figure 2: Sign back



Precast foundation (Optional)

Precast foundations are optional. Collar shims are **not** included as part of the sign assemblies. The frangible couplings are only designed to be with foundations that accept 60 mm diameter pipe and have an insertion depth for the pipe of 625 mm.



Note

All descriptions and photometric characteristics in this publication present only general particulars and shall not form part of any contract. The right is reserved to change them without prior notification.

4.0 Installation

This section describes the different steps for successful installation of the sign.

Site planning and preparation is required before installation, according to ICAO Annex 14. For example, there are requirements for placement near runways, taxiways and intersections, and requirements for mounting on solid, flat, level surfaces.

4.1 Standard hardware and preparation

Signs are delivered with mounting hardware including poles, frangible couplings, mounting profiles, clamps, and mounting bases.

Poles and frangible couplings measurement

The sign length determines the number of poles required and delivered for installation. When installed, the total sign height mounted on poles increases by 100 mm.

The sign length and height dimensions in the table refers to the outer dimensions of the frame. The length and height of the face are 100 mm less the values below.

Table 5: Wind load requirement ICAO 322 km/h

Sign size (mm)	Number of poles	Frangible coupling	C-C distances (mm)
700 x 1150	2	FC 1.8	700
700 x 1300	2	FC 1.8	850
700 x 1600	2	FC 1.8	1150
700 x 1800	2	FC 2.2	1350
700 x 2100	3	FC 1.8	830
700 x 2500	3	FC 1.8	1030
700 x 2650	4	FC 1.6	730
700 x 3000	4	FC 1.8	850
900 x 1150	2	FC 2.6	700
900 x 1300	2	FC 2.6	850
900 x 1600	2	FC 2.6	1150
900 x 1800	2	FC 3.1	1350
900 x 2100	3	FC 2.2	830
900 x 2500	3	FC 2.6	1030
900 x 2650	3	FC 2.6	1100
900 x 3000	4	FC 2.6	850

Table 6: Wind load requirement ICAO 480 km/h and FAA Mode 3

Sign size (mm)	Number of poles	Frangible coupling	C-C distances (mm)
700 x 1150	2	FC 3.8	700
700 x 1300	2	FC 3.8	850
700 x 1600	3	FC 3.1	580
700 x 1800	3	FC 3.1	680
700 x 2100	3	FC 3.8	830

Table 6: Wind load requirement ICAO 480 km/h and FAA Mode 3 (continued)

Sign size (mm)	Number of poles	Frangible coupling	C-C distances (mm)
700 x 2500	4	FC 3.1	680
700 x 2650	4	FC 3.1	730
700 x 3000	4	FC 3.8	850
900 x 1150	3	FC 3.8	350
900 x 1300	3	FC 3.8	425
900 x 1600	4	FC 3.1	285
900 x 1800	4	FC 3.1	450
900 x 2100	4	FC 3.8	550
900 x 2500	5	FC 3.8	515
900 x 2650	5	FC 3.8	550
900 x 3000	5	FC 3.8	640
1200 x 1200	5	FC 3.1	190

Mounting information

The mounting distances between the poles are dependent on the sign length. The mounting bases and poles are mounted in foundations, preferably concrete, installed on the surface of the sign location. The number of foundations required is equal to the number of poles.

General recommendations, dimensions and appearance of mounting bases:

- Three M12 anchor bolts per base to fasten them to the foundation.
- The anchor bolts must be installed on a diameter of 180 mm with 120° spacing to mate with the base.
- Use the correct Center to Center (C-C) mounting distance, to layout anchoring points on the surface according to the sign length and where the sign is to be installed. For information, see [Table 5](#) and [Table 6](#).

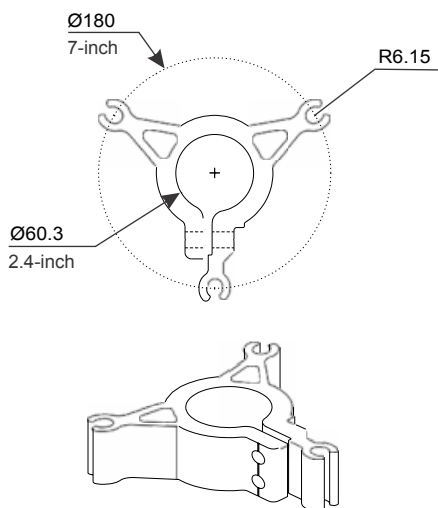

Poles and frangible couplings delivery

Poles with their respective frangible couplings are assembled at the factory. All poles are shipped in the same crate and packaged in groups of 2, 3 or 4 poles, to help indicate which sign they are to be used with.

Frangible couplings are not universal, meaning there are different models intended to be used with different sign sizes. Check the label in the lower left corner at the back of the sign to make sure that the sign is installed with the correct frangible coupling. Make sure to verify the latest recommended frangible coupling, depending on SafeLED Sign model, and apply what is indicated in the spare parts. See [SafeLED Sign](#) and www.adbsafegate.com.

For information regarding the number of poles for each sign length, see [Poles and frangible couplings measurement](#).

[Figure 3](#) shows an example of the relation between the pole, the frangible coupling and the mounting base. The pole and frangible coupling are assembled before delivery.



Note

Frangible couplings are not universal, meaning there are different models intended to be used with different sign sizes.

Figure 3: Pole, frangible coupling and mounting base

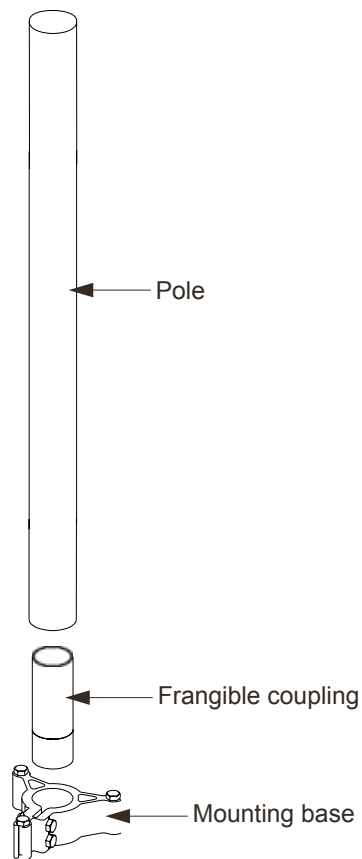

4.1.1 Tools to use

The standard tools listed below are required or recommended when installing a sign, but keep in mind that other tools may be needed depending on installation site.

- Socket set (16 mm, 17 mm, 18 mm, 19 mm) with a 15 cm or 6" extension bar
- Torx key T20 and T30
- Spanner 25 mm and 27 mm
- Small flat screwdriver to be used when installing power cable
- Spirit level

- Tape measure
- 100 mm spacers for alignment and easier installation of panel with clamps¹

Once site preparation is complete, the correct poles and frangible couplings must be identified for a sign installation.

4.1.2 External electrical connections

It is recommended to consider the routing of external electrical cables to power signs. Cable passages and junction boxes may need to be built into the foundations where signs are to be installed.

Signs are designed with one entrance point for power cable. The point is located on the bottom surface of the converter box, at the back of the sign. The cable gland at the entrance point accept cables measuring 7 to 13 mm in diameter. Connection terminal for the power cable is located next to the cable entrance, see [Figure 4](#).

To ground the sign after installation, attach a ring type crimp terminal to the ground wire and then fasten it to the back of the sign using the grounding screw. M5 head screw is located near the base of the converter box and is marked with a grounding symbol. It is also possible to ground the sign via the terminal block inside the converter box.

i Note Signs are not supplied with external wiring, as cabling requirements differ from site to site.

Figure 4: Cable entrance

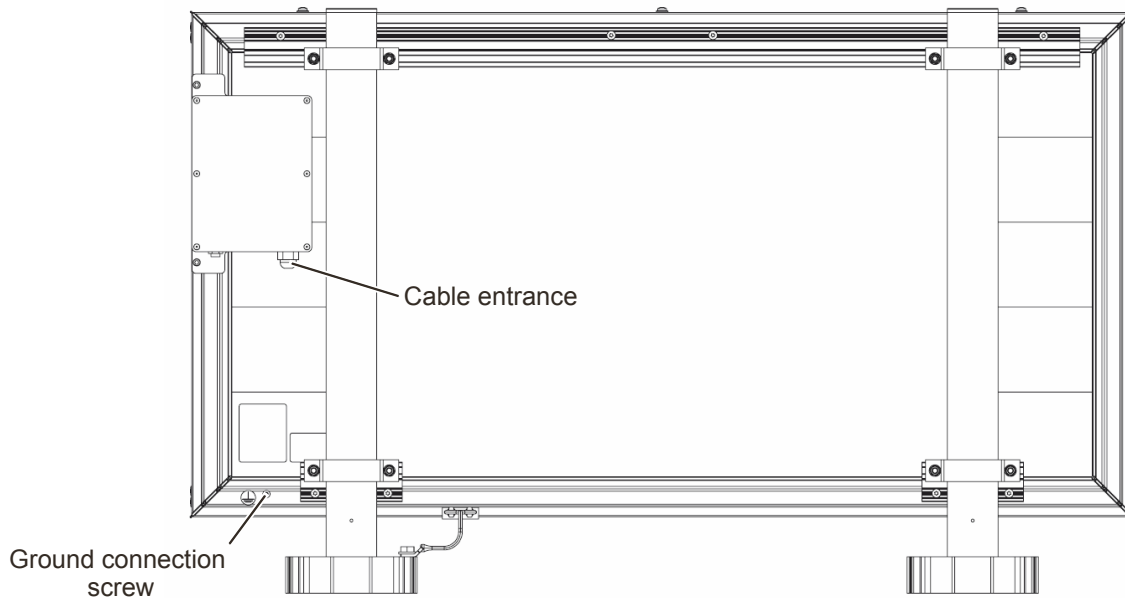

4.1.3 Mounting system

Prepare the installation site. Make sure that the correct poles and frangible couplings are used at installation, see [Poles and frangible couplings measurement](#).

¹ Only for version 4.0 and earlier.

Installation

1. Install the mounting bases and poles for the sign.
2. Center and level the upper mounting profile and attach on the poles by using U-clamps, washers, bolts and lock nut. Recommended torque: 8Nm.

Figure 5: Mounting profile on poles

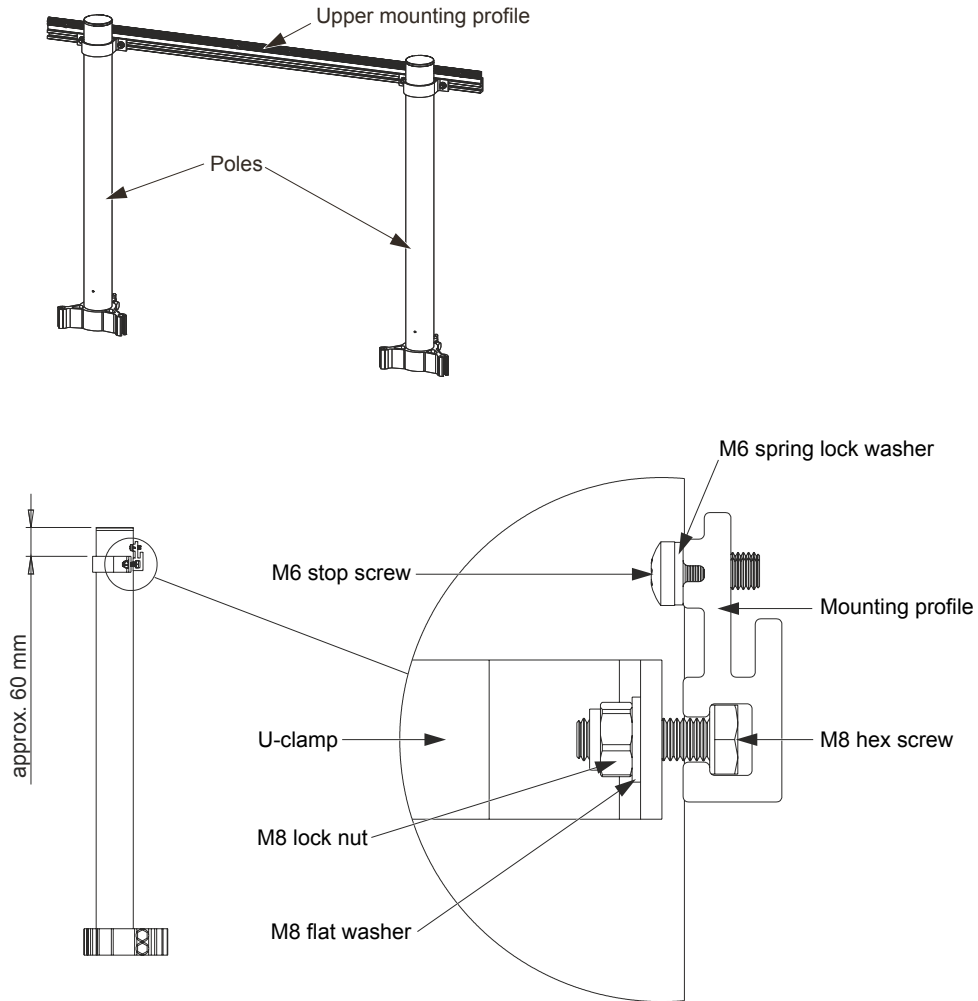

3. Hang the sign on the mounting profile. The flange of the sign match the track in the mounting profile.

Figure 6: Placement of sign on poles

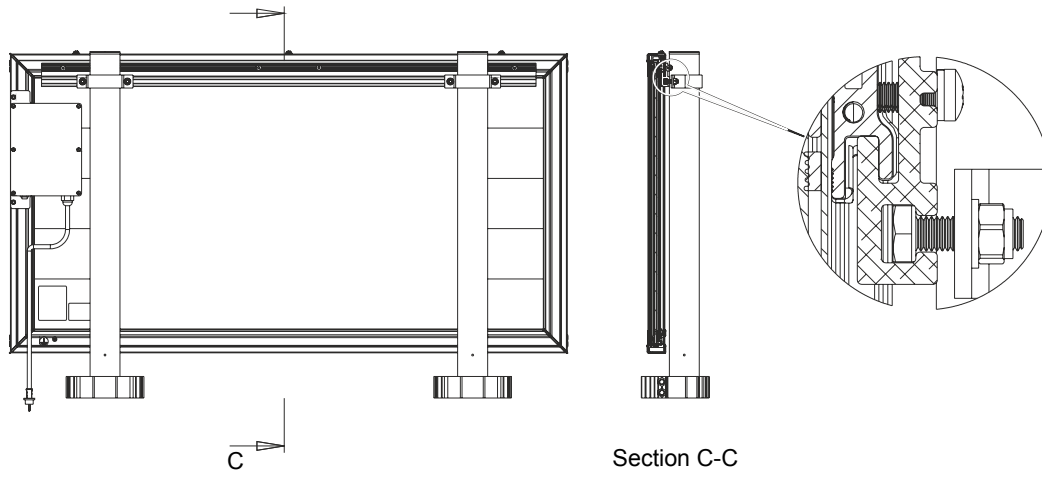

4. Mount the lower mounting profiles on the poles by using U-clamps, washers, bolts and lock nut. Recommended torque: 8Nm.

Figure 7: Placement of lower mounting profiles and clamps

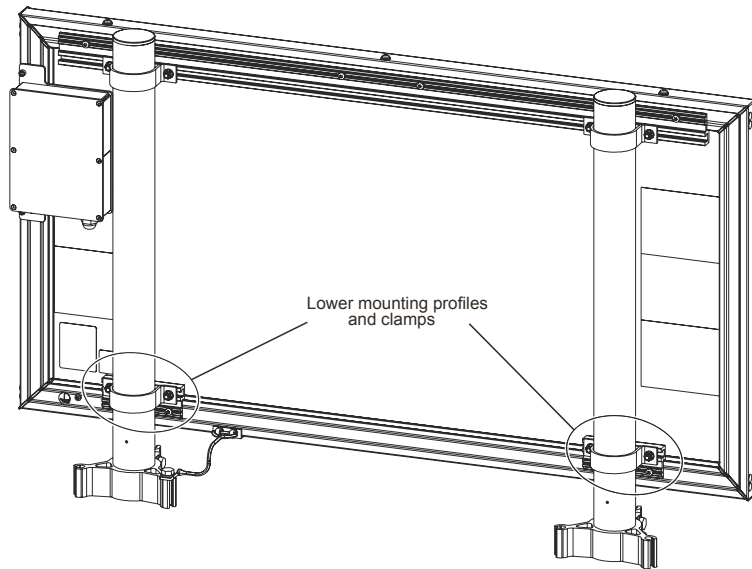

5. Fasten the stop screws on the mounting profiles, marked in Figure 8. Recommended torque: 2Nm.

Figure 8: Illustrative example of stop-screw positions, may vary depending on type and size of sign

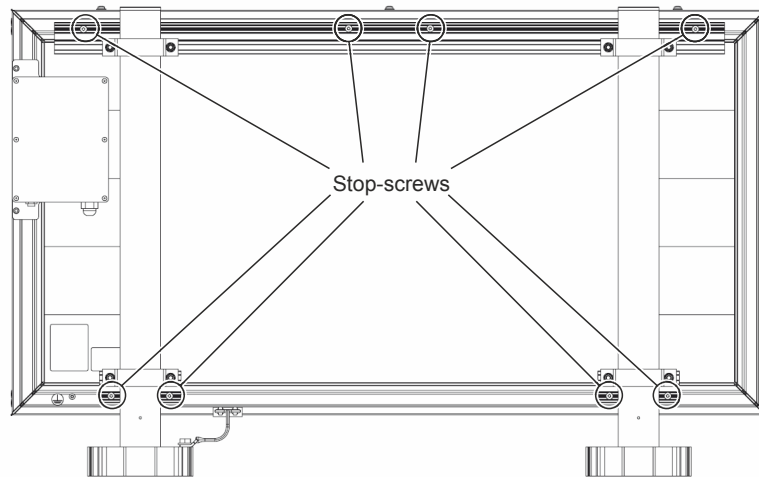

4.2 Mounting a Tether wire

4.2.1 Tether wire - without pre-drilled holes

Before you start, make sure that the sign is unpowered.

The sign should always be secured using the supplied tether wire. It is recommended to place the supplied bracket on the bottom frame, 300 mm from the edge of the sign on each side.

Tools to use

- Drill of $\varnothing 6.5$ mm
- Double-sided tape 30 × 45 mm

- Alcohol based detergent
- Cloth

Installation

1. With a alcohol based detergent, clean the lower profile surface where the bracket shall be mounted.
2. Place a thin piece of double-sided tape on the inside of the bracket.
3. Peel off the protective cover from the double-sided tape on the bracket.

Figure 9: Peel off the protective cover



4. Mount the bracket at its intended place on the lower profile.

Figure 10: Place the bracket



5. Drill the parallel holes, one side at a time, through the front and back of the lower profile using the holes of the bracket for guidance.

Figure 11: Drill holes through the profile

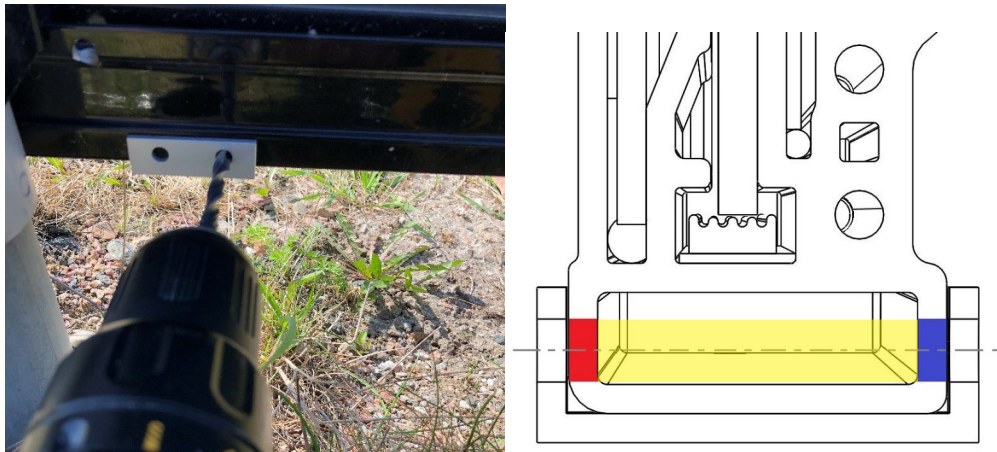

6. On the back, mount the two eye bolts with a washer between the eye bolt and bracket.

Figure 12: Mount washers and eye bolts



7. On the front, mount the washers and lock nuts.

Figure 13: Attach washers and tighten lock nuts



8. Gently tighten the lock nuts, using a wrench to keep the eye bolt fixed.
9. Fasten the tethering wire bracket to the mounting base of the pole or in the foundation.

4.2.2 Tether wire - with pre-drilled holes

The sign should always be secured using the supplied tether wire. There are two positions prepared for tether wire installation. These are located on the bottom frame and 300 mm from the edge of the sign on each side.

Choose which of the prepared tether wire locations to use based on the sign's specific installation site
Before you start, make sure that the sign is unpowered.

Tools to use

- Wrench

Installation

1. Choose which of the prepared tether wire locations to use based on the sign's specific installation site.
2. Place the bracket on the lower frame.

Figure 14: Place the bracket



3. On the back, mount the two eye bolts with a washer between the eye bolt and bracket.

Figure 15: Mount washers and eye bolts



4. On the front, mount the washers and lock nuts.

Figure 16: Mount washers and lock nuts



5. Gently tighten the lock nuts, using a wrench to keep the eye bolt fixed.
6. Fasten the tethering wire bracket to the mounting base of the pole or in the foundation.

4.3 Electrical connection

Before you start, make sure that the sign is unpowered.

Tools to use

- Torx T20
- Small flat screwdriver for electrical connection
- Spanner SW25 mm

Installation

1. Run the power cable through the cable gland.
2. Open the converter box and attach the leads to the appropriate terminal.
3. Close the converter box, make sure the gasket is intact and in place.
4. Tighten the cable gland.
5. Energize the power circuit to which the sign is connected and check for proper operation.

4.4 Bird deterrent spikes (Optional)

Bird deterrent spikes for mounting on a sign is optional.

Tools to use

- Snips, or appropriate tool, to cut the bird spike in sections
- Outdoor adhesive
- Cleaning equipment

Installation

1. Cut the bird spike sections into appropriate lengths.
2. If needed, make cut-outs or holes for the fasteners on the top-surface.
3. Clean the top-surface of the sign.
4. Attach the bird spike sections using an outdoor adhesive.

Notice

Do not use fasteners when attaching the bird spikes as it can effect the weather resistance of the sign.

Figure 17: Bird spike

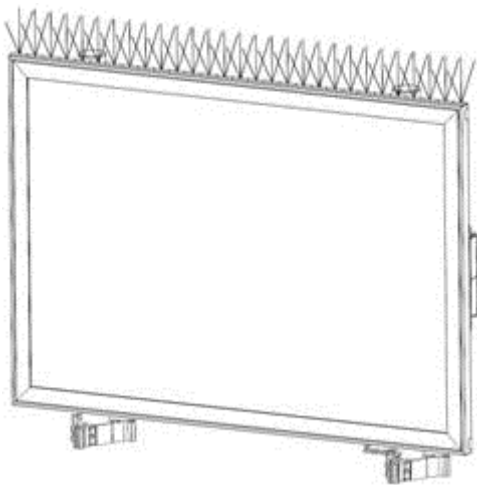

4.5 Reflective tape

The signs are delivered with two reflective tapes, one for each side of the back of the sign. The reflective tapes are placed at the outer parts on the back of the sign.

Figure 18: Reflective tape area

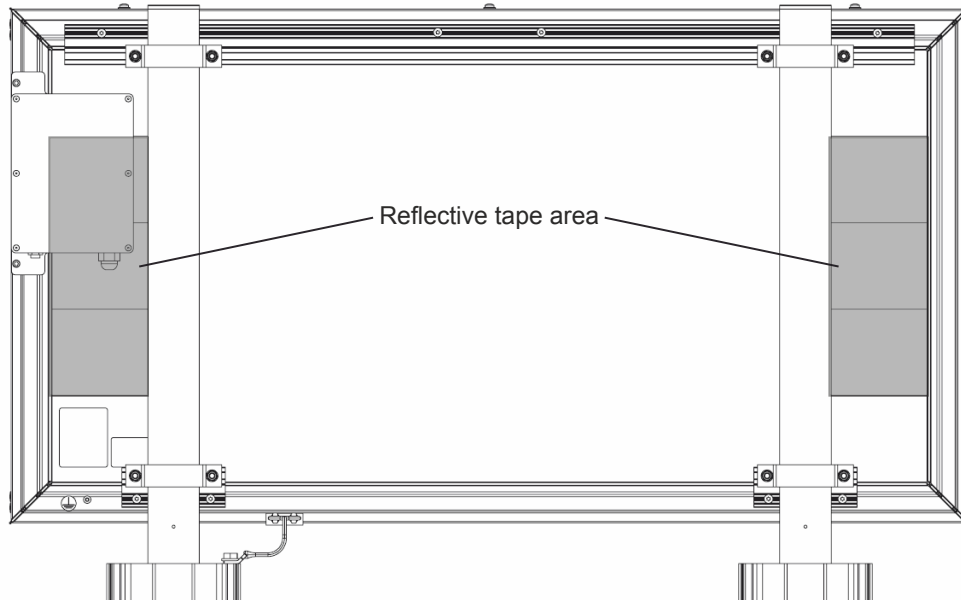

4.6 Gate Sign

The gate sign, Airfield Stand Identification Sign (ASIS), is designed for various mounting positions. The sign is delivered with two mounting rails to enable site mounting.

Install the sign on the desired location using the mounting rails together with T-bolts and Rail-nuts. Acquire a clamp of appropriate size compared to the mounting pole. Chose T-bolts/Rail-nut designed for the dimension of the mounting rails, which is 41/41/2.5.



Note

Do not lift in the electronics box.

Installation

1. Run the power cable through the cable gland.
2. Open the electronics box and attach the leads to the appropriate terminal contacts.
3. Tighten the cable gland.
4. Energize the power circuit to which the sign is connected and check for proper operation.

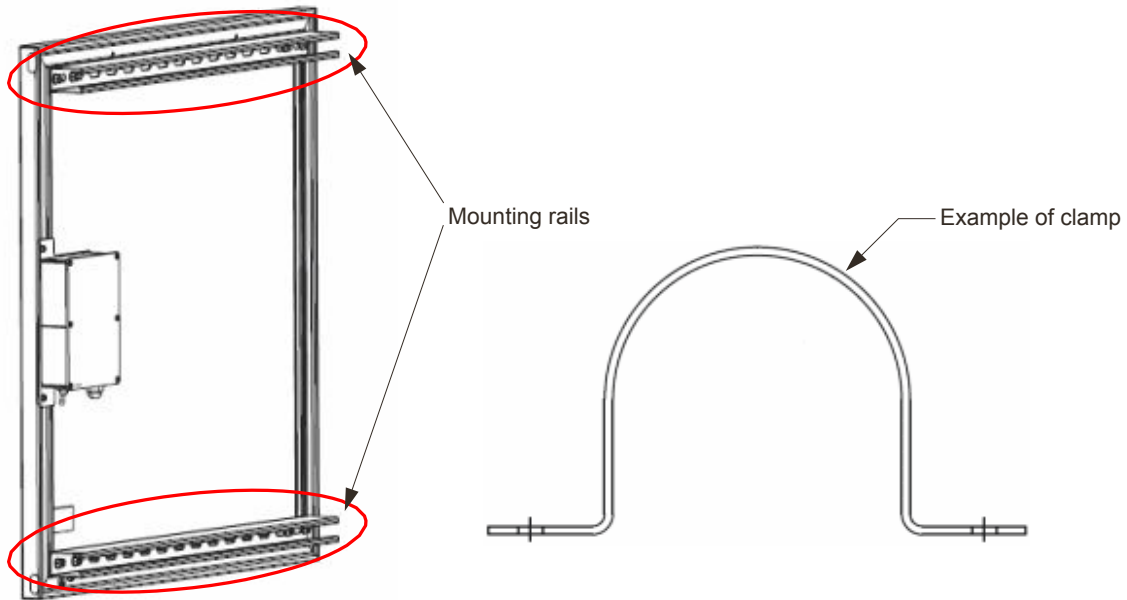

5.0 Operation

The sign units are usually connected to the airfield power system and made available to other airport power control systems if required, for example ADB SAFEGATE RELIANCE Airfield Lighting Control Systems (ALCS).

The sign units are easy to read in daylight, in darkness, and with limited visibility. The high readability is a result of a high quality front panel, a unique painting technique and customized light distribution inside the sign. The combination of robust aluminum construction, state-of-the-art electronics, and outstanding lifetime of the light sources, makes the sign uniquely versatile and suitable for airport environments around the world.

Figure 19: Sign front example



6.0 Maintenance

The sign units require minimal maintenance. A routine inspection is recommended to be performed once a year with the following checks:

- Damage to sign front, housing and exposed cabling
- Check drainage and remove any connected dirt
- Check the condition of the gaskets, sealing washers and LED-cutout tape. Replace if needed.
- Tighten by hand all fasteners holding the sign securely in place on the clamps and in the base
- Power off the sign then check the terminal contacts to make sure that the power cable wiring is secured

The following sections describes how to perform various maintenance tasks.

6.1 Replace a front panel

Before you start, make sure that the sign is turned off and not energized.

Note
For SafeLED Sign version 1.0 to 2.5, see [Replace a LED-strip version 1.0 to 2.5](#).

Figure 20: Front panel overview

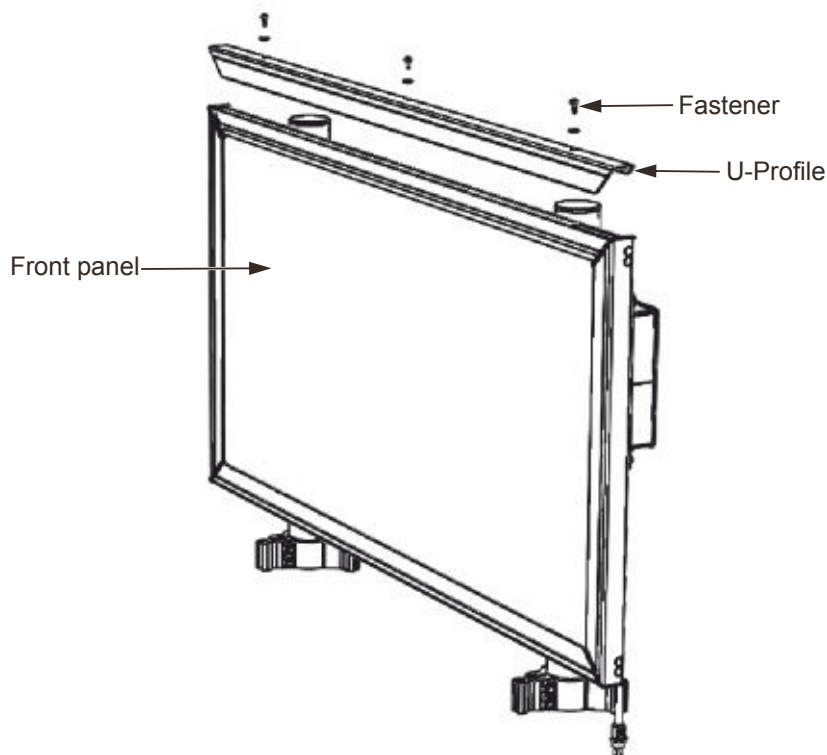

1. Remove the fasteners holding the U-profile on top of the sign.
2. Remove the U-profile.
3. Remove the front panel by lifting it straight up.
4. Remove the plastic protection layer off the new front panel and insert the panel from the top.
5. Place and align the top U-profile on the sign.



Note

Make sure that the corner gaskets are in correct positions after mounting.

6. Gently tighten the fasteners to firmly fixate the U-profile.

6.2 Replace a LED-strip

Before you start, make sure that the sign is turned off and not energized.



Note

For SafeLED Sign version 1.0 to 2.0, see [Replace a front panel version 1.0 to 2.0](#).

Figure 21: Front panel overview

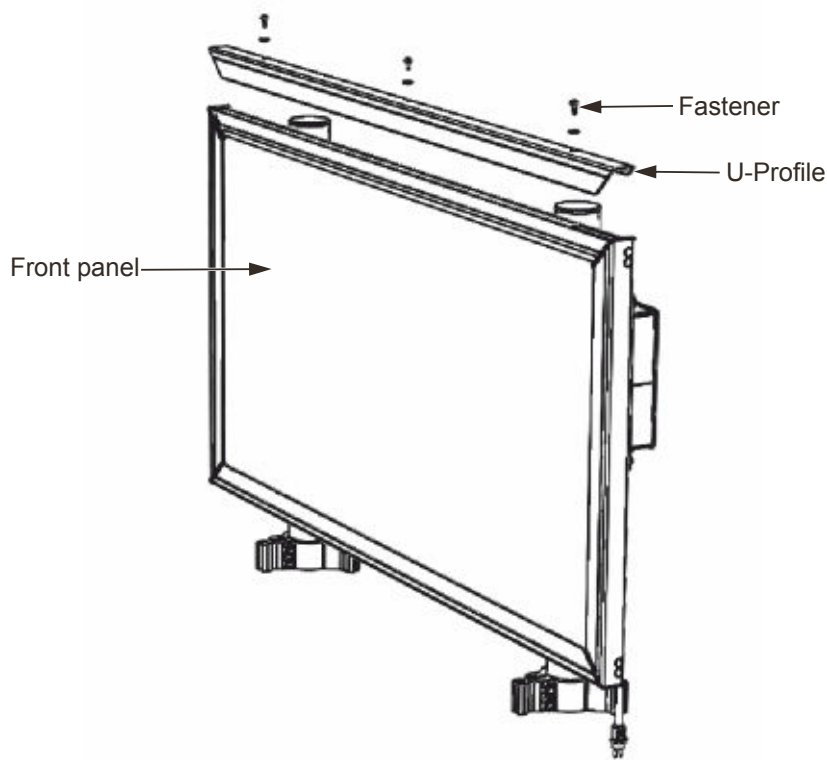

1. Remove the fasteners at the top of the sign.
2. Remove the U-profile, the LED-strip with cables is then visible through a cut-out on top of the profile, [Figure 22](#).
In later versions, remove the sealing-tape covering the cut-out.



Note

Be careful not to damage the connector or to cut yourself on any sharp edge in the cut-out.

Figure 22: Frame-profile cut-out

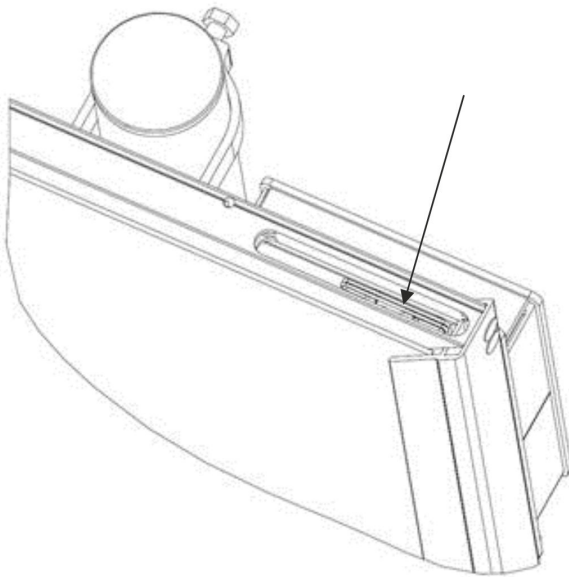

3. Disconnect the LED-cable.
4. Lift the revealed LED-strip end up, which slightly bends the LED-strip, [Figure 23](#).
5. Pull out the LED-strip through the cut-out, [Figure 23](#).

Figure 23: Pull out LED-strip



6. Insert a new LED-strip by carefully sliding it into its proper position, [Figure 24](#).

Figure 24: Insert LED-strip



7. Connect the LED-cables and place the connector on top of the LED-strip.
8. Place a water- and weatherproof sealing-tape covering the cut-out and progressing down the sides.
9. Place and align the top U-profile on the sign.



Note

Make sure that the corner gaskets are in correct positions after mounting.

10. Gently tighten the fasteners to firmly fixate the U-profile.

6.3 Replace an adapter card

Before you start, make sure that the sign is turned off and not energized.

1. On the Electronic box, remove the six countersunk screws (A), then lift off the lid, [Figure 25](#).

Figure 25: Electronic box lid

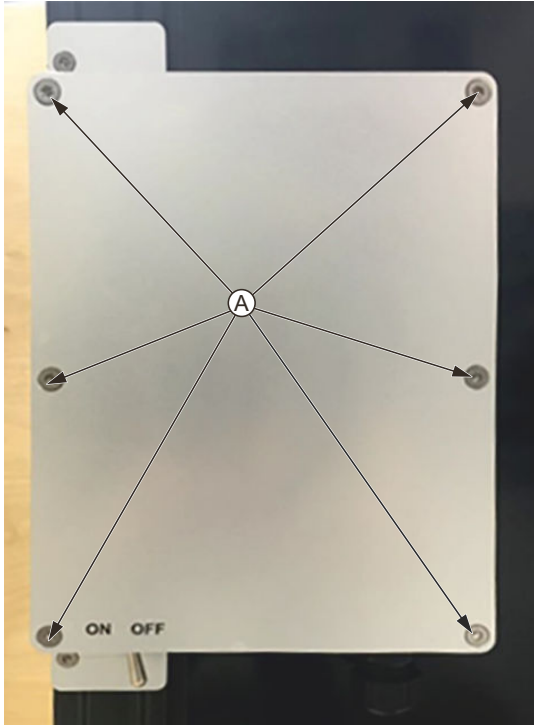

2. Release the two small screws (B), then remove the red and black wire attached to the LED strip. See [Figure 26](#).

Figure 26: Remove the wires

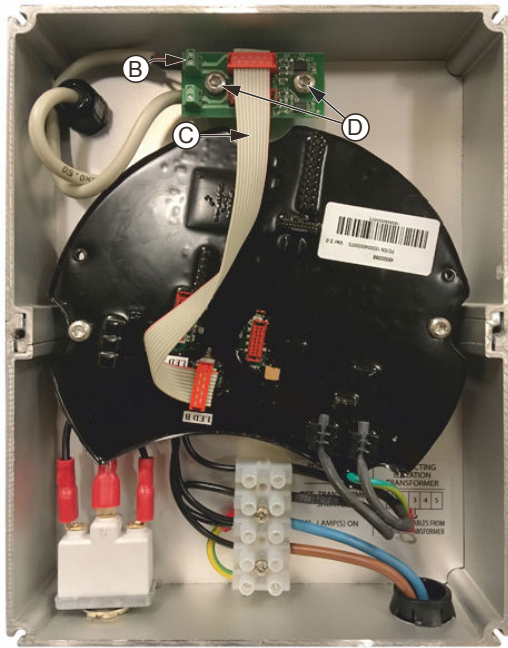

3. Remove the grey LED cable (C) from the adapter card. See [Figure 26](#).
4. Remove the two screws (D) holding the adapter card, then replace the adapter card with a new one. See [Figure 26](#).



CAUTION

Use the adapter card included with the LED strip spare part kit, this since the parameters are specified for the particular version of the LED strip and length and height of the sign.

5. Place the new adapter card in its position and attach it with the two screws (D), [Figure 26](#).
6. Attach the grey LED cable (C), with the colored wire to the right, to the B-channel on the converter. See [Figure 26](#).



Note

Make sure that the B-channel on the converter is used to power the LED-strip.

7. Attach the wires (B) to the adapter card, black to (-) and red to (+). See [Figure 26](#).
8. Close and attach the lid to the box, fastening with the six countersunk screws (A). See [Figure 25](#).

6.4 Replace a converter

Before you start, make sure that the sign is turned off and not energized.

1. On the Electronic box, remove the six screws (A), then lift off the lid, see [Figure 27](#).

Figure 27: Electronic box

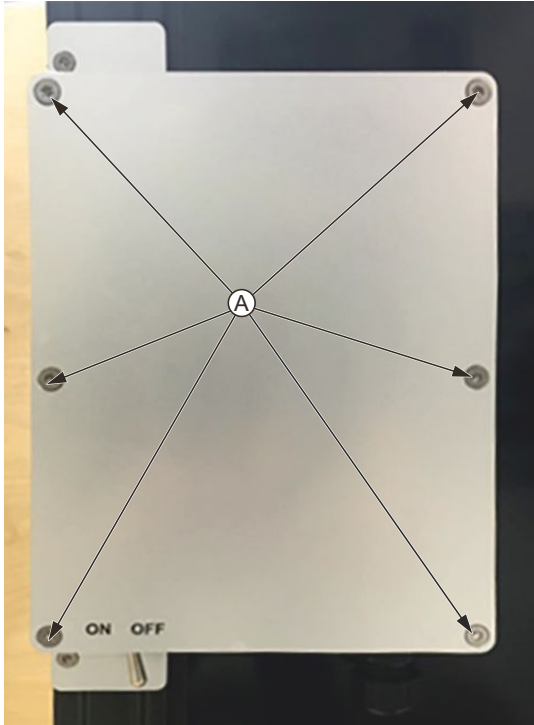

2. Release the upper right two screws (B) on the terminal block, then remove the two black wires connected to the converter. See [Figure 28](#).

Figure 28: Converter

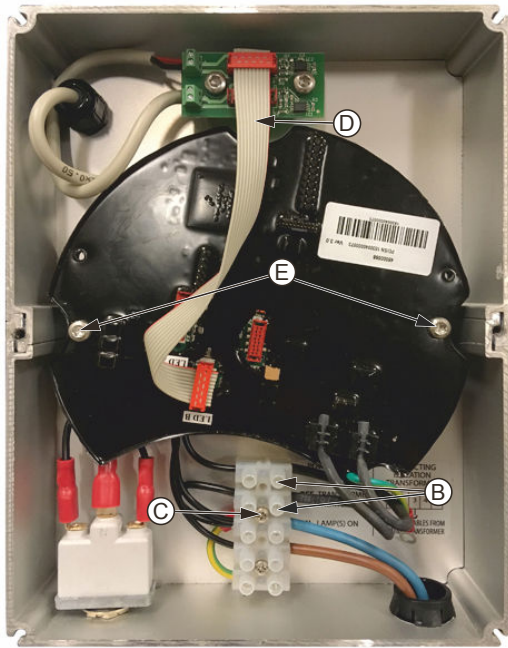

3. Remove the center screw (C) holding the terminal block to release the converter earthing wire. See [Figure 28](#).
4. Remove the grey LED cable (D) from the adapter card. See [Figure 28](#).
5. Remove the two screws (E) attaching the converter to the electronics box. See [Figure 28](#).
6. Remove the old converter from the electronics box, then attach the new one using the two screws (E). See [Figure 28](#).
7. Attach the earthing cables under the terminal block using the center screw (C). See [Figure 28](#).
8. Attach the two black wires from the converter to the two upper right screws (B) of the terminal block. See [Figure 28](#).
9. Attach the grey LED cable (D), with the colored wires to the right, to the adapter card and the B-channel. See [Figure 28](#).
10. Close and attach the lid to the box using the six countersunk screws (A). See [Figure 27](#).

6.5 Replace a damaged power cable

Figure 29: Electronic box overview

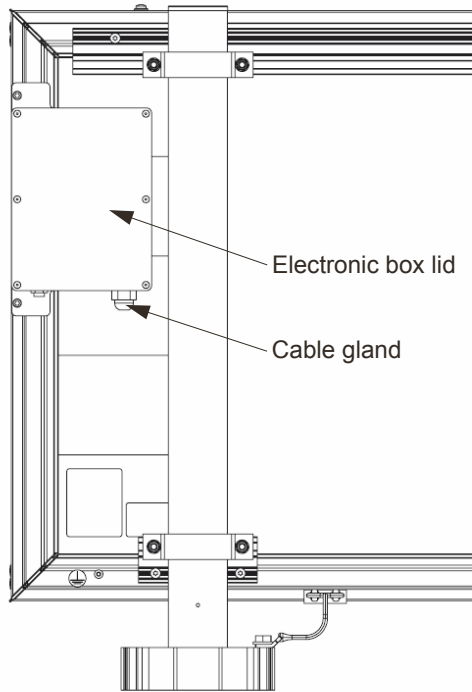

1. Disconnect the sign from the transformer.
2. On the Electronic box, remove the six screws (A), then lift off the lid. See [Figure 30](#).

Figure 30: Remove the lid

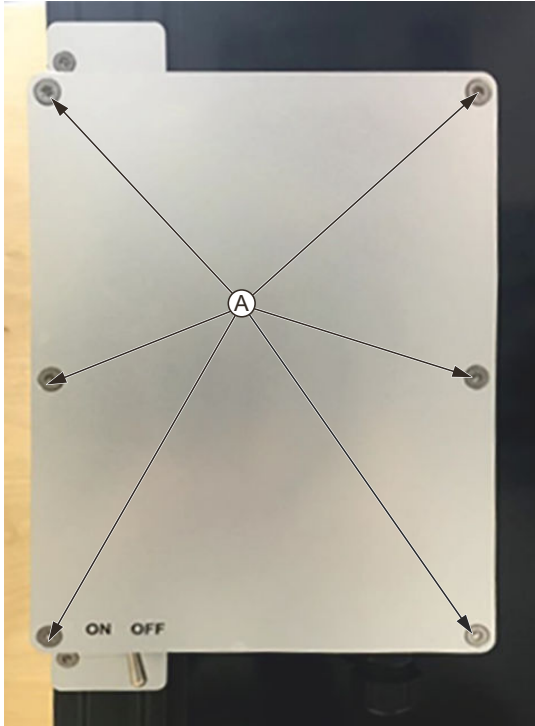

3. Remove the screws holding the cables from the terminal block (B) inside the converter box. See [Figure 31](#).

Figure 31: Terminal block

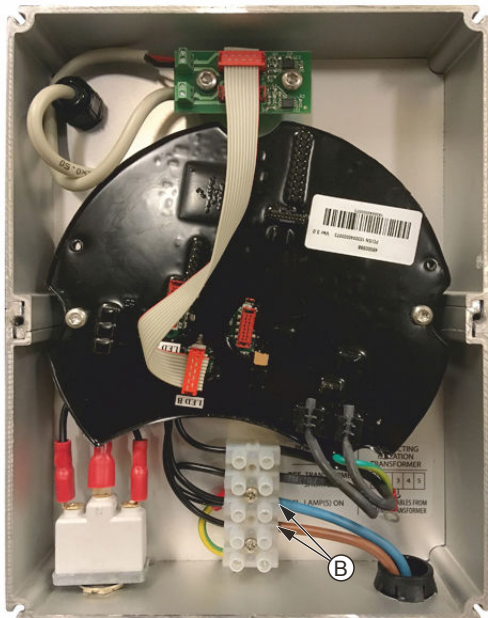

4. Loosen the cable gland, thereby releasing the cable.
5. Pull the open end of the new cable through the cable gland.

6. Connect the cable to the terminal block (B) inside the converter box (see [Internal Wiring - Series Powered LED](#)).
7. Tighten the cable gland.
8. Close and attach the lid to the box using the six countersunk screws (A). See [Figure 29](#).

6.6 Replace a frangible coupling

Figure 32: Frangible coupling overview

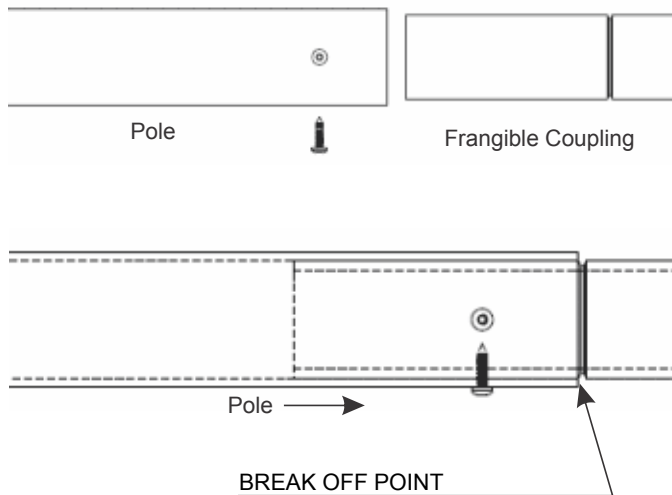

1. Remove the sign from the poles.
2. Remove the frangible coupling from the pole by loosening the two screws at the base. Save the screws to the new coupling.
3. Insert the new frangible coupling in the pole with the break-off point located at the end of the pole.
4. Drill new holes, $\varnothing 4.5$ mm, in the frangible coupling, using the holes in the pole for guidance, then fasten with the two screws.
5. Insert the pole with the attached frangible coupling in the base.
6. Repeat this procedure on the remaining poles.



Note

A frangible coupling will break when hit with sufficient force. If one frangible coupling breaks all remaining frangible couplings must be replaced.

7.0 Troubleshooting

Troubleshooting can solve the most common issues that can occur on the sign. If an issue cannot be solved, contact Support, see [SUPPORT](#).

Before you start make sure you have read and understand the [Safety instructions](#).

The following sections describes how to perform troubleshooting.

7.1 The sign does not light up correctly

Issue	Possible reason	Possible action
Only parts or sections of the sign do not light up.	Damaged LED-strip.	Change LED-strip to a spare.
No part of the sign lights up.	An issue with the input power.	Check using a clamp meter that the input power to the sign is correct. If there is no input power some possible reasons are damaged power cable on the sign or an issue with the transformer.
	An issue with the converter box.	Verify that the converter switch is set to ON . Verify, with the cable disconnected from the power, that the wiring in the converter box is the same as in the internal wiring diagrams series and voltage and that the cables are securely installed in the terminal block.
The upper right corner is much darker than the rest of the sign.	No contact between the LED-strip and the light panel due to for example that the LED-cable is clamped between the panel and strip.	Remove the U-profile. Look at the LED-strip inside the cut-out and remove anything preventing contact between the LED-strip and the light panel.
	Damaged LED-strip.	Change LED-strip to a spare.

7.2 The sign has mechanical issues

Issue	Possible reason	Possible action
The front panel looks bad or message is hard to read.	The front panel is dirty.	Remove the front panel. and clean it using a mild soap.
	Light panel is dirty.	Remove the front panel. Check if the transparent panel behind it is dirty. If so, clean it gently using a mild glass cleaner.
	Front panel is damaged.	Replace the front panel with a spare.
	Collected water inside the sign	Remove any collected water on the front panel or the light barrier by using a soft cloth. Verify that the drainages are not blocked by dirt. Verify that all gaskets are in good condition, including the sealing washers and LED-cutout tape ¹ . Verify that all screws are fastened firmly in place.
The sign is skew after a collision.	A non-permanent deformation.	Remove the sign from its poles and let the sign recover for ~1 hour.
	Fasteners for the frame have loosened.	Re-tighten the frame fasteners by hand. These are located under the plastic domes on the sign sides.

Notes

¹ Tape is only for SafeLED version 5.0.

7.3 Internal Wiring - Series Powered LED

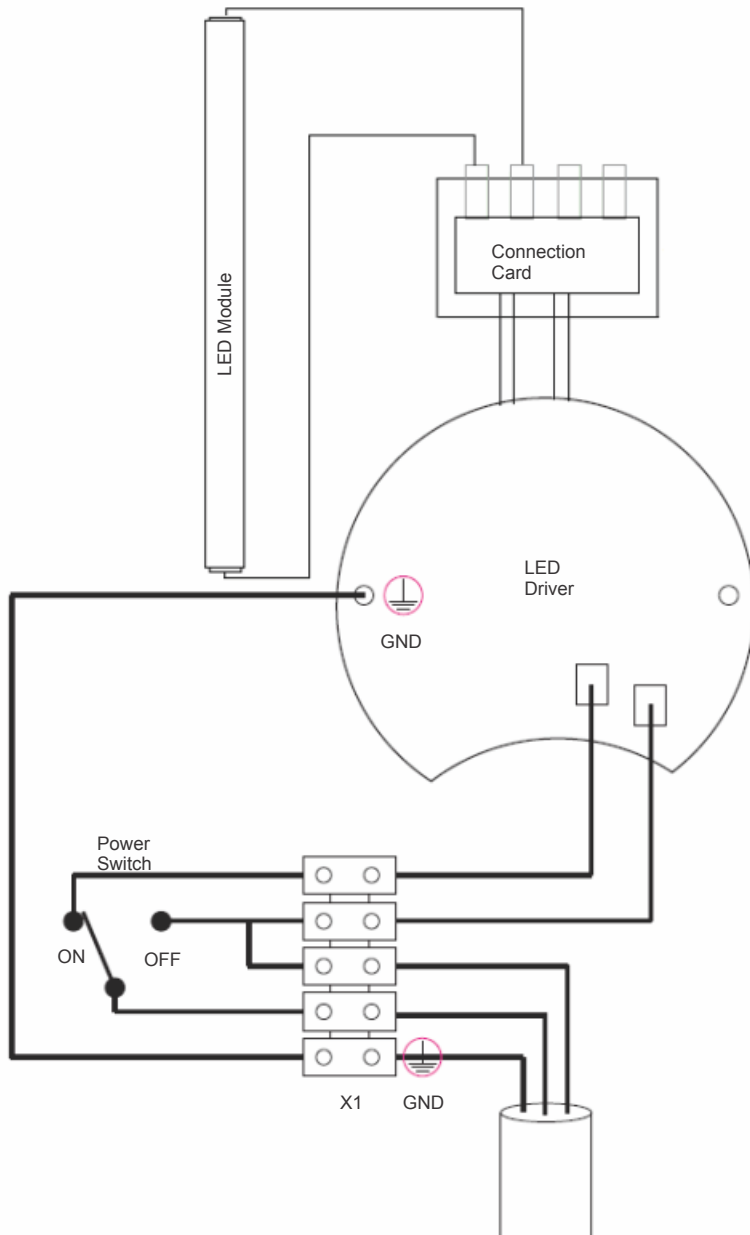

7.4 Internal Wiring - Voltage Powered LED

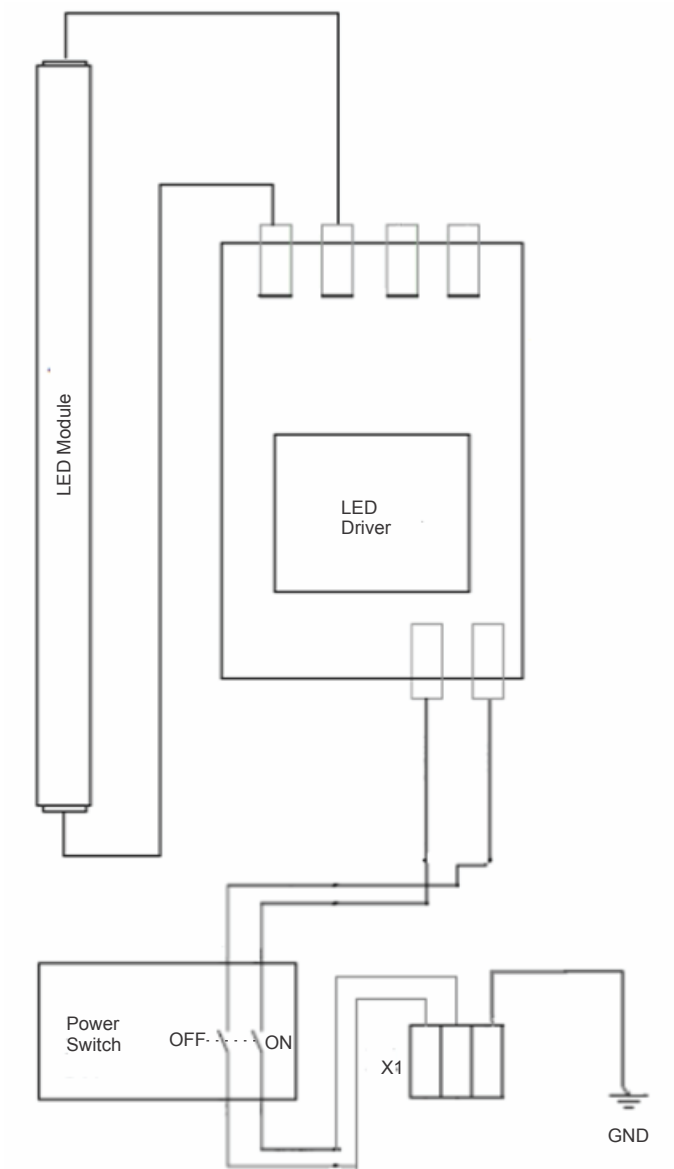

8.0 Spare Parts

8.1 SafeLED Sign

In order to select correct spare parts, make sure to check the version number of sign. The version number is found on the product label on the back of the sign. This list covers both Guidance Signs and Gate Signs.

Figure 33: Sign back

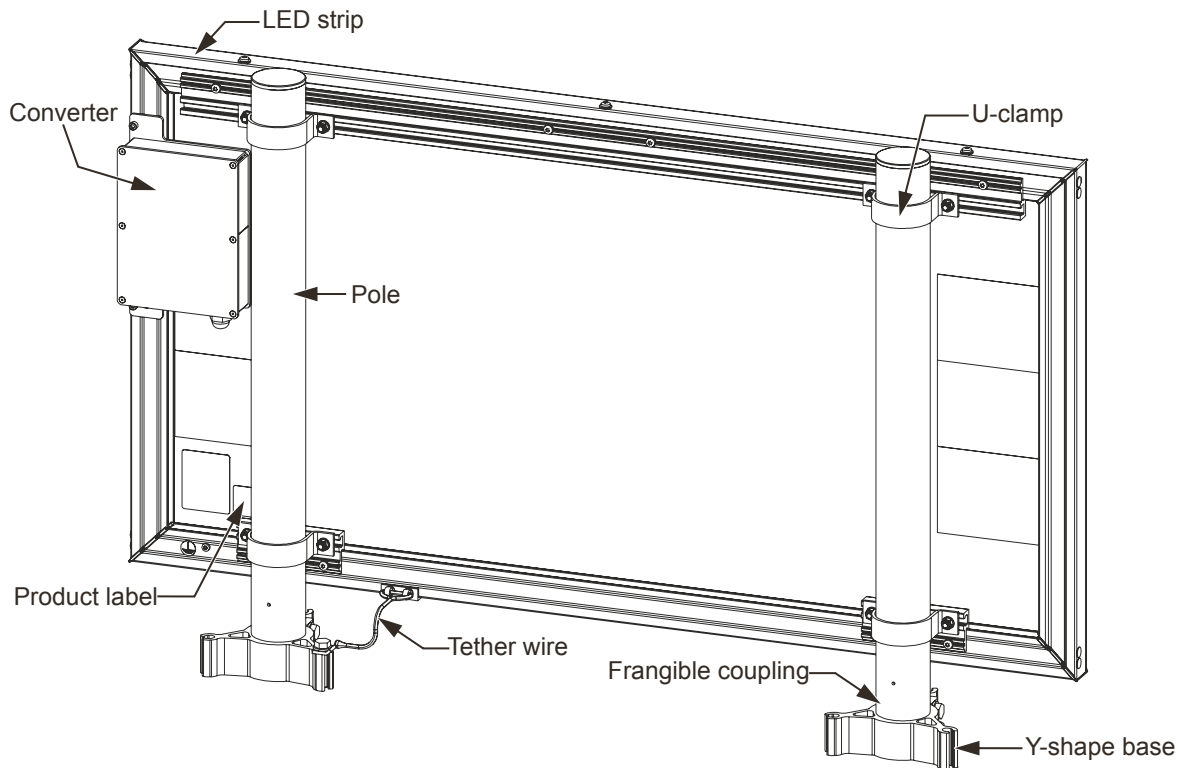

Table 7: Installation material

Description	Order code
3 bolt, Y-shape base	SG13993
Pole for 700 mm high signs	SG13994
Pole for 900 mm high signs	SG13995
Clamp, including bolt and nut, 1 pcs ¹	SG13996
U-clamp, including bolt and nut, 10 pcs ²	SG25836
Sealing kit, including corner gaskets, sealing washers and bolts for top profile, 100 pcs	SG25837
Safety tether M6	SG25755
T-bolt M10	SEL1121832

Notes

¹ SafeLED Sign version 1 to 4

² SafeLED Sign version 5

Table 8: Converter

Description	Order code
Converter LED 6.6A	SG17951
Converter LED 230V	SG18028
180 mm LED cable (between converter and adapter card), package of 10 pcs	SGE.SP18650
Photocell Gate Sign	SG24504

Frangible Couplings for wind load requirement ICAO 322 km/h and FAA Mode 2

Table 9: Sign height 700 mm

Sign size (mm)	For 3 bolt, Y-shape, mounting base	For Pre-cast foundation
1150	SG13981 (1.8)	SG15180 (1.8)
1300	SG13981 (1.8)	SG15180 (1.8)
1600	SG13981 (1.8)	SG15180 (1.8)
1800	SG13982 (2.2)	SG15180 (2.2)
2100	SG13981 (1.8)	SG15180 (1.8)
2500	SG13981 (1.8)	SG15180 (1.8)
2650	SG13980 (1.6)	SG15180 (1.6)
3000	SG13981 (1.8)	SG15180 (1.8)

Table 10: Sign height 900 mm

Sign size (mm)	For 3 bolt, Y-shape, mounting base	For Pre-cast foundation
1150	SG13983 (2.6)	SG15180 (2.6)
1300	SG13983 (2.6)	SG15180 (2.6)
1600	SG13983 (2.6)	SG15180 (2.6)
1800	SG13984 (3.1)	SG15180 (3.1)
2100	SG13982 (2.2)	SG15180 (2.2)
2500	SG13983 (2.6)	SG15180 (2.6)
2650	SG13983 (2.6)	SG15180 (2.6)
3000	SG13983 (2.6)	SG15180 (2.6)



Note

When replacement frangible couplings are delivered, they need to be mounted in existing poles. Do this by inserting the end of the frangible coupling that is 150 mm from the break-off point, into the pole until the end of the pole is centered over the break off point of the frangible coupling. Fasten the two together using the self-threading screws that were supplied with the original assembly.

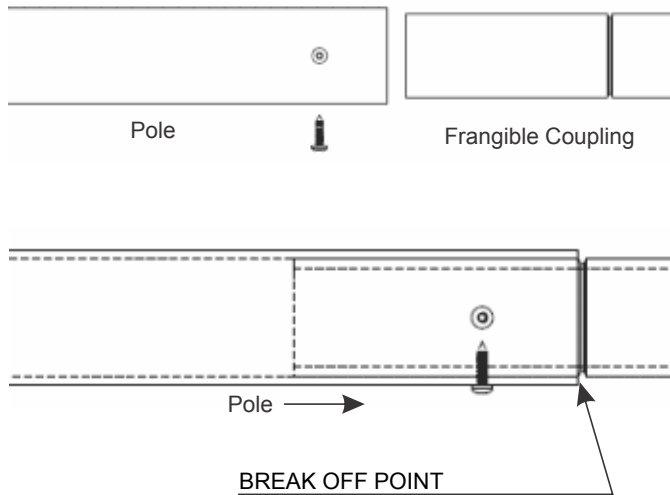

Frangible Couplings for wind load requirement ICAO 480 km/h and FAA Mode 3

Table 11: Sign height 700 mm

Sign size (mm)	For 3 bolt, Y-shape, mounting base	For Pre-cast foundation
1150	SG18697 (3.8)	SG15180 (3.8)
1300	SG18697 (3.8)	SG15180 (3.8)
1600	SG13984 (3.1)	SG15180 (3.1)
1800	SG13984 (3.1)	SG15180 (3.1)
2100	SG18697 (3.8)	SG15180 (3.8)
2500	SG13984 (3.1)	SG15180 (3.1)
2650	SG13984 (3.1)	SG15180 (3.1)
3000	SG18697 (3.8)	SG15180 (3.8)

Table 12: Sign height 900 mm

Sign size (mm)	For 3 bolt, Y-shape, mounting base	For Pre-cast foundation
1150	SG18697 (3.8)	SG15180 (3.8)
1300	SG18697 (3.8)	SG15180 (3.8)
1600	SG13984 (3.1)	SG15180 (3.1)
1800	SG13984 (3.1)	SG15180 (3.1)
2100	SG18697 (3.8)	SG15180 (3.8)
2500	SG18697 (3.8)	SG15180 (3.8)
2650	SG18697 (3.8)	SG15180 (3.8)
3000	SG18697 (3.8)	SG15180 (3.8)

For more instructions regarding replacement of frangible couplings, see the [note](#) in Frangible Couplings for wind load requirement ICAO 322 km/h.

LED modules for SafeLED Sign version 2 to 5

Table 13: Sign height 700 mm

Sign size (mm)	One led strip + one adapter card
1150	SG19119
1300	SG19120
1600	SG19121
1800	SG19122
2100	SG19123
2500	SG19124
2650	SG19125
3000	SG19126

Table 14: Sign height 900 mm

Sign size (mm)	One led strip + one adapter card
1150	SG19127
1300	SG19128
1600	SG19129
1800	SG19130
2100	SG19131
2500	SG19132
2650	SG19133
3000	SG19134

Table 15: Gate sign

Sign size (mm)	One led strip
900 x 900	SG17949
1200 x 1200	SG17950

LED modules for SafeLED Sign version 1.0 and 1.1

Table 16: Sign height 700 mm

Sign size (mm)	SafeLED Sign version 1.0 Dual led strips + one adapter card	SafeLED Sign version 1.1 One led strip + one adapter card
1150	SG24836	SG19119
1300	SG19267	SG19120
1600	SG19268	SG19121
1800	SG19269	SG19122
2100	SG24837	SG19123

Table 16: Sign height 700 mm (continued)

Sign size (mm)	SafeLED Sign version 1.0 Dual led strips + one adapter card	SafeLED Sign version 1.1 One led strip + one adapter card
2500	SG19270	SG19124
2650	SG19271	SG19125
3000	SG19272	SG19126

Table 17: Sign height 900 mm

Sign size (mm)	SafeLED Sign version 1.0 Dual led strips + one adapter card	SafeLED Sign version 1.1 One led strip + one adapter card
1150	SG24836	SG24836
1300	SG19267	SG19267
1600	SG19268	SG19268
1800	SG19269	SG19269
2100	SG24837	SG24837
2500	SG19270	SG19270
2650	SG19271	SG19271
3000	SG19272	SG19272

Note
Airfield Sign

Broken or damaged LED strip on SafeLED Sign v.1.0 - 2.0: LED strip(s), adapter card and converter needs to be replaced. But if converter replacement has been done once (after April 2016), only LED strip(s) and adapter card needs to be replaced.

SafeLED Sign version v 1.0-1.1 have two LED strips. Both must be replaced at the same time even if only one is broken. For traceability and correct assessment of needed spare parts please keep record of all spare part replacements.

Broken or damaged LED strip SafeLED Sign v.3.0 or later: LED strip incl adapter card needs to be replaced.

If converter is broken on any of the versions: Replace with new converter according to spare part list above.

Gate Sign

Broken or damaged LED strip: Only LED strip need to be replaced.

CAUTION

It is important to use the provided LED strips and the adapter card included in the LED module spare part kit since it is specific for the version and dimension of the sign.

Front panels

Table 18: Sign height 700 mm

Sign size (mm)	Order code
1150	SG17923
1300	SG17924
1600	SG17925
1800	SG17926
2100	SG17927
2500	SG17928
2650	SG17929
3000	SG17930

Table 19: Sign height 900 mm

Sign size (mm)	Order code
1150	SG17931
1300	SG17932
1600	SG17933
1800	SG17934
2100	SG17935
2500	SG17936
2650	SG17937
3000	SG17938

Table 20: Gate sign

Sign size (mm)	Order code
900 x 900	SG17939
1200 x 1200	SG17940

9.0 SUPPORT

Our experienced engineers are available for support and service at all times, 24 hour/7 days a week. They are part of a dynamic organization making sure the entire ADB SAFEGATE is committed to minimal disturbance for airport operations.

ADB SAFEGATE Support

Live Technical Support - Americas

If at any time you have a question or concern about your product, just contact ADB SAFEGATE's technical service department. Trained in all areas of system issues, troubleshooting, quality control and technical assistance, our highly experienced Technical support specialists are available 24 hours a day, seven days a week to provide assistance over the phone.

ADB SAFEGATE **Americas Technical Service & Support (US & Canada): +1-800-545-4157**

ADB SAFEGATE Americas Technical Service & Support (International): +1-614-861-1304

During regular business hours, you can also Chat with a Service Technician. We look forward to working with you!

Before You Call

When you have an airfield lighting or system control system problem it is our goal to support airfield maintenance staff as quickly as possible. To support this effort we ask that you have the following information ready before calling.

- The *airport code*
- If not with an airport, then company name (prefer customer id number)
- Contact phone number and email address
- Product with part number preferable or product number
- Have you reviewed the product's manual and troubleshooting guide
- Do you have a *True RMS* meter available (and any other necessary tools)
- Be located with the product ready to troubleshoot

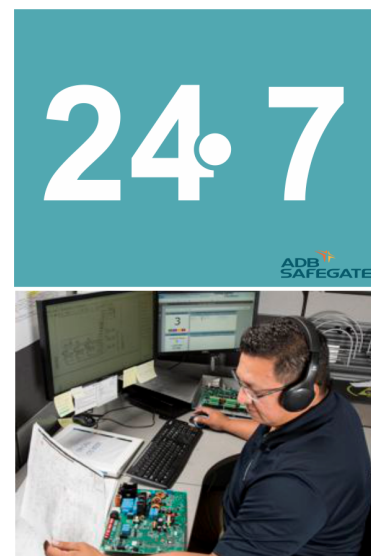

Note

For more information, see www.adbsafegate.com, or contact ADB SAFEGATE Support via email at support@adbsafegate.com or

Brussels: +32 2 722 17 11

Rest of Europe: +46 (0) 40 699 17 40

Americas: +1 614 861 1304. Press 3 for technical service or press 4 for sales support.

China: +86 (10) 8476 0106

9.1 ADB SAFEGATE website

The ADB SAFEGATE website, www.adbsafegate.com, offers information regarding our airport solutions, products, company, news, links, downloads, references, contacts and more.

9.2 Recycling

9.2.1 Local authority recycling

The disposal of ADB SAFEGATE products is to be made at an applicable collection point for the recycling of electrical and electronic equipment. The correct disposal of equipment prevents any potential negative consequences for the environment and human health, which could otherwise be caused by inappropriate waste handling. The recycling of materials helps to conserve natural resources. For more detailed information about recycling of products, contact your local authority city office.

9.2.2 ADB SAFEGATE recycling

ADB SAFEGATE is fully committed to environmentally-conscious manufacturing with strict monitoring of our own processes as well as supplier components and sub-contractor operations. ADB SAFEGATE offers a recycling program for our products to all customers worldwide, whether or not the products were sold within the EU.

ADB SAFEGATE products and/or specific electrical and electronic component parts which are fully removed/separated from any customer equipment and returned will be accepted for our recycling program.

All items returned must be clearly labelled as follows:

- For *ROHS/WEEE* Recycling
- Sender contact information (Name, Business Address, Phone number).
- Main Unit Serial Number.

ADB SAFEGATE will continue to monitor and update according for any future requirements for *EU directives* as and when *EU member states* implement new *regulations* and or *amendments*. It is our aim to maintain our *compliance plan* and assist our customers.

A.1 Mounting before version 5.0

Prepare the installation site. Make sure that the correct poles and frangible couplings are used at installation, see [Poles and frangible couplings measurement](#).

The poles may need to be adjusted to line up with the mounting flanges on the sign and a deformed clamp, for example after maintenance, shall always be replaced.

Figure 34: SafeLED sign front

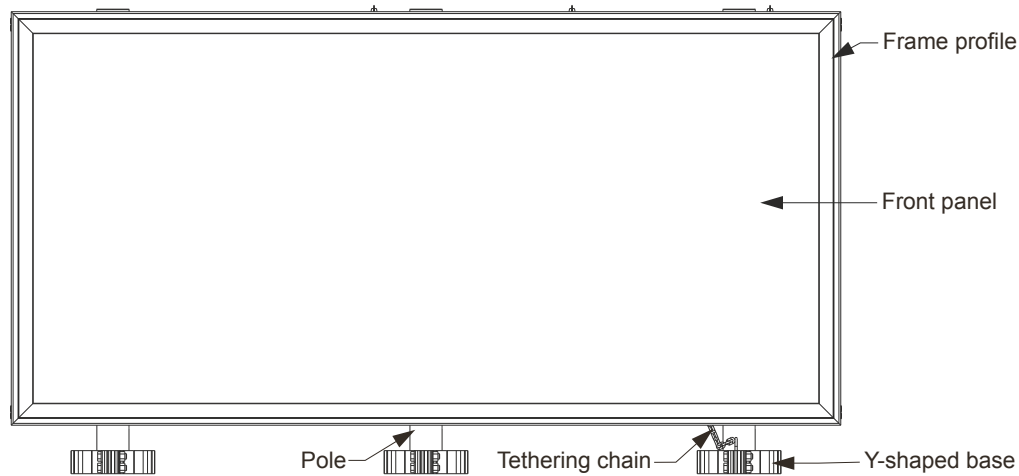
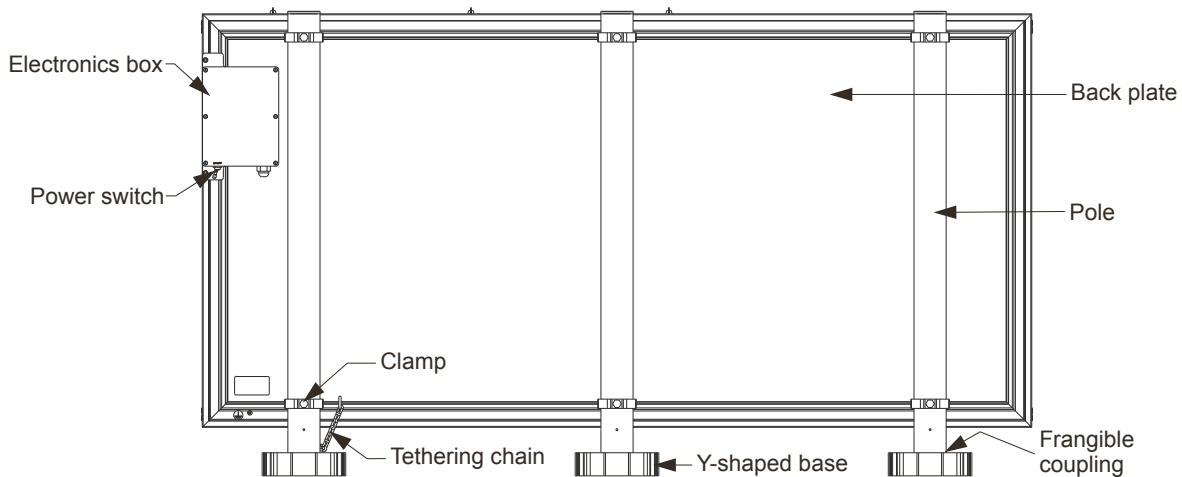

Figure 35: SafeLED sign back



1. Install the mounting bases and poles for the sign.
2. Mount the lower clamps, notches facing down and approximately halfway up each pole, then hand-tighten the set screws.

- Place 100 mm spacers on the foundations next to each pole, see [Figure 36](#).

Figure 36: Spacer marked in red

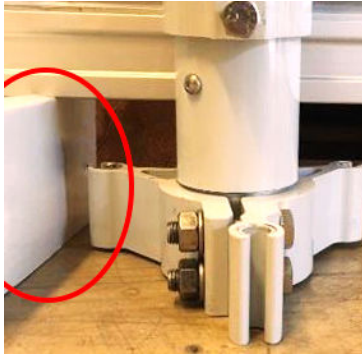

Note

Do not lift in the electronics box!

- Mount a upper clamp on one of the poles, with notches facing up, and hand-tighten the set screw.
- Place the sign on the spacers and position the upper clamp to align with the mounting flange at the back of the sign.
- Mount clamps on the remaining poles using a spirit level, or other leveling device, to align the upper clamps at the same height as the first clamp. Make sure the clamps are in a horizontal position with notches face-up, see [Figure 37](#).

Figure 37: To the left a correct installation of a clamp

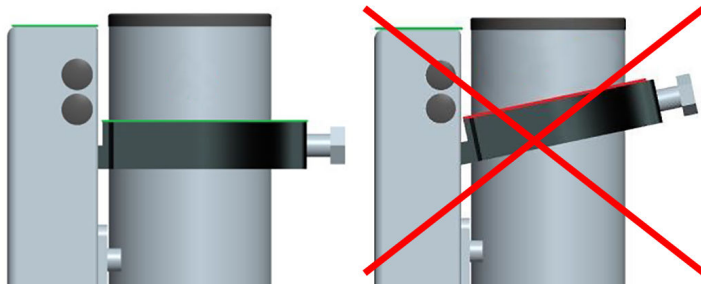

- Tighten the screws on the upper clamps to fixate the sign.
- Slide each of the lower clamps downward, until they mate with the mounting flanges, then tighten each set screw until the bracket slightly shapes to the contours of the pole. When correctly installed a torque of 15Nm can be applied.



Note

Fixate the clamps horizontally and do not over-tighten the screws.

- Fasten the tethering wire eye bolt at the bottom of the sign profile.
For information about installation of tethering wire, see [Tether wire - without pre-drilled holes](#)

10. Fasten the tethering wire bracket to the mounting base of the pole or in the foundation.
11. Finish the assembly by tightening all fasteners holding the base plate against the installation surface, see [Figure 38](#).

Figure 38: Correct assembly of sign

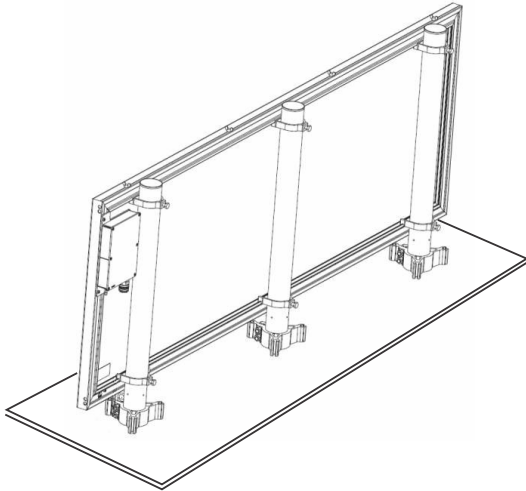

A.2 Replace a front panel version 1.0 to 2.0

Before you start, make sure that the sign is turned off and not energized.

1. Remove the sign from the poles.
2. Carefully remove the fasteners at each side of the sign, then loosen the set screws at the back of the top profile.
3. Gently lift the right edge of the top profile and disconnect the LED-cable.
4. Remove the front panel by lifting it straight up.

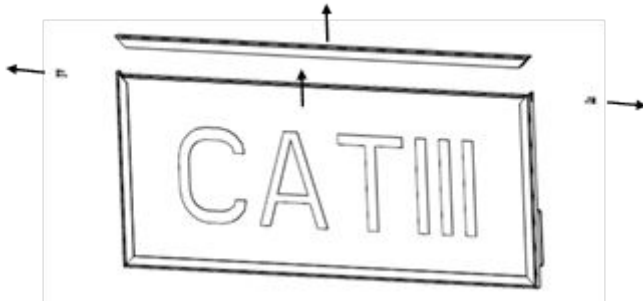

5. Remove the plastic protection layer off the new front panel and insert the panel by sliding it into the frame straight from above.
6. Put the top profile, including LEDs, back onto the sign and attach the LED cable to the connector.

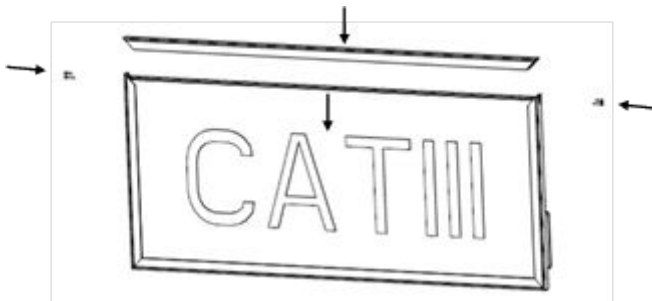

7. Tighten the fasteners on the sides and at the top of the profile.
8. Put the sign back onto the poles, see [Mounting before version 5.0](#).

A.3 Replace a LED-strip version 1.0 to 2.5

Before you start, make sure that the sign is turned off and not energized.

1. Remove the sign from the poles.
2. By hand, carefully remove the fasteners at each side of the sign.
3. Gently lift the right edge of the top profile, disconnect the LED-cable and remove the top profile.

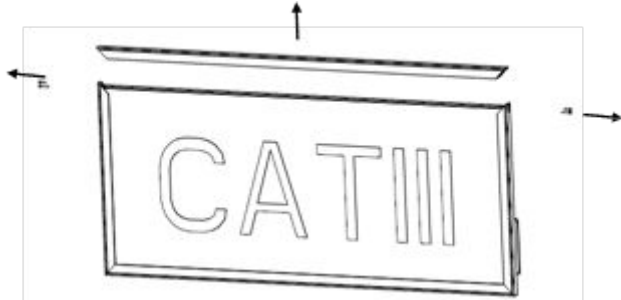

4. Remove the old LED-strip by sliding it out the profile.
5. Insert the new LED-strip by sliding it into the profile.



6. Put the top-profile, with the new LEDs, back onto the sign and attach the LED-cable to the connector.
7. Tighten the fasteners on the side and back of the top-profile.



A.4 Tethering chain

The tethering chain is equipped with two carabiner, one at each end.

1. Place one of the carabiner in the slot in the Y-shaped base (1) closest to the electronics box. Place it with one of the screws in the base running through the carabiner.

Figure 39: Tethering chain

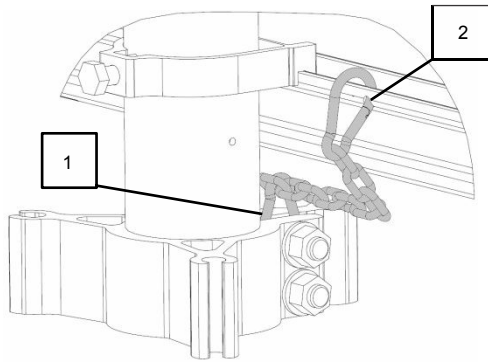

i Note

If a carabiner with a large diameter is used there is a possibility that the carabiner won't fit in the slot in the base. If this is the case, attach the carabiner together with a large washer to one of the anchor bolts instead.

2. The other carabiner should be placed in the hole in the flange on the bottom profile (2).



Powering Your Airport Performance from Approach to Departure

adbsafegate.com

Copyright © ADB SAFEGATE, all rights reserved

