

Airfield Lighting

Spare Part List

12" Uni-/Bidirectional High-Intensity Inset Light
(IDM 5672, IDM 5761)

- Bidirectional Taxiway Centre Line
- Unidirectional Taxiway Centre Line



IDM 5761

IDM 5672



Note: *This page is blank for convenient double-sided printing.*

SPARE PART LIST
12" UNI-/BIDIRECTIONAL HIGH-INTENSITY INSET LIGHT
(IDM 5672, IDM 5761)

This document includes a list of spare parts with exploded view examples.

Note: Contact Safegate Group for assistance with ordering spare parts.

Description	No.	Quantity	Code	Note
Top cover (IDM 5761)	1	0 or 1 *	10541	
Top cover straight sections (IDM 5672)		0 or 1 *	10490	N, S only
Gasket	2	1 or 2 *	10229	
Prism Narrow beam Before and after curves Wide beam	3	1 or 2 *	10486	N version only
			10816	S version only W version only
Prism protection plate	4	1 or 2 *	10485	
Prism fastening plate	5	1 or 2 *	10484	
O-ring gasket Ø219,3x5,7	6	1	10227	
Optics assembly plate "TOP"	7	1	10481	
Terminal ECT.2P	8	1 or 2 *	11743	
Sleeve	10	6 or 11 *	10232	
Insulation rubber 318-928	11	6 or 11 *	11567	
Lamp holder	12	1 or 2 *	10478	48W only
Lamp 48W 6,6A ø50mm	13	1 or 2 *	11882	ø 4 mm connectors
Lamp fastener	14	1 or 2 *	10477	48W only
Pin, fixed	15	1 or 2 *	10483	
Pin, captive	16	1 or 2 *	10482	
Coil spring SPEC D21500	17	2 or 4 *	10092	
C-ring DIN 6799-4 A2	18	2 or 4 *	10097	
Inner cover	19	1	10222	1 cable
Fastening plate, inner cover	20	3	10221	
O-ring gasket Ø6x2	21	1	11815	
Valve assembly	22	1	10235	Inc. needle and metal cap
Cable gland AGRO1005.91M6, Viton	23	2	10061	
Secondary cable 400 mm 2x1,5 mm ²	24	1	11628	vulcanised, PTFE
Washer ø4mm DIN 9021, A4	25	3 or 5 *	12021	
Slot screw M4x12 DIN 84, A4	26	3	11940	
Cross slot screw M4x16 DIN 7500C, A4	27	3 or 5 *	10098	
Allen screw M6x16 DIN 912, A4	28	4 or 8 *	10021	
Spring washer ø 6 mm DIN 127, A4	29	4 or 8 *	11946	
Slot screw M4x20 DIN 84, A4	30	1 or 2 *	11941	
Nut M4 DIN 934, A4	31	1 or 2 *	11807	
Spring washer ø4mm DIN 127, A4	32	1 or 2 *	11944	
Rivet ø4x12,5	33	3 or 6 *	11895	
Cross slot screw M4x12 DIN 7500 M, A4	34	6	12008	
Colour filter support ø50 mm	35	1 or 2 *	10822	48W only
Note: * Item is an alternative option for the light structure. For more information, see FIGURE 1.				

Description	No.	Quantity	Code	Note
Colour filter ø50 mm, green ø50 mm, yellow ø50 mm, red	36	1 or 2 *	10807 10809 10808	48W only
Optics assembly plate "TCL C"	37	1	10799	C only
Gasket	38	2	10806	C only
Prism, curves	39	2	10815	C only
Prism protection plate	40	2	10814	C only
Prism fastening plate	41	2	10824	C only
Top cover curved sections	42	1	10817	C only
Note: * Item is an alternative option for the light structure. For more information, see FIGURE 1.				

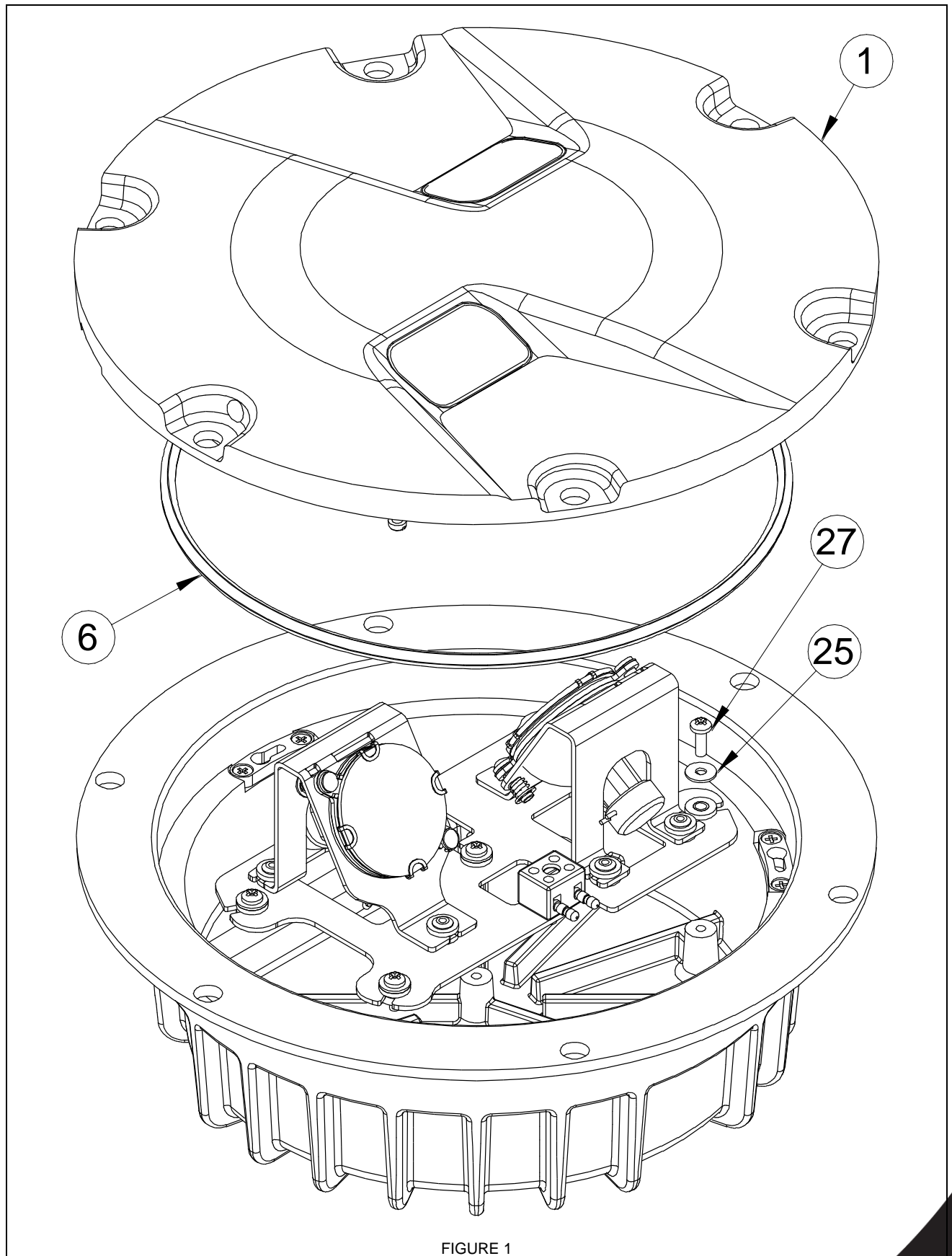

FIGURE 1

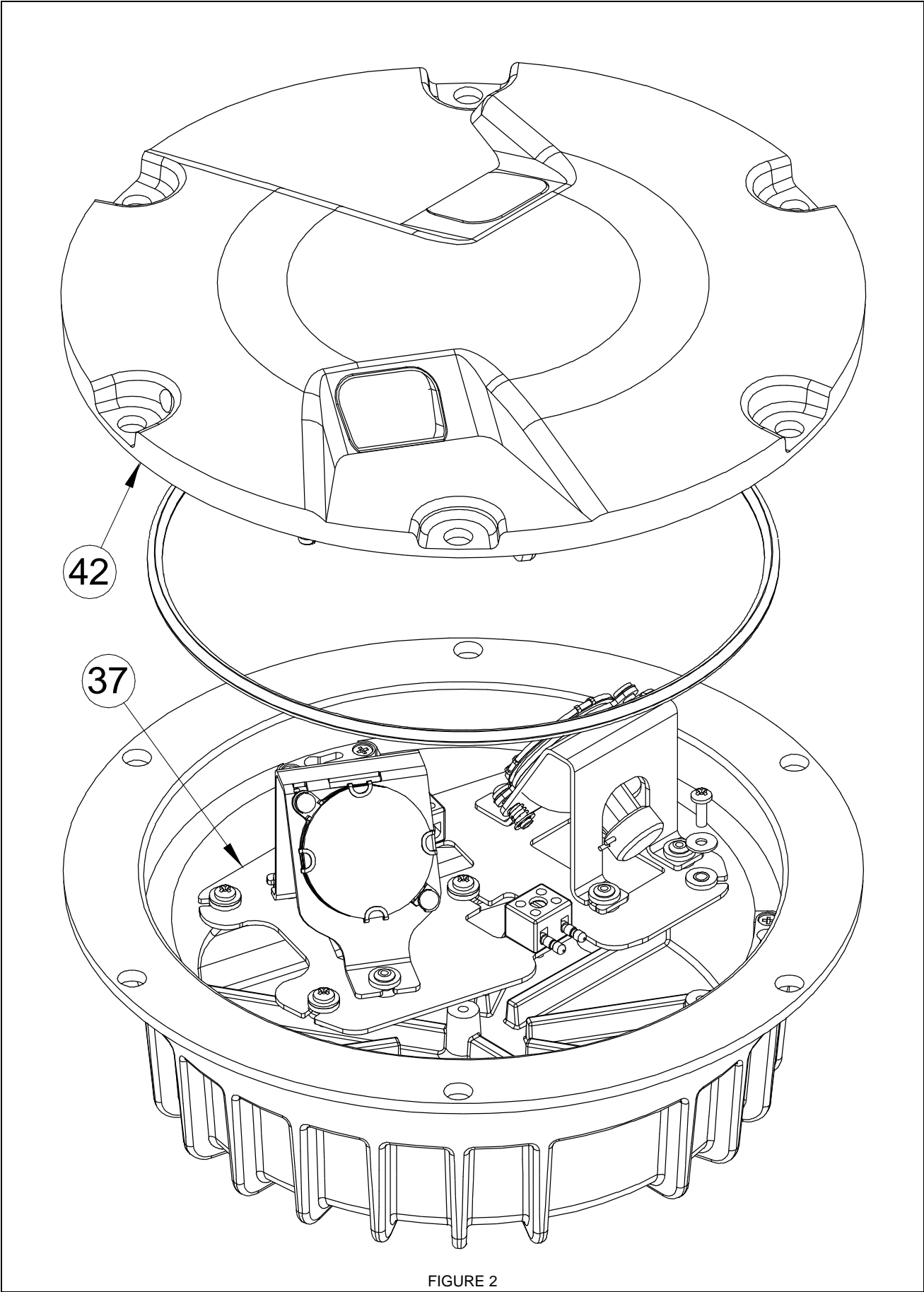
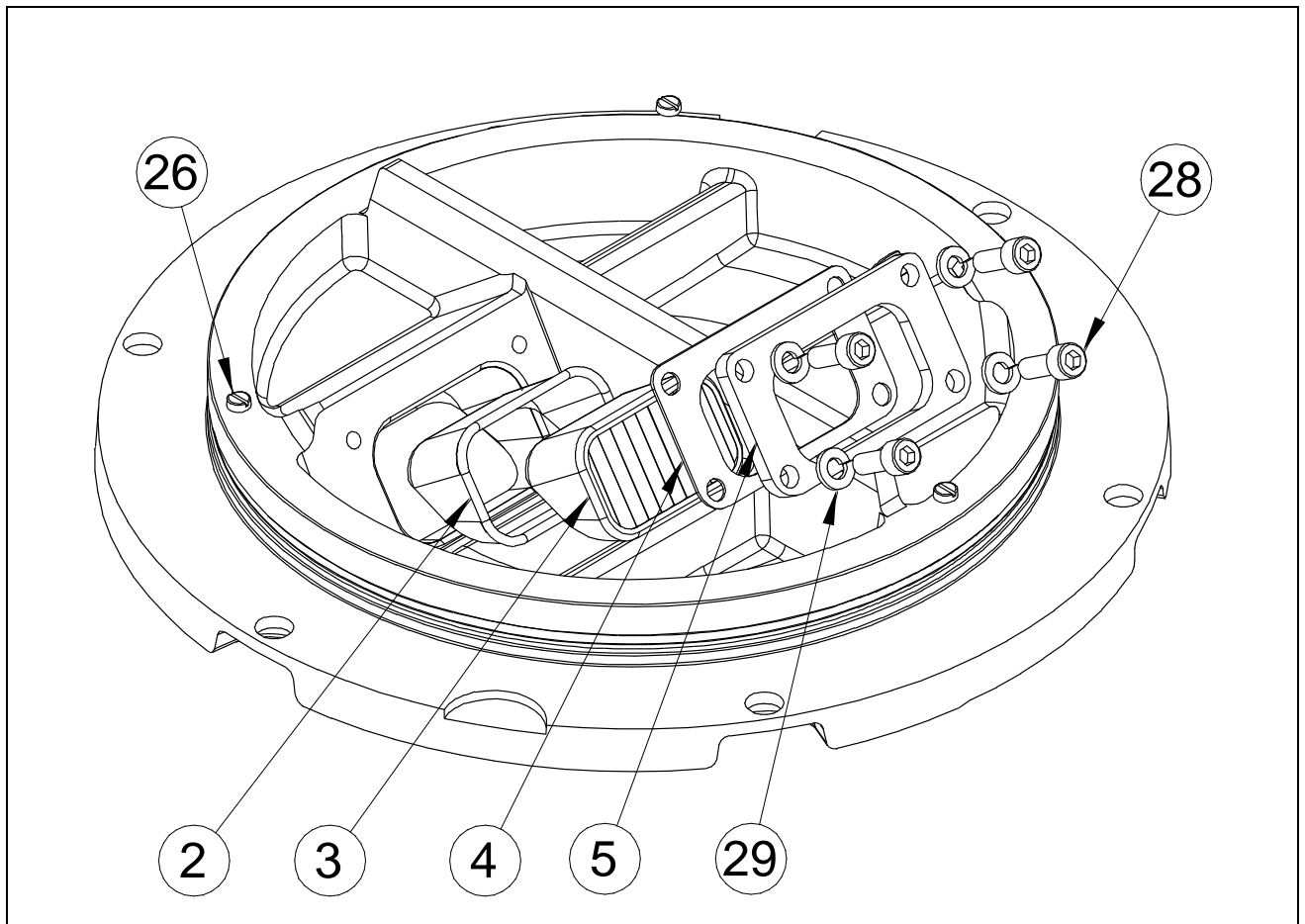
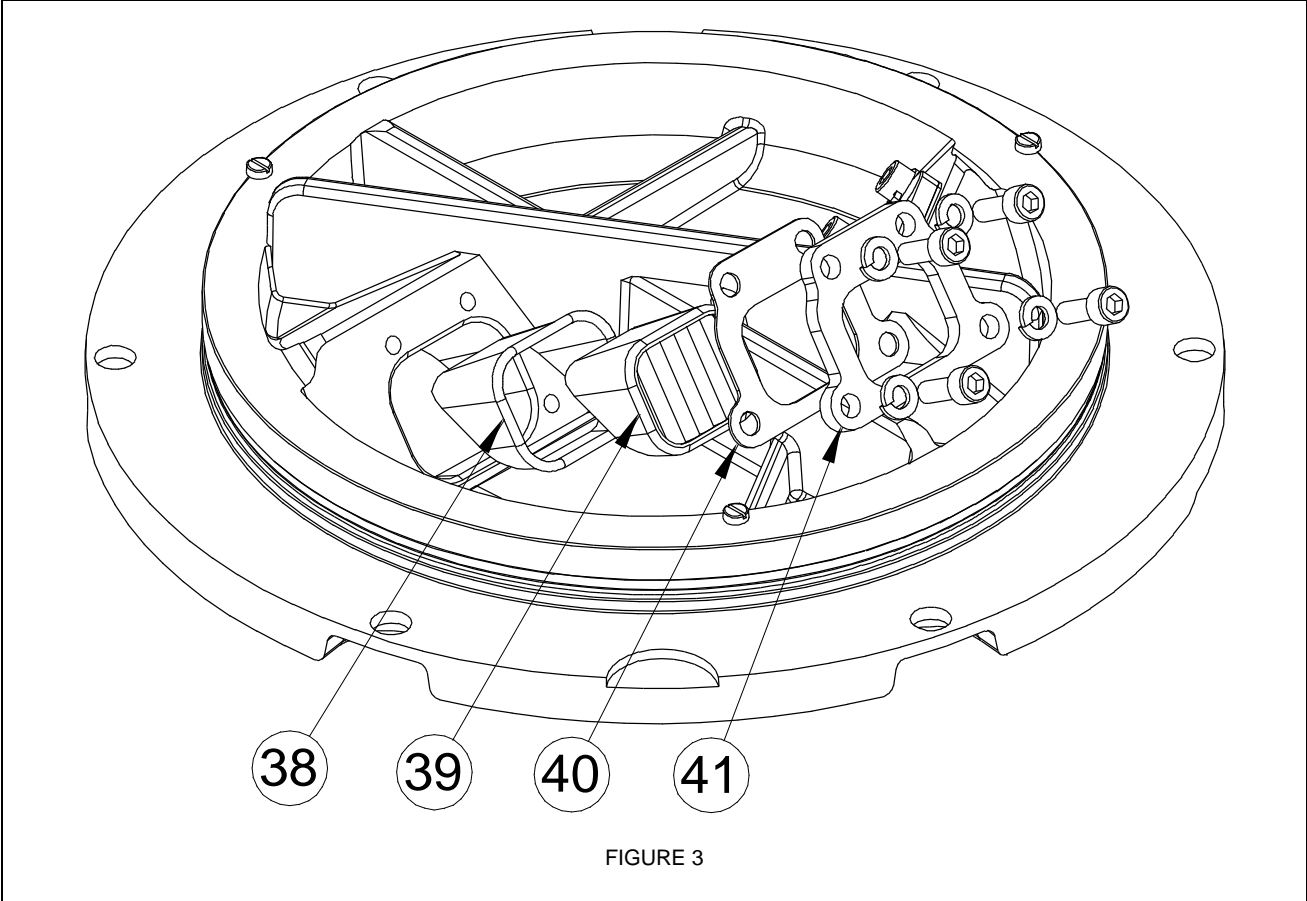
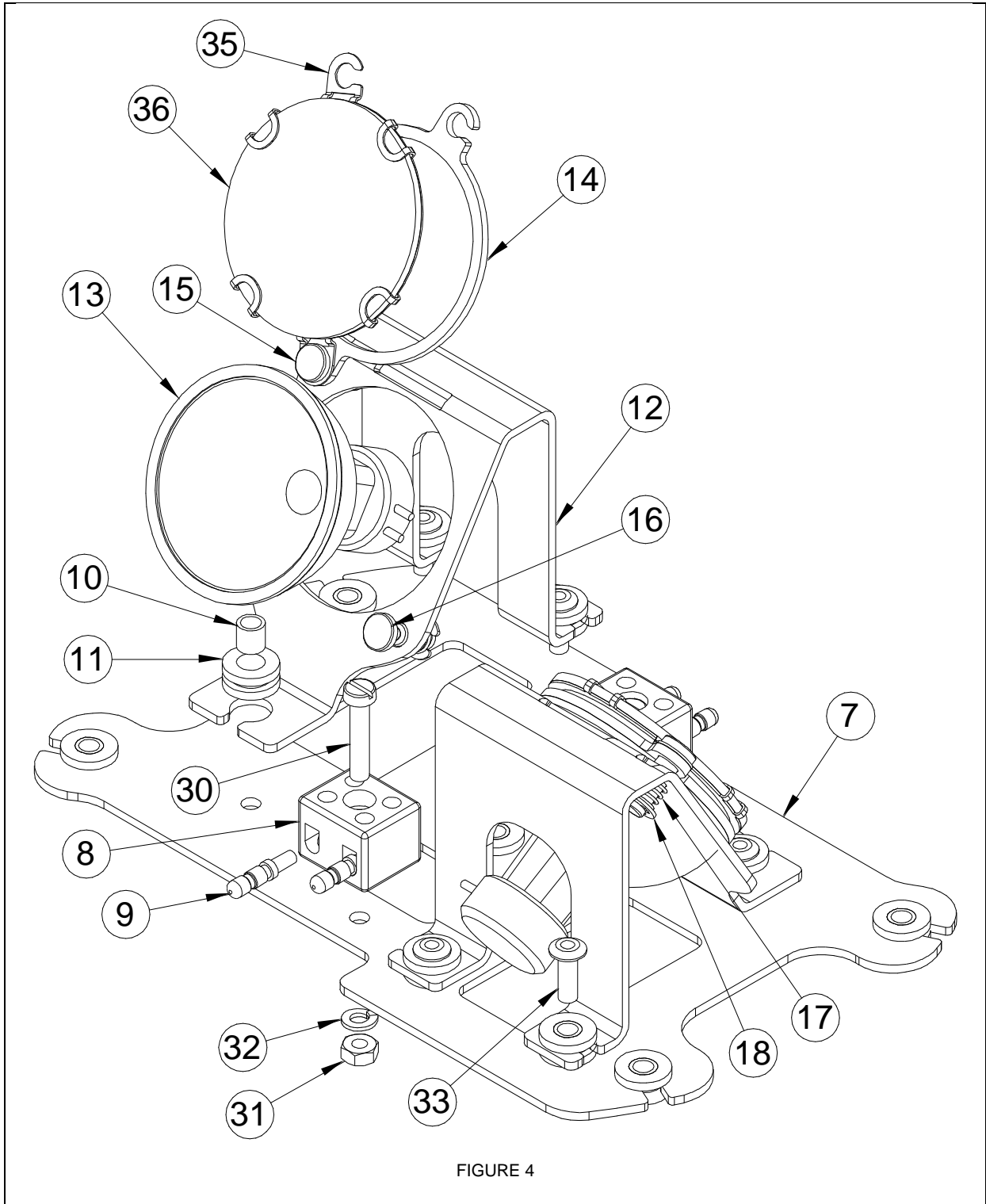

FIGURE 2







Check in to the future

How many aircraft can your airport handle today?
Can this number be increased without adverse effects on the airport's safety level?
It is a known fact that traffic volume will rise in the foreseeable future. More movements will demand monitoring of the entire airport. Requirements will be sharpened and the development of an integrated system

controlling not only ground movements but also air traffic close to the airport is of the highest interest.
The International Civil Aviation Organization (ICAO) already describes A-SMGCS, Advanced Surface Movement Guidance and Control System, as the answer to the future modern airport need to control the entire airport space in one superior system.

To a larger extent than today's systems, A-SMGCS will rely on automated processes to give both pilots and traffic controllers exact information about positions and directions. Safegate Group delivers complete A-SMGCS solutions already, as well as all vital parts relating to it. Safegate Group can check your airport into the future – today!



Safegate Group HQ
Djurhagegatan 19
SE-213 76 Malmö, Sweden
Phone: +46 (0)40 699 17 00
Fax: +46 (0)40 699 17 30
E-mail: market@safegate.com

Australia
australia@safegate.com
+61 (0)3 9720-3233

Austria
office@avibit.com
+43 316 429961

Brazil
brazil@safegate.com
+55 11 2137 4405

China
china@safegate.com
+8610-85275297

Dubai
dubai@safegate.com
+971 4 452 75 75

Finland
finland@safegate.com
+358 (0)20754 7700

France
france@safegate.com
+33 (0)1 42 99 60 40

Germany
germany@safegate.com
+49 (0)4121 464 303

India
india@safegate.com
+91 11 4106 1545

Malaysia
malaysia@safegate.com
+60 32 011 3522

Qatar
qatar@safegate.com
+974 436 9628

Russia
russia@safegate.com
+7 495 917 4614

Singapore
singapore@safegate.com
+65 6289 6893

Spain
spain@safegate.com
+34 917 157 598

UK
uk@safegate.com
+44 (0)208 573 0384

USA
usa@safegate.com
+1 763 535 92 99

THORN
Airfield Lighting

IDMAN

avibit
AIR TRAFFIC SOLUTIONS

SAFEGATE
GROUP 

Safegate Group offers solutions for increased safety, efficiency and environmental benefits to airports worldwide. The company was founded in 1973 and has its headquarters in Malmö, Sweden. Safegate Group has more than 70 partners around the globe in order to be close to its customers. Earlier members of Safegate Group include Thorn AFL and Idman, who both have over 40 years of experience in airfield lighting solutions for airports and heliports. The latest member of Safegate Group is Avibit, a leading provider of next generation software applications and integration of efficient air traffic control systems. Safegate Group's complete range of products and services, a "one-stop shop", provides solutions to customers and airborne travellers around the globe.

www.safegate.com