



8-inch F-Range heliport, runway and taxiway lights type FTO

User Manual

UM-5023, Rev. 2.1, 2022/06/07

**ADB
SAFEGATE**

A.0 Disclaimer / Standard Warranty

CE certification

The equipment listed as CE certified means that the product complies with the essential requirements concerning safety and hygiene. The European directives that have been taken into consideration in the design are available on written request to ADB SAFEGATE.

ETL certification

The equipment listed as ETL certified means that the product complies with the essential requirements concerning safety and FAA Airfield regulations. The FAA directives that have been taken into consideration in the design are available on written request to ADB SAFEGATE.

All Products Guarantee

ADB SAFEGATE will correct by repair or replacement per the applicable guarantee above, at its option, equipment or parts which fail because of mechanical, electrical or physical defects, provided that the goods have been properly handled and stored prior to installation, properly installed and properly operated after installation, and provided further that Buyer gives ADB SAFEGATE written notice of such defects after delivery of the goods to Buyer. Refer to the Safety section for more information on Material Handling Precautions and Storage precautions that must be followed.

ADB SAFEGATE reserves the right to examine goods upon which a claim is made. Said goods must be presented in the same condition as when the defect therein was discovered. ADB SAFEGATE further reserves the right to require the return of such goods to establish any claim.

ADB SAFEGATE's obligation under this guarantee is limited to making repair or replacement within a reasonable time after receipt of such written notice and does not include any other costs such as the cost of removal of defective part, installation of repaired product, labor or consequential damages of any kind, the exclusive remedy being to require such new parts to be furnished.

ADB SAFEGATE's liability under no circumstances will exceed the contract price of goods claimed to be defective. Any returns under this guarantee are to be on a transportation charges prepaid basis. For products not manufactured by, but sold by ADB SAFEGATE, warranty is limited to that extended by the original manufacturer. This is ADB SAFEGATE's sole guarantee and warranty with respect to the goods; there are no express warranties or warranties of fitness for any particular purpose or any implied warranties of fitness for any particular purpose or any implied warranties other than those made expressly herein. All such warranties being expressly disclaimed.

Standard Products Guarantee

Products manufactured by ADB SAFEGATE are guaranteed against mechanical, electrical, and physical defects (excluding lamps) which may occur during proper and normal use for a period of two years from the date of ex-works delivery, and are guaranteed to be merchantable and fit for the ordinary purposes for which such products are made.



Note

See your sales order contract for a complete warranty description.

Replaced or repaired equipment under warranty falls into the warranty of the original delivery. No new warranty period is started for these replaced or repaired products.

FAA Certified products manufactured by ADB SAFEGATE

ADB SAFEGATE L858 Airfield Guidance Signs are warranted against mechanical and physical defects in design or manufacture for a period of 2 years from date of installation, per FAA AC 150/5345-44 (applicable edition).

ADB SAFEGATE LED products (with the exception of obstruction lighting) are warranted against electrical defects in design or manufacture of the LED or LED specific circuitry for a period of 4 years from date of installation, per FAA EB67 (applicable edition). These FAA certified constant current (series) powered LED products must be installed, interfaced and powered with and through products certified under the FAA Airfield Lighting Equipment Program (ALECP) to be included in this 4 (four) year warranty. This includes, but is not limited to, interface with products such as Base Cans, Isolation Transformers, Connectors, Wiring, and Constant Current Regulators.



Note

See your sales order contract for a complete warranty description.

Replaced or repaired equipment under warranty falls into the warranty of the original delivery. No new warranty period is started for these replaced or repaired products.

Liability



WARNING

Use of the equipment in ways other than described in the catalog leaflet and the manual may result in personal injury, death, or property and equipment damage. Use this equipment only as described in the manual.

ADB SAFEGATE cannot be held responsible for injuries or damages resulting from non-standard, unintended uses of its equipment. The equipment is designed and intended only for the purpose described in the manual. Uses not described in the manual are considered unintended uses and may result in serious personal injury, death or property damage.

Unintended uses, includes the following actions:

- Making changes to equipment that have not been recommended or described in this manual or using parts that are not genuine ADB SAFEGATE replacement parts or accessories.
- Failing to make sure that auxiliary equipment complies with approval agency requirements, local codes, and all applicable safety standards if not in contradiction with the general rules.
- Using materials or auxiliary equipment that are inappropriate or incompatible with your ADB SAFEGATE equipment.
- Allowing unskilled personnel to perform any task on or with the equipment.

© ADB SAFEGATE BV

This manual or parts thereof may not be reproduced, stored in a retrieval system, or transmitted, in any form or by any means, electronic, mechanical, photocopying, recording, nor otherwise, without ADB SAFEGATE BV's prior written consent.

This manual could contain technical inaccuracies or typographical errors. ADB SAFEGATE BV reserves the right to revise this manual from time to time in the contents thereof without obligation of ADB SAFEGATE BV to notify any person of such revision or change. Details and values given in this manual are average values and have been compiled with care. They are not binding, however, and ADB SAFEGATE BV disclaims any liability for damages or detriments suffered as a result of reliance on the information given herein or the use of products, processes or equipment to which this manual refers. No warranty is made that the use of the information or of the products, processes or equipment to which this manual refers will not infringe any third party's patents or rights. The information given does not release the buyer from making their own experiments and tests.

TABLE OF CONTENTS

1.0 Safety	1
1.1 Safety Messages	1
1.1.1 Introduction to Safety	2
1.1.2 Intended Use	2
1.1.3 Material Handling Precautions: Storage	3
1.1.4 Material Handling Precautions: Fasteners	3
1.1.5 Maintenance Safety	4
1.1.6 Material Handling Precautions, ESD	4
1.1.7 Arc Flash and Electric Shock Hazard	5
2.0 About this Manual	7
2.1 How to work with the manual	7
2.2 Abbreviations and terms — AGL	7
2.3 Customer Comments and Proposals	7
2.4 Parts Identification	7
3.0 Product Information FTO inset Lights	9
3.1 Introduction to 8-inch F- Range FTO taxiway inset light	9
3.1.1 Runway and Taxiway	10
3.1.2 Differences between versions for runway and taxiway use	12
3.1.3 Film disc cut-out	12
3.1.4 Ordering Code FTO Runway and Taxiway	13
3.2 Introduction to 8-inch F- Range FTO heliport inset light	14
3.2.1 Heliport	15
3.2.2 Differences between versions for heliport use	17
3.2.3 Ordering Code FTO Heliport	18
3.3 Equipment supplied	19
3.4 Equipment required for installation and maintenance	19
4.0 Installation	21
4.1 Introduction	21
4.2 Safety instruction — Fixing elements Important safety notifications	21
4.3 General recommendations regarding installation	21
4.3.1 Receiving, storage and unpacking	21
4.3.2 Electrical connection	22
4.3.3 Base Earthing	22
4.4 How to mount the light assembly?	22
4.4.1 Use the correct fixing hardware	22
4.4.2 Installation Procedure	23
4.5 Adapter ring Installation	24
5.0 Maintenance	25
5.1 Overall maintenance — types and tasks	25
5.1.1 In-the-field-maintenance	25
5.1.2 Preventive maintenance — Part 1	25
5.1.3 Preventive maintenance — Part 2	25
5.2 Fixture and component related maintenance — detailed procedures	26
5.2.1 How to lift the light assembly out of the base or adapter ring	26
5.2.2 How to open the light assembly	27
5.2.3 How to replace the lamp	28
5.2.4 How to replace the outer lens	30
5.2.5 How to replace the optical assembly	33
5.2.6 How to replace the cable set assembly	34
5.2.7 How to close and test the light fixture	35
5.3 Product Troubleshooting	36
5.4 Accessories	37
5.4.1 Tool case	37

5.4.2 Additional accessories	38
5.4.3 Fixing Elements	38
6.0 Spare parts	39
6.1 Exploded Views	40
6.1.1 Exploded View Standard FTO	40
6.1.2 Exploded View Special Version TLOF	41
6.2 Complete Fixtures and Components	41
6.2.1 Fixtures and Main Assemblies of the FTO Taxiway and FTO TLOF Inset Lights	41
6.2.2 FTO Taxiway Cover and Optical Assembly Parts	42
6.2.3 FTO TLOF Cover and optical Assembly Parts	43
6.2.4 FTO Taxiway and FTO TLOF inner Cover Assembly Components	44
6.3 Fixing hardware kits	45
6.4 Screws Overview	46
6.5 Addendum FTO 230V	47
A.0 INTEROPERABILITY	49
B.0 POWER TABLE	51
C.0 CABLE LOSS	53
D.0 SUPPORT	55
D.1 Telephoning Customer Service	55
D.2 ADB SAFEGATE Website	55
D.3 Disposal	56
D.4 Recycling	56
D.4.1 Local Authority Recycling	56
D.4.2 ADB SAFEGATE Recycling	56

List of Figures

Figure 1: Fixture profile	23
Figure 2: Installation drawing	24
Figure 3: Light opening procedure 1	27
Figure 4: Light opening procedure 2	27
Figure 5: Light opening procedure 3	28
Figure 6: Light opening procedure 4	28
Figure 7: Lamp replacement 1	29
Figure 8: Lamp replacement 2	29
Figure 9: Lens replacement	31
Figure 10: Optical assembly replacement procedure	33
Figure 11: Cable assembly replacement	34
Figure 12: Closing procedure 1	35
Figure 13: Closing procedure 2	35
Figure 14: FTO light exploded view	40
Figure 15: FTO TLOF light exploded view	41
Figure 16: Addendum — Profile	47
Figure 17: Addendum — Exploded View	48

List of Tables

Table 1: Preventive maintenance tasks	25
Table 2: Troubleshooting table	36
Table 3: Maintenance tools overview	37
Table 4: Additional accessories overview	38
Table 5: Fixtures and main assemblies of FTO Taxiway and FTO TLOF inset lights	41
Table 6: Components of the FTO Taxiway covers and optical assemblies	42
Table 7: Components of the FTO Taxiway covers and optical assemblies	43
Table 8: Optical assemblies overview	43
Table 9: Components of the FTO Taxiway and FTO TLOF inner covers assemblies	44
Table 10: Fixing hardware kits of F-Range inset lights	45
Table 11: Screws and references	46
Table 12: Interoperability matrix	49

1.0 Safety

Introduction to Safety

This section contains general safety instructions for installing and using ADB SAFEGATE equipment. Some safety instructions may not apply to the equipment in this manual. Task- and equipment-specific warnings are included in other sections of this manual where appropriate.

1.1 Safety Messages

HAZARD Icons used in the manual

For all HAZARD symbols in use, see the Safety section. All symbols must comply with ISO and ANSI standards.

Carefully read and observe all safety instructions in this manual, which alert you to safety hazards and conditions that may result in personal injury, death or property and equipment damage and are accompanied by the symbol shown below.



WARNING

Failure to observe a warning may result in personal injury, death or equipment damage.



DANGER - Risk of electrical shock or ARC FLASH

Disconnect equipment from line voltage. Failure to observe this warning may result in personal injury, death, or equipment damage. ARC Flash may cause blindness, severe burns or death.



WARNING - Wear personal protective equipment

Failure to observe may result in serious injury.



WARNING - Do not touch

Failure to observe this warning may result in personal injury, death, or equipment damage.



CAUTION

Failure to observe a caution may result in equipment damage.

Qualified Personnel



Important Information

The term **qualified personnel** is defined here as individuals who thoroughly understand the equipment and its safe operation, maintenance and repair. Qualified personnel are physically capable of performing the required tasks, familiar with all relevant safety rules and regulations and have been trained to safely install, operate, maintain and repair the equipment. It is the responsibility of the company operating this equipment to ensure that its personnel meet these requirements.

Always use required personal protective equipment (PPE) and follow safe electrical work practice.

1.1.1 Introduction to Safety



CAUTION

Unsafe Equipment Use

This equipment may contain electrostatic devices, hazardous voltages and sharp edges on components

- Read installation instructions in their entirety before starting installation.
- Become familiar with the general safety instructions in this section of the manual before installing, operating, maintaining or repairing this equipment.
- Read and carefully follow the instructions throughout this manual for performing specific tasks and working with specific equipment.
- Make this manual available to personnel installing, operating, maintaining or repairing this equipment.
- Follow all applicable safety procedures required by your company, industry standards and government or other regulatory agencies.
- Install all electrical connections to local code.
- Use only electrical wire of sufficient gauge and insulation to handle the rated current demand. All wiring must meet local codes.
- Route electrical wiring along a protected path. Make sure they will not be damaged by moving equipment.
- Protect components from damage, wear, and harsh environment conditions.
- Allow ample room for maintenance, panel accessibility, and cover removal.
- Protect equipment with safety devices as specified by applicable safety regulations
- If safety devices must be removed for installation, install them immediately after the work is completed and check them for proper functioning prior to returning power to the circuit.

Failure to follow this instruction can result in serious injury or equipment damage

Additional Reference Materials



Important Information

- IEC - International Standards and Conformity Assessment for all electrical, electronic and related technologies.
- IEC 60364 - Electrical Installations in Buildings.
- FAA Advisory: AC 150/5340-26 (current edition), Maintenance of Airport Visual Aid Facilities.
- Maintenance personnel must refer to the maintenance procedure described in the ICAO Airport Services Manual, Part 9.
- ANSI/NFPA 79, Electrical Standards for Metalworking Machine Tools.
- National and local electrical codes and standards.

1.1.2 Intended Use



CAUTION

Use this equipment as intended by the manufacturer

This equipment is designed to perform a specific function, do not use this equipment for other purposes

- Using this equipment in ways other than described in this manual may result in personal injury, death or property and equipment damage. Use this equipment only as described in this manual.

Failure to follow this instruction can result in serious injury or equipment damage

1.1.3 Material Handling Precautions: Storage



CAUTION

Improper Storage

Store this equipment properly

- If equipment is to be stored prior to installation, it must be protected from the weather and kept free of condensation and dust.

Failure to follow this instruction can result in equipment damage

1.1.4 Material Handling Precautions: Fasteners



DANGER

Foreign Object Damage - FOD

This equipment may contain fasteners that may come loose - torque properly.

- Only use fasteners of the same type as the one originally supplied with the equipment.
- Use of incorrect combination of gaskets, bolts and nuts can create severe damages to the product installation and create safety risk .
- You need to know what base the light fixture will be installed in, in order to chose the correct gasket, bolts and nuts.
- Bolt type, length, and torque value are determined by type of base, height of spacers used, and clamp force required in FAA Engineering Brief No 83 (latest revision).
- Due to the risk of bolts vibrating loose, do not use any type of washer with the fixing bolts (such as split lock washers) other than an anti-vibration washer. Anti-vibration washers as defined in FAA EB 83 (latest edition) must be used. For installations other than FAA, use the base can manufacturer's recommendations.
- Always tighten the fasteners to the recommended torque. Use a calibrated torque wrench and apply the recommended adhesive type.
- Obey the instructions of the adhesives necessary for the fasteners.

Failure to follow these warnings may cause the fasteners to loosen, damage the equipment, potentially to loosen the equipment. This can lead to a highly dangerous situation of FOD, with potential lethal consequences.



Note

To minimize the risk of errors, the ADB SAFEGATE Sales Representative will have information on which gasket goes with which base. This information is also provided in the product Data sheets, the User Manuals and the Spare Part Lists.



CAUTION

Use of incorrect combination of gaskets, bolts and nuts can create severe damages to the product installation and create multiple safety risks.

To obtain a safe and watertight installation the O-ring and retaining bolt stated in the document must be used.

You need to know what base the light fixture will be installed in, in order to choose the correct gasket, bolts and nuts.

Failure to follow these cautions can result in equipment damage or aircraft FOD.

1.1.5 Maintenance Safety



DANGER

Electric Shock Hazard

This equipment may contain electrostatic devices

- Do not operate a system that contains malfunctioning components. If a component malfunctions, turn the system OFF immediately.
- Disconnect and lock out electrical power.
- Allow only qualified personnel to make repairs. Repair or replace the malfunctioning component according to instructions provided in its manual.

Failure to follow these instructions can result in death or equipment damage

1.1.6 Material Handling Precautions, ESD



CAUTION

Electrostatic Sensitive Devices

This equipment may contain electrostatic devices

- Protect from electrostatic discharge.
- Electronic modules and components should be touched only when this is unavoidable e.g. soldering, replacement.
- Before touching any component of the cabinet you shall bring your body to the same potential as the cabinet by touching a conductive earthed part of the cabinet.
- Electronic modules or components must not be brought in contact with highly insulating materials such as plastic sheets, synthetic fiber clothing. They must be laid down on conductive surfaces.
- The tip of the soldering iron must be grounded.
- Electronic modules and components must be stored and transported in conductive packing.

Failure to follow this instruction can result in equipment damage

1.1.7 Arc Flash and Electric Shock Hazard



DANGER

Series Circuits have Hazardous Voltages

This equipment produces high voltages to maintain the specified current - Do NOT Disconnect while energized.

- Allow only qualified personnel to perform maintenance, troubleshooting, and repair tasks.
- Only persons who are properly trained and familiar with ADB SAFEGATE equipment are permitted to service this equipment.
- An open airfield current circuit is capable of generating >5000 Vac and may appear OFF to a meter.
- Never unplug a device from a constant current circuit while it is operating; Arc flash may result.
- Disconnect and lock out electrical power.
- Always use safety devices when working on this equipment.
- Follow the recommended maintenance procedures in the product manuals.
- Do not service or adjust any equipment unless another person trained in first aid and CPR is present.
- Connect all disconnected equipment ground cables and wires after servicing equipment. Ground all conductive equipment.
- Use only approved ADB SAFEGATE replacement parts. Using unapproved parts or making unapproved modifications to equipment may void agency approvals and create safety hazards.
- Check the interlock systems periodically to ensure their effectiveness.
- Do not attempt to service electrical equipment if standing water is present. Use caution when servicing electrical equipment in a high-humidity environment.
- Use tools with insulated handles when working with airfield electrical equipment.

Failure to follow these instructions can result in death or equipment damage

2.0 About this Manual

2.1 How to work with the manual

1. Become familiar with the structure and content.
2. Carry out the actions completely and in the given sequence.

2.2 Abbreviations and terms — AGL

Abbreviations and terms	Description
FAA	Federal Aviation Administration
ICAO	International Civil Aviation Organization
IEC	International Electrical Committee
ISO	International Standardization Organization
ANSI	American National Standards Institute
NFPA	National Fire Protection Association
AC	Advisory Circular (FAA)
ESD	Electro-Static Discharge; Electrostatic-Sensitive Devices
LED	Light Emitting Diode
PPE	Personal Protective Equipment
FOD	Foreign Object Debris
Mounting support	A piece of equipment, on which the fixture is installed.
Toe-in	The toe-in angle is the angle the beam of light makes with the longitudinal axis of the runway or taxiway.

2.3 Customer Comments and Proposals

This manual has been compiled with all possible care and in view of providing a valuable and practical tool to the Airport Maintenance personnel.

We encourage customers to address us their comments and proposals for improving further the contents of this manual.

Communications should be addressed to the **Customer Service Department** of ADB SAFEGATE:

ADB SAFEGATE

585, Leuvensesteenweg

B-1930 Zaventem - Belgium

Tel. 32 2 722 17 11 Fax 32 2 722 17 64

E-mail: info@adbsafegate.com

2.4 Parts Identification

Parts identification symbols (e.g. A1, B4, ...) appearing in the text refer to the [Exploded Views](#) section.

3.0 Product Information FTO inset Lights

The ADB FTO inset light is a light fixture which provides optimum visual guidance with minimal maintenance, low life-cycle costs and maximum reliability. It is designed to withstand the high impact and roll-over loads imposed by today's wide body aircraft during taxiing operations while remaining waterproof and serviceable.

The FTO fixture is shipped ready for installation on an ADB 8" shallow base or on 12" shallow base or FAA deep bases (L-867 size B or L-868 size B) with an adapter ring

The ADB inset lights type FTO are intended to use as omnidirectional light for:

Airports:

- Taxiway and Apron edge;
- Runway circling guidance;
- Low Intensity Runway edge;
- Aircraft stand manoeuvring guidance.

Heliports:

- Final approach and take-off area;
- Special version (reflector lamp) for TLOF.

3.1 Introduction to 8-inch F- Range FTO taxiway inset light

In this chapter you will find all the information about the shipment and the identification of the ADB SAFEGATE FTO inset light for taxiways.

This manual describes procedures for the installation, maintenance and troubleshooting of the FTO taxiway inset light.

This manual covers the FTO light fixture for taxiway application manufactured in accordance with FAA specification AC 150/5345-46 (except for photometry when it differs from ICAO Annex 14) and compliant to ICAO Annex 14.

The ADB SAFEGATE 8-inch F-Range FTO Inset Light is a light fixture which provides optimum visual guidance with minimal maintenance, low life-cycle costs and maximum reliability. It is designed to withstand the high impact and roll-over loads imposed by today's widebody aircraft during landing and take-off operations while remaining waterproof and serviceable.

The FTO Inset Light fixture is shipped ready for installation on an ADB SAFEGATE 8-inch shallow base or on 12-inch shallow base or FAA deep bases (L-867 size B or L-868 size B) with an adapter ring .



Note

For more detailed information on interoperability, refer to the appendix, [INTEROPERABILITY](#) section.

3.1.1 Runway and Taxiway

Compliance with Standards (current Versions)

FAA	AC150/5345-46
ICAO	Annex 14, Volume I Annex 14, Volume II
NATO	STANAG 3316, part III

Uses

- Taxiway and apron edge
- Runway circling guidance
- Low intensity runway edge
- Aircraft stand manoeuvring guidance

Features and Benefits

- Efficiency**
- Designed and built with simplicity and ease of maintenance in mind
 - Extensive use of aluminum alloys limits fixture weight to less than 8 kg to ease handling in the field
 - Many components are common to all F-range lights
 - Outer prisms mechanically clamped to light cover through molded, replaceable seals: prism replacement by Airport maintenance personnel is fast and easy and does not require any sealing compound or resin
 - No optical adjustment required after replacement of lamp, lens or reflector
 - Specific tools have been developed to ease installation and subsequent maintenance
 - Plug for pressure-testing of fixture after overhaul
 - Absence of negative slope guarantees optimal light output under worst weather conditions
 - Lens mechanically clamped to light cover through molded, replaceable seals. Lens replacement by airport maintenance personnel is fast and easy and does not require any sealing compound or resin.
 - Available for series (6,6A) and parallel supply (230V AC)
- Sustainability**
- Lightweight, sturdy, low-energy and environment friendly lighting fixtures (no cadmium plating)
 - Normal protrusion (10 mm) reduces vibrations induced in aircraft Landing gear and in lighting fixture itself, thereby increasing lifetime, particularly for the lamps
 - Smooth outer surface of light cover avoids tire damage and makes light less sensitive to snowplows
 - Long life halogen lamps: 1000 hours at full intensity, in excess of 3000 hours in practical use
 - Low temperature lights: temperature at center of top cover remains below 160 °C ICAO specified limit
 - IP67 protected, finish: aluminum alloy cover, inner cover and optical support; plain stainless steel hardware
 - Hardened optical glass lens, clear or through colored; no need for separate color filter



Note

Standard adapter rings for installation on 12-inch diameter FAA deep bases. Specific rings available to fit mounting bases and seating rings to other standards.

- Safety**
- Part of a comprehensive range of 8- and 12-inch diameter inset lights covering all aviation ground lighting requirements
 - Shallow gully in front of prism windows maintains optimal light output under heavy rainfall



Note

For use on heliports, refer to DS-5019.

Accessories

Refer to the F-range user manual for the 8-inch FTO light.

Power Supply

6.6 A through an isolating transformer.

Two or more fittings may be series-connected and fed from an isolating transformer, making use of optional film disc or electronic cut-outs.



Note

For parallel supply, please contact ADB SAFEGATE.

Maintenance and Installation

Refer to the F-Range user manual for the 8-inch FTO light and to the interoperability info for installation in a specific base.

Dimensions and Weight

Outer diameter / depth	Approx. 210 x 210 / 100 mm
	8.3 x 8.3 / 3.9 in
Weight without packaging	Approx. 2.7 kg
	5.9 lb

Operating Conditions

Operating temperature	-122 to +122 °F / -50 to +50 °C
Storage temperature	-131 to +131 °F / -55 to +55 °C
Relative humidity	Up to 98 % at +77 °F / 25° C

ANNEX

Fixture type	Fixture load	Isolation transformer			CCR load
		Rating	Loss	Efficiency	
FTO (omnidirectional)	48 VA	45 W	9 VA	0.85	57 VA
FTO (omnidirectional)	65 VA	65 W	11 VA	0.85	76 VA
FTO (omnidirectional)	45 VA	45 W	8 VA	0.85	53 VA



Note

- Extra losses in secondary cables or due to extra equipment (e.g. ILCMS remotes) are not included in above table; these extra losses will result in a higher required size of isolation transformers.
 - Extra losses in primary cables are not included in above table; these extra losses will result in a higher required CCR load.
 - Efficiency of the secondary transformer depends on the supplier of secondary transformers.
-

Explanation to power table

Lamp: 45, 48 or 65 W — 6,6 A PKX30D prefocus halogen lamp with nominal lifetime of 1000 hours

Color	Lamp power		
	45 W	48 W	65 W
White	x	-	x
Yellow	x	-	x
Red	x	-	-
Blue	x	-	-

For detailed information, please refer to the mounting instructions supplied with the fittings.

The ADB SAFEGATE technical team is at disposal of users and contractors to provide guidance and advice in order to help solving any particular installation problem.

3.1.2 Differences between versions for runway and taxiway use

All the inset lights used for a particular function look externally identical. The differences between versions depend on the lens color (B2) and lamp power (D). Make sure to use the correct version when installing the light onto its base.

3.1.3 Film disc cut-out

For some applications, optional film disc cut-outs are available. They form an electrical bypass over the lamp within 15 seconds after lamp failure. After a lamp failure, the film disc cut-out must be replaced.

3.1.4 Ordering Code FTO Runway and Taxiway

Ordering Code

1 T 0 □ □ □ □ □ □ □ □

FITTING VERSION

A = ADB
F = French
G = German

LAMP POWER

1 = 1 X 45 W (without cut-out)
4 = 1 X 45 W (with cut-out, for 6,6 A series supplied lights only)
5 = 1 X 65 W (with cut-out, for 6,6 A series supplied lights only)

BEAM COLOR

1 = White
2 = Red
4 = Yellow
5 = Blue (Only 45 W and series supply)

FIXED DIGIT

0 = FREE DIGIT

FIXED DIGIT

0 = FREE DIGIT

SUPPLY

1 = 1 Plug

BASE

1 = None
7 = 8 in with transformer 45 W (1 entry, only for parallel supply)
A = ERNI (With gasket for ERNI bases, 1 entry, only for parallel supply)

SPECIAL EXECUTIONS

0 = Standard (1T0A... 1T0F... 1T0G...)

EXECUTIONS

3 = Without fixing hardware

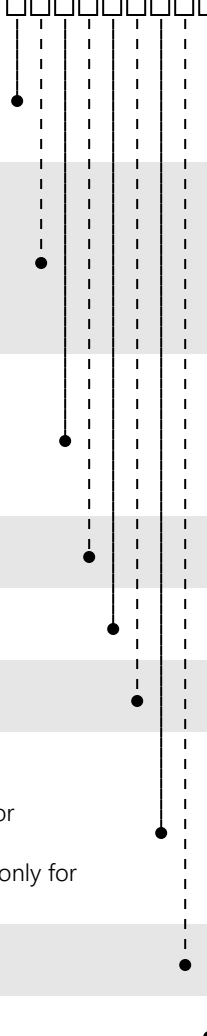

Note

- Deep base and / or adapter rings to be ordered separately.
- Use of a cutout is not compatible with the *Lamp Fault Detection (LFD)* functionality of a regulator.
- Special execution for heliports with 230 V 50/60 Hz parallel supply: 65 W / white 1T0A21001900; 65 W / red 1T0A22001900 and 65 W / yellow 1T0A24001900

3.2 Introduction to 8-inch F- Range FTO heliport inset light

In this chapter you will find all the information about the shipment and the identification of the ADB SAFEGATE FTO inset light for heliports.

This manual describes procedures for the installation, maintenance and troubleshooting of the FTO heliport inset light for TLOF application. For other applications of the FTO, please refer to user manual UM-5020.

This manual covers the FTO light fixture for TLOF application manufactured in accordance with FAA specification AC 150/5345-46 (except for photometry when it differs from ICAO Annex 14) and compliant to ICAO Annex 14.

The ADB SAFEGATE 8-inch F-Range FTO Inset Light is a light fixture which provides optimum visual guidance with minimal maintenance, low life-cycle costs and maximum reliability. It is designed to withstand the high impact and roll-over loads imposed by today's widebody aircraft during landing and take-off operations while remaining waterproof and serviceable.

The FTO Inset Light fixture is shipped ready for installation on an ADB SAFEGATE 8-inch shallow base or on 12-inch shallow base or FAA deep bases (L-867 size B or L-868 size B) with an adapter ring .

The illustration below represents the exploded view of a FTO TLOF inset light:

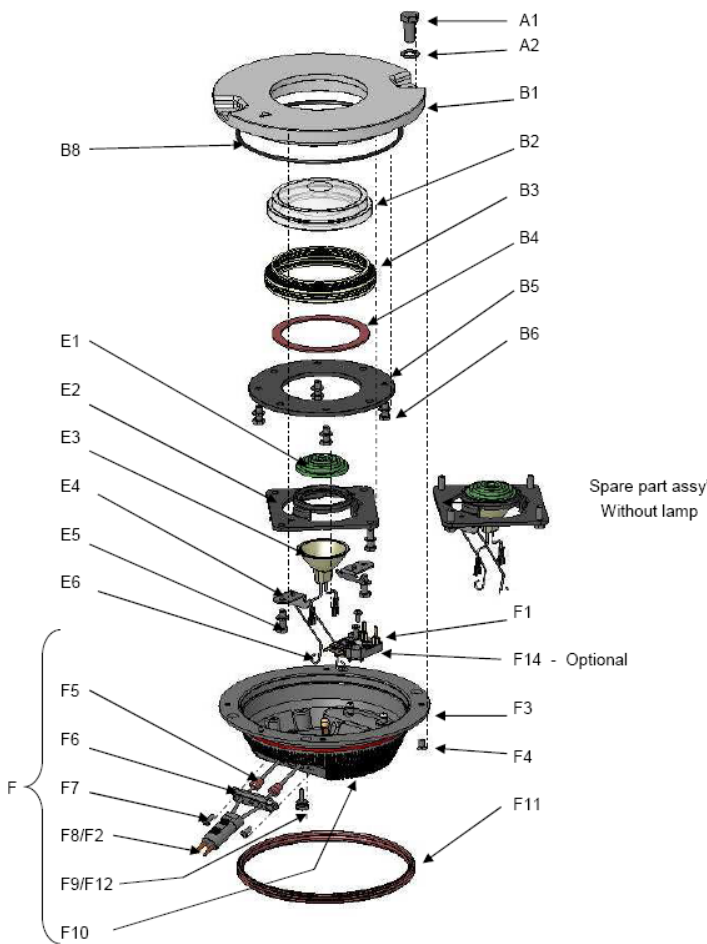

i Note

For more detailed information on interoperability, refer to the appendix, [INTEROPERABILITY](#) section.

3.2.1 Heliport

Compliance with Standards (current Versions)

ICAO	Annex 14, Volume II
NATO	STANAG 3652

Uses

- Touchdown zone and lift off area perimeter (TLOF)
- Final approach and take off area (FATO)
- Aiming point

Features and Benefits

Efficiency

- Designed and built with simplicity and ease of maintenance in mind
- Extensive use of aluminum alloys reduces fitting weight and eases handling in the field
- Many components are common to all F-range lights
- Outer prisms mechanically clamped to light cover through molded, replaceable seals: prism replacement by Airport maintenance personnel is fast and easy and does not require any sealing compound or resin
- No optical adjustment required after replacement of lamp, lens or reflector
- Specific tools have been developed to ease installation and subsequent maintenance
- Plug for pressure-testing of fixture after overhaul
- Absence of negative slope guarantees optimal light output under worst weather conditions
- Lens mechanically clamped to light cover through molded, replaceable seals. Lens replacement by airport maintenance personnel is fast and easy and does not require any sealing compound or resin.
- Available for series (6,6A) and parallel supply (230V AC)

Sustainability

- Lightweight, sturdy, low-energy and environment friendly lighting fixtures (no cadmium plating)
- Normal protrusion (10 mm) reduces vibrations induced in aircraft Landing gear and in lighting fixture itself, thereby increasing lifetime, particularly for the lamps
- Smooth outer surface of light cover avoids tire damage and makes light less sensitive to snowplows
- Long life halogen lamps: 1000 hours at full intensity, in excess of 3000 hours in practical use
- Double water barriers seal all possible moisture ingress paths
- Low temperature lights: temperature at center of top cover remains below 160 °C ICAO specified limit
- IP67 protected, finish: corrosion-proof aluminum aluminum alloy cover, inner cover and optical support; plain stainless steel hardware
- Hardened optical glass lens, clear or through colored; no need for separate color filter

Note

Standard adapter rings for installation on 12-inch diameter FAA deep bases. Specific rings available to fit mounting bases and seating rings to other standards.

Safety

- Part of a comprehensive range of 8- and 12-inch diameter inset lights covering all heliport lighting requirements
- Shallow gully in front of prism windows maintains optimal light output under heavy rainfall
- Low temperature light



Note

For use on runways or taxiways, refer to DS-5021.

Accessories

Refer to the F-range user manual for the 8-inch FTO heliport light.

Power Supply

Series supply

6.6 A through a series transformer.

Two or more fittings may be series-connected and fed from one series transformer making use of optional film disc or electronic cutouts.

Parallel supply

230 VAC through a step - down transformer, mounted in a dedicated extension of the shallow base.

Maintenance and Installation

Refer to the F-Range user manual for the 8-inch FTO heliport light and to the interoperability info for installation in a specific base.

Dimensions and Weight

Outer diameter / depth	Approx. 210 x 210 / 100 mm
	8.3 x 8.3 / 3.9 in
Weight without packaging	Approx. 2.7 kg
	5.9 lb

Operating Conditions

Operating temperature	-122 to +122 °F / -50 to +50 °C
Storage temperature	-131 to +131 °F / -55 to +55 °C
Relative humidity	Up to 98 % at +77 °F / 25° C

ANNEX

Fixture type	Fixture load	Isolation transformer			CCR load
		Rating	Loss	Efficiency	
FTO - TLOF (omnidirectional)	48 VA	45 W	9 VA	0.85	57 VA
FTO - FATO (omnidirectional)	65 VA	65 W	11 VA	0.85	76 VA
FTO - FATO (omnidirectional)	45 VA	45 W	8 VA	0.85	53 VA
FTO – aiming point (omnidirectional)	45 VA	45 W	8 VA	0.85	53 VA



Note

- Extra losses in secondary cables or due to extra equipment (e.g. ILCMS remotes) are not included in above table; these extra losses will result in a higher required size of isolation transformers.
- Extra losses in primary cables are not included in above table; these extra losses will result in a higher required CCR load.
- Efficiency of the secondary transformer depends on the supplier of secondary transformers.

Explanation to power table

Lamp: 45W, 65W (6.6A PKX30D Halogen lamp), 48W (cold mirror prefocus halogen lamp).

Color	Lamp power		
	45 W	48 W	65 W
White	x	-	x
Yellow	x	-	x
Green	-	x	-

For detailed information, please refer to the mounting instructions supplied with the FTO.

The ADB SAFEGATE technical team is at disposal of users and contractors to provide guidance and advice in order to help solving any particular installation problem.

3.2.2 Differences between versions for heliport use

All the inset lights used for a particular function look externally identical. The differences between versions depend on the lens color (E1) and lamp (E3). Make sure to use the correct version when installing the light onto its base.

3.2.3 Ordering Code FTO Heliport

Ordering Code

1 T 0 □ □ □ □ □ □ □ □

FITTING VERSION

- A = ADB
- F = French
- G = German

LAMP POWER

- 1 = 1 X 45 W (without cut-out; except blue and TLOF)
- 2 = 1 X 65 W (without cut-out)
- 3 = 1 X 48 W (without cut-out, for Green TLOF heliport light)
- 4 = 1 X 45 W (with cut-out, for 6,6 A series supplied lights only)
- 5 = 1 X 65 W (with cut-out, for 6,6 A series supplied lights only)
- 6 = 1 X 48 W (with cut-out, for 6,6 A series supplied Green TLOF light only)

BEAM COLOR

- 1 = White
- 3 = Green
- 4 = Yellow

FIXED DIGIT

- 0 = FREE DIGIT

FIXED DIGIT

- 0 = FREE DIGIT

SUPPLY

- 1 = 1 Plug

BASE

- 1 = None
- 8 = 8 in with transformer 48 W (1 entry, only for parallel supply)
- 9 = 8 in with transformer 65 W (1 entry, only for parallel supply)
- A = (With gasket for ERNI bases, one entry, only for parallel supply)

SPECIAL EXECUTIONS

- 0 = Standard (1T0A... 1T0F... 1T0G...)

EXECUTIONS

- 3 = Without fixing hardware

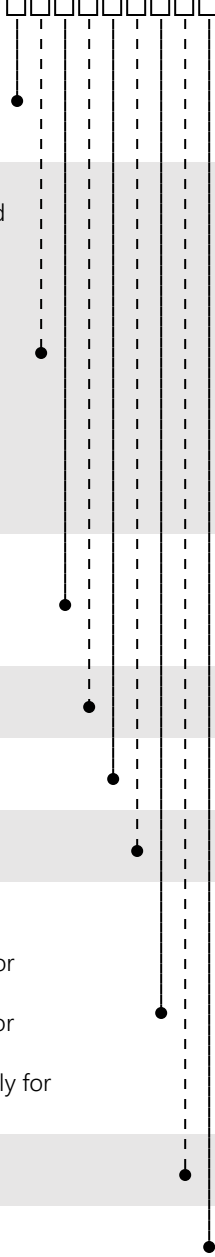

Note

- Deep base and / or adapter rings to be ordered separately.
- Use of a cutout is not compatible with the *Lamp Fault Detection (LFD)* functionality of a regulator.
- Special execution for heliports with 230 V 50/60 Hz parallel supply: 65 W / white 1T0A21001900; 65 W / red 1T0A22001900 and 65 W / yellow 1T0A24001900

3.3 Equipment supplied

Each unit is supplied completely assembled, tested and sealed, ready for installation. The electrical connection is made via a cable assembly with FAA L-823 style 2-pole plug. A labyrinth gasket is included.

The FTO light for 230V AC parallel supply is always supplied mounted on a shallow base. (with dedicated extension housing the transformer).

Each unit is individually packed in a durable, cushioned and corrugated cardboard box, labeled with ADB SAFEGATE and ordering numbers.

The user manual is available at: www.adbsafegate.com.

3.4 Equipment required for installation and maintenance

Beyond the light itself, some equipment is required for installation and maintenance.

This equipment is not supplied with the light but can be obtained through ADB SAFEGATE.



Note

It is listed in [Accessories](#) section

4.0 Installation

4.1 Introduction

This chapter instructs you how to connect and mount the FTO inset light on its base or adapter ring.

It includes important safety notifications regarding the choice and use of fixing hardware.



NOTICE

It is assumed that the base supporting the FTO inset light, the adapter ring (if needed) and the secondary connector are already installed.

4.2 Safety instruction — Fixing elements Important safety notifications

Various types of fixing hardware can be used for the fixation of the light on its base or adapter ring (e.g. screws or studs and nuts). Moreover, bases and adapter rings may be supplied with threaded holes according either to ISO metric or UNC standards.



WARNING

Only use fixing hardware of the same type as the one originally supplied with the base or adapter ring!

Always tighten the fixing hardware to the recommended torque, using a calibrated torque wrench and applying the recommended type of sealant!

Refer to [How to mount the light assembly?](#) section for the tool to use, requirement description regarding the use of Loctite adhesives / sealants and the necessary torque to apply.

Do not insert a 3 / 8- to 16-inch UNC screw in a M10 threaded hole. Such a combination damages the female thread and does not ensure a correct fastening so that the screw could become loose under repeated operation of rolling aircrafts. Using screws of incorrect standard might lead to either damage to the thread in the base or to an incorrect fixation of the lights.

Generally, using fixing hardware of a different type of the one originally supplied with the bases or adapter rings, or tightening it at an incorrect torque, may lead to a loosening of the fixing hardware, damage to the light and base, and potentially to the separation of the light fitting or parts thereof from its base. This can lead to a highly dangerous situation of *Foreign Object Debris (FOD)*, with potential lethal consequences.

4.3 General recommendations regarding installation

4.3.1 Receiving, storage and unpacking

1. Upon receipt of goods at the site store, check all packing for visible damage.
Every damaged box should be opened and its content inspected for damage.

Important

If equipment is damaged, a claim form shall be filed with the carrier immediately. It may then be necessary for the carrier to inspect the equipment.

2. Store the light assembly preferably in its original packing in a protected area.
When stored unpacked, please take care not to damage the cable insulation.
3. Unpack the light assembly at the installation site to avoid damage during transportation and handling.

4.3.2 Electrical connection

The light assemblies covered by this manual are designed for connection to 6.6 or 20-A series circuits via one (or more) L-830 or L-831 series transformer(s) or to a 230V AC parallel circuit. The current to the light should not exceed 6.6 A + 3%.



Note

In case of use on a 20 A series circuit, we consider that the series transformer is a 20 A / 6.6 A transformer.

The series transformers are to be ordered separately.

4.3.3 Base Earthing

Whatever the chosen installation method, it is strongly recommended to earth the base, especially in locations presenting a risk of lightning strikes.



Note

- Failure to earth correctly the base will void the warranty for all damages occurring as a result of voltage surges.
 - Guidelines on how to realize the earthing of the base are given in instruction manual user manual UM-0106.
-

4.4 How to mount the light assembly?



CAUTION

Make sure that the contact surfaces of the light assembly with base or adapter ring and the gaskets are absolutely clean and smooth.

4.4.1 Use the correct fixing hardware

Please refer to [Safety](#) chapter.



CAUTION

Only use fixing hardware of the same type as the one originally supplied with the base or adapter ring!

In ADB SAFEGATE shallow bases delivered since mid-2006, the type of thread can be METRIC M10 or 3/8"-16UNC.

How to be sure of the type of fixing hardware you are using?

- M10 screws require the use of a 17mm socket.
 - 3/8"-16UNC screws require a 9/16" socket, this is approximately 14.3mm.
-



WARNING

On a base or adapter ring with metric M10 female thread, never use a screw that can be fastened with a socket smaller than 17mm. It would indicate that you are inserting a 3/8"-16UNC screw in a M10 female thread.

The opposite -inserting a M10 screw in a 3/8"-16UNC female thread- is impossible.

4.4.2 Installation Procedure



NOTICE

Always take into account the information from the interoperability between light and base. Refer to appendix, [INTEROPERABILITY](#) section.

To mount and connect the light assembly, proceed as follows:

1. In case a light has already been mounted on the base, remnants of Loctite are present in the fixation holes (depending on the type of base used).

Always clean the fixation holes using a cleaning tap for blind holes (preferably use a tap with a right spiral groove) and blow with dry, oil-free compressed air.

2. If the labyrinth gasket (F11) is not installed, put a new, clean one in the dedicated groove at the cover periphery.

Figure 1: Fixture profile

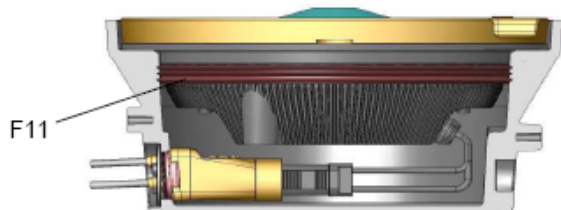

CAUTION

Never reuse an already used gasket.

3. Slightly moisten the gasket with soapy water, to lubricate.



CAUTION

Never lubricate the gasket with silicone or any other kind of grease. Avoid the use of soap containing silicone or glycerine.

4. Connect the light by inserting its two-pole plug into the receptacle of either the shallow base, the secondary cable or the transformer
5. Apply Loctite on the three first threads of the threaded holes in the base, if necessary.



NOTICE

Refer to interoperability between light and base. Please find it in the appendix, [INTEROPERABILITY](#) section.



CAUTION

Always use Loctite 2701 to fasten the light fixture on its support.

6. Gently install the light fixture in the base or the adapter ring and press it home.



CAUTION

Make sure not to drop the light assembly or to pinch the wires when mounting the light on the adapter ring. Verify the light fixture is seating correctly onto the base or adapter ring.

7. Make sure that the lock washers are mounted correctly-dents facing upwards - to avoid denting the cover.

Figure 2: Installation drawing

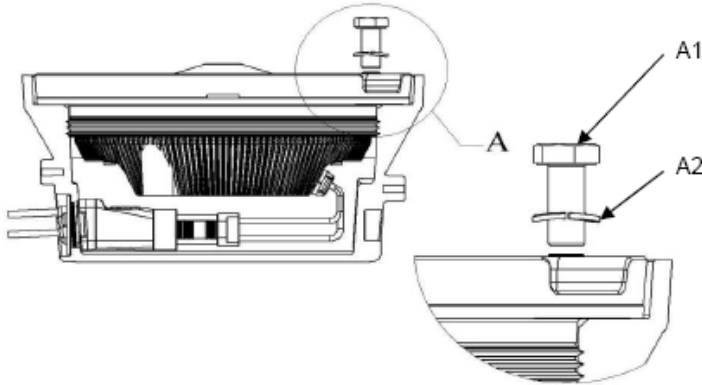

8. Torque down gradually the 2 screws (or self-locking nuts in case of a stud-equipped base).



CAUTION

Make sure the screws are tightened with the correct torque.



NOTICE

Refer to interoperability between light and base. Please find it in the appendix, [INTEROPERABILITY](#) section.

4.5 Adapter ring Installation

To install the adapter ring, proceed as follow:

1. Clean the contact surfaces of the deep base and adapter ring.
In case an adapter ring has already been mounted on the base, remnants of Loctite are present in the fixation holes. Clean them using a cleaning tap for blind holes (preferably use a tap with a right spiral groove) and blow with dry, oil-free compressed air.
2. Put onto the contact layer of the base a layer of RTV106 (NC 7835.55.151) or equivalent.
3. Apply Loctite on the three first threads of the threaded holes in the base. Check the interoperability information in the appendix.



CAUTION

Always use Loctite 2701 to fasten the adapter ring on its support.



NOTICE

Refer to interoperability between light and base. Please find it in the appendix, [INTEROPERABILITY](#) section.

4. Mount the adapter ring onto the base and torque down the fixation screws.



CAUTION

Make sure the screws are tightened with the correct torque.

5. Install the light as described above.

5.0 Maintenance

This chapter describes general ideas on workshop maintenance and preventive maintenance and you will learn how to lift the unit out of the base or adapter ring. The servicing of the light assembly is described in detail in [Fixture and component related maintenance — detailed procedures](#) section.

Parts identification symbols (e.g. A1, B4, ...) appearing in the text refer to the [Exploded Views](#) section .

5.1 Overall maintenance — types and tasks

This sub chapter describes the general ideas on workshop maintenance and preventive maintenance. The servicing of the light assembly will be described in detail in sub chapter [Fixture and component related maintenance — detailed procedures](#).

5.1.1 In-the-field-maintenance

The light assemblies can be serviced in the field, but it is recommended to limit field maintenance to cleaning the prisms. It is recommended to replace the inset lights at regular intervals and to have them overhauled in the maintenance shop. The same applies to lights found non-serviceable in the field.

No specific tools are required to remove or re-install the fittings, except for the lifting tool (refer to [Lifting tools](#) section).

5.1.2 Preventive maintenance — Part 1

The assembly's service life depends to a large extent on its watertightness. All metal mating surfaces and seals must be clean, smooth, dry and free of all foreign particles if the light fixture is to operate for extended periods without requiring maintenance.

Greasing of O-ring seals may be required as indicated in this manual.

Preventive maintenance of the light fixtures should be performed as listed in the table on the next page.

Maintenance frequency depends on the conditions under which the runway is used (i.e. climate, traffic, etc.). The recommended practices for maintenance are described in the FAA advisory circular no. AC 150 / 5340-26 and in the ICAO Aerodrome Design Manual, Part 9 Airport Maintenance Practices.



For components mentioned in this chapter, refer to the [Screws Overview](#) section.

5.1.3 Preventive maintenance — Part 2

In the table below you will find a checklist of preventive maintenance tasks: In case lights are found to be defective during the warranty period, do not open them as explained below, but replace them by new units, and send the defective ones, unopened, to ADB SAFEGATE .

Table 1: Preventive maintenance tasks

Interval	Check	Action
Daily	for lamp failure	Replace lamp and film disc cut-out (if any).
	for low light output	<ol style="list-style-type: none"> 1. Clean outer surface of prism if dirty. 2. Check for misalignment or presence of moisture in fixture. 3. Check for lamp ageing or displacement
Weekly	for obstruction in light output channel	Clean channel and prism surface
Monthly ¹	for presence of moisture or water (visual inspection on condensation inside of prisms)	<ol style="list-style-type: none"> 1. Open up light assembly. 2. Clean, dry and inspect. 3. Replace O-ring and other parts found defective.

Table 1: Preventive maintenance tasks (Continued)

Interval	Check	Action
Bimonthly	torque on hold-down bolts	Refer to the How to mount the light assembly? section, for the tool to use. Please find the requirement for use of Loctite adhesives and the torque to apply in the appendix, INTEROPERABILITY section.
Semi-annually ²	for presence of water in base	<ol style="list-style-type: none">1. Pump water from base.2. Remove, dismantle and inspect light for water damage.3. Cure the cause of water ingress.
After 800 hours of operation at 6.6 A	Replace lamps of complete subsystem	It is recommended to replace the lamps systematically when 80 % of the useful life has been reached. At full brightness (6.6 A), it represents 800 hours, but, in practice, life spans of 2000 to 4000 hours can be expected.
After snow removal	for damaged light fixtures	<ol style="list-style-type: none">1. Replace badly damaged fixtures.2. Use a power broom for snow removal in the vicinity of the light fixture, if practical.3. Follow recommended snow removal techniques described in FAA AC 150/5200-30 to avoid or at least to reduce damage to light fixtures.

Notes

¹ More frequently during rainy seasons

² More frequently during rainy seasons.

5.2 Fixture and component related maintenance — detailed procedures

This chapter describes how to perform the various servicing tasks in the maintenance base.

All the screws used in this product are listed at the spare parts section of this manual.



Note

Refer to the [Screws Overview](#) section for the tool to use and the torque to apply.

5.2.1 How to lift the light assembly out of the base or adapter ring

5.2.1.1 Lifting tools

Beside the simple jig delivered with the standard tool case, ADB SAFEGATE has developed a more sturdy and efficient lifting tool (see illustration below). See [Accessories](#) section for references.

5.2.1.2 Lifting Procedure

To lift the optical unit out of the base receptacle or adapter ring, proceed as follows:

1. Remove the fixing screws and washers (A1-A2) or self locking nuts and discard them.
2. Fit the appropriate lifting tool into both holes located (180° apart) in the cover (B1), lift the optical unit out of the base or adapter ring and place it next to it.

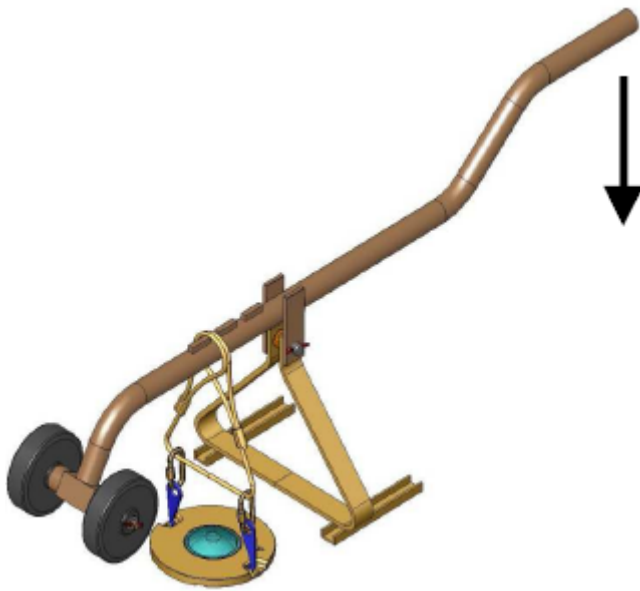

3. Disconnect the light fixture wires from the power wires coming from the transformer(s).
4. Remove the labyrinth gasket and discard it.
5. Mount a serviced or new fitting as described in or [Installation Procedure](#) section.
6. Take the optical unit back to the maintenance base where it can be serviced entirely.



CAUTION

Never hold the light fixture by the wires as this may damage the insulation, break the waterproof seal and cause insulation faults and water leakage.

5.2.2 How to open the light assembly

To open the light assembly, proceed as follows (for the tools to use, refer to [Screws Overview](#) section):

1. Turn the light unit upside-down. In order for the light to rest on a stable surface it is advised to lay it upside down on the top of a shallow base.

Figure 3: Light opening procedure 1



2. Remove the pressure release screw (F9).

Figure 4: Light opening procedure 2

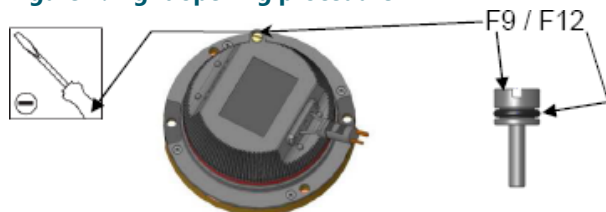

3. Remove the four screws (F4).

The use of an attack driver may be required to unlock the screws.

- Always use a new bit for each light requiring the use of an attack driver.
- Take care that the bit is well positioned on the screw head and that the driver is aligned with the axis of the screw.

Figure 5: Light opening procedure 3

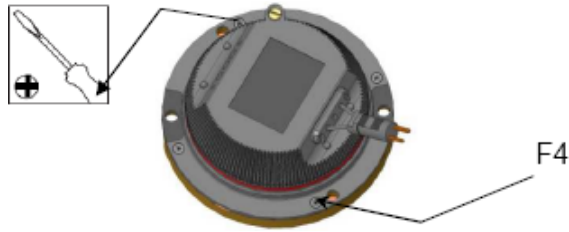

4. Introduce the special opening tool in the dedicated slot between cover and inner cover and rotate it to separate the inner cover from the cover.

Figure 6: Light opening procedure 4

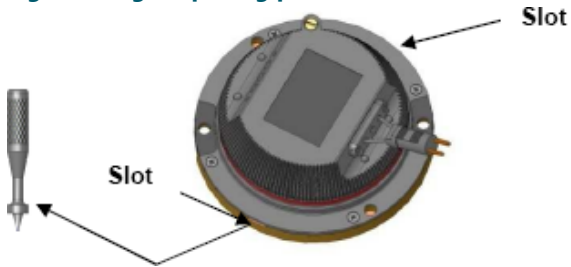

5.2.3 How to replace the lamp

5.2.3.1 Film disc cut-out

Remember

When used, always replace the film disc cut-out each time a lamp has to be replaced.

5.2.3.2 Lamp Replacement for FTO Taxiway

To replace a lamp, proceed as follows (for the tools to use, refer to [Screws Overview](#) section):

1. Lift the optical assy (E4) from the inner cover.
2. Unplug the lamps fast-on connectors from the terminal block (F1).

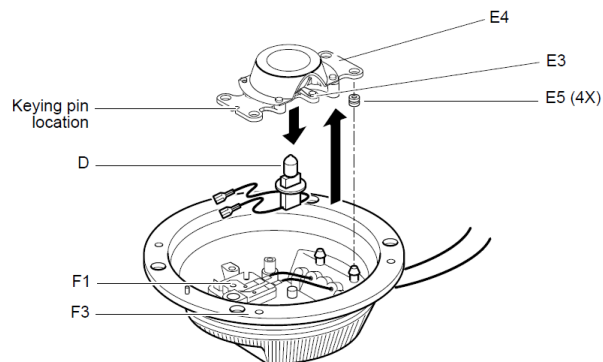

3. Pull out the lamp (D) from underneath; take care for the lamp spring (E3).
4. If a cut-out is used, remove it by loosening the screw which secures the cut-out clip to the terminal block and rotate cut-out clip free.

5. If a cut-out is used, position a new disc (small button side up) in the terminal block. Rotate the cut-out clip on top of the cut-out and hold while tightening the screw. Make sure that the pressure applied by the clip on the film disc is sufficient to assure good contact. If loosened, remove the clip and bend it slightly to increase its pressure.
6. Introduce a new lamp.



CAUTION

Never touch the bulb of the lamp with your bare fingers. It would reduce the lifetime of the lamp considerably. Should it happen, clean the bulb with methylated spirit.

7. Replace the dampers (E5) when damaged or aged and reinstall the optical assembly into the inner cover.



Note

Make sure there is good contact between fast-on connectors and terminals.

5.2.3.3 Lamp Replacement for FTO TLOF

To replace a lamp, proceed as follows (for the tools to use, refer to [Screws Overview](#) section):

1. Open the light assembly (as described in [How to open the light assembly](#) section).
2. Unplug the lamps fast-on connectors from the terminal block (F1).
3. Pull out the lamp (E3) from underneath, take care for the lamp spring (E6).

Figure 7: Lamp replacement 1

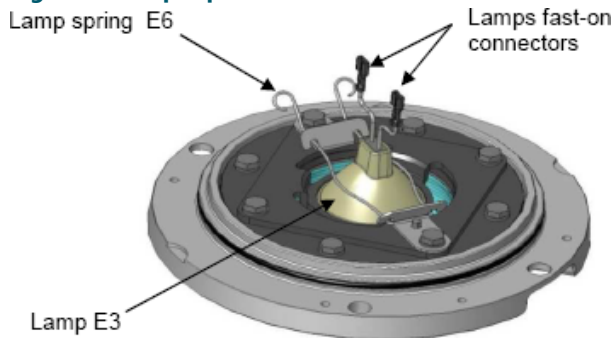

4. If a cut-out (F14) is used, remove it by loosening the screw which secures the cut-out clip to the terminal block and rotate cut-out clip free.
5. If a cut-out is used, position a new disc (small button side up) in the terminal block.

Rotate the cut-out clip on top of the cut-out and hold while tightening the screw. Make sure that the pressure applied by the clip on the film disc is sufficient to assure good contact. If loosened, remove the clip and bend it slightly to increase its pressure.

Figure 8: Lamp replacement 2

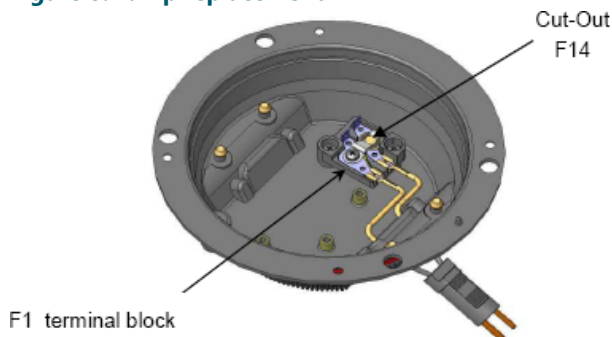

6. Introduce a new lamp and secure with the lamp spring (E6).



CAUTION

Never touch the bulb of the lamp with your bare fingers. It would reduce the lifetime of the lamp considerably. Should it happen, clean the bulb with methylated spirit.



NOTICE

Make sure there is good contact between fast-on connectors and terminals.

5.2.4 How to replace the outer lens

5.2.4.1 How to replace the lens for FTO Taxiway

To replace a lens, proceed as follows:

1. Unscrew the 8 screws (B6). Remove the washers and lockwashers.

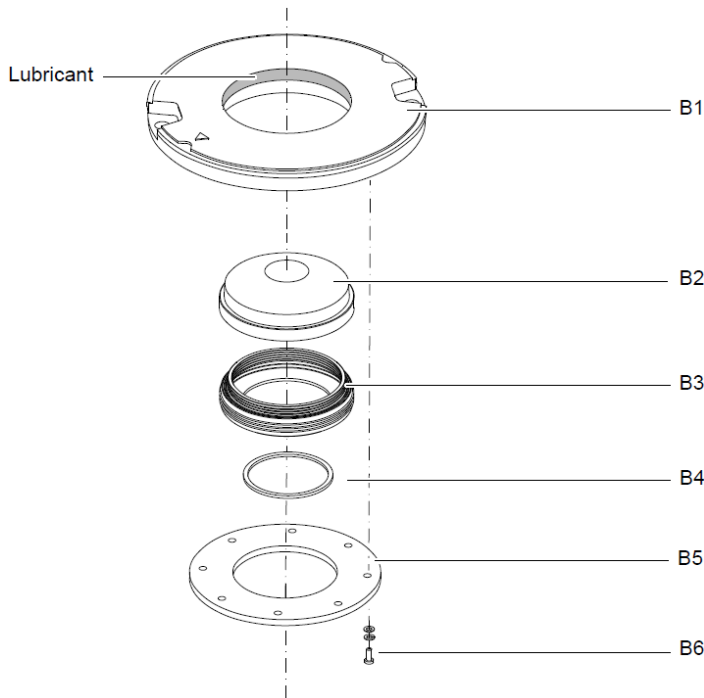

2. Remove the lens support plate (B5) and the lens gasket protection (B4).
 3. Push the lens (B2) with the lens gasket (B3) towards the inside of the cover (B1)
 4. Clean and degrease the lens chamber with any effective solvent.
-



CAUTION

Never use any abrasive substance.

Remnants of Loctite are present in the fixation holes of the screws B6. Clean them using a cleaning tap for blind holes (preferably use a tap with a right spiral groove) and blow with dry, oil-free compressed air.

5. Using a small brush, apply a thin layer of lubricant MOLYKOTE HP870 INERTA (ADB PN 7850.05.061) in the top section of the lens chamber of the cover (see in the figure above).
 6. Bring a new lens gasket (B3) over the lens.
-



CAUTION

Always replace the lens gasket (B3) and the 8 screws, washers and lock-washers (B6) by new ones when a lens is replaced. This to guarantee fixture water tightness.

7. Push the lens/ gasket assembly in the lens chamber from the inside, put the lens gasket protection (B4) and clean the inner surface of the lens.
8. Secure it to the cover by means of the lens support plate (B5) and 8 new screws (B6). Don't forget the washers and lock washers.



Note

Refer to the table "Screws Overview", page 42 for the tool to use and the torque to apply.

5.2.4.2 How to replace the outer lens for FTO TLOF

To replace a lens, proceed as follows:

1. Open the light assembly.
2. Unplug the lamps fast-on connectors from the terminal block (F1).
3. Pull out the lamp (E3) from underneath; take care for the lamp spring (E6).
4. Unscrew the 4 screws (E5).

Remove the lock washers.

Figure 9: Lens replacement

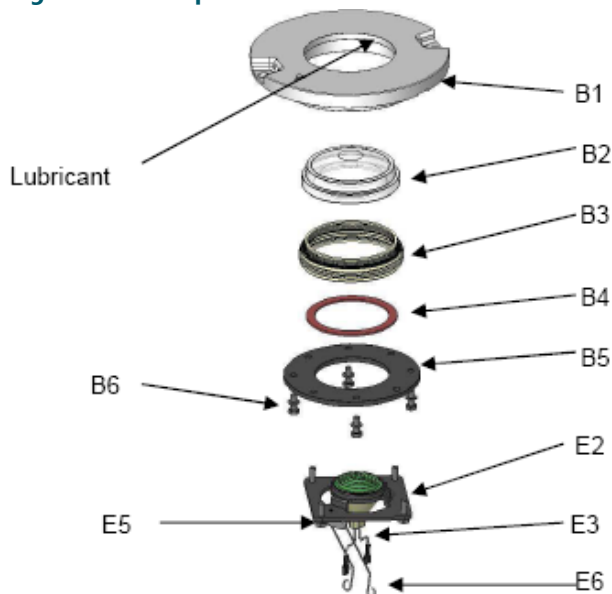

5. Remove the lamp support plate (E2) .
6. Unscrew the 4 screws (B6).
Remove the lock washers.
7. Remove the lens support plate (B5) and the lens gasket protection (B4).
8. Push the lens (B2) with the lens gasket (B3) towards the inside of the cover (B1).
9. Clean and degrease the lens chamber with any effective solvent.



CAUTION

Never use any abrasive substance.

Remnants of Loctite are present in the fixation holes of the screws B6. Clean them using a cleaning tap for blind holes (preferably use a tap with a right spiral groove) and blow with dry, oil-free compressed air.

10. Using a small brush, apply a thin layer of lubricant Molykote HP870 Inerta (PN 7850.05.061) in the top section of the lens chamber of the cover (see in the figure above).

11. Bring a new lens gasket (B3) over the lens.
-



CAUTION

Always replace the lens gasket (B3) and the 8 screw and lock-washers (B6, E5) by new ones when a lens is replaced.

This to guarantee fixture water tightness.

12. Push the lens/ gasket assembly in the lens chamber from the inside, put the lens gasket protection (B4) and clean the inner surface of the lens.
13. Secure it to the cover by means of the lens support plate (B5) and 4 new screws (B6).

Don't forget the lock washers.



Note

This is meant to guarantee fixture watertightness. Refer to the table in the [Screws Overview](#) section for the tool to use and the torque to apply.

14. Reinstall the lamp support plate (E2) by means of 4 new screws E5.

Don't forget the lock washers.



Note

Refer to the table in the [Screws Overview](#) section for the tool to use and the torque to apply.

15. Introduce the lamp (E3) and secure with the lamp spring (E6).
-



CAUTION

Never touch the bulb of the lamp with your bare fingers. It would reduce the lifetime of the lamp considerably. Should it happen, clean the bulb with methylated spirit.

5.2.5 How to replace the optical assembly

5.2.5.1 How to replace the optical assembly for FTO Taxiway

To replace the optical assembly, proceed as follows:

1. Remove the optical assembly (E4) by lifting it up, manually, from the inner cover (F3)

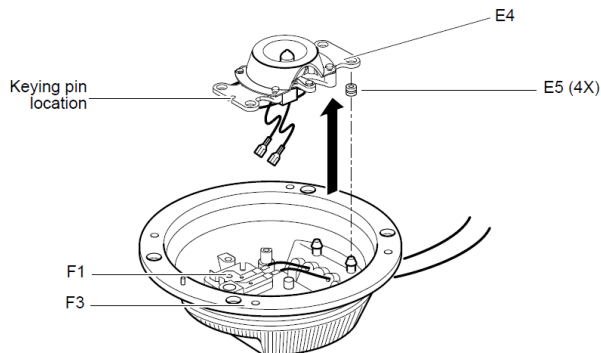

2. Unplug the lamps fast-on connectors from the terminal block (F1).
3. Replace the dampers (E5) when damaged or aged and proceed in reverse order.

5.2.5.2 How to replace the optical assembly for FTO TLOF

To replace the optical assembly, proceed as follows:

1. Open the light assembly as explained in [How to open the light assembly](#) section.
2. Unplug the lamps fast-on connectors from the terminal block (F1).

Figure 10: Optical assembly replacement procedure

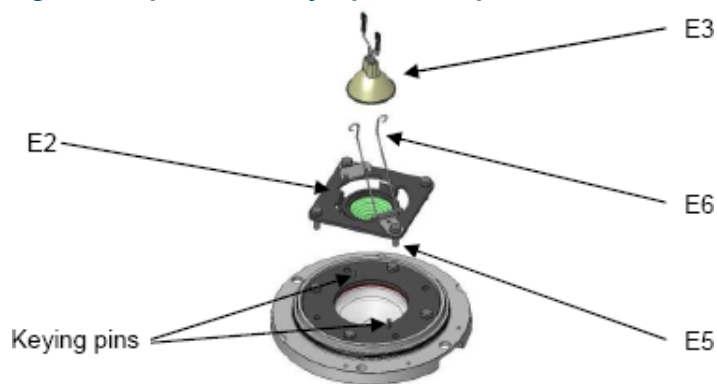

3. Pull out the lamp (E3) from underneath; take care for the lamp spring (E6).
4. Unscrew the 4 screws (E5).
Remove the lock washers.
5. Remove the lamp support plate assembly (E2) with sealed inner lens.
Remnants of Loctite are present in the fixation holes of the screws E5. Clean them using a cleaning tap for blind holes (preferably use a tap with a right spiral groove) and blow with dry, oil-free compressed air.
6. Reinstall a new support plate assembly (E2) by means of 4 new screws E5.
Respect the keying pins and don't forget the lock washers.



Note

Refer to the table in the [Screws Overview](#) section for the tool to use and the torque to apply.

7. Introduce the lamp (E3) and secure with the lamp spring (E6).



CAUTION

Never touch the bulb of the lamp with your bare fingers. It would reduce the lifetime of the lamp considerably. Should it happen, clean the bulb with methylated spirit.

5.2.6 How to replace the cable set assembly

5.2.6.1 Cable sets

Restriction

Only use ADB SAFEGATE cable sets. Usage of substitutes voids the warranty.

5.2.6.2 Cable Replacement

To replace the cable set assembly, proceed as follows:

1. Open the light assembly as explained in the [How to open the light assembly](#) section).
2. Remove both screws (F7) and the wire clamp (F6).

Figure 11: Cable assembly replacement

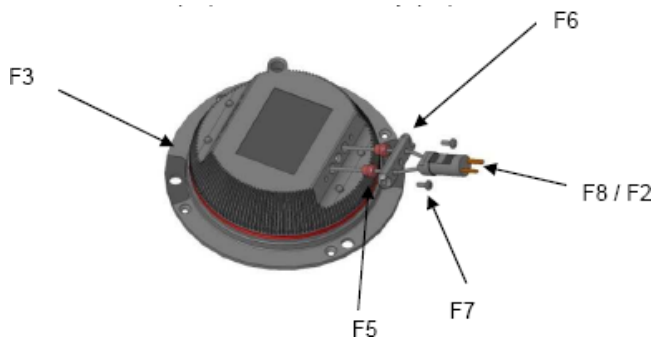

3. Cut the fast-on connectors (F2) from the cable assembly (F8).
 4. Pull the cable assembly out of the inner cover and discard the grommets (F5).
 5. Bring the new ADB SAFEGATE cable assembly through the wire clamp (F6)
-



CAUTION

Use only one wire per hole.



NOTICE

Only use ADB SAFEGATE cable sets. Usage of substitutes voids the warranty.

6. Put a new wire grommet (F5) on each of the wires, taking care of the direction (the smaller diameter into the inner cover recesses).
 7. Introduce the wires in the inner cover (F3).
 8. Reinstall the wire clamp (F6) by means of both screws (F7).
Do not torque down the screws entirely at this step.
 9. Remove the insulation of the wires over about 5 mm.
 10. Crimp on new fast-on connectors (F2- ADB CN 6111.87.140) and connect to the terminals.
Adjust the wires inside the inner cover.
 11. Torque the screws (F7).
-



Note

Refer to the table in the [Screws Overview](#) section for the tool to use and the torque to apply.

5.2.7 How to close and test the light fixture

Important

Always replace cover / inner cover gasket and fixing screws by new ones!

To close an optical unit, proceed as follows:

1. Turn the cover (B1) upside down.

In order for the cover to rest on a stable surface it is advised to lay it upside down on the top of a shallow base.

Figure 12: Closing procedure 1



2. Make sure that the contact surfaces with the O-ring are clean.

Remnants of Loctite may be present in the fixation holes of the screws F4. Clean them using a cleaning tap for blind holes (preferably use a tap with a right spiral groove) and blow with dry, oil-free compressed air.

3. Put a new O-ring gasket (B8) greased with high quality neutral silicone grease (PN 7850.42.210) over the cover in the appropriate groove.
4. Remove the pressure release screw (F9).

Figure 13: Closing procedure 2

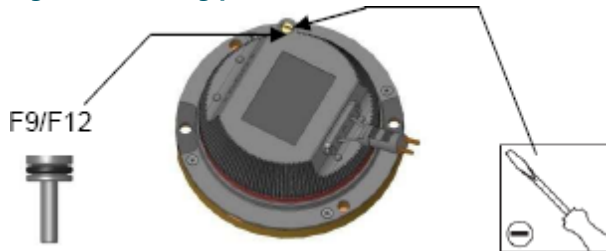

5. Gently put the inner cover (F3) on top of the cover, taking into account the keying pin between both parts.

Make sure the optical assembly (F14) and the lamp (E3) are correctly positioned and that the wires do not get damaged between both parts: cover (B1) and inner cover (F3).

6. Press the inner cover (F3) on the cover (B1) and secure with new screws (F4).



Note

Refer to the table in the [Screws Overview](#) section for the tool to use and the torque to apply.

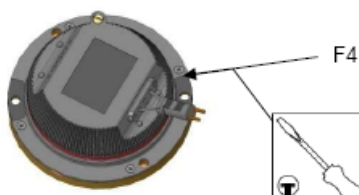

7. Check electrical insulation from two-pole plug to frame by means of a 500V insulation tester.

Apply an AC or DC voltage not exceeding 6 V across the two-pole plug and observe normal operation of the lamp.

8. Check watertightness of the fitting by applying with dry air a pressure of 0.4 bar (40 kPa) above the atmospheric pressure via the pressure release hole.

Whilst pressure is applied, immerse the light fixture for three minute in water and look carefully for NO stream of bubbles emanating from the light fixture.

If no leakage occurs, dry the fixture and remove the air hose.

Else, locate the leak source. Dry the fixture, remove the air hose. Replace the leaking gasket or part (check the contact surfaces for any scratches, corrosion or other damage) and repeat the test.

For this purpose a watertightness test adapter can be ordered from ADB SAFEGATE (see ordering code in the [Spare parts](#) chapter).

9. Replace the O-ring seal of the pressure release screw (F9) and secure the pressure release screw.



Note

Refer to the table in the [Screws Overview](#) section for the tool to use and the torque to apply.

5.3 Product Troubleshooting

In the table below a number of problems are listed in the first column. In the second column, you will find the possible causes of the problem and in the third column the solution.

Table 2: Troubleshooting table

Problem	Possible cause	Solution
Light does not energize.	Lamp defective	1. Replace lamp. 2. Replace film disc cut-out (when used).
	Loose or broken contacts	Tighten or replace the contacts.
	Moisture inside assembly causing current leakage	1. Open light assembly. 2. Clean, dry, inspect or replace damaged components.
	Defective cable assembly or defective crimping	1. Open light assembly. 2. Replace cable assembly.
	Defective isolation transformer or secondary wiring	Check transformer output current with Am meter. Check power line between the light fixture and the transformer, including connectors.
Light does not energize at normal level.	Resistance too high or partial short circuit. Dirty lens. Defective isolation transformer.	1. Replace cable assembly or inner cover assembly. 2. Replace lamp and/or transformer. 3. Clean lens.
	Wrong fitting	Replace fitting with one of the proper color.

Table 2: Troubleshooting table (Continued)

Problem	Possible cause	Solution
Short lamp life	Too high current (lamp will have black burns)	Check output current of isolating transformer at full brightness. Current should not exceed 6.7 A. Replace transformer if defective; if not, adjust CCR output current.
	Moisture in assembly	1. Open light assembly. 2. Clean, dry, inspect or replace damaged components.
	Defective lamp or lamp bulb touched with bare fingers (lamp interior will have a yellow-white powdery appearance if air has entered through a hole or crack)	1. Replace lamp. 2. If used, replace film disc cut-out.

5.4 Accessories

In the lists below you will find useful accessories for the installation, maintenance and repair of the FTO light.

5.4.1 Tool case

ADB SAFEGATE has designed a tool case (part number **1411.19.421**) including the basic tools necessary for the maintenance of inset lights. It can also be used for the installation of the light fixture (please note this is a general tool case, some tools are of no use for FTO lights). The table below lists the tools included in the case:

Table 3: Maintenance tools overview

Description	Part Number	Description	ADB Part Number
Tool case	6169.01.007	Screwdriver, flat blade AG. 8x150	8961.05.250
Torque wrench	8961.06.255	Screwdriver, Pozidriv AD.2x125	8961.05.220
Socket hex 3/8", screw 3/8", J 9/16LA	8961.06.008	Loctite 2701	7870.05.130
Socket hex 3/8", screw M10, J 17LA	8961.06.000	Loctite 222	7870.05.140
Socket, 1/4", 1.6x8 Flat, RS.8E	8961.05.050	Lubricant Molykote HP870 Inerta (100 gr) (to replace lens)	7850.05.061
Socket, 1/4", Pozidriv2, RD.2	8961.05.060	Natural hydraulic vacuum silicone grease	7850.42.220
Extension, 1/4", R.210	8961.06.220	Attack driver	8961.04.100
Adaptation, 1/4"-3/8", R.232	8961.06.010	Hammer 212A50	8961.04.110
Hinged handle - short	8961.06.110	Bit holder	8961.04.120
Plier	8981.10.110	Bits END202, Pozidriv2	8961.04.130
Opening tool	4071.53.220	Lifting tool assembly for inset lights	1411.19.550
Screwdriver ANX25x100 TX20	8961.05.300	Bit Torx 1/4" - TX20 EX.620 L=70mm	8961.06.020
Screwdriver ANX25x100 TX25	8961.05.290	Bit Torx 1/4" - TX20 EX.625 L=70mm	8961.06.025

5.4.2 Additional accessories

The following accessories can be purchased separately:

Table 4: Additional accessories overview

Description	ADB Part Number
Watertightness test adapter for inset lights	4060.84.570
Set of spare anchor hooks for lifting tool 1411.19.550	1411.19.560
Lifting tool on wheels (refer to Lifting Procedure)	1420.55.600

5.4.3 Fixing Elements

The fixing hardware for securing the fitting on to the mounting interface is generally not supplied with the fitting as it depends on the exact type of mounting interface. It can be purchased as kits or loose components, as listed in [Fixing Hardware Kits for Runway, Taxiway and Heliport Use](#) section.

6.0 Spare parts

In this chapter you will find an overview of the main and sub-assemblies and the exploded views of the 8-inch F-RANGE FTO inset light. References of the types of products described in this manual, of their spare parts and accessories are listed in this chapter, together with exploded views.

Tip

It is recommended to create a sufficiently large stock of spare parts to maintain the fittings. It will mainly consist of consumables like lamps, O-ring gaskets, film disc cut-outs, etc. Other components that may need replacement, such as prisms, prism gaskets, terminal blocks and hardware even as sub-assemblies should be stocked in smaller quantities. The stock should also contain some complete fittings of each type.

6.1 Exploded Views

6.1.1 Exploded View Standard FTO

The illustration below represents the exploded view of a FTO inset light:

Figure 14: FTO light exploded view

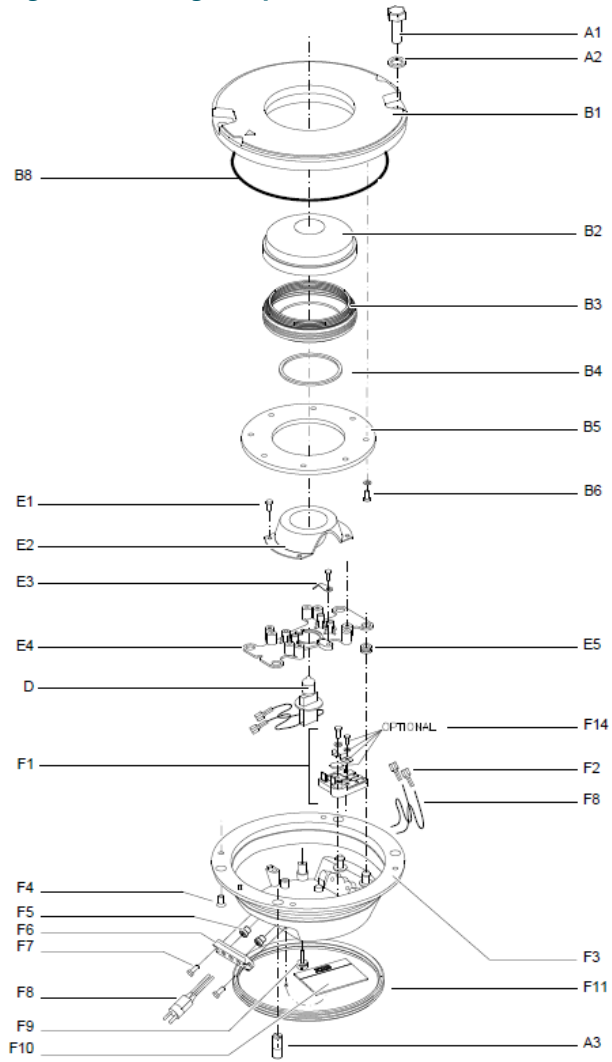

6.1.2 Exploded View Special Version TLOF

The illustration below represents the exploded view of a FTO TLOF inset light:

Figure 15: FTO TLOF light exploded view

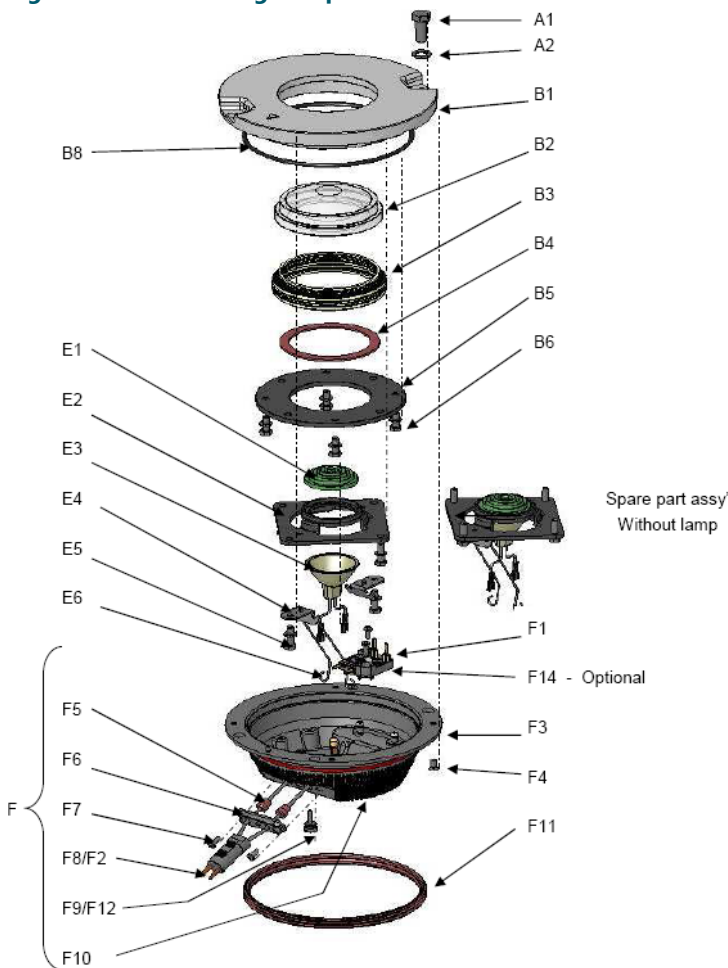

6.2 Complete Fixtures and Components

6.2.1 Fixtures and Main Assemblies of the FTO Taxiway and FTO TLOF Inset Lights

In the table below you will find all fixtures and main assemblies of the FTO Taxiway inset lights:

Table 5: Fixtures and main assemblies of FTO Taxiway and FTO TLOF inset lights

Category	Description	Fixtures		Main assemblies (spare parts)		
		Ordering code	Code	Cover	Optical assy	Inner cover
FTO	white	FTO-3-065-0-C-0	1TOA21001103	1411.20.600	1411.22.100	1411.23.020
	red	FTO-3-045-0-R-0	1TOA12001103	1411.20.610	1411.22.100	1411.23.020
	blue	FTO-3-045-0-B-0	1TOA15001103	1411.20.630	1411.22.100	1411.23.020
	yellow	FTO-3-065-0-Y-0	1TOA24001103	1411.20.620	1411.22.100	1411.23.020
TLOF	Green	FTO-3-048-0-G-0	1TOA33001103	1411.20.650	1411.22.110	1411.24.520

**Note**

Complete lights are delivered **without fixing hardware**. This hardware is delivered together with the mounting system (base or adapter ring), or can be ordered separately (see [Fixing hardware kits heliport](#) section).

6.2.2 FTO Taxiway Cover and Optical Assembly Parts

In the table below you will find the FTO Taxiway cover and optical assembly parts and their availability as spare part or not; in the latter case, order the complete light (see [Fixtures and Main Assemblies of the FTO Taxiway and FTO TLOF Inset Lights](#)):

Table 6: Components of the FTO Taxiway covers and optical assemblies

No.	Spare part number	Description	1411.20.xxx			
			600	610	620	630
B1	SP4071.76.003	FTO cover machined	1	1	1	1
B2	SP010572	FTO lens clear	1			
B2	SP010573	FTO lens red		1		
B2	SP010574	FTO lens yellow			1	
B2	SP010575	FTO lens blue				1
B3	SP4071.76.041 (20 pcs)	FTO lens gasket	1	1	1	1
B4	SP4071.76.060 (20 pcs)	FTO lens gasket protection				
B5	SP4071.76.020 (10 pcs)	FTO lens support	1	1	1	1
B6	SP7100.08.563 (100 pcs)	HEX SCREW M6x16 DIN 933- A2-LOCK 2045	8	8	8	8
	SP7284.10.445 (100 pcs)	Lockwasher M6 Stainless steel - DIN 7980	8	8	8	8
B8	SP7080.90.335 (10 pcs)	O-ring gasket between cover and inner cover	1	1	1	1

No.	Spare part number	Description	1411.22.100
D	SP010706 (10pcs)	Prefocus halogen lamp 45 W - 6.6 A - 1000 hrs	1
D	SP010707 (10 pcs)	Prefocus halogen lamp 65 W - 6.6 A - 1000 hrs	1
E1	SP7110.08.360 (100 pcs)	Screw THRD M4X10 Stainless Steel	4
E2	SP4071.76.031 (10 pcs)	FTO reflector	1
E3	SP4071.50.581 (10 pcs)	Lamp spring	1
E4	SP4071.50.482 (10 pcs)	Reflector/ lamp support	1
E5	SP010736 (100 pcs)	Vibration damper grommet	4

6.2.3 FTO TLOF Cover and optical Assembly Parts

In the table below you will find the FTO TLOF cover and optical assembly parts and their availability as spare part or not; in the latter case, order the complete light ([Fixtures and Main Assemblies of the FTO Taxiway and FTO TLOF Inset Lights](#) section):

Table 7: Components of the FTO Taxiway covers and optical assemblies

No.	Spare part number	Description	Components per fitting
B1	SP.4071.76.003	FTO cover machined	1
B2	SP.1428.00.445 (10 pcs)	Clear outer lens for TLOF	1
B3	SP.4071.76.041 (20 pcs)	FTO lens gasket	1
B4	SP.4071.76.060 (20 pcs)	FTO lens protection gasket	1
B5	SP.4071.76.020 (10 pcs)	FTO lens support	1
B6	SP.7100.08.563 (100 pcs)	HEX SCREW M6x16 DIN 933-A2-LOCK 2045	4
	SP.7284.10.445 (100 pcs)	Lockwasher M6 Stainless steel - DIN 7980	4
B8	SP.7080.90.335 (10 pcs)	O-ring gasket between cover and inner cover	1

Table 8: Optical assemblies overview

No.	Spare part number	Description	Components per fitting
E	1411.22.110	Optical assy TLOF	-
E1	SP.1428.00.390 (10 pcs)	TLOF Inner lens green	1
E2	SP.4072.13.630 (10 pcs)	TLOF Inner lens and lamp support	1
E3	SP.011851 (10 pcs)	Cold mirror prefocus halogen lamp 48W 6.6A - 1500h	1
E4	SP.4072.13.611 (10 pcs)	Lamp support clamp	2
E5	SP.7100.08.571 (100 pcs)	SCREW TH M6 20 DIN933-A2-LOCK 2045	4
	SP.7284.10.445 (100 pcs)	Lockwasher M6 Stainless steel - DIN 7980	4
E6	SP.4072.13.600 (10 pcs)	Spring for lamp	1

6.2.4 FTO Taxiway and FTO TLOF inner Cover Assembly Components

In the table below you will find the FTO inner cover assembly components and their availability as spare part or not; in the latter case, order the complete inner cover assembly (see [Fixtures and Main Assemblies of the FTO Taxiway and FTO TLOF Inset Lights](#) section):

Table 9: Components of the FTO Taxiway and FTO TLOF inner covers assemblies

No.	Part Number	Description	1411.23.020 1411.24.520
F1	1411.21.010	Terminal block assembly with fixing hardware and w/o cut-out	1
F1	1411.21.000	Terminal block assembly with fixing hardware and film disc cut-out	opt.
F2	SP013068 (100 pcs)	Female fast-on connector	2
F3	SP4071.50.083	Inner cover machined for one cable inlet	1
F4	SP7100.10.190 (100 pcs)	SCREW M5x10 DIN 965-T-A2-LOCK 2045	4
F6	SP010762 (100 pcs)	Wire clamp	1
F7	SP7100.08.360 (100 pcs)	SCREW M4x10 DIN 7500CE-T-A2	2
F8	SP013033 (5pcs)	FAA L-823 2-pole plug moulded on heat resistant 30 cm wires 1.9 mm ² STY6	1
F9	SP010869 (10pcs)	Pressure release screw assembly including O-ring seal	1
F10		name plate	1
F11	Refer interoperability matrix	labyrinth gasket	1

6.3 Fixing hardware kits

In the table below you will find the fixing kits of 8" and 12" F-Range inset lights: The choice for hardware kit depends on several criteria : the used thread in the base (metric or UNC), the use of screws or studs and the base itself (refer to interoperability matrix)

Table 10: Fixing hardware kits of F-Range inset lights

METRIC FIXING HARDWARE KITS								
Fixing hardware kit		Components						
Description	Part Number	7100.08.759 St.Steel Screw M10 X25	7150.53.320 St. Steel Nut M10	7150.53.330 St.St.Steel Self-locking Nut M10 H100	7150.53.335 St.St. Self-locking Nut M10 H80	7284.10.470 St. Steel Lock Washer M10	7284.70.345 Nylon Encap. Washer M10	4071.50.240 Metric Anti-Rotation Pin
For mounting 8" inset lights on to 8" shallow bases or adapter rings								
Metric screw kit 8" (with anti-rotation pins)	1411.20.400	2				2		2
Metric nut kit 8"	1411.20.420		2			2		
Self-locking metric nut kit 8 (H100)"	1411.20.430			2				
Self - locking metric nut kit 8" (H80)	1411.20.435				2			
Metric screw kit 8" (Germany)	1411.20.441	2					2	
Metric screw kit 8" (w/o anti-rotation pins)	1411.20.522	2				2		
For mounting 12" inset lights or adapter rings on 12" shallow or deep bases								
Metric screw kit (France) 12"	1411.20.482	6				6		
Metric screw kit 12" (Germany)	1411.20.492	6					6	
Self-locking nut kit 12" (H100)	1411.20.500			6				
Self-locking metric nut kit 12" (H80)	1411.20.505				6			

Notes

¹ **Note (1): HPI bases only accept Metric hardware**

UNC FIXING HARDWARE KITS							
Fixing hardware kit			Components				
Description	Part Number						
		7200.13.806 St. St. Screw 3/8" - 16 UNC	7284.10.470 St. Steel Lock Washer M10	4027.50.120 UNC Anti-Rotation Pin			
For mounting 8" inset lights on 8" shallow bases or adapter rings							
UNC screw kit 8"	1411.20.411	2	2	2			
For mounting 12" inset lights or adapter rings on 12" shallow or deep bases							
UNC screw kit 12"	1411.20.452	6	6				

6.4 Screws Overview

The table below gives for each screw used in this product, the reference on the exploded view, the type of screw, the tool to use and the torque.

Screws used in the FTO Taxiway light

The table below gives for each screw used in this product, the reference on the exploded view, the type of screw, the tool to use and the torque.

Table 11: Screws and references

Screw	Tool	Torque
A1 (not supplied with the light) Screw FT.HEX M10 x 25, SST, Hex Head or Screw FT.HEX 3/8"-16UNC X7/8"	Socket hex 17mm or Socket hex 9/16"	Refer to the appendix, INTEROPERABILITY section.
B6 -7100.08.563 - HEX SCREW M6x16 DIN 933-A2-LOCK 2045	Socket head 10mm	3.5 Nm / 31 Lb.in
E1(FTO Taxiway),F7 - 7100.08.360 - SCREW M4x10 DIN 7500CE-T-A2	Torx20	3.5 Nm / 31 Lb.in
F4 - 7100.10.190 - SCREW M5x10 DIN 965-T-A2-LOCK 2045	Torx25	2.5 Nm / 23 Lb.in
F9 - Pressure release screw	1.6 x 8 Flat	2.5 Nm/ 23 Lb.in
Self-locking nut (M10)	Socket hex 17mm	Refer to the appendix, INTEROPERABILITY section.
Screws delivered for installation of adapter ring on deep base	Socket hex 17mm or Socket hex 9/16"	Refer to the appendix, INTEROPERABILITY section.

6.5 Addendum FTO 230V

Figure 16: Addendum — Profile

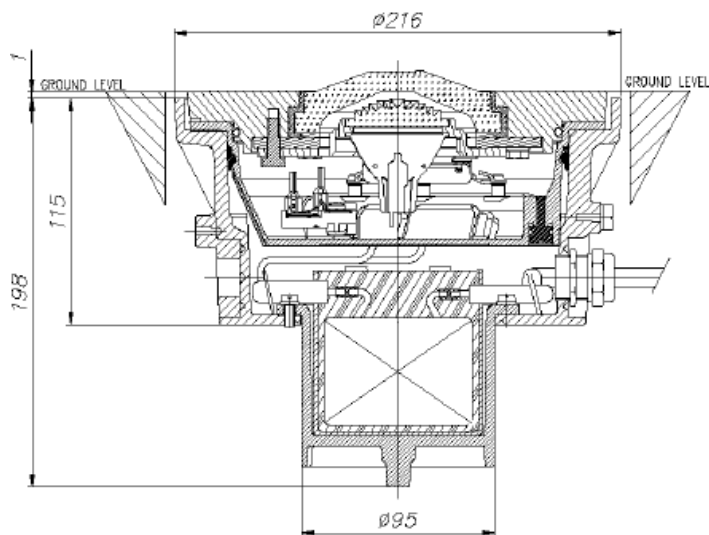
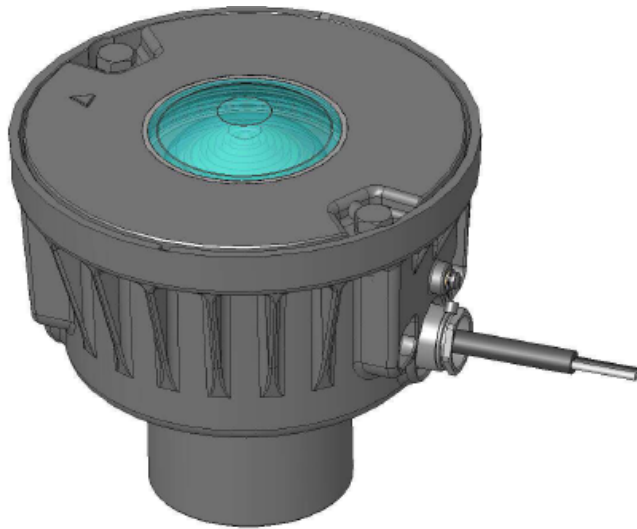
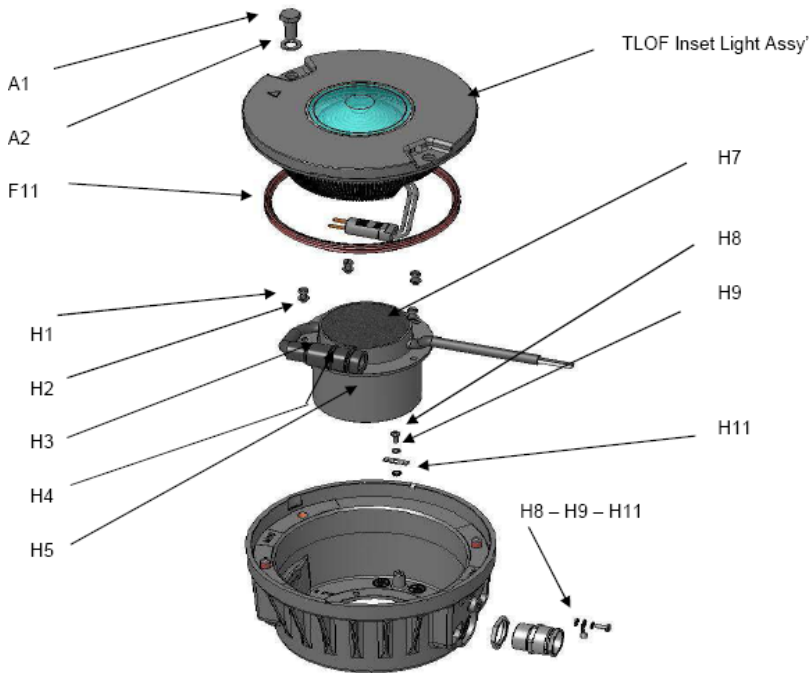

Figure 17: Addendum — Exploded View



NO	Description	Part Number	Order quantity
H1	Screw M5 x 12 - Stainless steel	7110.08.428	100
H2	Lock washer M5 - Stainless steel	7284.10.428	100
H3	Connector kit	PAK3RB500001	1
H4	Sealing	7870.05.120	1
H5	Transformer support	4071.86.360	1
H7	Transformer 230V to 7,27 V	4072.14.460	1
H8	Taptite screw M4 x 10 - Stainless steel	7110.08.400	
H9	Lock washer M4 - Stainless steel	7284.10.416	
H11	Contact washer M4	7284.40.250	

Appendix A: INTEROPERABILITY

ADB SAFEGATE Interoperability

Table 12: Interoperability matrix

Base type	Required O-ring	Bolt installation		Stud installation	
		Required dimension	Recommended torque	Required nut	Recommended torque
ADB 8" Eurobase; ADB 8" HPI; Adapter ring ADB 8" to 12"	White labyrinth gasket 4072.76.560 / 10 pcs 4072.76.570 / 100 pcs	1411.20.522 Metric screw kit 25 mm	21 Nm + Loctite 2701	1411.20.430 Self-locking nut kit H100	21 Nm + Loctite 2701
ERNI 8" ED08-133	Red labyrinth gasket 4072.76.580 / 10 pcs 4072.76.590 / 100 pcs	1411.20.522 Metric screw kit 25 mm	21 Nm + Loctite 2701	1411.20.435 Self- locking nut kit H80	21 Nm + Loctite 2701



Note

Contact your ADB SAFEGATE Sales representative for more information.

Appendix B: POWER TABLE

F-RANGE 8-inch FTO Taxiway inset Fixtures – Power Table Runway and Taxiway

Fixture type	Fixture load	Isolation transformer			CCR load
		Rating	Loss	Efficiency	
FTO (omnidirectional)	48 VA	45 W	9 VA	0.85	57 VA
FTO (omnidirectional)	65 VA	65 W	11 VA	0.85	76 VA
FTO (omnidirectional)	45 VA	45 W	8 VA	0.85	53 VA

F-RANGE 8-inch FTO inset Fixtures – Power Table Heliport

Fixture type	Fixture load	Isolation transformer			CCR load
		Rating	Loss	Efficiency	
FTO - TLOF (omnidirectional)	48 VA	45 W	9 VA	0.85	57 VA
FTO - FATO (omnidirectional)	65 VA	65 W	11 VA	0.85	76 VA
FTO - FATO (omnidirectional)	45 VA	45 W	8 VA	0.85	53 VA
FTO – aiming point (omnidirectional)	45 VA	45 W	8 VA	0.85	53 VA

Explanation to power table

Lamp: 45W, 65W (6.6A PKX30D Halogen lamp), 48W (cold mirror prefocus halogen lamp).

Color	Lamp power		
	45 W	48 W	65 W
White	x	-	x
Yellow	x	-	x
Green	-	x	-



Note

- Deep base and / or adapter rings to be ordered separately.
- Use of a cutout is not compatible with the *Lamp Fault Detection (LFD)* functionality of a regulator.
- Special execution for heliports with 230 V 50/60 Hz parallel supply: 65 W / white 1T0A21001900; 65 W / red 1T0A22001900 and 65 W / yellow 1T0A24001900

For detailed information, please refer to the mounting instructions supplied with the FTO.

The ADB SAFEGATE technical team is at disposal of users and contractors to provide guidance and advice in order to help solving any particular installation problem.

Appendix C: CABLE LOSS

The cable resistance R (Ohms) for 1 conductor is calculated with following formula:

- $R \text{ (Ohms)} = \text{resistivity of material (Ohm m)} * \text{Length (m)} / \text{cross sectional area (m}^2\text{)}$
- for copper conductors the resistivity is $1.72 \cdot 10^{-8} \text{ (m}^2\text{)}$

For example for 1km 2.5 mm² copper cond., the resistance R is calculated like this:

$$1.72 \cdot 10^{-8} * 1000 / 2.5 \cdot 10^{-6} \text{ m}^2 = 6.88 \text{ Ohms}$$

The loss (Watt) is then $R * I^2$ or $6.88 \text{ Ohms} * 6.6^2 \text{ A}^2 = 299.69 \text{ W} / \text{km}$ or $0.299 \text{ W} / \text{m}$.

The loss (Watt) for a secondary cable with 2 conductors is thus $2 * 0.299 = 0,599$ or $0,6 \text{ W} / \text{m}$.

As such we can calculate:

- for a 2.5 mm² Cu-wire (2 conductors) : $0.6 \text{ W} / \text{m}$
- for a 4 mm² Cu-wire (2 conductors) : $0.4 \text{ W} / \text{m}$
- for a 6 mm² Cu-wire (1 conductor): $0,12 \text{ W/m}$

The cable between the isolation transformer and the lamp adds losses that cannot be ignored when dimensioning the circuits and selecting rating for secondary transformers and regulators.



NOTICE

Secondary cable lengths should not exceed 100 m.

For a secondary cable of e. g. 20 m of 2.5 mm² CU-wire, $20 \text{ m} * 0.6 \text{ W} / \text{m} = 12 \text{ W}$ equals the additional loss to be taken into account.

For a primary cable of e. g. 100 m of 6mm² CU-wire, $100 \text{ m} * 0,12 \text{ W} / \text{m} = 12 \text{ W}$ equals the additional loss to be taken into account.

Appendix D: SUPPORT

Our experienced engineers are available for support and service at all times, 24 hour/7 days a week. They are part of a dynamic organization making sure the entire ADB SAFEGATE is committed to minimal disturbance for airport operations.

ADB SAFEGATE Support

Live Technical Support - Americas

If at any time you have a question or concern about your product, just contact ADB SAFEGATE's technical service department. Trained in all areas of system issues, troubleshooting, quality control and technical assistance, our highly experienced Technical support specialists are available 24 hours a day, seven days a week to provide assistance over the phone.

ADB SAFEGATE **Americas Technical Service & Support (US & Canada): +1-800-545-4157**

ADB SAFEGATE Americas Technical Service & Support (International): +1-614-861-1304

During regular business hours, you can also Chat with a Service Technician. We look forward to working with you!

Before You Call

When you have an airfield lighting or system control system problem it is our goal to support airfield maintenance staff as quickly as possible. To support this effort we ask that you have the following information ready before calling.

- The *airport code*
- If not with an airport, then company name (prefer customer id number)
- Contact phone number and email address
- Product with part number preferable or product number
- Have you reviewed the product's manual and troubleshooting guide
- Do you have a *True RMS* meter available (and any other necessary tools)
- Be located with the product ready to troubleshoot

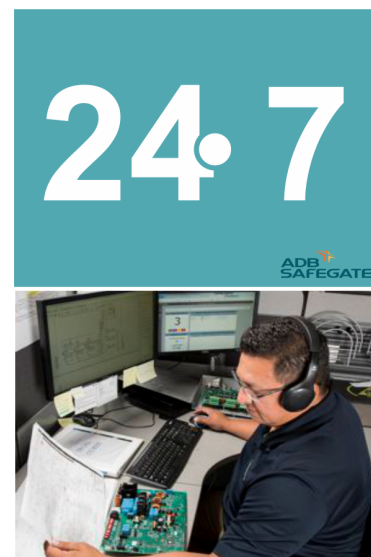

Note

For more information, see www.adbsafegate.com, or contact ADB SAFEGATE Support via email at support@adbsafegate.com or

Brussels: +32 2 722 17 11

Rest of Europe: +46 (0) 40 699 17 40

Americas: +1 614 861 1304. Press 3 for technical service or press 4 for sales support.

China: +86 (10) 8476 0106

D.1 Telephoning Customer Service

When you call for technical assistance, you should have the appropriate product documentation at hand. Be prepared to give the following information:

- To what product does the question relate?
- The exact wording of any messages that appeared on the Operator Interface screens (Computer System related assistance only).
- What happened, and what you were doing before and during when the problem occurred.
- How have you tried to solve the problem.

D.2 ADB SAFEGATE Website

The ADB SAFEGATE website, www.adbsafegate.com, offers information regarding our airport solutions, products, company, news, links, downloads, references, contacts and more.

D.3 Disposal

Tip

You can also contact the customer service team to get information on adequate disposal options or recycling of electrical devices delivered by .



NOTICE

Electrical equipment that is not in use or needed anymore, must be disposed according to the applicable legal environmental regulations. Electrical must not be disposed with household waste. Follow the applicable regulations established by the responsible local authorities. Contact the responsible local authorities for more information on local waste disposal sites or recycling centers.

D.4 Recycling

D.4.1 Local Authority Recycling

The disposal of ADB SAFEGATE products is to be made at an applicable collection point for the recycling of electrical and electronic equipment. The correct disposal of equipment prevents any potential negative consequences for the environment and human health, which could otherwise be caused by inappropriate waste handling. The recycling of materials helps to conserve natural resources. For more detailed information about recycling of products, contact your local authority city office.

D.4.2 ADB SAFEGATE Recycling

ADB SAFEGATE is fully committed to environmentally-conscious manufacturing with strict monitoring of our own processes as well as supplier components and sub-contractor operations. ADB SAFEGATE offers a recycling program for our products to all customers worldwide, whether or not the products were sold within the EU.

ADB SAFEGATE products and/or specific electrical and electronic component parts which are fully removed/separated from any customer equipment and returned will be accepted for our recycling program.

All items returned must be clearly labeled as follows:

- For *ROHS/WEEE* Recycling
- Sender contact information (Name, Business Address, Phone number).
- Main Unit Serial Number.

ADB SAFEGATE will continue to monitor and update according for any future requirements for *EU directives* as and when *EU member states* implement new *regulations* and or *amendments*. It is our aim to maintain our *compliance plan* and assist our customers.

Company Addresses

ADB SAFEGATE, Belgium	ADB SAFEGATE BV Leuvensesteenweg 585, B-1930 Zaventem Belgium
Contact: Tel.: +32 2 722 17 11 Fax: +32 2 722 17 64	Email: marketing@adbsafegate.com Internet: www.adbsafegate.com
ADB SAFEGATE, Americas	ADB SAFEGATE Americas LLC 977 Gahanna Parkway, Columbus, OH 43230 USA
Contact: Tel.: +1 (614) 861 1304 Fax: +1 (614) 864 2069	Email: sales.us@adbsafegate.com Internet: www.adbsafegate.com
ADB SAFEGATE, Sweden	ADB SAFEGATE Sweden AB Djurhagegatan 19 SE-213 76 Malmö Sweden
Contact: Tel.: +46 (0)40 699 17 00 Fax: +46 (0)40 699 17 30	Email: marketing@adbsafegate.com Internet: www.adbsafegate.com
ADB SAFEGATE, China	ADB SAFEGATE Airfield Technologies Ltd. China Unit 603, D Block, CAMIC International Convention Center, No 3, Hua Jia Di East road, ChaoYang district, Beijing 100102 P.R. China
Contact: Tel.: +86 (10) 8476 0106 Fax: +86 (10) 8476 0090	Email: china@safegate.com Internet: www.adbsafegate.com
ADB SAFEGATE, Germany	ADB SAFEGATE Germany GmbH Konrad-Zuse-Ring 6, D-68163 Mannheim Germany
Contact: Tel.: +49 (621) 87 55 76-0 Fax: +49 (621) 87 55 76-55	Email: marketing@adbsafegate.com Internet: www.adbsafegate.com



Powering Your Airport Performance from Approach to Departure

adbsafegate.com

Copyright © ADB SAFEGATE, all rights reserved

