



L-804 Elevated Runway Guard Light

User Manual

96A0218, Rev. AB, 2020/06/17

**ADB
SAFEGATE**

A.0 Disclaimer / Standard Warranty

CE certification

The equipment listed as CE certified means that the product complies with the essential requirements concerning safety and hygiene. The European directives that have been taken into consideration in the design are available on written request to ADB SAFEGATE.

ETL certification

The equipment listed as ETL certified means that the product complies with the essential requirements concerning safety and FAA Airfield regulations. The FAA directives that have been taken into consideration in the design are available on written request to ADB SAFEGATE.

All Products Guarantee

ADB SAFEGATE will correct by repair or replacement per the applicable guarantee above, at its option, equipment or parts which fail because of mechanical, electrical or physical defects, provided that the goods have been properly handled and stored prior to installation, properly installed and properly operated after installation, and provided further that Buyer gives ADB SAFEGATE written notice of such defects after delivery of the goods to Buyer. Refer to the Safety section for more information on Material Handling Precautions and Storage precautions that must be followed.

ADB SAFEGATE reserves the right to examine goods upon which a claim is made. Said goods must be presented in the same condition as when the defect therein was discovered. ADB SAFEGATE further reserves the right to require the return of such goods to establish any claim.

ADB SAFEGATE's obligation under this guarantee is limited to making repair or replacement within a reasonable time after receipt of such written notice and does not include any other costs such as the cost of removal of defective part, installation of repaired product, labor or consequential damages of any kind, the exclusive remedy being to require such new parts to be furnished.

ADB SAFEGATE's liability under no circumstances will exceed the contract price of goods claimed to be defective. Any returns under this guarantee are to be on a transportation charges prepaid basis. For products not manufactured by, but sold by ADB SAFEGATE, warranty is limited to that extended by the original manufacturer. This is ADB SAFEGATE's sole guarantee and warranty with respect to the goods; there are no express warranties or warranties of fitness for any particular purpose or any implied warranties of fitness for any particular purpose or any implied warranties other than those made expressly herein. All such warranties being expressly disclaimed.

Standard Products Guarantee

Products of ADB SAFEGATE manufacture are guaranteed against mechanical, electrical, and physical defects (excluding lamps) which may occur during proper and normal use for a period of two years from the date of ex-works delivery, and are guaranteed to be merchantable and fit for the ordinary purposes for which such products are made.



Note

See your sales order contract for a complete warranty description.

FAA Certified product installed in the United States and purchased or funded with monies through the Airport Improvement Program (AIP) installations guarantee

ADB SAFEGATE L858 Airfield Guidance Signs are warranted against mechanical and physical defects in design or manufacture for a period of 2 years from date of installation, per FAA AC 150/5345-44 (applicable edition).

ADB SAFEGATE L858(L) Airfield Guidance Signs are warranted against electrical defects in design or manufacture of the LED or LED specific circuitry for a period of 4 years from date of installation, per FAA EB67 (applicable edition).

ADB SAFEGATE LED light fixtures (with the exception of obstruction lighting) are warranted against electrical defects in design or manufacture of the LED or LED specific circuitry for a period of 4 years from date of installation, per FAA EB67 (applicable edition).



Note

See your sales order contract for a complete warranty description.

Liability



WARNING

Use of the equipment in ways other than described in the catalog leaflet and the manual may result in personal injury, death, or property and equipment damage. Use this equipment only as described in the manual.

ADB SAFEGATE cannot be held responsible for injuries or damages resulting from non-standard, unintended uses of its equipment. The equipment is designed and intended only for the purpose described in the manual. Uses not described in the manual are considered unintended uses and may result in serious personal injury, death or property damage.

Unintended uses, includes the following actions:

- Making changes to equipment that have not been recommended or described in this manual or using parts that are not genuine ADB SAFEGATE replacement parts or accessories.
- Failing to make sure that auxiliary equipment complies with approval agency requirements, local codes, and all applicable safety standards if not in contradiction with the general rules.
- Using materials or auxiliary equipment that are inappropriate or incompatible with your ADB SAFEGATE equipment.
- Allowing unskilled personnel to perform any task on or with the equipment.

© ADB SAFEGATE BV

This manual or parts thereof may not be reproduced, stored in a retrieval system, or transmitted, in any form or by any means, electronic, mechanical, photocopying, recording, nor otherwise, without ADB SAFEGATE BV's prior written consent.

This manual could contain technical inaccuracies or typographical errors. ADB SAFEGATE BV reserves the right to revise this manual from time to time in the contents thereof without obligation of ADB SAFEGATE BV to notify any person of such revision or change. Details and values given in this manual are average values and have been compiled with care. They are not binding, however, and ADB SAFEGATE BV disclaims any liability for damages or detriments suffered as a result of reliance on the information given herein or the use of products, processes or equipment to which this manual refers. No warranty is made that the use of the information or of the products, processes or equipment to which this manual refers will not infringe any third party's patents or rights. The information given does not release the buyer from making their own experiments and tests.

TABLE OF CONTENTS

1.0 Safety	1
1.1 Safety Messages	1
1.1.1 Introduction to Safety	2
1.1.2 Intended Use	2
1.1.3 Material Handling Precautions: Storage	3
1.1.4 Material Handling Precautions: Fasteners	3
1.1.5 Maintenance Safety	4
1.1.6 Material Handling Precautions, ESD	4
1.1.7 Arc Flash and Electric Shock Hazard	5
2.0 L-804 / ERGL	7
2.1 About this manual	7
2.1.1 Introduction	7
2.1.2 How to work with the manual	7
3.0 Product Introduction	9
3.1 Incandescent Elevated Runway Guard Light	9
3.2 Required Equipment	10
4.0 Installation	13
4.1 Introduction	13
4.2 Inspection on Arrival	13
4.3 Installation Procedures	13
4.4 Installing the L-867B Base	14
4.5 Installing on a L-867B Base	14
4.5.1 Horizontal Aiming	14
4.5.2 Adjusting Horizontal Setting	15
4.5.3 Vertical Aiming	16
4.6 Installing Coupling (Unmonitored)	18
4.6.1 Current Driven Unmonitored RGL	19
4.6.2 Voltage Driven Unmonitored RGL	19
4.7 Installing Coupling (Monitored)	19
4.7.1 Current Driven Monitored RGL	19
4.7.2 Voltage Driven Monitored RGL	19
4.8 Installing Coupling (Direct Lamp Access)	20
4.9 Adjusting Photocell	20
5.0 Maintenance	21
5.1 Maintenance Schedule	21
5.2 Replacing Lamp	21
5.3 Replacing Lens	23
5.4 Adjusting Vertical and Horizontal Settings	23
5.5 Troubleshooting	23
5.6 Operation	24
5.7 Wiring Diagrams	25
6.0 Parts	31
6.1 Spare Parts List	31
6.2 RGL Major Components	32
A.0 SUPPORT	37
A.1 ADB SAFEGATE Website	37
A.2 Recycling	38
A.2.1 Local Authority Recycling	38
A.2.2 ADB SAFEGATE Recycling	38

1.0 Safety

Introduction to Safety

This section contains general safety instructions for installing and using ADB SAFEGATE equipment. Some safety instructions may not apply to the equipment in this manual. Task- and equipment-specific warnings are included in other sections of this manual where appropriate.

1.1 Safety Messages

HAZARD Icons used in the manual

For all HAZARD symbols in use, see the Safety section. All symbols must comply with ISO and ANSI standards.

Carefully read and observe all safety instructions in this manual, which alert you to safety hazards and conditions that may result in personal injury, death or property and equipment damage and are accompanied by the symbol shown below.



WARNING

Failure to observe a warning may result in personal injury, death or equipment damage.



DANGER - Risk of electrical shock or ARC FLASH

Disconnect equipment from line voltage. Failure to observe this warning may result in personal injury, death, or equipment damage. ARC Flash may cause blindness, severe burns or death.



WARNING - Wear personal protective equipment

Failure to observe may result in serious injury.



WARNING - Do not touch

Failure to observe this warning may result in personal injury, death, or equipment damage.



CAUTION

Failure to observe a caution may result in equipment damage.

Qualified Personnel



Important Information

The term **qualified personnel** is defined here as individuals who thoroughly understand the equipment and its safe operation, maintenance and repair. Qualified personnel are physically capable of performing the required tasks, familiar with all relevant safety rules and regulations and have been trained to safely install, operate, maintain and repair the equipment. It is the responsibility of the company operating this equipment to ensure that its personnel meet these requirements.

Always use required personal protective equipment (PPE) and follow safe electrical work practice.

1.1.1 Introduction to Safety



CAUTION

Unsafe Equipment Use

This equipment may contain electrostatic devices, hazardous voltages and sharp edges on components

- Read installation instructions in their entirety before starting installation.
- Become familiar with the general safety instructions in this section of the manual before installing, operating, maintaining or repairing this equipment.
- Read and carefully follow the instructions throughout this manual for performing specific tasks and working with specific equipment.
- Make this manual available to personnel installing, operating, maintaining or repairing this equipment.
- Follow all applicable safety procedures required by your company, industry standards and government or other regulatory agencies.
- Install all electrical connections to local code.
- Use only electrical wire of sufficient gauge and insulation to handle the rated current demand. All wiring must meet local codes.
- Route electrical wiring along a protected path. Make sure they will not be damaged by moving equipment.
- Protect components from damage, wear, and harsh environment conditions.
- Allow ample room for maintenance, panel accessibility, and cover removal.
- Protect equipment with safety devices as specified by applicable safety regulations
- If safety devices must be removed for installation, install them immediately after the work is completed and check them for proper functioning prior to returning power to the circuit.

Failure to follow this instruction can result in serious injury or equipment damage

Additional Reference Materials



Important Information

- IEC - International Standards and Conformity Assessment for all electrical, electronic and related technologies.
- IEC 60364 - Electrical Installations in Buildings.
- FAA Advisory: AC 150/5340-26 (current edition), Maintenance of Airport Visual Aid Facilities.
- Maintenance personnel must refer to the maintenance procedure described in the ICAO Airport Services Manual, Part 9.
- ANSI/NFPA 79, Electrical Standards for Metalworking Machine Tools.
- National and local electrical codes and standards.

1.1.2 Intended Use



CAUTION

Use this equipment as intended by the manufacturer

This equipment is designed to perform a specific function, do not use this equipment for other purposes

- Using this equipment in ways other than described in this manual may result in personal injury, death or property and equipment damage. Use this equipment only as described in this manual.

Failure to follow this instruction can result in serious injury or equipment damage

1.1.3 Material Handling Precautions: Storage



CAUTION

Improper Storage

Store this equipment properly

- If equipment is to be stored prior to installation, it must be protected from the weather and kept free of condensation and dust.

Failure to follow this instruction can result in equipment damage

1.1.4 Material Handling Precautions: Fasteners



DANGER

Foreign Object Damage - FOD

This equipment may contain fasteners that may come loose - torque properly.

- Only use fasteners of the same type as the one originally supplied with the equipment.
- Use of incorrect combination of gaskets, bolts and nuts can create severe damages to the product installation and create safety risk .
- You need to know what base the light fixture will be installed in, in order to chose the correct gasket, bolts and nuts.
- Bolt type, length, and torque value are determined by type of base, height of spacers used, and clamp force required in FAA Engineering Brief No 83 (latest revision).
- Due to the risk of bolts vibrating loose, do not use any type of washer with the fixing bolts (such as split lock washers) other than an anti-vibration washer. Anti-vibration washers as defined in FAA EB 83 (latest edition) must be used. For installations other than FAA, use the base can manufacturer's recommendations.
- Always tighten the fasteners to the recommended torque. Use a calibrated torque wrench and apply the recommended adhesive type.
- Obey the instructions of the adhesives necessary for the fasteners.

Failure to follow these warnings may cause the fasteners to loosen, damage the equipment, potentially to loosen the equipment. This can lead to a highly dangerous situation of FOD, with potential lethal consequences.



Note

To minimize the risk of errors, the ADB SAFEGATE Sales Representative will have information on which gasket goes with which base. This information is also provided in the product Data sheets, the User Manuals and the Spare Part Lists.



CAUTION

Use of incorrect combination of gaskets, bolts and nuts can create severe damages to the product installation and create multiple safety risks.

To obtain a safe and watertight installation the O-ring and retaining bolt stated in the document must be used.

You need to know what base the light fixture will be installed in, in order to choose the correct gasket, bolts and nuts.

Failure to follow these cautions can result in equipment damage or aircraft FOD.

1.1.5 Maintenance Safety



DANGER

Electric Shock Hazard

This equipment may contain electrostatic devices

- Do not operate a system that contains malfunctioning components. If a component malfunctions, turn the system OFF immediately.
- Disconnect and lock out electrical power.
- Allow only qualified personnel to make repairs. Repair or replace the malfunctioning component according to instructions provided in its manual.

Failure to follow these instructions can result in death or equipment damage

1.1.6 Material Handling Precautions, ESD



CAUTION

Electrostatic Sensitive Devices

This equipment may contain electrostatic devices

- Protect from electrostatic discharge.
- Electronic modules and components should be touched only when this is unavoidable e.g. soldering, replacement.
- Before touching any component of the cabinet you shall bring your body to the same potential as the cabinet by touching a conductive earthed part of the cabinet.
- Electronic modules or components must not be brought in contact with highly insulating materials such as plastic sheets, synthetic fiber clothing. They must be laid down on conductive surfaces.
- The tip of the soldering iron must be grounded.
- Electronic modules and components must be stored and transported in conductive packing.

Failure to follow this instruction can result in equipment damage

1.1.7 Arc Flash and Electric Shock Hazard



DANGER

Series Circuits have Hazardous Voltages

This equipment produces high voltages to maintain the specified current - Do NOT Disconnect while energized.

- Allow only qualified personnel to perform maintenance, troubleshooting, and repair tasks.
- Only persons who are properly trained and familiar with ADB SAFEGATE equipment are permitted to service this equipment.
- An open airfield current circuit is capable of generating >5000 Vac and may appear OFF to a meter.
- Never unplug a device from a constant current circuit while it is operating; Arc flash may result.
- Disconnect and lock out electrical power.
- Always use safety devices when working on this equipment.
- Follow the recommended maintenance procedures in the product manuals.
- Do not service or adjust any equipment unless another person trained in first aid and CPR is present.
- Connect all disconnected equipment ground cables and wires after servicing equipment. Ground all conductive equipment.
- Use only approved ADB SAFEGATE replacement parts. Using unapproved parts or making unapproved modifications to equipment may void agency approvals and create safety hazards.
- Check the interlock systems periodically to ensure their effectiveness.
- Do not attempt to service electrical equipment if standing water is present. Use caution when servicing electrical equipment in a high-humidity environment.
- Use tools with insulated handles when working with airfield electrical equipment.

Failure to follow these instructions can result in death or equipment damage

2.0 L-804 / ERGL

The ERGL incandescent Runway Guard Light is an elevated unidirectional flashing yellow light fixture that provides a distinctive warning to pilots that they are approaching a runway holding position and are about to enter an active runway. The ERGL is typically installed in pairs, one on either side of the taxiway holding position. It can also be used in combination with IRGL (In-pavement Runway Guard Light), ISTB (In-pavement Stop Bar Light), and ESTB (Elevated Stop Bar Light) to provide additional safety under low-visibility conditions on the airfield.

2.1 About this manual

2.1.1 Introduction

This technical manual presents installation and maintenance information required for the incandescent ERGL elevated runway guard light.

The manual shows the information necessary to:

- Install and maintain the ERGL.

2.1.2 How to work with the manual

1. Become familiar with the structure and content.
2. Carry out the actions completely and in the given sequence.

3.0 Product Introduction

The L-804 Runway Guard Light is an elevated unidirectional flashing yellow light fixture that provides a distinctive warning to pilots that they are approaching a runway holding position and are about to enter an active runway. The RGL is also used in combination with L-852G (In-pavement Runway Guard Light), L-852S (In-pavement Stop Bar Light), and L-862S (Elevated Stop Bar Light) to provide additional safety under low-visibility conditions on the airfield.



3.1 Incandescent Elevated Runway Guard Light

Compliance with Standards

FAA:	L-804 AC 150/5345-46 (Current Edition). ETL Certified. Meets the requirements of Low-Visibility Taxiway Lighting Systems as specified by FAA AC 150/5340-30.
ICAO:	Annex 14, Vol. I, Para 5.3.22 and Appendix 2 Fig. A2-25
CE:	Complies with the requirements of the EMC Directive 2004/108/EC

Uses

FAA L-804 and ICAO

- Runway guard light
- Runway incursion prevention

The L-804 Runway Guard Light is an elevated unidirectional flashing yellow light fixture that provides a distinctive warning to pilots that they are approaching a runway holding position and are about to enter an active runway. The RGL is also used in combination with L-852G (In-pavement Runway Guard Light), L-852S (In-pavement Stop Bar Light), and L-862S (Elevated Stop Bar Light) to provide additional safety under low-visibility conditions on the airfield.

Features

- Input: 2.8 A to 6.6 A, 50/60 Hz Current-Driven/FAA Mode 1; 120 VAC or 220-240 VAC, 50/60 Hz Voltage-Driven/FAA Mode 2.
 - Mode 1: Current-Driven-powered by series lighting circuit; lamp intensity varies with current supplied to the fixture by the series circuit
 - Mode 2: Voltage-Driven-powered from either 120 VAC or 220-240 VAC parallel lighting circuit and equipped with photocell to control lamp intensity. Photocell energizes lamps at full intensity during high light levels and then reduces intensity to 30% during low ambient light conditions.
- Lamps: Two, type PK30d, 150 W/6.6 A Quartz
- Lamp Life: Rated at 1,000 hours at 6.6 A
- Flash Rate: Alternating flashes, 45-50 per minute
- Adjustable Light Beam: 0° to 20° vertically; ±20° horizontally
- Includes lamps, frangible column, and tether

- The RGL can be aimed both vertically and horizontally and is typically installed in pairs, one on either side of the taxiway holding position
- The two RGL light sources are surrounded by a black face plate and independent visors to reduce the amount of incident sunlight, thereby maximizing the contrast during the lamp ON/ OFF cycle
- Lamp replacement is achieved without tools to minimize downtime
- Access to the electronic control device is achieved through a hinged waterproof lid that permits easy replacement of the controller if needed
- Fixture is fabricated from corrosion-resistant materials, and all exterior surfaces are painted aviation yellow for added protection and visibility
- High-strength 1832RGL base plate is mandatory for FAA applications and should be used for ICAO applications. See data sheet 2012 for details.
- Remote monitoring option using a multiple-pin plug is available for the Mode 1, Current-Driven system
- Direct Lamp Access Option-No internal control PCB is present in RGL assembly. Fixture is controlled (flash rate) and monitored from an intelligent lighting control system module, such as ADB's BRITE™ System.

Operating Conditions

Temperature:	-40°F to +131 °F (-40 °C to +55 °C)
Humidity:	0 to 100%
Wind:	Withstands wind velocities up to 300 mph (480 kph)

Electrical Supply

Mode 1 - 165 VA load (requires a 150 W or 200 W isolation transformer)

RGL Kits

ON/OFF Switch Kit	94A0281
Provides ON/OFF switch on input of Runway Guard Light (current-driven only)	

Packaging

In cardboard box:	30 × 22 × 17 in (37.5 × 27.5 × 21.25 cm)
Net weight:	37 lb (16.8 kg)

3.2 Required Equipment

Refer to [Table 1](#) for required equipment that is supplied. Refer to [Table 2](#) for required equipment that is not supplied. Refer to the *Parts* section for part numbers.

Table 1: Required Equipment Supplied

Description	Quantity
L-804 runway guard light. Includes lamps, frangible column, and 2-pin L-823 cordset, or a 4-pin cordset, or a 5-pin cordset with matching harness.	1
Instruction manual	1 per order

Table 2: Required Equipment Not Supplied

Description	Quantity
Level	1
L-867B light base plate (Part Number 1832RGL). This base plate must be ordered as a separate item. Refer to the Warning below for using the L-867B light base.	1
Wire, AWG 16 (minimum), 600 V–AWG 12 (maximum) 600 V	As required
Ground wire, AWG 6, solid copper	As required
Ground rods	As required
Torque wrench	As required



WARNING

FOD

- Use only the L-867B heavy duty light base supplied by ADB Safegate.
- See FAA specification AC 150/5345-46 wind loading requirements.

Failure to observe this warning will result in damage to the installed L- 804 RGL caused by high wind loads

4.0 Installation

Figure 1: L-804 Runway Guard Light

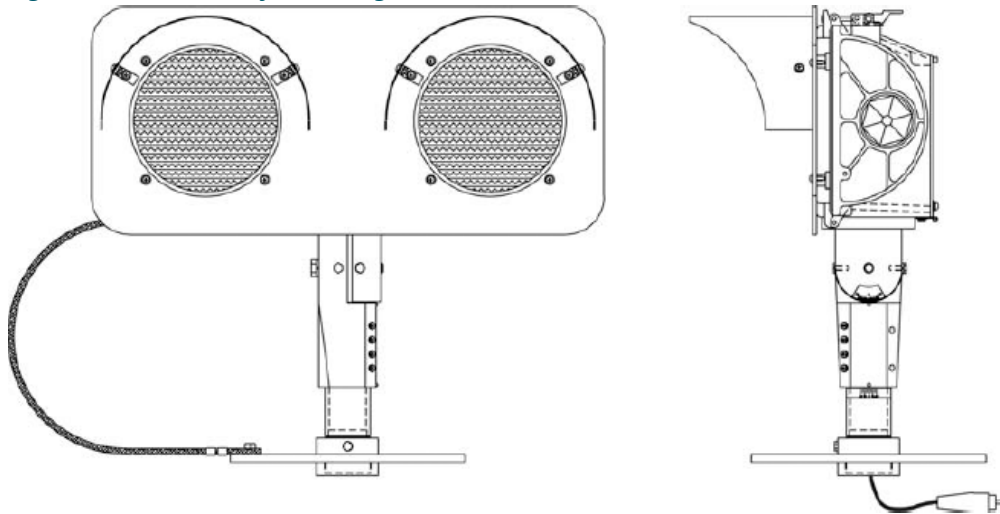

4.1 Introduction

The L-804 runway guard light is an elevated light fixture consisting of two lamps mounted side by side in the same housing that alternately flash 45-50 times per minute in yellow or red light to identify taxiway holding position lines.

The light fixture is unidirectional and can be aimed in elevation vertically from 0 to +20 degrees, and horizontally ± 20 degrees. The L-804 is manufactured in accordance with FAA specification AC 150/5345-46 and the International Civil Aviation Organization (ICAO) specification Annex 14.

This section provides instructions for installing the L-804 Runway Guard Light (RGL).

Refer to the airport project plans and specifications for the specific installation instructions.

4.2 Inspection on Arrival

The equipment is shipped ready for installation. Handle equipment very carefully to prevent component damage. Unpack the carton upon receipt and check the contents and their condition. Note any exterior damage to the carton that might lead to detection of equipment damage.

If you note any damage to any equipment, file a claim with the carrier immediately. The carrier may need to inspect the equipment.

4.3 Installation Procedures

L-804 RGLs are installed at a runway holding position to provide a distinctive warning to anyone that they are about to enter an active runway. Normally the L-804 RGLs are installed in pairs, one on either side of the taxiway. Refer to FAA Advisory Circular, AC 150/5340-30, Design and Installation Details for Airport Visual Aids for dimensional location of the elevated L-804 RGL.

The L-804 RGL is designed to be installed on an L-867B light base housing using an L-867B heavy duty base plate that has been specifically designed per FAA specifications found in FAA AC 150/5345-46B to withstand the high bending moments induced on the elevated fixture.



Note

L-804 RGL shall not be stake mounted per FAA AC 150/5345-46.

The ADB Airfield Solutions mounting system includes a frangible column, L-823 cordset, L-867B special base plate, and tether assembly. See [Figure 3](#).

4.4 Installing the L-867B Base

To install the base, perform the following procedure:

1. Install the L-867B per the site plans and specifications. See FAA AC 150/5340-30 for additional installation instructions.
2. Orient the cable entrance hubs of the base in the proper directions.
3. Level the light base so that the mounting flange surface is flush with the finished grade.
4. With the light base at proper orientation and held at proper elevation, pour concrete around the outside of the base. If the base is installed outside the concrete pad, backfill with compacted earth.
5. Slope top of concrete away from the flange portion of the base.
6. In closed duct systems installed in soil conditions of good drainage, use light bases having a drain hole to prevent water accumulation.
7. Pull field cable and connect the L-830, if specified, in the light base.
8. Install the base plate w/gasket on top of the light base. The baseplate is designed to receive the RGL frangible coupling using a female thread.

4.5 Installing on a L-867B Base

To install the L-804, perform the following procedure:

1. If using the current driven L-804, install the L-804 RGL assembly and frangible column, and connect the L-823 cordset supplied with the RGL to an L-830, 100 W/6.6 A isolation transformer. See [Figure 8](#) in the *Wiring Schematics* section for wiring connections for current driven monitored and unmonitored versions.
If using the voltage driven L-804, install the L-804 RGL assembly and frangible column, and connect the L-823 cordset supplied with the RGL to 120 or 220-240 Vac input. See [Figure 9](#) and [Figure 10](#) in the *Wiring Schematics* section for wiring connections for voltage driven monitored and unmonitored versions.
If using the Direct Lamp Access L-804, install the L-804 assembly and frangible column, and connect the L-823 cordsets supplied with the RGL to the two BRITE outputs. The connection order is not important. See [Figure 11](#) in the *Wiring Schematics* section for wiring connections for the Direct Lamp Access versions.
2. Bolt the base plate to the light base.



Note

Only use two of the mounting bolts at this time and only hand tighten these bolts. After horizontal aiming has been completed and verified, install the remaining baseplate bolts and then torque bolts to 180 – 190 In-Lbs.

3. Aim the L-804 RGL both vertically and horizontally per site plans and specifications. Aiming procedure is as follows:

4.5.1 Horizontal Aiming



Note

See [Figure 4](#) and [Installing Coupling \(Unmonitored\)](#) or [Installing Coupling \(Monitored\)](#) before proceeding. Back out or remove the two hex head set screws that are in the side of the baseplate hub so that the coupling can be screwed into the hub.

Before screwing the coupling into the baseplate, use a black marker to put “tick mark” in line with the slot and above the frangible groove as shown in the photo below. The tick-mark will aid in locating the slot after the coupling is screwed into the baseplate hub

Place "Tick-Mark" Here

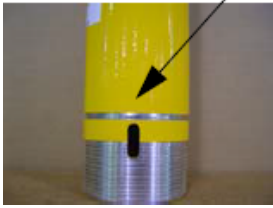

1. Apply anti-seize paste on threads and then screw the frangible coupling into the hub on the baseplate until the frangible groove is just above the top edge of the hub.

Locate the set screw hole in the side of the hub that is nearest to the slot in the coupling by locating the "Tic-mark." Rotate the coupling, either clock or counter-clockwise, until the "tick-mark" on the coupling is in line with the set screw hole in the hub.

i Note

It is important to make sure that the slot and the set screw hole are aligned because of the close fit between the slot and the ¼-20 screw. The close fit between the screw and the slot prevents the coupling from turning and loosening when the face of the RGL is subjected to jet engine exhaust or wind.

2. Thread the set screw into the hub and through the slot in the coupling. The screw must pass through the slot so it does not tightened against the screw threads on the coupling. Hand-tighten this screw only until final horizontal aiming has been completed.

4.5.2 Adjusting Horizontal Setting

To adjust the horizontal setting, perform the following procedure:

1. Thread the set screw into the hub and through the slot in the coupling. The screw must pass through the slot so it does not tightened against the screw threads on the coupling. Hand-tighten this screw only until final horizontal aiming has been completed.
2. See [Figure 2](#) and photo below. Locate the four Phillips head screws – ref Item 8 in Fig 3 and loosed them so that the frangible coupling can be inserted into the hub. Also, if necessary, loosen the two 3/8-16 allen hex head set screws in the RGL adjustable joint – Ref Item 7 in Fig 3.

Zero ("0") Screw Hole



Zero ("0") Hole



i Note

The Zero ("0") on the horizontal label that is affixed to the frangible coupling, has been aligned at the factory with the index pin pressed into the lower hub of the adjustable arm. This alignment will then allow the 10-32 screw to be screwed into the top center Zero ("0") hole and pass through the Zero ("0") hole that is located at the top of the coupling. See figures above.

3. Rotate RGL assembly until the indicator pin that is found at the bottom edge of the adjustable arm hub is aligned with the desired angle. The horizontal angle label that is affixed to the coupling is marked in 5 degree increments. See the following figure.

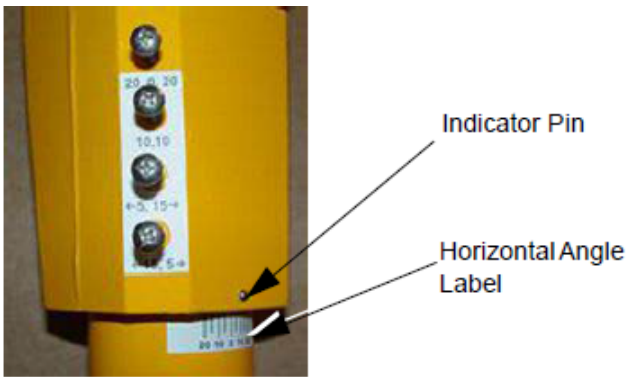

Note

The appropriate screw to tighten all the way into the mating hole in the frangible coupling is determined by the degrees adjusted. For example, if the horizontal is adjusted to 20 degrees, the top screw marked 20, 0, 20 should go in all the way. Hand tighten all four screws. See photos above.

Verify that the selected angle meets the requirements of the site plans and specifications.

If the horizontal aiming angle is not correct make one or both of the following adjustments:

4. Remove the two screws in the side of the baseplate hub and rotate the coupling slot to line up with the other tapped hole in the hub. Repeat horizontal aiming procedure above.
5. If additional adjustment is needed then remove the two mounting bolts used to fasten the baseplate to the L868B light base. Rotate the baseplate either clock or counter-clock wise at least 30 degrees. Repeat the horizontal aiming procedure above.
6. Once horizontal aiming is completed install and torque all mounting hardware that secures the baseplate to the L867B light base.

4.5.3 Vertical Aiming

To adjust the vertical setting, perform the following procedure:

1. See [Figure 2](#) . Loosen two Allen hex set screws on side shown in photo and on opposite side.

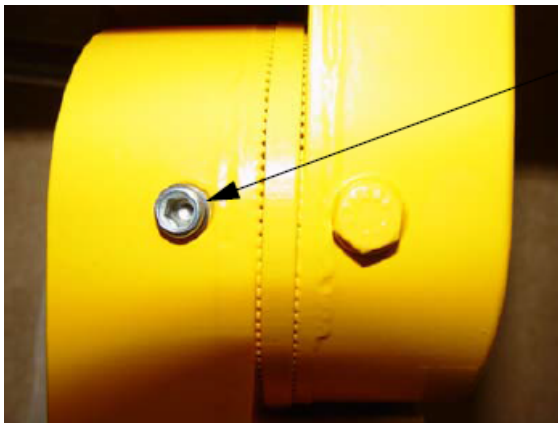

Set Screw - 2 Places
180 Degrees Apart

2. Loosen hex bolt (6) on the face (side) of RGL.
3. Adjust the vertical setting to the desired number of degrees in one-degree increments by lining up the indicator pin (9) from 0 to +20 degrees.
4. Tighten the hex bolt (6). Refer to [Table 8](#) .
5. Tighten the hex bolts (1). Refer to [Table 8](#) .



Note

See Figure 2 for additional installation instructions and bolt torque values. Refer to Table 8 .

- After the RGL has been aimed and operation has been verified, install the tether by attaching one end of the tether to one of the bolts on the center housing of the RGL and attach the other end to nearest bolts securing the baseplate to the light base housing. 5..



Note

There are two set screws in the side of the hub. These set screws are used when the RGL is being aimed horizontally.

Figure 2: Bolt Torque Values

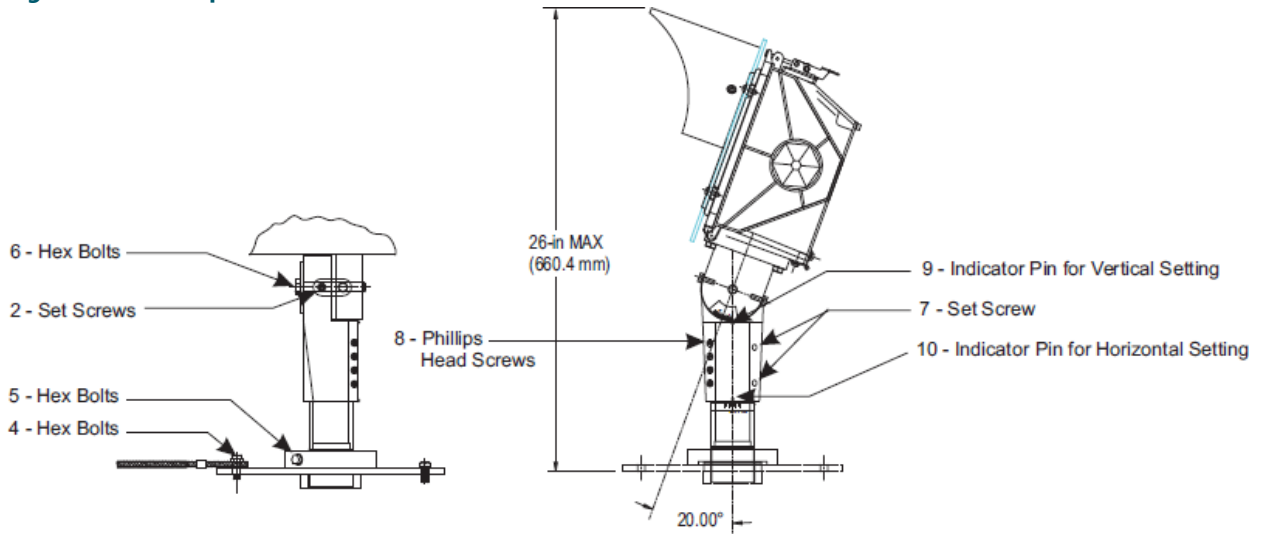

Table 3: Table 8. Bolt/Screw Torque Values

Item Number	Number/Type	Torque Values
2	2 set screws	140 in-lb
4	6 hex bolt	15 ft-lb
5	2 hex bolts	70 ft-lb

Table 3: Table 8. Bolt/Screw Torque Values (continued)

Item Number	Number/Type	Torque Values
6	1 hex bolt	77 ft-lb
7	2 set screws	40 ft-lb
8	4 Phillips head screws	Hand-tighten

Figure 3: L-804 Base Installation

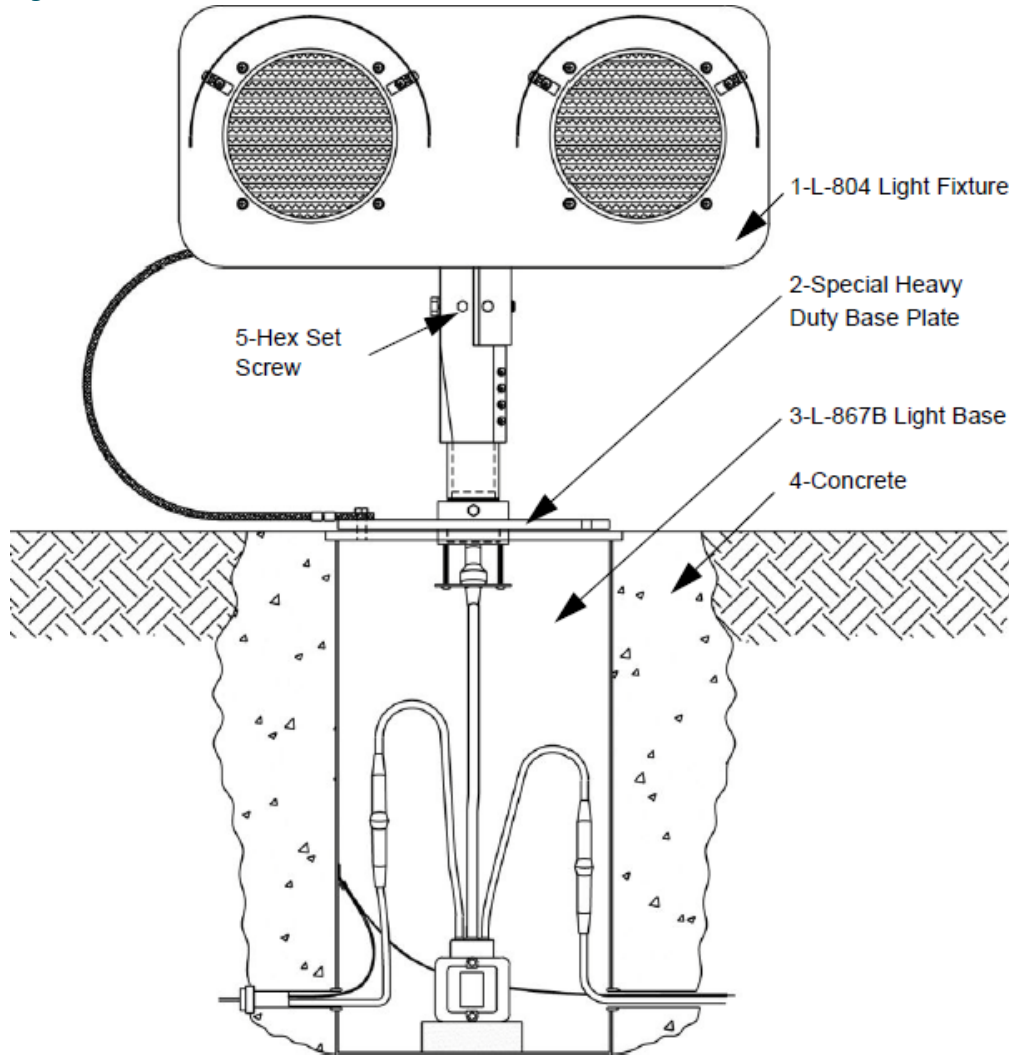

- 1. L-804 Light Fixture
- 2. Special Heavy Duty Base Plate
- 3. L-867B Light Base
- 4. Concrete
- 5. Hex Set Screw

4.6 Installing Coupling (Unmonitored)

This subsection describes how to install the coupling for the current and voltage driven unmonitored versions of the RGL.

4.6.1 Current Driven Unmonitored RGL

See [Figure 8](#) in the Wiring Schematics section for the current driven unmonitored wiring schematic. See [Figure 4](#) . To install the coupling for the current driven unmonitored version, plug the L-830 transformer secondary cordset (2) into the 2-pin L-823 connector (1).

Figure 4: L-804 Coupling (Monitored and Unmonitored Versions)

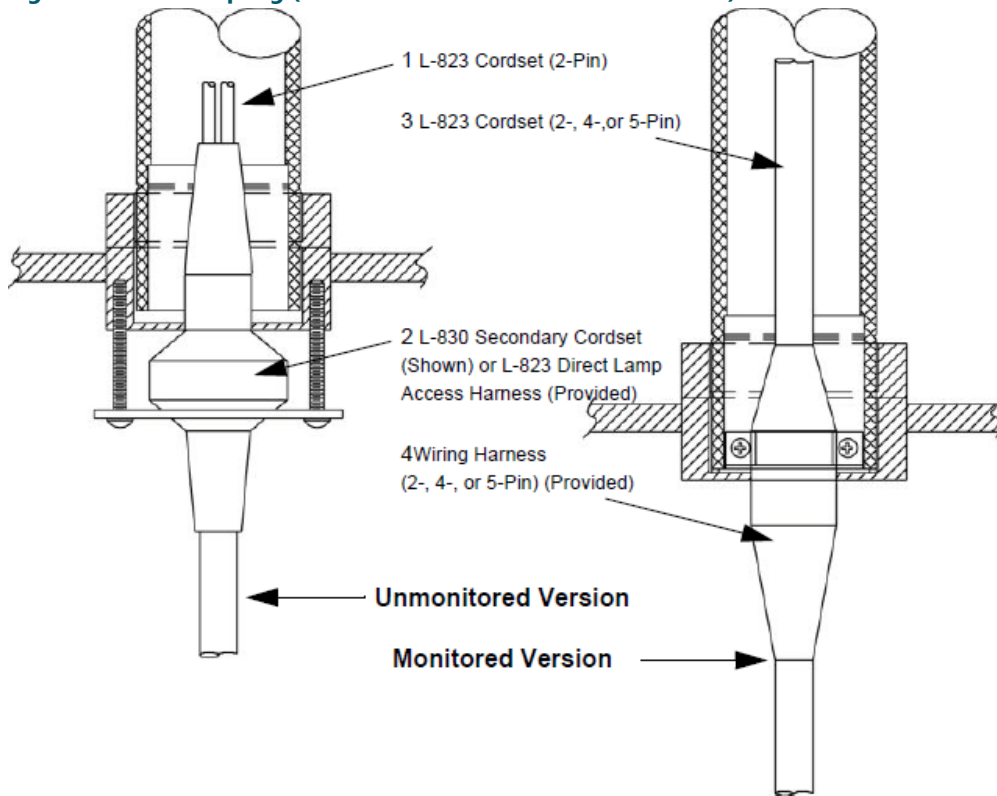

4.6.2 Voltage Driven Unmonitored RGL

See [Figure 9](#) in the Wiring Schematics section for the 120 V and the 220-240 V voltage driven unmonitored wiring schematics.

To install the coupling for the voltage driven unmonitored version, perform the following procedure:

1. See [Figure 4](#) . Plug the 2-pin L-823 cable (1) into the L-823 receptacle (2).
2. Wire the free ends to the proper voltage source.

4.7 Installing Coupling (Monitored)

This subsection describes how to install the coupling for the current and voltage driven monitored versions of the RGL.

4.7.1 Current Driven Monitored RGL

See [Figure 8](#) in the Wiring Schematics section for the current driven monitored wiring schematic.

To install the coupling for the current driven monitored version RGL, perform the following procedure:

1. See [Figure 4](#) . Plug the 5-pin cordset cable (3) into the 5-pin harness (4).
2. Wire the monitor leads (orange, red, and green) to the monitor circuit.

4.7.2 Voltage Driven Monitored RGL

See [Figure 10](#) in the Wiring Schematics section for the 120 V and the 220-240 V voltage driven monitored wiring schematics.

To install the coupling for the voltage driven monitored version RGL, perform the following procedure:

1. See [Figure 4](#) . Plug the 5-pin cordset cable (3) into the 5-pin harness (4).
2. Connect the black and white wires to the proper voltage source.
3. Wire the monitor leads (orange, red, and green) to the monitor circuit.

4.8 Installing Coupling (Direct Lamp Access)

See [Figure 11](#) in the Wiring Schematics section for the Direct Lamp Access wiring schematic.

To install the coupling for the Direct Lamp Access version of the RGL, perform the following procedure:

1. See [Figure 4](#) . Plug the 4-pin cordset cable (3) into the 4-pin harness (4).
2. Plug the two 2-pin cordset cables into the BRITE controller or equivalent. The order is not important.

4.9 Adjusting Photocell

To adjust the photocell, perform the following procedure:

1. See [Figure 5](#) . Open the electronics enclosure (3) and loosen the lock nut (4) holding the photocell (1).
2. Adjust the photocell to the proper direction.



Note

For units with a photocell, the photocell window (2) should be adjusted to point more or less north.

3. Tighten the lock nut.
4. Close and secure the electronics enclosure.

Figure 5: Adjusting Photocell

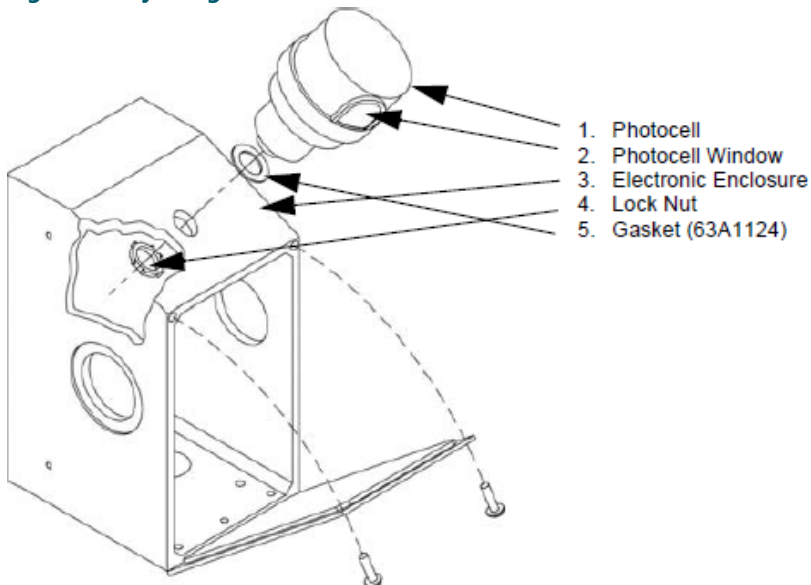

5.0 Maintenance

This section provides maintenance information and procedures for the L-804 runway guard light.

5.1 Maintenance Schedule

To keep the L-804 light operating efficiently, follow a preventive maintenance schedule. Refer to [Table 4](#) . Refer to FAA AC 150/5340-26 for more detailed information.

Table 4: L-804 Runway Guard Light Maintenance

Interval	Maintenance Task	Action
Daily	Check for burned-out lamp.	Replace lamp. Refer to <i>Replacing Lamp</i> in this section.
	Check for dim lamp.	Clean lens. Replace lamp, if necessary. Refer to <i>Replacing Lamp</i> in this section.
Weekly	Check for vegetation.	Remove vegetation. Use weed killer.
	Check for dirty lens.	Clean lens.
	Check for incorrect aiming angle.	Adjust elevation setting.
Semi-annually	Check for moisture in the fixture.	Check for cracks in the lens or housing. Repair or replace lens or housing.
Annually	Inspect fixture for deterioration.	Repair or replace fixture.
	Inspect cable insulation.	

5.2 Replacing Lamp



WARNING

- Turn off the disconnect switch or main circuit breaker before attempting to service the fixture.
- Touching the quartz lamps with bare fingers may seriously shorten lamp life. If you touch the quartz lamp, clean the lamp with tissue moistened with isopropyl alcohol.
- Failure to observe a warning may result in personal injury, death or equipment damage.



Note

Refer to the Parts section for part numbers.

To replace the lamp, perform the following procedure:

1. See [Figure 6](#) . Remove the front cover (6) by releasing the two latches (5) on the top of the L-804 RGL.

Figure 6: Replacing Lamp/Lens

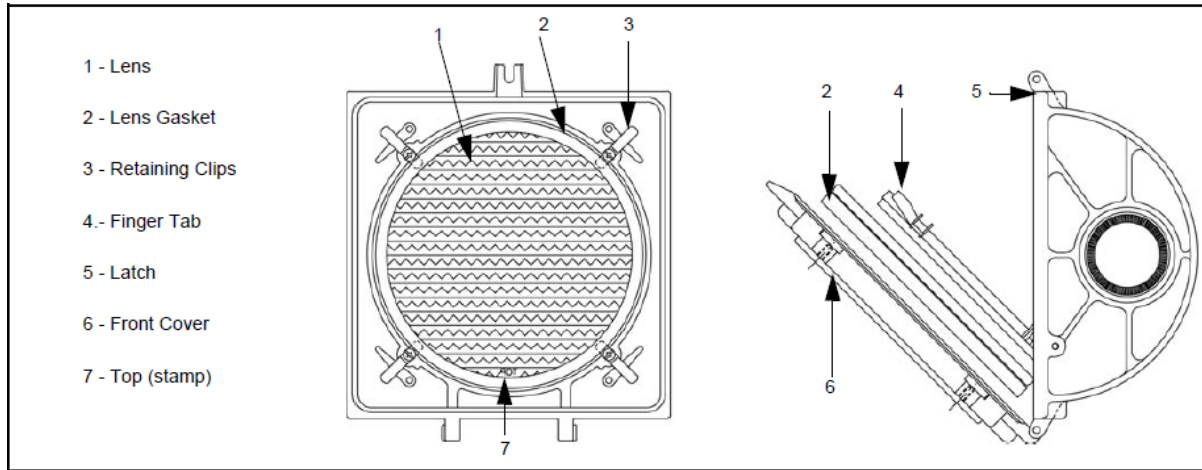

Note

The cover is hinged at the bottom and will swing down and out.

2. Locate the finger tab (4). Pull the tab toward you. The reflector assembly will swing down and out.
3. See [Figure 7](#) . Disconnect the lamp leads (4).
4. Release the bulb retainer spring (7) and remove the lamp (2).
5. Remove the protective sleeving from the new lamp (do not touch the lamp bulb).

Figure 7: Positioning Reflector

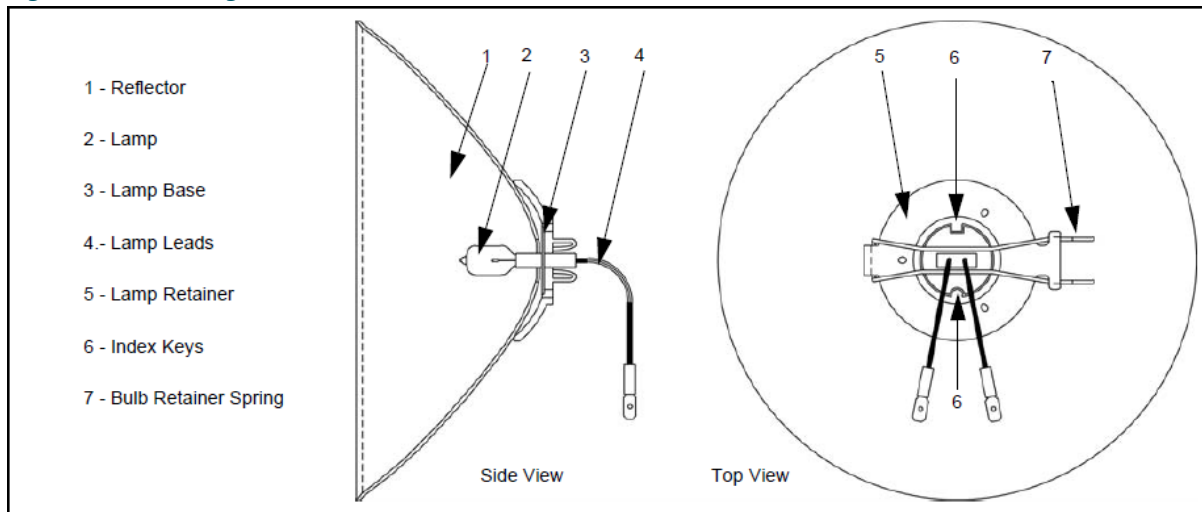

6. Insert the reflector (1) with bulb retainer spring (7) positioned horizontally and index keys (6) vertically on the lamp retainer (5).
7. Insert a new quartz lamp (FAA:6.6 A/100 W/PK30d and ICAO:6.6 A/150 W/PK30d) (2) into the socket so that the lamp base (3) fits into the index keys.
8. Reverse procedure to install the lamp and close up the assembly.

5.3 Replacing Lens

To replace the lens, perform the following procedure:

1. See [Figure 6](#) . Open both latches (5) on the top of the unit.
2. Tilt the face plate open.
3. Loosen the four retaining clips (3) on the inside of the lens door.
4. Turn the retaining clips so you can pull out the lens (1) and the lens gasket (2).
5. Take note of how the lens gasket is positioned and remove the lens and gasket.
6. Remove the old lens and place the new lens in the gasket. Position the gasket and lens with the word TOP on the bottom of the light fixture (7) when the lens door is closed.

5.4 Adjusting Vertical and Horizontal Settings

See installation procedure sections on vertical and horizontal aiming on pages 12 thru 14.

5.5 Troubleshooting



WARNING

Electrical Shock

- Allow only qualified personnel to perform the following tasks. Observe and follow the safety instructions in this document and all other related documentation.
- De-energize the circuit and lock out the circuit or regulator so that the circuit cannot be energized by remote means before attempting to service the fixture.

Failure to follow the warning may result in personnel injury or death.

This section contains troubleshooting information. This information covers only the most common problems that you may encounter. If you cannot solve the problem with the information given here, contact your local ADB Airfield Solutions representative for help.



Note

In case of failure of external controller, refer to the maintenance document for the controller.

Table 5: Troubleshooting Steps

Problem	Possible Cause	Corrective Action
1. Lamp not energizing	Defective lamp	Replace lamp. Refer to <i>Replacing Lamp</i> in the <i>Maintenance</i> section.
	Defective PCB	Replace PCB.
	Deteriorated wire insulation	Replace wires.
	Moisture inside assembly causing current leakage	Open up light fixture. Inspect yellow lens for cracks. Replace lamp and any damaged parts. Refer to <i>Replacing Lamp</i> in the <i>Maintenance</i> section.
2. Short lamp life	Defective lamp	Replace lamp. Refer to <i>Replacing Lamp</i> in the <i>Maintenance</i> section.
	Current too high	Check lamp current.

Table 5: Troubleshooting Steps (continued)

Problem	Possible Cause	Corrective Action
3. Lamps dim	Dirty lens	Clean with soft cotton cloth and glass cleaner or mild detergent.
	Current too low	Check lamp current.
4. Both lamps on and not flashing	PCB DC power supply failure	Replace PCB.
5. Current driven RGL won't flash lamps at low current settings	Defective green transformer in wiring harness	Replace the transformer or tighten the connections for it.

5.6 Operation

The Runway Guard Light (RGL) is available in two different models: constant current driven unit and the constant voltage driven unit.

The brightness control of the current driven RGL is via the series current loop while the brightness of the voltage driven RGL is controlled by a photocell input.

The basic operation of the RGL in both cases is the same. Once powered up, the RGL alternately flashes one lamp and then the other at the default brightness setting. The basic control board has several status LEDs. Refer to [Table 6](#).

Table 6: L-804 LED Functions

LEDs	Voltage Driven Function	Current Driven Function
Lamp A	Lights when lamp B is off	Lights when lamp A is off
Lamp B	Lights when lamp A is off	Lights when lamp B is off
Monitor	Lights when one lamp or the other has failed to flash, or is burned out	Lights when one lamp or the other has failed to flash, or is burned out

See [Figure 8](#) through [Figure 10](#) in the Wiring Schematics section for monitored wiring connections. Two optional dry switch contacts are available: normally closed and normally open. These two contacts indicate a failure has occurred. If the unit is powered up and operating correctly, the normally open contact will be opened and the normally closed contact will be closed. If any failure is detected, the contacts will change state. If a lamp is burned out, the unit will default to flashing the good lamp, but will close the fault contacts. A current driven RGL will short the burned out lamp to prevent discontinuities in the current waveform.

When a lamp is burned out, the unit will check every second to see if a bulb has been replaced. When a good or replaced bulb is detected, the unit will automatically start flashing both lamps again and reset the failure output contacts. There is no need to do a power down reset to initiate correct operation. Changing lamps with the power on is safe to do only on a voltage fed unit. Never change lamps on a current driven circuit without turning the associated regulator off first.



WARNING

Electric Shock

Do not change lamps on a current driven unit with the CCR power on.
Failure to follow this warning may result in personnel injury or death.

5.7 Wiring Diagrams

This section provides wiring schematics for the Incandescent L-804 Runway Guard Light (RGL). See [Figure 8](#) through [Figure 11](#) . Refer to [Table 7](#) to locate a particular wiring schematic. For more information about part numbers, refer to the *Parts* section.

Table 7: Locating Wiring Schematics for RGL Versions

L-804 RGL Version	Figure Number
Current driven monitored	Figure 8
Current driven unmonitored	Figure 8
120 V voltage driven monitored	Figure 10
220-240 V voltage driven monitored	Figure 10
120 V voltage driven unmonitored	Figure 9
220-240 V voltage driven unmonitored	Figure 9
Direct Lamp Access (manufactured prior to November 1, 2000)	Figure 11
Direct Lamp Access (manufactured after November 1, 2000)	Figure 11

Figure 10: L-804 RGL Voltage Driven - Monitored - 43A2389 (2 of 2)

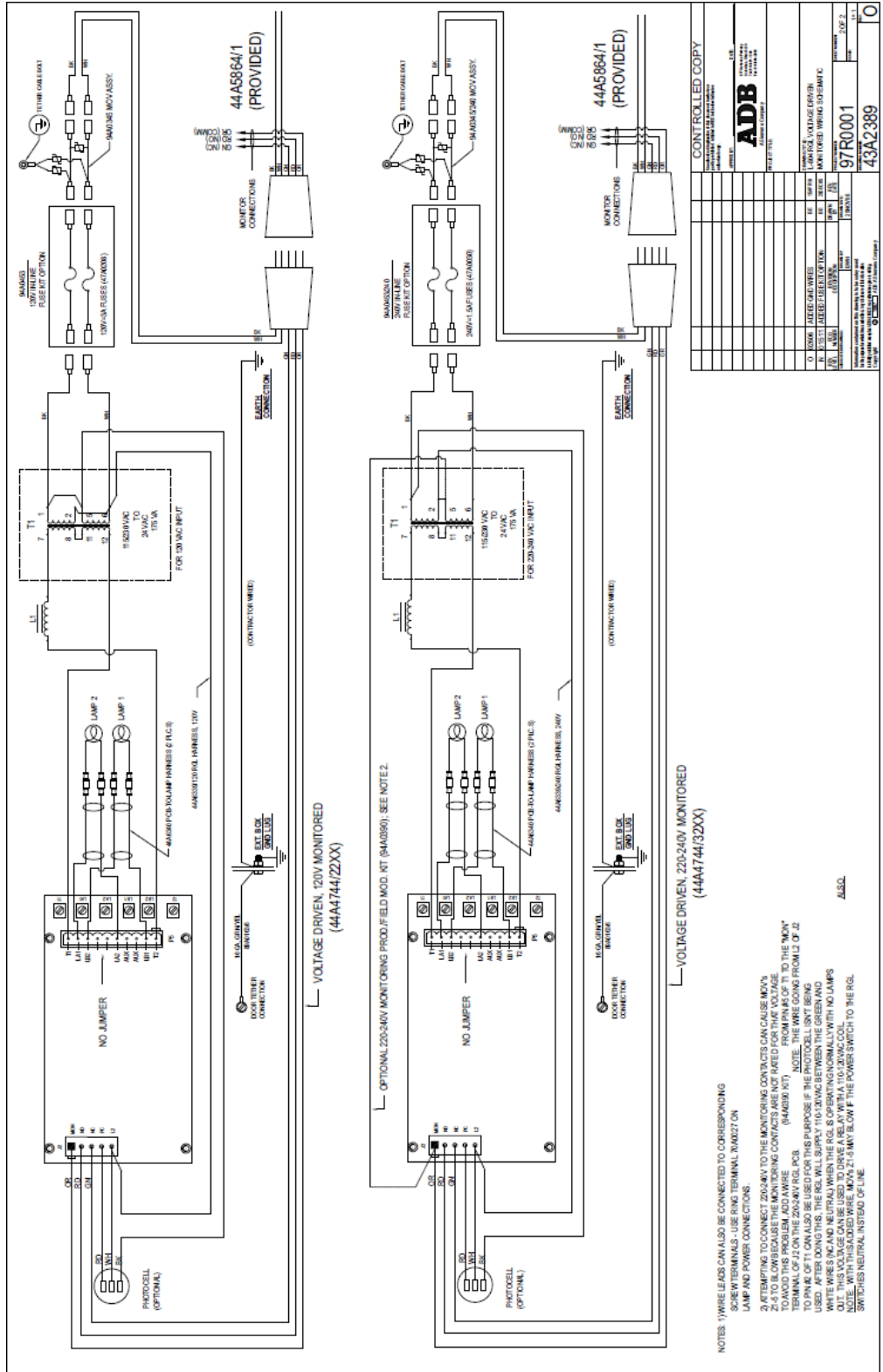
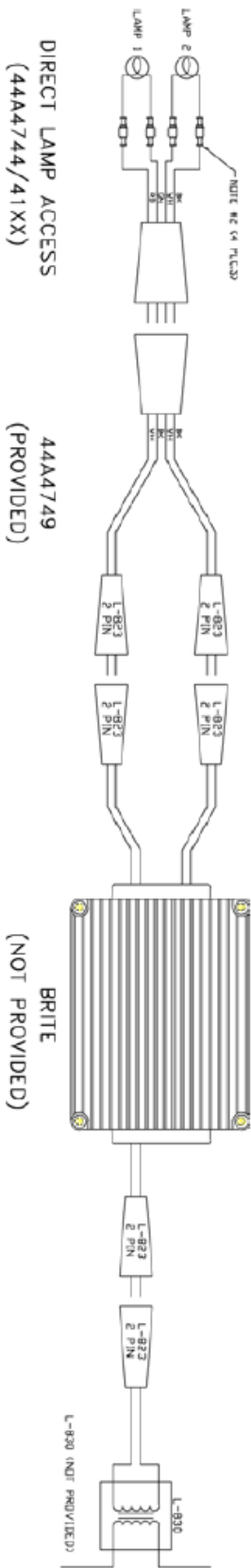
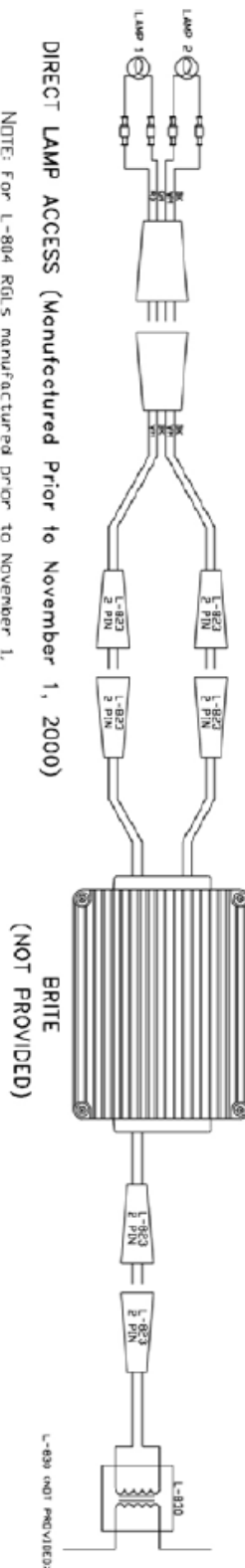

Figure 11: Direct Lamp Access



NOTES: 1) WIRE LEADS CAN ALSO BE CONNECTED TO CORRESPONDING SCREW TERMINALS - USE RING TERM. 70A0027 ON LAMP AND POWER CONNECTIONS.
 2) USE FEW DISC. #70A0329 REF.

Direct Lamp Access (Manufactured after November 1, 2000)
 NOTE: For L-804 RGLs manufactured after November 1, 2000, see Figure 18 wiring schematic. Parts are not interchangeable with mating parts manufactured before November 1, 2000.

MODEL	FUNCTION
44-11A-1	INDICATES 50 F.A.S.-E-S PER MINUTE
44-11A-2	INDICATES 40 F.A.S.-E-S PER MINUTE
44-11A-3	INDICATES 30 F.A.S.-E-S PER MINUTE
44-11A-4	INDICATES 20 F.A.S.-E-S PER MINUTE
44-11A-5	INDICATES 10 F.A.S.-E-S PER MINUTE

Direct Lamp Access Wiring Schematic (Manufactured after November 1, 2000)

6.0 Parts

Ordering Code^{1,4}

44A4744 - X X X X

Power

- 1 = Mode 1, Current-Driven (ETL Certified)⁶
- 2 = Mode 2, Voltage-Driven, 120 VAC (ETL Certified)
- 3 = Mode 2, Voltage-Driven, 220-240 VAC (ETL Certified)
- 4 = Direct Lamp Access, Current-Driven

Remote Monitor Feature

- 1 = Non-monitored (ETL Certified)
- 2 = Monitored (ETL Certified)⁵

Lens

- 1 = Traffic Signal Yellow (ETL Certified)
- 2 = Traffic Signal Red³
- 3 = ICAO Yellow²
- 4 = Red/Green³

Photocell Feature

- 1 = Without photocell, Mode 1 only (ETL Certified)
- 2 = With photocell, Mode 2 only (ETL Certified)

Notes

- ¹ Runway Guard Lights should only be powered with ferroresonant type CCRs and not with thyristor type CCRs
- ² Complies with color and illumination of ICAO Annex 14, Vol. 1, 6th edition specifications for Runway Guard Lights.
- ³ Color not recognized by the FAA
- ⁴ 1832RGL base plate is ordered and shipped separately. See data sheet 2012 for more details.
- ⁵ Not available in direct lamp access version. Monitoring, if needed, is provided by externally connected equipment.
- ⁶ The L-804 halogen, current powered, 50 Hz, non-monitored, ICAO yellow fixture (Part No. 44A4744-1131) carries the CE Mark.

6.1 Spare Parts List

Table 8: RGL Spare Parts

Description	Part No.
Base plate, L-867B heavy-duty	1832RGL
Canopy, FAA	60A2408
Canopy, ICAO	60A2408-1S
Canopy brackets	60A2410
Frangible column, 2 - 11.5 TPI (Used with 1832RGL)	60A2398
Frangible coupling, 11 TPI threaded (Normally used in metric applications. Not for use with 1832RGL base plate)	60A2398-1
Gasket, lens	63A1109
Lamp, 100 W/6.6 A, Pk30d (FAA)	44B1643
Lamp, 150 W/6.6 A, Pk30d (ICAO)	48A0353
Lens, ICAO yellow	63A0930-2
Lens, traffic signal red	63A0930-1
Lens, traffic signal yellow	63A0930
PCB, current-driven	44A6122-C
PCB, voltage-driven	44A6122-V

Table 8: RGL Spare Parts (continued)

Description	Part No.
Photocell (120 V)	48A0089
Photocell socket	49A0095
Retrofit kit (to replace 44A4771 PCB with 44A6122-C)	94A0333

6.2 RGL Major Components

See [Figure 12](#) .



Note

Only supplied parts are included in this parts list. To locate part numbers for parts required but not supplied, for example, the L-867B base plate, refer to [Table 3](#) .



Note

Substitution of electrical components may be done only if substitution is the exact physical equivalent in body or case size and equal or better electrical characteristics with respect to tolerance, failure rate, and/or reliability.

Item	Description	Part Number	Quantity	Note
1	Photo Cell (120 V)	48A0089	1	
1	Photo Cell (240 V)	48A0089-240	1	
2	Socket	49A0095	2	
3	Gasket	63A1124	1	
4	Reflector assembly	44A4791	2	
	Lens			
	Lens, traffic signal yellow	63A0930	2	A
5	Lens, traffic signal red	63A0930-1	1 or 2	B, C
	Lens, ICAO yellow	63A0930-2	2	D
	Lens, traffic signal green	63A0930-3	1 or 2	B, C
5a	Lens Gasket	63A1109	2	
6	Canopy, FAA	60A2408	1	
	Canopy, ICAO	60A2408-1S		
7	Frangible column	60A2398	1	
8	Slip fitter	44A4783	1	
	PCB			E
9	PCB (current driven)	44A6122-C	1	F
	PCB (voltage driven)	44A6122-V	1	
10	Transformer, custom	35A0555	1	G
11	Lamp, 100 W/6.6 A (FAA)	44B1643	2	
	Lamp, 150 W/6.6 A (ICAO)	48A0353	1	

Item	Description	Part Number	Quantity	Note
	Cordset			
	Cordset, current/voltage driven without monitor	73A0009-31	1	
NS	Cordset, current/voltage driven with monitor	73A0124-8	1	
	Cordset, Direct Lamp Access (4-pin)	70A0557	1	A,B
	Cordset, Direct Lamp Access (L-823 4-pin male)	70A0558	1	C
NS	L-867B light base plate	1832RGL	1	

NOTE A: ETL certified only.

NOTE B: Not ETL certified.

NOTE C: Quantity of 2 for lens option red-red, quantity of 2 for lens option green-green, or quantity of 1 red and 1 green for lens option red-green).

NOTE D: ETL tested/ICAO compliant only.

NOTE E: For current driven RGLs with PCB board 44A4771, request Current Driven RGL PCB Retrofit Kit 94A0333 to replace old PCB 44A4771.

NOTE F: For voltage driven RGLs, request PCB 44A6122-V to replace old PCB 44A4805.

NOTE G: For current driven RGLs only.

NOTE A: Wiring harness and cordset to be used on RGLs manufactured prior to November 1, 2000.

NOTE B: Parts 44A4749 and 70A0427 are not interchangeable with individual parts 70A0557 and 70A0558.

NOTE C: Wiring harness and cordset to be used on RGLs manufactured after November 1, 2000.

NS: Not Shown. The L-867B heavy duty light base plate must be ordered separately.

Figure 12: L-804 Runway Guard Light

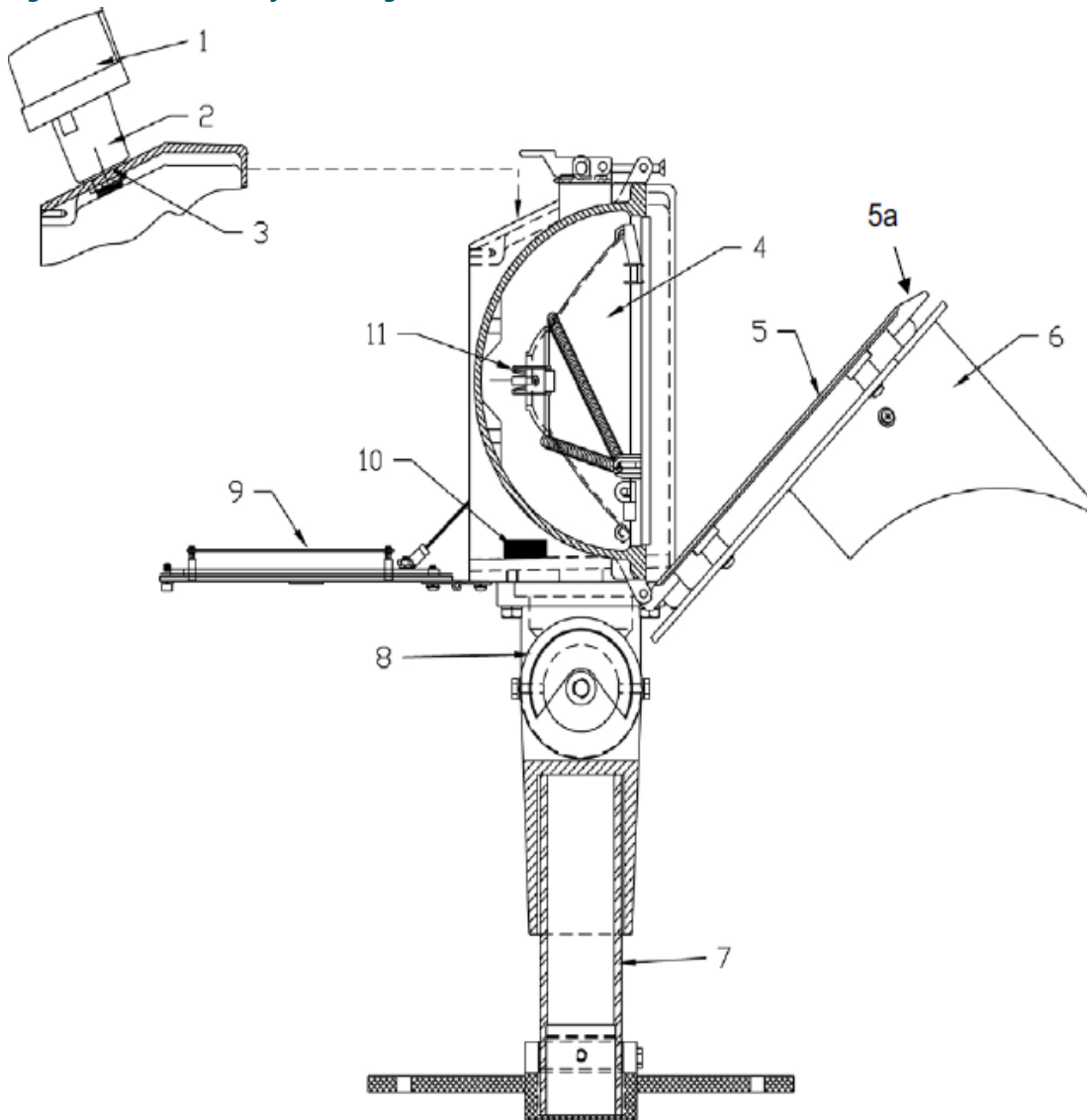

Item	Description	Part Number	Quantity	Note
1	Photo Cell	48A0089	1	
2	Socket	49A0095	2	
3	Gasket	63A1124	1	
4	Reflector assembly	44A4791	2	
	Lens			
	Lens, traffic signal yellow	63A0930	2	A
5	Lens, traffic signal red	63A0930-1	1 or 2	B, C
	Lens, ICAO yellow	63A0930-2	2	D
	Lens, traffic signal green	63A0930-3	1 or 2	B, C
6	Canopy	60A2408 (FAA)	1	
	Canopy	60A2408-1 (ICAO)	1	
7	Frangible column	60A2398	1	

Item	Description	Part Number	Quantity	Note
8	Slip fitter	44A4783	1	
	PCB			E
9	PCB (current driven)	44A6122-C	1	F
	PCB (voltage driven)	44A6122-V	1	
10	Transformer, custom	35A0555	1	G
11	Lamp, 100 W/6.6 A	44B1643	2	
	Cordset			
	Cordset, current/voltage driven without monitor	73A0009-31	1	
NS	Cordset, current/voltage driven with monitor	73A0124-8	1	
	Cordset, Direct Lamp Access	70A0557	1	A,B
	Cordset, Direct Lamp Access	70A0558	1	C
NS	L-867B light base plate	1832RGL	1	

NOTE A: ETL certified only. NOTE B: Not ETL certified.

NOTE C: Quantity of 2 for lens option red-red, quantity of 2 for lens option green-green, or quantity of 1 red and 1 green for lens option red-green).

NOTE D: ETL tested/ICAO compliant only.

NOTE E: For current driven RGLs with PCB board 44A4771, request Current Driven RGL PCB Retrofit Kit 94A0333 to replace old PCB 44A4771.

NOTE F: For voltage driven RGLs, request PCB 44A6122-V to replace old PCB 44A4805.

NOTE G: For current driven RGLs only.

NOTE A: Wiring harness and cordset to be used on RGLs manufactured prior to November 1, 2000.

NOTE B: Parts 44A4749 and 70A0427 are not interchangeable with individual parts 70A0557 and 70A0558.

NOTE C: Wiring harness and cordset to be used on RGLs manufactured after November 1, 2000.

NS: Not Shown.

Appendix A: SUPPORT

Our experienced engineers are available for support and service at all times, 24 hour/7 days a week. They are part of a dynamic organization making sure the entire ADB SAFEGATE is committed to minimal disturbance for airport operations.

ADB SAFEGATE Support

Live Technical Support - Americas

If at any time you have a question or concern about your product, just contact ADB SAFEGATE's technical service department. Trained in all areas of system issues, troubleshooting, quality control and technical assistance, our highly experienced Technical support specialists are available 24 hours a day, seven days a week to provide assistance over the phone.

ADB SAFEGATE **Americas Technical Service & Support (US & Canada): +1-800-545-4157**

ADB SAFEGATE Americas Technical Service & Support (International): +1-614-861-1304

During regular business hours, you can also Chat with a Service Technician. We look forward to working with you!

Before You Call

When you have an airfield lighting or system control system problem it is our goal to support airfield maintenance staff as quickly as possible. To support this effort we ask that you have the following information ready before calling.

- The *airport code*
- If not with an airport, then company name (prefer customer id number)
- Contact phone number and email address
- Product with part number preferable or product number
- Have you reviewed the product's manual and troubleshooting guide
- Do you have a *True RMS* meter available (and any other necessary tools)
- Be located with the product ready to troubleshoot

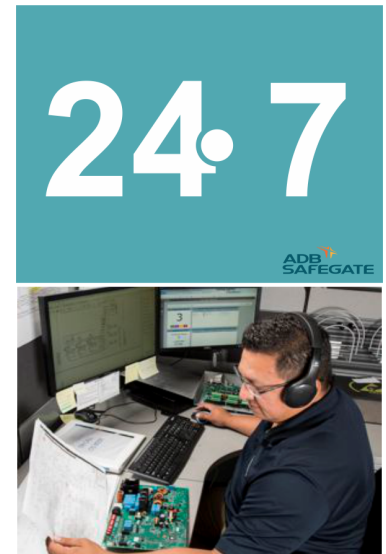

Note

For more information, see www.adbsafegate.com, or contact ADB SAFEGATE Support via email at support@adbsafegate.com or

Brussels: +32 2 722 17 11

Rest of Europe: +46 (0) 40 699 17 40

Americas: +1 614 861 1304. Press 3 for technical service or press 4 for sales support.

China: +86 (10) 8476 0106

A.1 ADB SAFEGATE Website

The ADB SAFEGATE website, www.adbsafegate.com, offers information regarding our airport solutions, products, company, news, links, downloads, references, contacts and more.

A.2 Recycling

A.2.1 Local Authority Recycling

The disposal of ADB SAFEGATE products is to be made at an applicable collection point for the recycling of electrical and electronic equipment. The correct disposal of equipment prevents any potential negative consequences for the environment and human health, which could otherwise be caused by inappropriate waste handling. The recycling of materials helps to conserve natural resources. For more detailed information about recycling of products, contact your local authority city office.

A.2.2 ADB SAFEGATE Recycling

ADB SAFEGATE is fully committed to environmentally-conscious manufacturing with strict monitoring of our own processes as well as supplier components and sub-contractor operations. ADB SAFEGATE offers a recycling program for our products to all customers worldwide, whether or not the products were sold within the EU.

ADB SAFEGATE products and/or specific electrical and electronic component parts which are fully removed/separated from any customer equipment and returned will be accepted for our recycling program.

All items returned must be clearly labeled as follows:

- For *ROHS/WEEE* Recycling
- Sender contact information (Name, Business Address, Phone number).
- Main Unit Serial Number.

ADB SAFEGATE will continue to monitor and update according for any future requirements for *EU directives* as and when *EU member states* implement new *regulations* and or *amendments*. It is our aim to maintain our *compliance plan* and assist our customers.

Company Addresses

ADB SAFEGATE	ADB SAFEGATE, Belgium: Leuvensesteenweg 585, B-1930 Zaventem Belgium
Contact: Tel.: +32 2 722 17 11, Fax: +32 2 722 17 64	Email: marketing@adbsafegate.com Internet: www.adbsafegate.com
Americas LLC	ADB SAFEGATE, Americas: 977 Gahanna Parkway, Columbus, OH 43230 USA
Contact: Tel.: +1 (614) 861 1304, Fax: +1 (614) 864 2069	Email: sales.us@adbsafegate.com Internet: www.adbsafegate.com
ADB SAFEGATE Sweden AB	ADB SAFEGATE, Sweden: Djurhagegatan 19 SE-213 76 Malmö Sweden
Contact: Tel.: +46 (0)40 699 17 00, Fax: +46 (0)40 699 17 30	Email: marketing@adbsafegate.com Internet: www.adbsafegate.com
ADB SAFEGATE Airfield Technologies Ltd. China	ADB SAFEGATE, China: Unit 603, D Block, CAMIC International Convention Center, No 3, Hua Jia Di East road, ChaoYang district, Beijing 100102 P.R. China
Contact: Tel.: +86 (10) 8476 0106, Fax: +86 (10) 8476 0090	Email: china@safegate.com Internet: www.adbsafegate.com
ADB SAFEGATE Germany GmbH	ADB SAFEGATE Germany GmbH, Mannheim: Konrad-Zuse-Ring 6, D-68163 Mannheim Germany
Contact: Tel.: +49 (621) 87 55 76-0, Fax: +49 (621) 87 55 76-55	Email: marketing@adbsafegate.com Internet: www.adbsafegate.com



Powering Your Airport Performance from Approach to Departure

adbsafegate.com

Copyright © ADB SAFEGATE, all rights reserved

