

POWER EQUIPMENT

MCR3

Microprocessor Controlled Constant Current Regulator



Compliance with Standards

FAA: AC 150/5345-10 (current edition), L-828, L-829.

ICAO: Aerodrome Design Manual Part 5, para. 3.2 (current edition)

IEC: 61822

CENELEC: EN61822

Various national standards

Uses

The MCR³ regulator is specially designed for the supply of airport lighting series circuits at various intensity levels.

Features

The MCR³ is the next generation of ADB SAFEGATE's MCR-type of which several thousand units are in use worldwide. The well-known microprocessor controlled thyristor regulator has been further modernized. Its new set-up allows on-site upgrading, from a basic constant current regulator to a full option unit including following features:

- Full digitally controlled and regulated CCR,
- An integrated menu driven human machine interface (HMI) allowing full configuration on-site without any additional equipment,
- Upgradeable remote maintenance diagnostic functionality
- Optional built-in circuit selector or master for the AGLAS individual lamp control and monitoring system (ILCMS),
- High regulation response dynamic,
- Optimal output current stabilisation for non-resistive load conditions,
- Remote control and monitoring via combined multiwire, and single or redundant field bus (J-BUS),
- Flash memory allows remote updating of the CCR with the latest software version, or reconfiguration,
- Completely stand alone as well for configuration as for operation.

Perfectly suited for new technology LED lights and conventional lamp lights, or any combination thereof.



Fig. 2: MCR³ in substation

POWER EQUIPMENT

MCR3

Concept

The MCR³'s operating principle is based on back to back coupled thyristors adjusting the supply to the output transformer. A digital regulator determines the thyristor firing angle to adjust the output current to a reference value. The reference value varies with the selected brightness step.

The regulator consists of three main components:

1. a power module
2. a digital control module
3. an output transformer

Optional dedicated PCBs for earth default and lamp default detection, and various remote control modes, as well as built-in circuit selectors or an AGLAS Master for an ILCMS turn the CCR into an integrated full option control and monitoring unit.

Control module

The control module consists of a number of individual PCBs, each laid out to cover one function as indicated in the block diagram. (Fig. 3)

The on-board microcontroller controls and monitors the operation of the regulator.

The main monitoring functions are:

- Supply voltage monitoring
- Output current monitoring for over-current
- Output monitoring for open circuit

(too low output current)

Power modules

The MCR power modules are built around thyristor packs.

Irrespective of the supply voltage, the complete power range – from 2.5 to 30 kVA – is covered by three modules, rated 50, 63 and 110 A.

Together with the control PCBs, the power module forms an easy serviceable low voltage compartment.

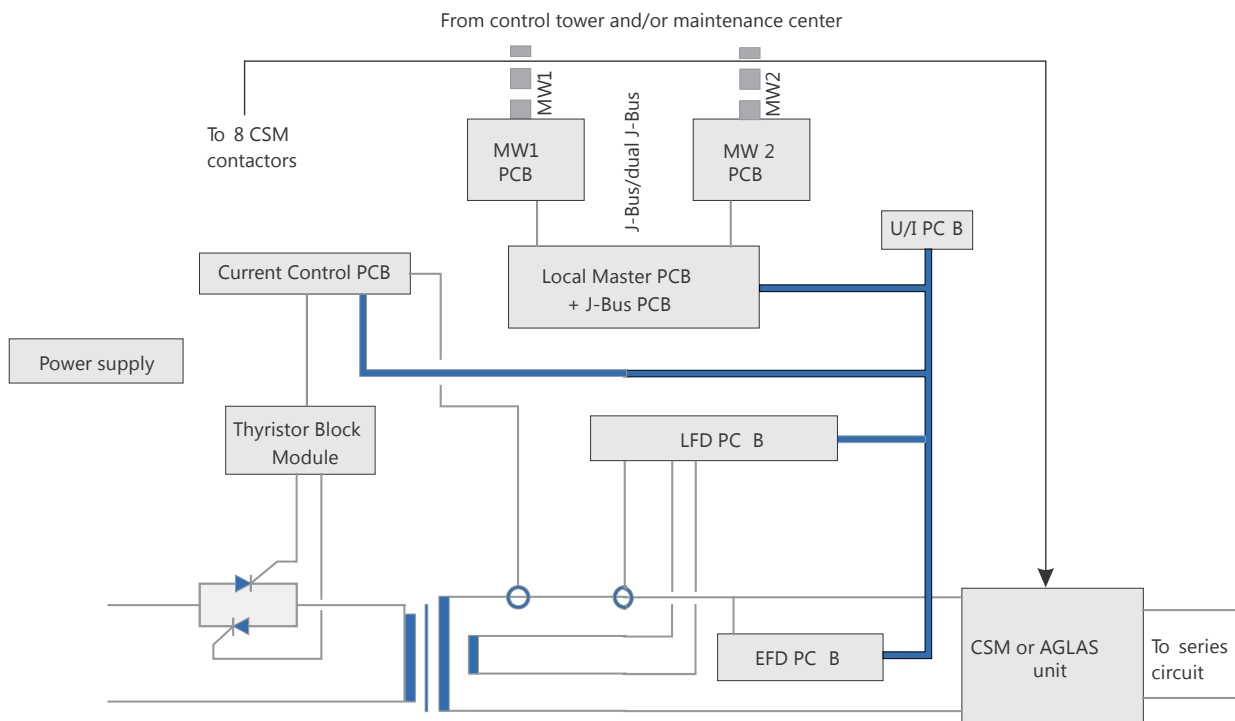

Fig. 3: MCR³ block diagram

Components back view MCR³

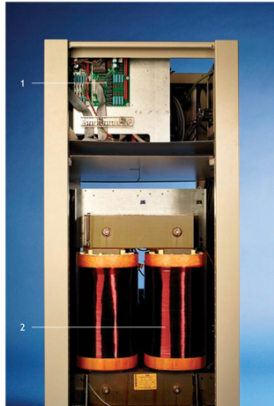

Fig. 4: Back view MCR³

- 1. Remote control PCBs
- 2. Output transformer

Construction



Fig. 6: Front view MCR³ – 15 to 30 kVA

The FAA-style stand alone execution houses a complete regulator in one enclosure, divided into two compartments:

- 1. Low voltage compartment, containing the power, the control and monitoring PCBs, and a fused input switch.
- 2. High voltage compartment, containing the output transformer, current and voltage measurement transformers, and lightning arrestors.

Optional incorporated circuit selector or AGLAS master units for an ILCMS are located below the power compartment of the CCR.

Finish

Baked epoxy powder coating.

Color: light grey RAL 7032 with RAL 7005 front panel.

Components front view MCR³

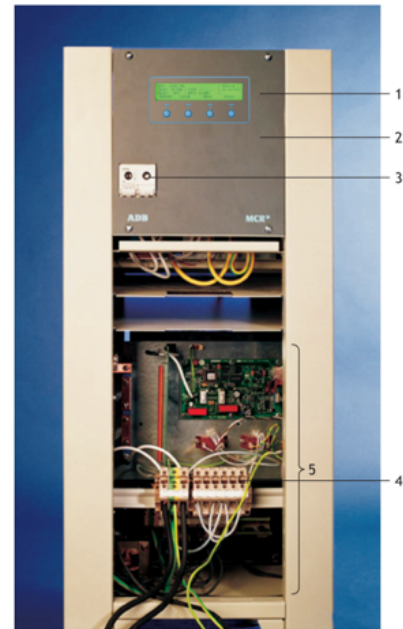

Fig. 5: Front view MCR³ – 2.5 to 10 kVA

- 1. Menu driven HMI with command buttons
- 2. Control module
- 3. Main fused switch
- 4. Tap settings for output transformer
- 5. High voltage compartment

POWER EQUIPMENT

MCR3

Standard Options

Lamp Fault Detection (LFD)

The LFD provides accurate and real time detection of the number of burnt out lamps and power loss in a series circuit.

The option consists of a PCB mounted into the low voltage compartment of the CCR, a current transformer, including voltage limitation for level adaptation, and a voltage measurement directly on the power transformer.

The number of failed lamps is reported to the alphanumeric display (Fig. 7) on the CCR front – on which also the LFD functionality can be adjusted, to the remote control system, or to a PC when connected to the CCR.

Earth Fault Detection (EFD)

The EFD PCB measures the insulation resistance of the series circuit to the ground with the regulator both ON and OFF. A stabilized DC voltage is applied between the series circuit and the ground, irrespective of the operating voltage.

The resistance is calculated from the resulting leakage current, and is reported to the alphanumeric display on the CCR front to the remote control, or the case occurring, to a laptop PC connected to the CCR. The measuring range is from 10 KΩ to 250 MΩ. The accuracy of this measurement is better than 2 % from 100 kΩ to 40 MΩ.

Rolling castors

The MCR³ can be equipped with two fix and two pivoting rolling castors to ease displacement during service activities.

High Voltage Cut-out (SCO)

An electro mechanical interlocking safety device that isolates the series circuit from the CCR output. It also provides earthing and insulation resistance measurement functions. See catalogue leaflet A.06.455 for SCO description.

Time counter

Optional elapsed time indication can be read directly from the HMI display on the CCR front. The elapsed time meter option includes three types of indication:

- CCR on time
- CCR on 100% brightness step
- CCR on other brightness steps

Circuit selector

The IEC compliant built-in circuit selectors allow simultaneous control of up to 8 partial circuits or individual control of 2 circuits, thus providing substantial savings in space and installation costs. (Fig. 8)



Fig. 8: 7.5 kVA with built-in Circuit Selector

If used in combination with LFD, the lamp default detection is available for either:

- Individual sub circuits
- The total circuit connected to the CCR

Dual LFD functionality in case of circuit selector for alternate switching of 2 individual circuits.

Calibration needs to be performed accordingly for each (sub) circuit considered.

LDF indications for combined sub circuits will be erroneous

Circuit selectors are also available as separate wall mounted cabinets.



Fig. 7: Display MCR³

AGLAS master

The built-in AGLAS Master allows for additional savings in space and both, cabling and installation cost, while the common use of H.V. components provides additional savings.

Over-voltage protection

Protects the input against over-voltage spikes by means of optional 40kA 8/20 μS surge arrestors.

Primary power factor and efficiency

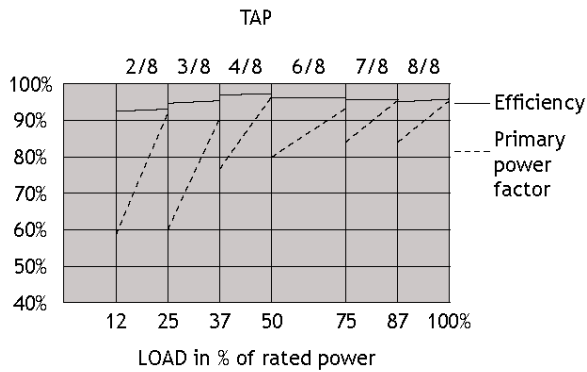

Fig. 9: Typical curves for a regulator rated 30 kVA

Selector switch position	CCR Type					
	3-step	4-step	5-step	6-step	7-step	8-step
1	4.8 (15)	3.3 (10)	2.8 (8.5)	2.7 (8.2)	2.2 (6.7)	2.2 (6.7)
2	5.5 (17)	4.4 (13)	3.4 (10)	3.4 (10)	2.8 (8.5)	2.8 (8.5)
3	6.6 (20)	5.5 (17)	4.1 (12)	3.9 (12)	3.4 (10)	3.4 (10)
4	-	6.6 (20)	5.2 (16)	4.5 (14)	4.1 (12)	3.9 (12)
5	-	-	6.6 (20)	5.4 (16)	5.2 (16)	4.6 (14)
6	-	-	-	6.6 (20)	6.4 (19)	5.5 (17)
7	-	-	-	-	6.6 (20)	6.4 (19)
8	-	-	-	-	-	6.6 (20)

Notes
() values for 20 A CCR
Minimum output currents: 1.8A (6.6A) or 5.5A (20A)

Fig. 10 Standard Output Current Presets (A)

Technical Data

Performance figures are always equal to, or better than specified hereunder.

Input voltage ratings

FAA types: 220, 230, 240, 380, 400 or 415 V, 50/60 Hz, single phase, 2-wires

IEC types: 230 or 400 V

Remote control voltage

Multiwire: 24 or 48 to 60 V DC

Multiplex: J-Bus protocol over RS485 and RS422

Any combination of multiwire and BUS (or redundant bus)

Brightness control (Fig. 10)

Up to 8 brightness steps, user adjustable in 255 levels Output current regulation Within ± 1% of 6.6 A (or 20 A), under either IEC or FAA standard conditions. NB: At lower brightness settings, tolerances on output current exceed 1%

Regulation response time

Less than 0.5 seconds at full (100%) resistive load (power factor = 1)

Open circuit output voltage

Less than 1.4 times the nominal output voltage (RMS)

Efficiency (Fig. 9)

90 to 92% depending on the size, under nominal resistive load, nominal output current and nominal input voltage

Primary power factor (Fig. 9)

- 0,9 for ratings up to 10 kVA
- 0,95 for ratings 15 kVA and up

under same conditions as "Efficiency"

Taps on secondary of output transformer to match the MCR³ to the actual load of the series circuit and to achieve best efficiency and primary power factor (Fig. 9). Also to reduce waveform distortion.

Temperature

- Operating temperature: -20°C to +55°C
- Non operating temperature: -40°C to +70°C
- Temperature rise under the most adverse conditions meets

ANSI C57.12.91

Degree of protection: IP 21

Remote Control and Monitoring:

The MCR³ offers the following choices:

1. A multi-wire remote control
With two voltage levels: either 24 or 48 V DC. The multi-wire version provides remote control and back indications of all basic functions such as remote control of brightness steps or back indication of alarms due to over-current, open circuit and the mode of operation (local or remote). The remote control and feedback signals are user programmable.
2. A multiplex remote control
The multiplex version is possible thanks to the integration of a microprocessor into the control module. It uses a single or two redundant field bus(es) with hardware according to RS485 or RS422 and J-Bus protocol. It allows the remote monitoring of a larger quantity of parameters.
3. Combined remote control
Any combination of multiwire, single or redundant bus is possible. This combination can be most helpful to separate control from monitoring functions.

MCR3



Fig. 11: Taps on secondary of output transformer

Output Parameters

Both series cable and the series transformers induce a reactive factor to the load.

Due to the reactive loads induced by both, the series cable and the series transformer, the total load connected to the CCR is never pure resistive. Therefore the only correct way to express the power rating of a CCR is in kVA. The output parameters are thus essentially:

Output current (A)	Max. RMS output voltage (V)	Rated power kVA ¹
6.6	378	2.5
6.6	606	4
6.6	757	5
6.6	1136	7.5
6.6	1515	10
6.6	2272	15
6.6	3030	20
6.6	3788	25
6.6	4545	30
20	1250	25
20	1500	30

Notes

¹ kVA = kW, if the power factor is 1

Outline Dimensions

Rating k VA	Fig.	Dimensions (mm)	Net weight (kg)
2.5	Fig. 5	600*×400×940	57
4			83
5			88
7.5			123
10			155
15	Fig. 6	600 ¹ ×600×1270	187
20			220
25			235
30			250

Notes

¹ Width dimension will be different with optional cut-out.

See leaflet A.06.455. Packing Data

Rating k VA	Net weight (kg)	Seaworthy packing	
		Case dimensions (mm)	Gross Weight (kg)
2.5	57	860 × 560 × 1300	62
4	83		133
5	88		138
7.5	123		173
10	155		205
15	187	860 × 760 × 1580	237
20	220		270
25	235		285
30	250		300

Note: In case of the following options the heights should be increased:

- 500 mm for circuit selector or AGLAS master
- 100 mm for rolling castors

Ordering Code

MCR X X X X X X X X X X

CCR Type

MCR = Micro-processor Controlled Regulator

Power Rating

- A = 2.5 kW, 6.6 A, 50/60 Hz
- B = 4 kW, 6.6 A, 50/60 Hz
- C = 5 kW, 6.6 A, 50/60 Hz
- D = 7.5 kW, 6.6 A, 50/60 Hz
- E = 10 kW, 6.6 A, 50/60 Hz
- F = 12.5 kW, 6.6 A, 50/60 Hz
- G = 15 kW, 6.6 A, 50/60 Hz
- H = 20 kW, 6.6 A, 50/60 Hz
- J = 25 kW, 6.6 A, 50/60 Hz
- K = 30 kW, 6.6 A, 50/60 Hz
- L = 25 kW, 20 A, 50/60 Hz
- M = 30 kW, 20 A, 50/60 Hz

Input Voltage (VAC)

- 1 = 230 V, IEC (not 25 or 30 kVA)
- 2 = 400 V, IEC
- 3 = 220 V, FAA, (not 25 or 30 kVA)
- 4 = 230 V, FAA, (not 25 or 30 kVA)
- 5 = 240 V, FAA, (not 25 or 30 kVA)
- 6 = 380 V, FAA
- 7 = 400 V, FAA
- 8 = 415 V, FAA

Remote Control Multi-wire

- 0 = No MW
- A = 24 VDC MW
- B = 48 VDC MW

Remote Control JBUS

- 0 = No JBUS
- A = Single JBUS
- B = Dual JBUS

LFD & EFD

- 0 = No LFD & EFD
- 1 = LFD
- 2 = EFD
- 3 = LFD & EFD
- 4 = Dual LFD (Used for CS alternate)
- 5 = Dual LFD & EFD (Used for CS alternate)

MCR³ Revision

2 = Version

Fixed Digit

1 = Fixed Digit

HMI Language

E = English

SCO & Wheels

- 0 = No SCO & No Wheels
- 1 = No SCO & with Wheels
- 2 = SCO & No Wheels
- 3 = SCO & Wheels

Hour Counters

- 0 = No Hour Counter
 - 1 = Hour Counter
 - 2 = CSR Hour Counter
- (in combination with CSR & integrated CS)

Circuit Selector

- 0 = No Integrated Circuit Selector
- A = CS, 2 Circuits, Alternate Mode
- B = CS, 2 Circuits, Simultaneous Mode
- C = CS, 3 Circuits, Simultaneous Mode
- D = CS, 4 Circuits, Simultaneous Mode
- E = CS, 5 Circuits, Simultaneous Mode
- F = CS, 6 Circuits, Simultaneous Mode
- G = CS, 7 Circuits, Simultaneous Mode
- H = CS, 8 Circuits, Simultaneous Mode

OVP Overvoltage Protection

- 0 = No OVP
- 1 = OVP for networks

Notes:

- LFD = Lamp Default Detection
- EFD = Earth Default Detection