

# Airfield Lighting Manual

IDMAN

12" Inset Lights – IDM 4572

- Inset Bidirectional Runway Centre Line Light



**Note:** *This page is blank for convenient double-sided printing.*

## 12" INSET LIGHTS

### IDM 4572

### CONTENTS

Section	Description	Page No.
<b>1.</b>	<b>INTRODUCTION .....</b>	<b>3</b>
1.1	SAFETY INSTRUCTIONS .....	3
1.1.1	<b>General safety .....</b>	<b>3</b>
1.1.2	<b>Product safety .....</b>	<b>3</b>
1.1.3	<b>Electrical maintenance .....</b>	<b>3</b>
1.1.4	<b>Mechanical maintenance .....</b>	<b>4</b>
1.2	DELIVERY AND OVERVIEW OF LIGHTS .....	4
<b>2.</b>	<b>INSTALLATION.....</b>	<b>5</b>
2.1	BEFORE YOU START.....	5
2.1.1	<b>Tools and materials required.....</b>	<b>5</b>
2.1.2	<b>Base option .....</b>	<b>5</b>
2.2	INSTALL A LIGHT IN A BASE .....	6
<b>3.</b>	<b>MAINTENANCE .....</b>	<b>7</b>
3.1	BEFORE YOU START.....	7
3.1.1	<b>Light pressure .....</b>	<b>7</b>
3.1.2	<b>Handle with care and clean.....</b>	<b>7</b>
3.2	REPLACE A LIGHT IN A BASE.....	8
3.3	WORKSHOP MAINTENANCE .....	9
3.3.1	<b>Pressure release .....</b>	<b>9</b>
3.3.2	<b>Disassemble a light cover.....</b>	<b>9</b>
3.3.3	<b>Assemble a light cover.....</b>	<b>10</b>
3.3.4	<b>Seal integrity test .....</b>	<b>10</b>
3.3.5	<b>Replace a lamp in a light.....</b>	<b>11</b>
3.3.6	<b>Remove/insert prisms and a prism gasket .....</b>	<b>12</b>
3.3.7	<b>Replace an o-ring gasket .....</b>	<b>13</b>
3.4	TECHNICAL INFORMATION .....	14
3.4.1	<b>Storage.....</b>	<b>14</b>
3.4.2	<b>Daily function check for installed equipment .....</b>	<b>14</b>
3.4.3	<b>Specification.....</b>	<b>14</b>
3.4.4	<b>Application .....</b>	<b>14</b>
3.4.5	<b>Technical characteristics .....</b>	<b>15</b>
3.5	SUPPORT .....	16
3.5.1	<b>Safegate Group Website .....</b>	<b>16</b>
3.6	RE-CYCLING .....	17
3.6.1	<b>Local Authority Re-cycling .....</b>	<b>17</b>
3.6.2	<b>Safegate Group Re-cycling.....</b>	<b>17</b>
3.7	SPARE PARTS.....	17

## Documentation

This document includes Airfield Lighting information with a focus on safety, installation and maintenance procedures.

For more information, see [www.safegate.com](http://www.safegate.com).

**Note:** *It is very important to read this document before any work is started.*

## Copyright

© Copyright 2011 by Safegate Group. All rights reserved. This item and the information contained herein are the property of Safegate Group. No part of this document may be reproduced, transmitted, transcribed, stored in a retrieval system, or translated into any language or computer language in any form or by any means otherwise, without the expressed written permission of Safegate Group, Djurhagegatan 19, SE-213 76 Malmö, Sweden.

## History

Version	Date	Description
1.0	January 2011	First Release

**Note:** *This page is to be updated with every authorised change to the document.*

## Abbreviations and Terms

This document may include abbreviations and terms.

Abbreviation	Term
CAA	Civil Aviation Authority
CCR	Constant Current Regulator
CU	Concentrator Unit
FAA	Federal Aviation Administration
ICAO	International Civil Aviation Organization
IEC	International Electrotechnical Committee
LED	Light Emitting Diode
LMS	Light Monitor and Switch unit
NATO	North Atlantic Treaty Organization
STAC	Service Technique de l'Aviation Civile (France)
STANAG	Standardization Agreement (NATO)

## 1. INTRODUCTION

IDM 4572 is a 12" is a bidirectional runway centre inset light. The main parts of the luminaire are top cover, inner cover and base receptacle, all of which are made from special corrosion resistant aluminium alloy and anodised. Running costs are extremely low due to the low power rating and the fact, that most of the parts are shared with IDM 4351, IDM 4352, IDM 4361 and IDM 2051 series of luminaires.



FIGURE 1 - 12" INSET LIGHT

### 1.1 SAFETY INSTRUCTIONS

#### 1.1.1 General safety

Make sure you read this section and are familiar with safety precautions before any work is started. Keep away from live circuits. It is vital to switch off the current securely before any installation or maintenance procedures are carried out. It is also strongly recommended to disconnect the primary circuit from CCR before these activities.

#### 1.1.2 Product safety

Airfield lighting is connected to a constant current circuit with nominal current of 6.6 amperes via an isolating transformer. The primary voltages, depending on the circuitry, are usually several kilovolts and therefore lethal. Although the open circuit voltages of the isolating transformers are much lower, the peak voltage while opening the secondary circuit under current is also hazardous. So it is vitally important to follow all the safety regulations with adequate circumspection.

In the design of this equipment all the practical safety aspects have been taken into account. It is also important to strictly follow existing international or national regulations, the instructions established by civil aviation authority or airport operator and the following instructions.

#### 1.1.3 Electrical maintenance

Valid safety regulations must always be followed. Never carry out any maintenance or maintenance measures before the current is confirmed as safely disconnected. Use extreme caution when disconnecting or connecting high voltage primary connectors.



***WARNING! PRIOR TO THE COMMENCEMENT OF WORK ALL ELECTRICAL SERVICES MUST BE ISOLATED FROM THE SUPPLY AND CONNECTED TO EARTH. FULL DETAILS OF THE WORK INVOLVED MUST BE GIVEN TO THE AUTHORISED PERSON RESPONSIBLE FOR THE ELECTRICAL ENGINEERING SERVICES AT THE AIRPORT WITH REGARD TO THE DURATION OF THE WORK AND SO ON. IT IS RECOMMENDED THAT PRIOR TO STARTING ANY CUTTING WORK THE NATURE AND LOCATION OF SERVICES SUCH AS CABLE DUCTS AND SO ON SHOULD BE IDENTIFIED. ANY INSTALLATION OR MAINTENANCE WORK SHOULD ONLY BE CARRIED OUT BY TRAINED AND EXPERIENCED PERSONNEL.***

#### 1.1.4 Mechanical maintenance

When maintaining mechanical components, it is important to follow the instructions for electrical maintenance.



**WARNING!** IT IS STRONGLY RECOMMENDED TO DEPRESSURIZE THE LIGHT BEFORE OPENING FOR MAINTENANCE. IT IS IMPORTANT TO UNDERSTAND THAT OPENING A PRESSURIZED LIGHT CAUSES THE LIGHT HALVES TO SEPARATE AT HIGH SPEED, AND MAY CAUSE PERSONAL INJURY AND DAMAGE THE LIGHT.

THE LIGHTS ARE DESIGNED TO WITHSTAND INTERNAL PRESSURE OF 1.5 BAR. IT IS NOT ALLOWED TO EXCEED 1.5 BAR OF PRESSURE IN ANY CIRCUMSTANCES. FOR THIS REASON, IT IS NOT ALLOWED TO OPEN THE INNER COVER USING COMPRESSED AIR, AS THIS MAY CAUSE PERSONAL INJURY AND DAMAGE THE LIGHT.

#### 1.2 DELIVERY AND OVERVIEW OF LIGHTS

Each unit is supplied completely assembled, tested and sealed, ready for installation. The electrical connection is made via one cable assembly; the cable is equipped with an FAA L-823 Style 6 plug.

Each unit is individually packed in a durable cardboard box, labelled with its reference name and code.

The lights are designed according to airfield placement and functionality.

Overview of lights			
Light	Colours	Power	Description
IDM 4572	Clear (C)	2 x 48W	Runway centre line inset light
	Clear / Red (C/L)	2 x 48 W	Runway centre line inset light

For more information, see [www.safegate.com](http://www.safegate.com).

## 2. INSTALLATION

Inset lights are installed in base receptacles that are stationary installed on the field. There are many different installation practices which can be adopted for bases and detailed instructions how to carry out the installation can be found on base manuals. For correct light location, it is recommended to read and comply with the following:

- ICAO: Annex 14 Volume I 5th edition 2009
- All drawings and design plans, for the particular project, to guarantee correct location for each fixture.

### 2.1 BEFORE YOU START

Make sure you have read and understand Safety Instructions on page 3.

Find out the location of the light unit that needs maintenance. If the purpose is to replace an existing light unit with new one, make sure that corresponding unit is available.

#### 2.1.1 Tools and materials required

- Lifting hooks
- Torque wrench with socket 17mm

#### 2.1.2 Base option

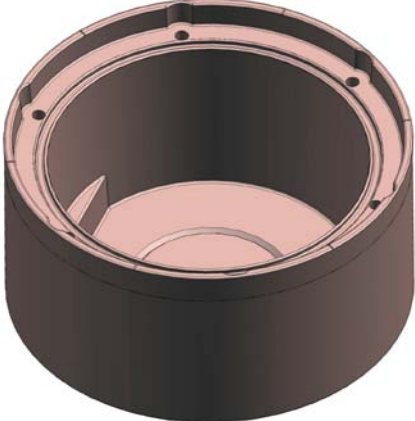
Base option for 12" fittings	Image example
The base dimensions are: outer diameter is 326 mm and height is 150 mm.	 <p data-bbox="946 1424 1362 1447">FIGURE 2 - BASE FOR 12" INSET LIGHTS</p>

## 2.2 INSTALL A LIGHT IN A BASE

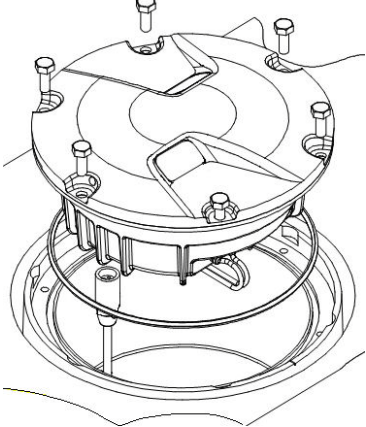
Install a light	Image example
<ul style="list-style-type: none"><li>(a) Check and clean the contact surface of the base receptacle, especially the groove for o-ring gasket.</li><li>(b) Place the o-ring gasket to the groove in the base receptacle and connect the secondary connectors.</li><li>(c) Using lifting hooks, place the luminaire to the base receptacle. Make sure that the o-ring gasket and cable settle well into the base.</li><li>(d) Align light channels parallel to aiming grooves in the base receptacle.</li><li>(e) Screw the fastening bolts M10x25 first by hand. By using a torque wrench fasten the bolts gradually crosswise in a sequence to a torque of <b>40 Nm</b>.</li><li>(f) Connect the secondary cable to the isolating transformer in the transformer pit.</li><li>(g) Connect and test the light is operational</li></ul>	 <p data-bbox="989 784 1340 817">FIGURE 3 – LIGHT INSTALLATION</p>



### 3. MAINTENANCE

#### 3.1 BEFORE YOU START



***WARNING!*** MAKE SURE YOU HAVE READ AND UNDERSTOOD SAFETY INSTRUCTIONS ON PAGE 3.

##### 3.1.1 Light pressure

Depressurize the light using the valve in the inner cover immediately before maintenance due to:

- The light may contain pressure due to high internal temperature as it has been on for a long period of time immediately before maintenance.
- If the light cover is hot, there is probably pressure inside the light.
- If the latch mechanism feels abnormally tight this means there is a risk for pressure inside the light.

##### 3.1.2 Handle with care and clean

It is important to handle with care and clean to maximize the light and component lifetime and minimize maintenance.

- Do not touch the glass bulb or the reflecting surface of the lamp with bare hands as this can shorten the expected lifetime of the lamp.
- Use a soft, clean and dry rag when cleaning, handling or maintaining the optical parts of the light.
- When any maintenance procedures are carried out, remove all possible dust and moisture from the inside of the base, inner cover and top cover.
- All sealing mating surfaces must be thoroughly cleaned before reassembling.

### 3.2 REPLACE A LIGHT IN A BASE

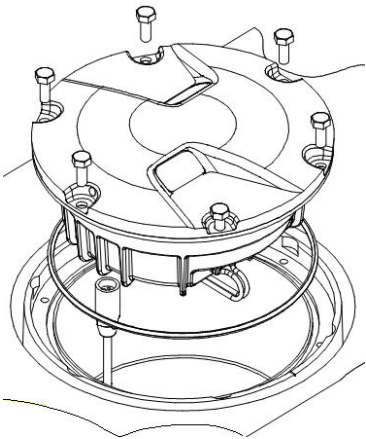
Replace a light	Image examples
<p><b>Note:</b> Make sure you have read and understood Safety Instructions on page 3.</p>	
<p><b>Remove a light from a base</b></p>	
<p>(a) Clean the outer surface of the top cover.            (b) Unfasten the six bolts securing the top cover.            (c) Use the lifting hooks to lift the top cover from the base receptacle.            (d) Disconnect the secondary cable.</p>	 <p data-bbox="925 851 1404 929">FIGURE 4 – LIFTING HOOKS TO REMOVE AND INSTALL LUMINAIRE FROM THE BASE RECEPTACLE</p>
<p><b>Install a light in a base</b></p>	
<p>(e) Check and clean the contact surface of the base receptacle, especially the groove for o-ring gasket.            (f) Place the o-ring gasket to the groove in the base receptacle and connect the secondary connectors.            (g) Using lifting hooks, place the luminaire to the base receptacle. Make sure that the o-ring gasket and cable settle well into the base.            (h) Align light channels parallel to aiming grooves in the base receptacle.            (i) Screw the fastening bolts M10x25 first by hand. By using a torque wrench fasten the bolts gradually crosswise in a sequence to a torque of <b>40 Nm</b>.            (j) Connect the secondary cable to the isolating transformer in the transformer pit.            (k) Connect and test the light is operational</p>	 <p data-bbox="989 1467 1340 1500">FIGURE 5 – LIGHT INSTALLATION</p>

### 3.3 WORKSHOP MAINTENANCE

It is important to always make sure that the light is depressurized before disassembly for maintenance work.



**Note:** Make sure you have read and understood Safety Instructions on page 3.

Only the most common maintenance procedures are instructed in the following paragraphs. Construction of the luminaire allows that it can be fully disassembled and all the parts can be replaced if needed.

#### 3.3.1 Pressure release

The light includes a valve component according to standard automotive tubeless valve design for common pressure gauges. The valve is loosened to release pressure during maintenance and tightened after assembly for testing, before use in the field.

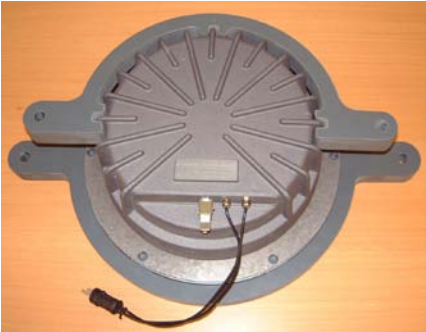
#### 3.3.2 Disassemble a light cover

Disassemble a light cover	Image examples
<p><b>Note:</b> Make sure you have read and understood Safety Instructions on page 3.</p>	
<ul style="list-style-type: none"> <li>(a) Fasten the stationary tool (bigger) to a bench plastic side upwards.</li> <li>(b) Place the luminaire upside down on the tool, which prevents the top cover from rotating.</li> <li>(c) Lock the seal integrity testing valve open with a bleeding nozzle.</li> <li>(d) Attach the c-shaped tool to inner cover plastic side against it.</li> <li>(e) Turn the inner cover counter-clockwise with respect to the top cover until the holes for fastening bolts in the top cover cannot be seen through the holes in the inner cover.</li> </ul>	 <p style="text-align: center;">FIGURE 6 – OPENING THE INNER COVER</p>
<ul style="list-style-type: none"> <li>(f) Place the removal pliers to slots in top cover and press to separate the inner cover from top cover. If covers are not separated completely at once, move the pliers to flat surface beside the slot and press again.</li> <li>(g) Lift the inner cover straight up.</li> </ul>	 <p style="text-align: center;">FIGURE 7 – REMOVING THE INNER COVER</p>

### 3.3.3 Assemble a light cover

Assemble a light cover	Image example
<ul style="list-style-type: none"><li>(a) Always replace the O-ring gasket of the inner cover when a light is opened for maintenance.</li><li>(b) Before replacing the inner cover, apply lubricant to the O-ring and/or top cover sealing mating surface. This eases replacement considerably and extends the lifetime of the O-ring.</li><li>(c) Place the inner cover on top of the top cover so that the studs pass through the openings in the fastening plates.</li><li>(d) Fit the bleeding nozzle to the seal integrity testing valve to keep the needle open and press the inner cover downwards until the flange meets the top cover.</li><li>(e) Turn the inner cover clockwise with respect to the top cover until the holes for fastening bolts in top and inner covers are fully aligned.</li><li>(f) Remove the bleeding nozzle.</li></ul>	 <p data-bbox="935 763 1394 786">FIGURE 8 – ASSEMBLING THE INNER COVER</p>

### 3.3.4 Seal integrity test

The luminaire can be easily tested for seal integrity as completely assembled with secondary cable through the metal valve installed to the inner cover. The valve is standard automotive tubeless valve and commonly available pressure gauges with pressure release function for automotive tyres can be used for testing. Before testing make sure that the inner cover is properly closed. This is the case when the flange of the inner cover meets with the top cover and when the holes for base receptacle fastening bolts are completely aligned with respect to each other (so that M10x25 bolt can run through). As an additional safety measure before pressurising the luminaire for test, it is advised to install three (3) pieces of M10x25 bolts, 120 degrees apart from each other, through the luminaire fastening holes and install suitable nuts for the bolts. The nuts should be tightened in a hand tightening torque. This is done to minimise the safety hazard against pressured air equipment faults or unintentional misuse of pressured air equipment.



***WARNING! NEVER EXCEED TESTING PRESSURE OF 1.5 BAR. THE LIGHT IS NOT DESIGNED TO WITHSTAND PRESSURES HIGHER THAN 1.5 BAR.***

Fit the pressure gauge to the valve and put the luminaire into water container so that the whole luminaire is covered by water. Gradually increase the pressure to the maximum testing pressure of 1,5 bar (150 kPa). Keep the luminaire in water for couple of minutes and inspect for air leaks. If leaks exist it is necessary either reassemble the luminaire, tighten the cable gland or change the gasket or o-ring gasket depending on the leak position.

### 3.3.5 Replace a lamp in a light

Replace a lamp in a light	Image examples
<p>(a) Disassemble the light, see 3.3.2 Disassemble a light cover on page 9.</p> <p>(b) Disconnect the lamp wires from the terminal strip by pulling them straight out. <b>Note:</b> <i>Do not bend the connectors nor loosen the terminal strip screws.</i></p> <p>(c) If there are PTFE protection hoses on the lamps, remove those from the wires of the old lamp.</p> <p>(d) To remove the lamp, first push the lower locking pin from behind to release the lamp fastener and turn it counter-clockwise to remove the lamp.</p> <p>(e) Take the new lamp and remove the white or clear protection hoses around the connectors by splitting them.</p> <p>(f) Install the longer PTFE protection hoses earlier removed from the old lamp to the wires of the new lamp.</p> <p>(g) Pass the wires through the hole in the lamp holder and place the lamp.</p> <p>(h) Turn the lamp fastener clockwise and press the pin from behind.</p> <p>(i) Guide the fastener opening to the pin and release it to lock the fastener.</p> <p>(j) Rotate the lamp so that the arrow on the lamp reflector is pointing upwards and check that the lamp has settled properly to the holder.</p> <p>(k) Connect the lamp wires to the round male connectors in the terminal strip and slide the PTFE protection hoses on top of the connectors.</p>	 <p>FIGURE 9 – REMOVING A LAMP</p>

### 3.3.6 Remove/insert prisms and a prism gasket

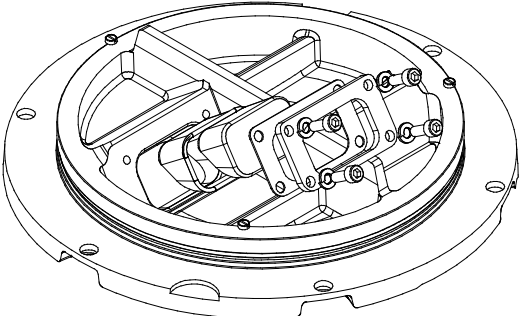
Remove prisms and a prism gasket	Image example
<ul style="list-style-type: none"> <li>(a) Disassemble the light, see 3.3.2 Disassemble a light cover on page 9.</li> <li>(b) Unfasten the screws securing the prism fastening plate.</li> <li>(c) Remove the fastening plate and prism protection plate.</li> <li>(d) Remove the prism and gasket from the top cover by pressing them inwards to the luminaire.</li> </ul>	
<p><b>Insert prisms and a gasket</b></p> <ul style="list-style-type: none"> <li>(a) Clean the gasket mating surfaces in the top cover and the new gasket.</li> <li>(b) Apply a thin layer of high temperature resistant grease on the surface of the prism.</li> <li>(c) Insert the prism about halfway through to the gasket and apply some grease on top of the gasket.</li> <li>(d) Install the gasket with prism to the top cover so that the o-ring shaped edge of the gasket settles well to the chamfer around the prism opening in the top cover.</li> <li>(e) Press the prism to the top cover with thumbs as much as possible.</li> <li>(f) Install the prism protection plate and fastening plate and tighten the screws crosswise until the protection plate meets with the surface of the top cover.</li> <li>(g) Using a thin sharp knife cut the surplus gasket around the prism opening from the outside of the luminaire.</li> <li>(h) Clean the visible surfaces of the prism from any possible grease or fingerprints using soft damp cloth (mild soap water or glass cleaner can be used provided that no residues will remain).</li> <li>(i) Reassemble the cover. See 3.3.3 Assemble a light cover on page 10.</li> </ul>	

### 3.3.7 Replace an o-ring gasket

It is recommended to change the o-ring gasket simultaneously with lamp replacement. Perform a seal integrity test for the assembled luminaire.

Replace an o-ring gasket	Image example
<ul style="list-style-type: none"><li>(a) Disassemble the light, see 3.3.2 Disassemble a light cover on page 9.</li><li>(b) Remove the old o-ring gasket, but be careful not to damage the surfaces in top cover.</li><li>(c) Clean properly the sealing surfaces in the inner and top cover.</li><li>(d) Install the new o-ring gasket to the groove.</li><li>(e) Apply high temperature resistant grease to the o-ring vertical mating surface in the inner cover to ease the operation.</li><li>(f) Close the inner cover as described in 3.3.3 Assemble a light cover on page 10.</li></ul>	 <p data-bbox="927 857 1310 882">FIGURE 11 – O-RING REPLACEMENT</p>

## 3.4 TECHNICAL INFORMATION

### 3.4.1 Storage

The light is designed for outdoor operation, however storing the light outside without using it is a risk for damage to light components. For a longer storage time (more than a week), it is recommended to store the light indoors in a dry and dust free environment and at room temperature (warm or cool). Proper storage ensures trouble free replacement procedures. It is strongly recommended not to store any electrical equipment outside.

### 3.4.2 Daily function check for installed equipment

If the equipment is installed, but not in operation or intended to be used for a longer period of time (more than one week), it is recommended to perform a daily function check to ensure system availability in case of urgent need.

A daily function check is referred to in the document:

ICAO, Airport Services Manual Part 9, Airport Maintenance Practice and FAA AC 150/5340-26A, Maintenance of airport visual aids facilities.

### 3.4.3 Specification

- ICAO Annex 14 Volume I 5<sup>th</sup> edition 2009.
- Aerodrome Design Manual Part 4 Visual Aids, 4<sup>th</sup> edition 2004.

### 3.4.4 Application

- Bidirectional runway centre line inset light, clear
- Bidirectional runway centre line inset light, clear/red



### 3.4.5 Technical characteristics

Characteristic	Description
<b>Light dimensions</b>	Protrusion 12.7 mm Diameter 326 mm Depth 150 mm
<b>Weight</b>	6.7 kg 11.6 kg with base receptacle
<b>Ingression Protection</b>	IP67
<b>Materials</b>	Top cover, inner cover and base receptacle: aluminium alloy Sheet metal fastening parts and fixing hardware: stainless steel Gaskets: silicone rubber
<b>Surface treatment</b>	Anodising on aluminium alloy parts
<b>Cables and connectors</b>	Plugs: FAA L-823 Style 6 Receptacles: FAA L-823 Style 12 Secondary cable: FAA 150/5345-70
<b>Light sources</b>	2x48W, 6,6A, Ø50 mm dichroic halogen lamp with 130 mm wires and Ø4 mm round female connectors. Average lifetime 1000 hours at rated current.
<b>Packing</b>	Dimensions: 340x340x145 mm Weight: 6.8 kg
<b>Accessories</b>	Alignment device IDM 4306 Lifting hooks Maintenance tool set

For more information, contact Safegate Group or see [www.safegate.com](http://www.safegate.com).

### 3.5 SUPPORT

Our experienced engineers are available for support and service at all times, 24 hour/7 days a week. They are part of a dynamic organization making sure the entire Safegate Group is committed to minimal disturbance for airport operations.

Safegate Group Support	
<p>Safegate Group knows that our equipment is used in one of the busiest industries in the world, where down-time costs money and creates delays for airlines and their passengers. As one of the world's leading suppliers of airport systems, Safegate Group is committed to ensuring that our customers are able to get the most out of your equipment, regardless of the location or the time of day. For this reason, Safegate Group has established the Safegate Group Support service.</p> <p>Safegate Group Support is a unique service provided by Safegate Group to our customers, free of charge during the warranty period or as a service contract. Any time of day, any day of the year, a Safegate Group engineer is on standby to answer questions and assist with any problems that may arise. Qualified technical assistance is just a phone call or an e-mail away, 24-7 worldwide.</p> <p>✉ <a href="mailto:support@safegate.com">support@safegate.com</a></p> <p>☎ +46 40 699 1740</p>	 

#### 3.5.1 Safegate Group Website

The Safegate Group Website, [www.safegate.com](http://www.safegate.com), offers information regarding our airport solutions, products, company, news, links, downloads, references, contacts and more.

**Note:** There is also a **Client/Partner login** area for the latest information and updates, if available.

## 3.6 RE-CYCLING

### 3.6.1 Local Authority Re-cycling

The disposal of Safegate Group products is to be made at an applicable collection point for the recycling of electrical and electronic equipment. The correct disposal of equipment prevents any potential negative consequences for the environment and human health, which could otherwise be caused by inappropriate waste handling. The recycling of materials helps to conserve natural resources. For more detailed information about recycling of products, contact your local authority city office.

### 3.6.2 Safegate Group Re-cycling

Safegate Group is fully committed to environmentally-conscious manufacturing with strict monitoring of our own processes as well as supplier components and sub-contractor operations. Safegate Group offers a re-cycling program for our products to all customers worldwide, whether or not the products were sold within the EU.

Safegate Group products and/or specific electrical and electronic component parts which are fully removed/separated from any customer equipment and returned will be accepted for our recycling program.

All items returned must be clearly labelled as follows:

- For ROHS/WEEE Re-cycling
- Sender contact information (Name, Business Address, Phone number).
- Main Unit Serial Number.

Safegate Group will continue to monitor and update according for any future requirements for EU directives as and when EU member states implement new regulations and or amendments. It is our aim to maintain our compliance plan and assist our customers.

**Note:** For more information, see [www.safegate.com](http://www.safegate.com), or contact Safegate Group Support via email at [support@safegate.com](mailto:support@safegate.com) or phone +46 40 699 1740.

## 3.7 SPARE PARTS

Spare parts are available for Airfield Lighting. For more information see the Spare Parts List document.

**Note:** Contact Safegate Group for assistance with ordering spare parts.

# Check in to the future

How many aircraft can your airport handle today?  
Can this number be increased without adverse effects on the airport's safety level?  
It is a known fact that traffic volume will rise in the foreseeable future. More movements will demand monitoring of the entire airport. Requirements will be sharpened and the development of an integrated system

controlling not only ground movements but also air traffic close to the airport is of the highest interest.  
The International Civil Aviation Organization (ICAO) already describes A-SMGCS, Advanced Surface Movement Guidance and Control System, as the answer to the future modern airport need to control the entire airport space in one superior system.

To a larger extent than today's systems, A-SMGCS will rely on automated processes to give both pilots and traffic controllers exact information about positions and directions. Safegate Group delivers complete A-SMGCS solutions already, as well as all vital parts relating to it. Safegate Group can check your airport into the future – today!

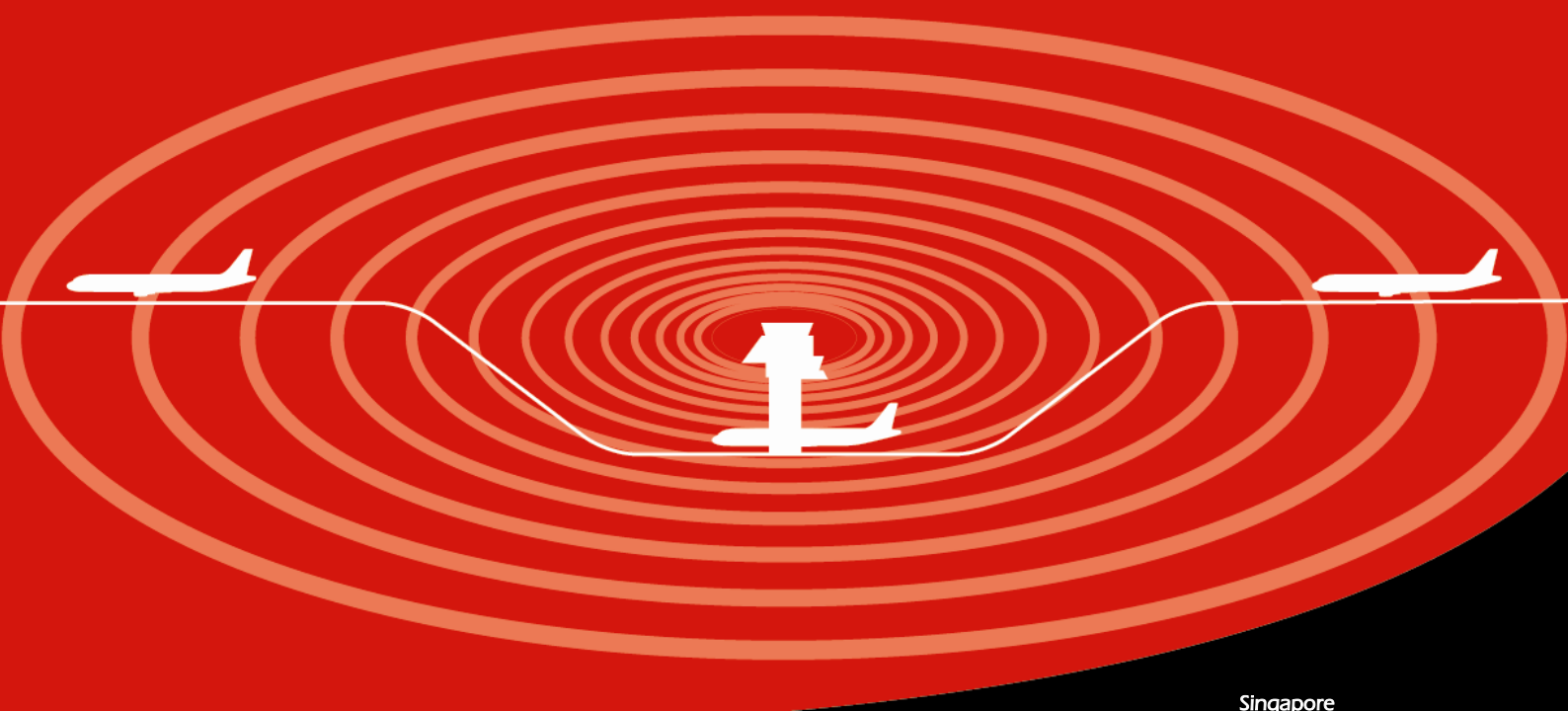

**Safegate Group HQ**  
Djurhagegatan 19  
SE-213 76 Malmö, Sweden  
Phone: +46 (0)40 699 17 00  
Fax: +46 (0)40 699 17 30  
E-mail: [market@safegate.com](mailto:market@safegate.com)

**Australia**  
[australia@safegate.com](mailto:australia@safegate.com)  
+61 (0)3 9720-3233

**China**  
[china@safegate.com](mailto:china@safegate.com)  
+8610-85275297

**Dubai**  
[dubai@safegate.com](mailto:dubai@safegate.com)  
+971 4 332 30 07

**Finland**  
[finland@safegate.com](mailto:finland@safegate.com)  
+358 (0)20754 7700

**France**  
[france@safegate.com](mailto:france@safegate.com)  
+33 (0)1 49 53 62 62

**Germany**  
[germany@safegate.com](mailto:germany@safegate.com)  
+49 (0)231 9776754

**India**  
[india@safegate.com](mailto:india@safegate.com)

**Qatar**  
[qatar@safegate.com](mailto:qatar@safegate.com)  
+974 436 9628

**Russia**  
[russia@safegate.com](mailto:russia@safegate.com)  
+7 495 917 4614

**Singapore**  
[singapore@safegate.com](mailto:singapore@safegate.com)  
+65 6289 6893

**Spain**  
[spain@safegate.com](mailto:spain@safegate.com)  
+34 917 157 598

**UK**  
[uk@safegate.com](mailto:uk@safegate.com)  
+44 (0)20 8594 2747

**USA**  
[usa@safegate.com](mailto:usa@safegate.com)  
+1 763 535 92 99

**THORN** **IDMAN**  
Airfield Lighting

**SAFEGATE**  
GROUP 

Safegate Group offers solutions for increased safety, efficiency and environmental benefits to airports around the world. The company was founded in 1973 and has its headquarters in Malmö, Sweden. Safegate Group has over 70 partners around the globe in order to be close to its customers. The latest members of Safegate Group, Thorn AFL and Idman, have both over 40 years of experience in airfield lighting solutions for airports and heliports worldwide. Safegate Group's complete range of products and services, a "one-stop shop", provides solutions to customers and airborne travellers around the globe.

For more contact information and details:  
[www.safegate.com](http://www.safegate.com)