

RELIANCE

LED PAPI / APAPI

Precision Approach Path Indicator



ADB SAFEGATE
RELIANCE

Compliance with Standards

FAA:	L-880(L) / L-881(L) AC 150/5345-28 (Current Edition). ETL Certified.
ICAO:	PAPI / APAPI Annex 14, Volume 1 (Current Edition)
T/C:	PAPI / APAPI Transport Canada TP 312 par. 5.3.16.12 and Appendix 5B, Figure B-19
EASA:	CS ADR-DSN.M.645
MOS:	Part 139, para. 9.9.4.6
CE:	DIRECTIVE 2014/35/EU: LVD annex IV & with DIRECTIVE 2014/30/EU: EMC annex IV
Rosaviation/IAC:	AP-170 (Aviation rules. Part 170)

Uses

The RELIANCE™ LED PAPI (Precision Approach Path Indicator) system uses a multi-LED array to form a single light channel on each light unit to provide the pilot precise visual information, enabling the approach procedure to be performed with the utmost accuracy and safety.

Type L-880(L) PAPI system consists of four light units located at the side of the runway adjacent to the origin of the glide path. The nominal glide slope angle is midway between the angular settings of the central pair of the four units. If an aircraft is on the correct approach path, the pilot will see two red and two white light indicators. If the aircraft approach is too high, an increased number of white light indicators will be seen. If the approach is too low, the pilot will note an increased number of red light indicators.

Type L-881(L) APAPI system is an abbreviated PAPI system. It is identical to the L-880(L) PAPI system, except it consists of only two light units (instead of four). The nominal glide slope is midway between the angular settings of the two units, and when the pilot is on or close to the correct approach path, the unit nearest the runway will be seen as red and the other unit as white.

Style A (voltage powered) system is for use with 120 VAC or 240 VAC, 50/60 Hz voltage input. Style B (current powered) system is for use with 6.6 A or 20 A, 50/60 Hz series current input from a CCR.

An electronic inclinometer assembly, which is a mercury-free device, is provided on each light unit to monitor the aiming angle of the light unit. FAA certified PAPIs are designed to de-energize all light units if the optical pattern of any light unit is raised more than 0.5° or lowered more than 0.25° with respect to the set aiming angle of the light unit (refer to AC 150/5345-28H). For ICAO and TP312 compliant

units, this feature is factory disabled, but can easily be enabled if desired.

Features

- LEDs greatly increase light source life and significantly reduce ongoing maintenance costs and periodic relamping expenses.
- Average LED life of 60000 hours under high-intensity conditions and more than 150000 hours under typical operating conditions.
- Each light unit uses a maximum 120 W when the heater is active.
- Depending on operating mode, light unit uses 62% to 80% less energy than traditional light units that use three 105 W lamps, two 200 W lamps or three 200 W lamps.
- Unique, sealed optical chamber is designed to prevent dew/frost on LED optical elements.
- Low-power design contributes to a lower life cycle cost and lower cost for CCRs and supporting equipment.
- Use of LED light source improves safety and pilot recognition by eliminating color shifts typical of incandescent light sources at lower intensity settings.
- Digitally controlled heated front glass ensures that the glass is clear of frost/dew within:
 - 3 minutes when ambient: -6 °F to +131 °F (-21 °C to +55 °C)
 - 4 minutes when ambient: -38 °F to -8 °F (-39 °C to -22 °C)
 - 5 minutes when ambient: -67 °F to -40 °F (-55 °C to -40 °C)
- Hardened front glass protects the optical lens from sandblast.
- Voltage powered systems do not require a separate controller cabinet. Controller functionality is incorporated into the Primary Light Unit. This minimizes installation costs and is compliant with FAA Safety Management System requirements to clear the Runway Safety Areas (RSA) and Runway Obstacle Free Areas (ROFA) of all unnecessary obstacles. Operates on an input voltage of 240 VAC +/-10%, 50-60 Hz and can easily be field configured to operate on 120 VAC +/-10%, 50/60 Hz.
- Current powered systems operate on either a 3 or 5-step CCR designed in compliance with IEC or FAA requirements
- A unique digital display indicating the vertical angle can be read from outside the light unit. This eliminates the need to use a manual aiming device during initial installation and for routine verification of vertical angle setting, minimizing maintenance time.

RELIANCE

- In the event of a tilt, the digital display indicates which light unit has tilted along with status indicators and horizontal angle. This allows for quick troubleshooting, minimizing the maintenance effort needed to determine which light unit is tilted.
- Light units may be aimed at any vertical angle up to 10°
- Rugged lightning protection complies with ANSI/IEEE C62.41- 1991 Location Category C2 given in FAA Eng. Brief 67. Category C2 is defined as a 1.2/50µS – 8/20 µS combination wave, with a peak voltage of 10,000 V and a peak current of 5,000 A.
- For voltage powered systems, a photoelectric control on the primary light unit automatically provides full intensity during the day and a reduced intensity (5% or 20% of full intensity) at night. A circuit breaker is provided to permit the input power to be de-energized for field maintenance.
- Includes an integral deflection plate on the top front edge of the light unit cover to prevent the pilot from seeing reflected light from the top of the light unit during approach.
- Body is painted black. Top cover is painted aviation orange for FAA systems and aviation yellow for ICAO/TP 312 systems.
- A set of waterproof cables and connectors are provided to allow for a fast, reliable installation of each PAPI unit.
- Meets both FAA Class I and Class II temperature ranges:
 - Class I: -31 °F to +131 °F / -35 °C to +55 °C
 - Class II: -67 °F to +131 °F / -55 °C to +55 °C
- Protection class IP55.

Power Supply

For Style A (Voltage Powered) systems, power is supplied to the primary light unit. For Style B (Current Powered) systems, power is supplied individually to each light unit via a 6.6/6.6 A or 20/6.6 A, 200 W isolation transformer.

Style A (Voltage Powered)	
Input Voltage	240 VAC ±10%, 50/60 Hz or 120 VAC ±10%, 50/60 Hz ¹
L-880(L) PAPI (4 box):	528 VA max
L-881(L) APAPI (2-box):	264 VA max
Style B (Current Powered)	
Input Current	6.6 A or 20 A Series Circuit
L-880(L) PAPI (4-box) Total CCR Load:	630 VA max ²
L-881(L) APAPI (2-box) Total CCR Load:	330 VA max ²

Notes

¹ Source power maximum 305 m (1000 ft) away using 6 mm² (AWG 10) wire.

² Includes PAPI light units and isolation transformers.

Operation/Control Mode

Multiple remote control options are available that maximize operational flexibility and minimize energy usage

Option	Operation/Control Mode	Description
1	Style A (Voltage) Operation, Current Sensing Night Control Mode	Powered from a continuous source 120 or 240 VAC, 50/60Hz. Day/Night mode is determined by the photocell. Day mode (100% light) is always active during daytime (no current sensing). Night mode (5 or 20% light) is only active during nighttime and when current is detected.
2	Style A (Voltage) Operation, Current Sensing Day/Night Control Mode	Powered from a continuous source 120 or 240 VAC, 50/60Hz. Day/Night mode is determined by the photocell. Day mode (100% light) is active during daytime when current is detected. Night mode (5 or 20% light) is active during nighttime and when current is detected.
3	Style A (Voltage) Operation, External On/Off Control Mode	Powered from a continuous source 120 or 240 VAC, 50/60Hz. Day/Night mode is determined by the photocell. Day mode (100% light) is always active during daytime. Night mode (5 or 20% light) is active during nighttime. External controlling device provides On/Off control of the system.
4	Style A (Voltage) operation, No Control Mode or Style B (Current) Operation, CCR Control Mode	Style A (Voltage) is powered from a continuous source 120 or 240 VAC, 50/60Hz. Day/Night mode is determined by the photocell. Day mode (100% light) is always active during daytime. Night mode (5 or 20% light) is always active during nighttime. No On/Off control of the system. Style B (Current) is powered from a 3-step CCR (4.8 A to 6.6 A) or a 5-step CCR (2.8 A to 6.6 A, 50/60 Hz). Light unit intensity is controlled by CCR setting. An optional configuration is available for no light output on steps B1, B2 of a 5-step CCR (heated front glass remains active to keep it clear of dew/frost). Operating range is field programmable. The heater is active at all steps. Light output is activated after initial front glass heat-up period is complete (up to 3 minutes for Temperature Class I and up to 5 minutes for Temperature Class II) or instantly for FAA applications.

RELIANCE

Contractor Kit

AK00031 - - 01

Power

- A = Style A (Voltage)
- B = Style B (Current)
- R = Style B (Current) with Redundant

Type

- 2 = 2 Light Units L-881(L) APAPI
- 4 = 4 Light Units L-880(L) PAPI

Power Cord

- 1 = 8 ft (2.4 m) (standard)
- 2 = 18 ft (5.5 m)

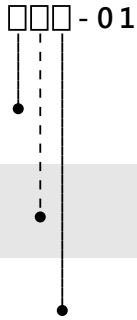

Dimensions

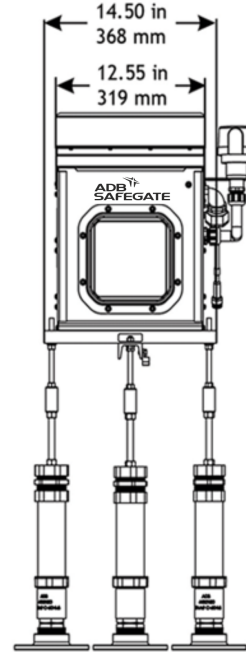

Optional Touchpad Cover

44A7564

Optional touchpad cover provides added protection for the LED display. See user manual for installation instructions.

Packaging

Weight per 2 Box System	240-280 lb (109-127 kg)
Weight per 4 Box System	420-460 lb (191-209 kg)
Pallet Dimensions 2 Box System (LxWxH)	65 x 42 x 27 in (1651 x 1067 x 686 mm)
Pallet Dimensions 4 Box System (LxWxH)	65 x 42 x 48 in (1651 x 1067 x 1219 mm)

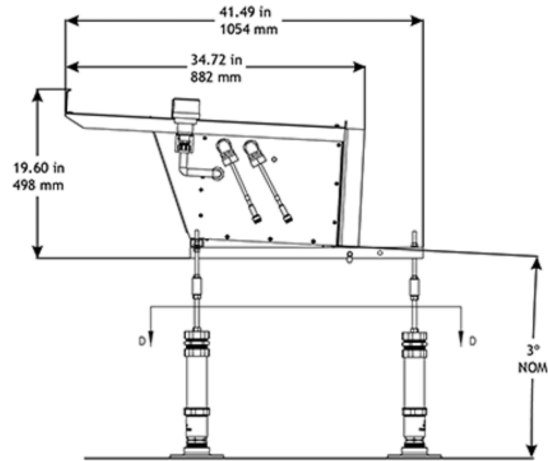

www.adbsafegate.com

Product specifications may be subject to change, and specifications listed here are not binding. Confirm current specifications at time of order.