

# Airfield Lighting

Spare Part List

Unidirectional High-Intensity Elevated Light  
(IDM 6301)

- Elevated Runway Guard Light



**Note:** *This page is blank for convenient double-sided printing.*

**SPARE PART LIST**  
**UNIDIRECTIONAL HIGH-INTENSITY ELEVATED LIGHT**  
**(IDM 6301)**

*Note: Contact Safegate Group for assistance with ordering spare parts.*

No.	Description	No.	Quantity	Code	Note
1	<b>Housing</b>	1, 8, 20, 21, 22	2, 1, 2, 4, 2	15591	
2	<b>Reflector</b> (f=10)	2		10360	
3	<b>Gasket</b>	4	1	10323	
4	<b>Front glass</b> , yellow	5	1	10322	
5	<b>Bowl fastening ring</b>	6	1	10317	
6	<b>Screw</b> , Cross slot sunk screw M5x20 A4	7		19196	Pack of 100 pcs.
7	<b>IDM 6301 Adapter with cable</b>	16		10166	
8	<b>IDM 6301 ADAPTER</b> incl CABLE and GLAND	17, 9, 14, 16, 18, 15	1	19197	
9	Screw M4x8 A4 DIN 7985	3		19198	Pack of 100 pcs.
10	<b>Hex screw M8x16 A4 DIN 933</b>	10		19199	Pack of 100 pcs.
11	<b>Washer M8 A4 DIN 125</b>	11		19202	Pack of 100 pcs.
12	<b>Hex screw M6x16 A4 DIN 933</b>	12		19200	Pack of 100 pcs.
13	<b>Washer M6 A4 DIN 125</b>	13		19203	Pack of 100 pcs.
14	<b>Screw M8x20, A4</b>	14		19201	Pack of 100 pcs.
15	<b>PLASTIC COVER TUBE</b>	-	1	10364	
16	<b>Frangible coupling</b> , type 3	19	1	11555	
17	<b>Lamp</b> Pk30d 45 W, 6.6 A <b>Lamp</b> Pk30d 100 W, 6.6 A	23	1	11991 11988	
18	<b>Sun Shield for IDM 6301</b>	-	1	11956	
19	<b>Stone shield</b>	-	1	16575	
20	<b>O-Ring 62x3mm kit</b>	-		19195	Pack of 10 pcs.

*Note: Component availability or design may be subject to change due to unforeseen circumstances. This document is subject to change or new information from Safegate Group, as and when available or if required, with reservation for error or price changes. For more information, contact Safegate Group or see [www.safegate.com](http://www.safegate.com).*

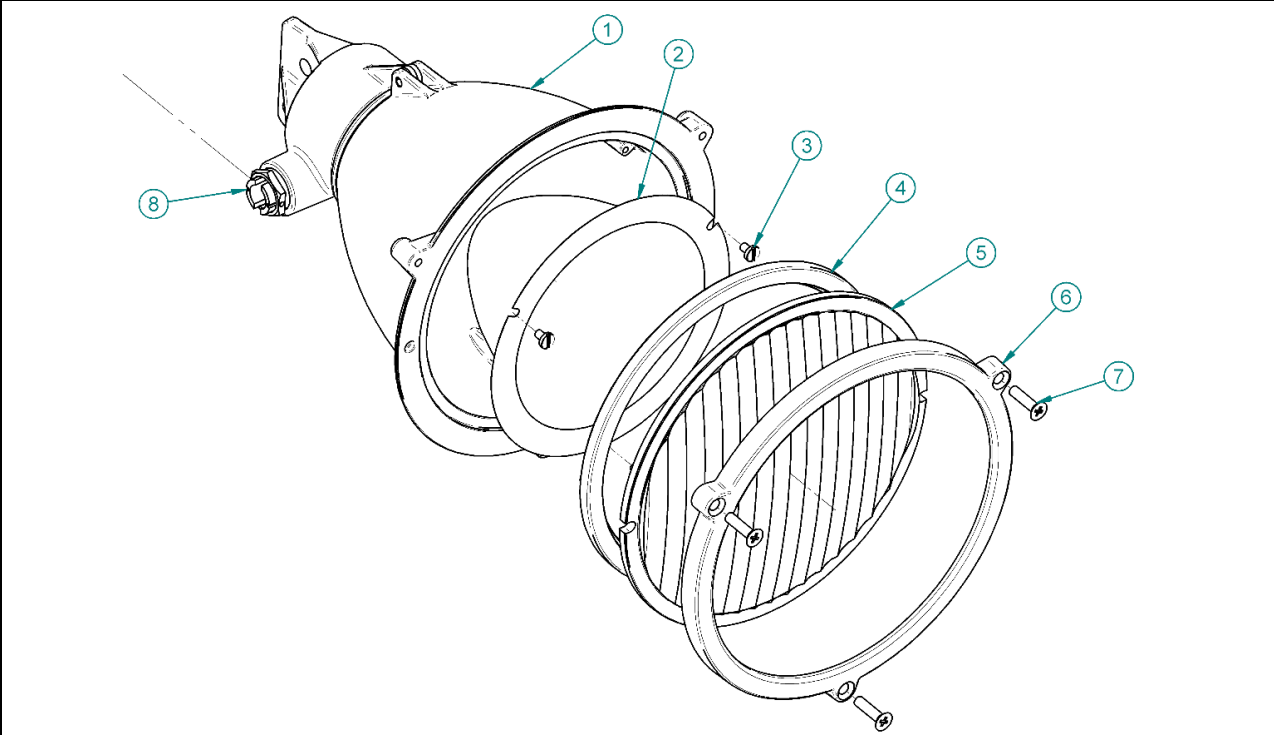

FIGURE 1

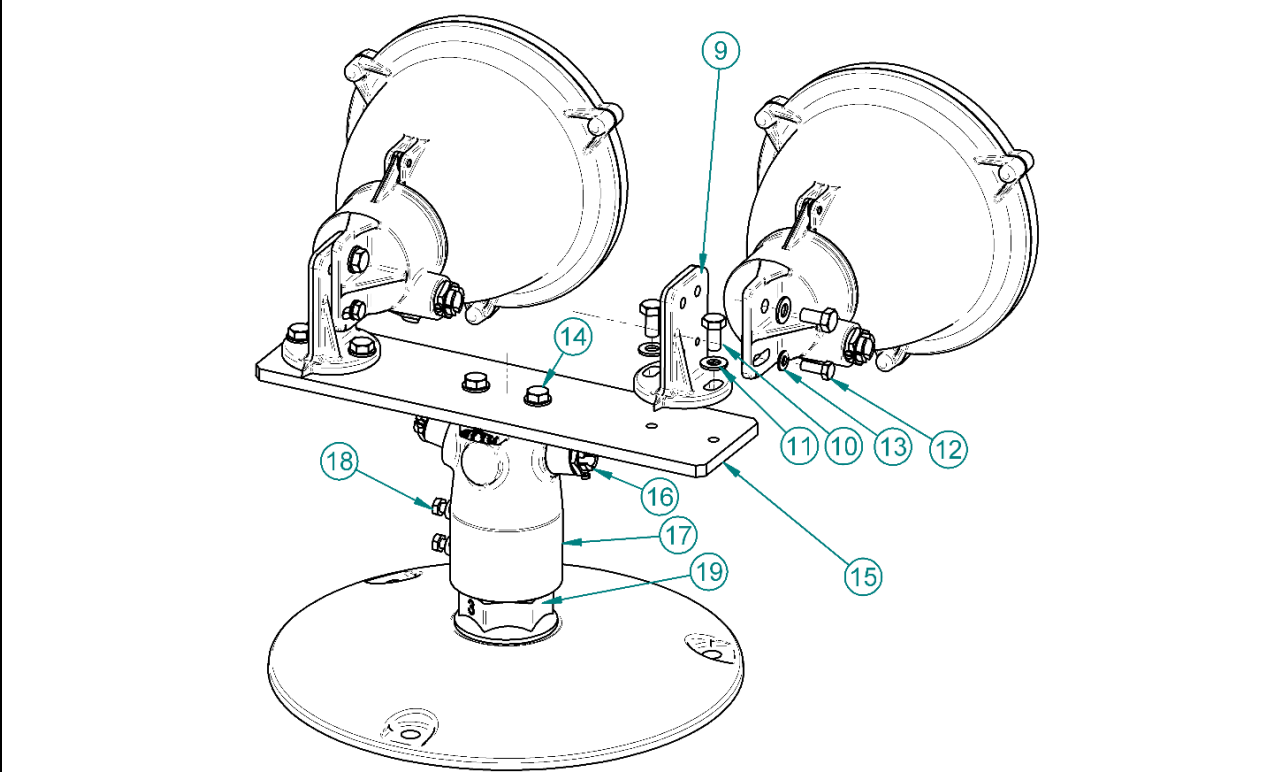

FIGURE 2

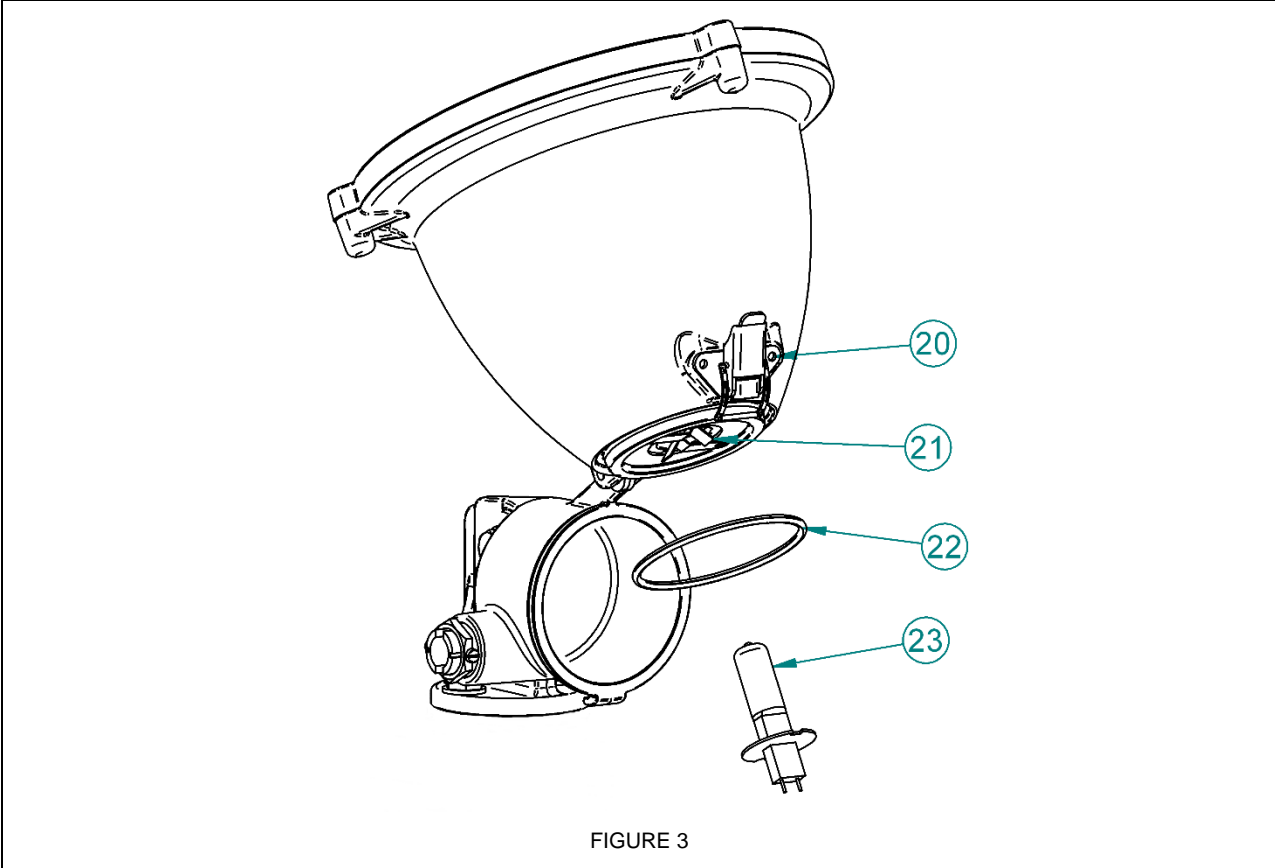

FIGURE 3

# Check in to the future

How many aircraft can your airport handle today? Can this number be increased without adverse effects on the airport's safety level? It is a known fact that traffic volume will rise in the foreseeable future. More movements will demand monitoring of the entire airport. Requirements will be sharpened and the development of an integrated system

controlling not only ground movements but also air traffic close to the airport is of the highest interest. The International Civil Aviation Organization (ICAO) already describes A-SMGCS, Advanced Surface Movement Guidance and Control System, as the answer to the future modern airport need to control the entire airport space in one superior system.

To a larger extent than today's systems, A-SMGCS will rely on automated processes to give both pilots and traffic controllers exact information about positions and directions. Safegate Group delivers complete A-SMGCS solutions already, as well as all vital parts relating to it. Safegate Group can check your airport into the future – today!



**Safegate Group HQ**  
Djurhagegatan 19  
SE-213 76 Malmö, Sweden  
Phone: +46 (0)40 699 17 00  
Fax: +46 (0)40 699 17 30  
E-mail: market@safegate.com

**Australia**  
australia@safegate.com  
+61 (0)3 9720-3233

**Austria**  
office@avibit.com  
+43 316 429961

**Brazil**  
brazil@safegate.com  
+55 11 2137 4405

**China**  
china@safegate.com  
+8610-85275297

**Dubai**  
dubai@safegate.com  
+971 4 452 75 75

**Finland**  
finland@safegate.com  
+358 (0)20754 7700

**France**  
france@safegate.com  
+33 (0)1 42 99 60 40

**Germany**  
germany@safegate.com  
+49 (0)4121 464 303

**India**  
india@safegate.com  
+91 11 4106 1545

**Malaysia**  
malaysia@safegate.com  
+60 32 011 3522

**Qatar**  
qatar@safegate.com  
+974 436 9628

**Russia**  
russia@safegate.com  
+7 495 917 4614

**Singapore**  
singapore@safegate.com  
+65 6289 6893

**Spain**  
spain@safegate.com  
+34 917 157 598

**UK**  
uk@safegate.com  
+44 (0)208 573 0384

**USA**  
usa@safegate.com  
+1 763 535 92 99

**SAFEGATE**  
GROUP 

*Safegate Group offers solutions for increased safety, efficiency and environmental benefits to airports worldwide. The company was founded in 1973 and has its headquarters in Malmö, Sweden. Safegate Group has more than 70 partners around the globe in order to be close to its customers. Earlier members of Safegate Group include Thorn AFL and Idman, who both have over 40 years of experience in airfield lighting solutions for airports and heliports. The latest member of Safegate Group is Avibit, a leading provider of next generation software applications and integration of efficient air traffic control systems. Safegate Group's complete range of products and services, a "one-stop shop", provides solutions to customers and airborne travellers around the globe.*

[www.safegate.com](http://www.safegate.com)