

# TAXIWAY LIGHTING

## SL-TE-I, SL-SG-I

Omnidirectional Taxiway Edge and Aircraft Stand Maneuvering 8" inset light

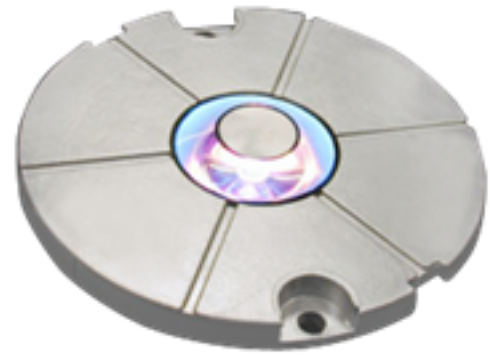

### Compliance

ICAO: Annex 14 Volume I (Current Edition)

FAA: L-852T AC150/5345-46D and Engineering Brief 67

NATO: STANAG 3316

IEC: 61827

STAC

### Uses

The SafeLED TE-I and SafeLED SG-I are omnidirectional LED inset light fixtures. The light is available in two versions either to be connected in a series circuit or a parallel system.

The LED light follows the same light intensity curve as a corresponding halogen lamp with different intensity levels at the CCR.

- Taxiway Edge
- Aircraft Stand Maneuvering Guidance

### Features & Benefits

- Taxiway Edge and Stand Guidance inset LED lights
- 10 mm elevation point, only
- No negative slope (dirt advert design)
- Over voltage surge and lightning protection
- All-in-one integrated and molded electronics with a connector
- An easily replaced prism
- Backwards compatible with halogen lamps on CCR series circuit
- Photometrics and colors in compliance with recommendations in ICAO Annex 14 Volume 1, FAA AC150/5345-46D and FAA EB67D
- Can be powered by an isolating transformer on a standard 6.6 A AGL primary loop, due to the internal converter in the fitting (6.6A version only)
- LED life depends on operation
- All external parts are made of anodized aluminum alloy casting
- All fixings and fastenings are stainless steel
- The fitting has a maximum outer diameter of 203 mm (8") and its projection shall not exceed 10 mm (<1/2") omnidirectional
- The weight of the fitting is less than 3.0 kg

- The fitting is installed directly on an 8" shallow base minimum 100 mm (6.6A version only), or in a Thorn AFL adapter ring on a FAA L-868B deep base
- The fitting is designed to allow easy maintenance
- Only available as a non-monitoring version

### LED Source

The LED technology offers a long lasting light source, low power consumption depending on operation, a technology which is environmentally friendly and robust to vibration. By using SafeLED, the maintenance cost of light fittings and airport operation interruptions, is dramatically reduced.

LED technology secures a future proof Airfield Lighting (AFL) investment and removes the uncertainty of the proposed international phase out regulations for the traditional incandescent lamps.

### Compact Design

The fitting has a low projection height of 10 mm (<1/2") omnidirectional, without any negative slope in front of the prism. This gives the same performance in dry and rainy conditions. The 6.6A version is designed to fit into shallow 100 mm bases. The VAC version is designed to fit into the deeper 134 mm bases.

### Robustness

SafeLED is designed for use in harsh environments. The electronic components are encapsulated in waterproof polyurethane, well protected from wear and tear. Castings are anodized and fixings are stainless steel. Component life cycle is dramatically extended and its operational lifespan is greatly increased. There is also an inbuilt over-voltage surge and lightning protection.

### Mixed Circuit Compatibility

Compatible with incandescent halogen lights on CCR circuits (6.6A). The LED fitting follows the same light intensity curve as a halogen lamp. This allows mixed circuits with halogen and LED fittings. There is no need for updating previously installed AFL infrastructure when installing SafeLED.

### CCR Compatibility

The SafeLED reacts as a halogen lamp with a resistive load profile. When turning on a Constant Current Regulator (CCR), the CCR does not trip as the current does not fluctuate with SafeLED technology.

# TAXIWAY LIGHTING

## SL-TE-I, SL-SG-I

### Operating Conditions

Operating temperature: -55 °C to +80 °C / -55 °F to +176 °F  
 Storage temperature: -55 °C to +80 °C / -55 °F to +176 °F  
 Operating humidity: Up to 100%

### Technical Data

Characteristic	Symbol	Min	Max	Unit
Circuits				
Supply current from parallel VAC circuit (90-260VAC, 50-60Hz)	I <sub>SUPPLY</sub>	2.5	7.1 <sup>1</sup> 8.2 <sup>2</sup>	A <sub>RMS</sub>
Power consumption				
Total power consumption omnidirectional fitting @ 6.6 A <sub>RMS</sub> <b>Note:</b> Power Factor (PF) type 1.0.	P <sub>fit</sub>	1.36	6.78	W
Total power consumption omnidirectional fitting @ 90-260VAC, 50-60Hz. <b>Note:</b> Power Factor (PF) type 0.45.	P <sub>fit</sub>	3.94 W / 8.7 VA		

#### Notes

<sup>1</sup> In accordance with FAA advisory circular 150/5345-47D (Isolation transformers for airport lighting systems).

<sup>2</sup> For max 1s, in accordance with FAA advisory circular 150/5345-10E (Specification for CCRs and regulator monitors).

Power Supply	Integrated, encapsulated electronic converter (6.6A/VAC version). Two-pole FAA plug for connection to the transformer (6.6A version). Three pole Amphenol S44 plug for connection to a VAC parallel circuit.
Optics	Equipped with 1 LED <sup>1</sup> . No color filters required, colors obtained directly by the LED in compliance with standards.
Finish	External parts made of anodized aluminum alloy casting. All fixings and fastenings in stainless steel.
Dimensions	Projection: 10 mm (<1/2"); omnidirectional. Diameter: 203 mm (8").
Net Weight	3.0 kg
Packaging	Volume: 0.006 m <sup>3</sup> . Dimensions: 235 x 255 x 100 mm (6.6A), 220 x 220 x 130 mm (VAC).

#### Notes

<sup>1</sup> Lifetime LED depending on operation.

### Ordering Code

The table below is a guide to order codes for an inset light fitting with X representing the available component parts.

It is important to consider the correct isolation transformer for fittings depending on the configuration.

Component / Ordering Code	X	X	X	X	X	X	X
SafeLED	SL-						
<b>Location</b>							
Taxiway Edge		TE					
Aircraft Stand Maneuvering Guidance		SG					
<b>Fitting</b>							
Inset			I				
<b>Type</b>							
Omni-directional				O			
<b>Color(s)</b>							
Blue					B		
Yellow					Y		
<b>Connection to isolating transformer(s)</b>							
1 Connector						1C	
<b>System</b>							
6.6A <sup>1</sup>							6.6A
VAC							VAC
<b>Additional</b> Shallow base and adapter ring. Isolation transformer, depending on the configuration. For more information, contact ADB SAFEGATE or see <a href="http://www.adbsafegate.com">www.adbsafegate.com</a> . <sup>1</sup> Non-monitored							

### Installation

The fitting can be installed in standard bases or with adapter rings in an existing/new airfield lighting system.

The fitting can have different dimensions as described below.

#### SafeLED TE-I-6.6

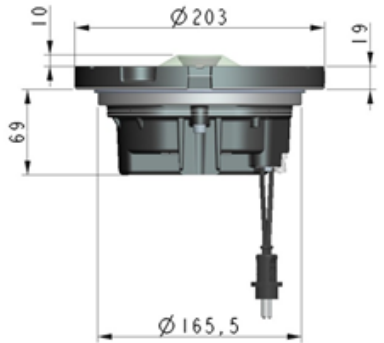

SafeLED TE-I-6.6 side view

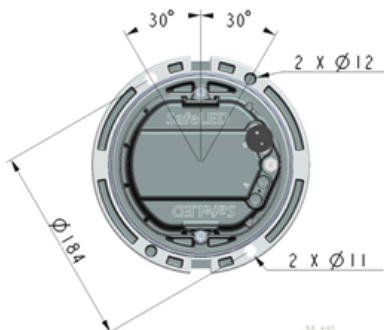

SafeLED TE-I-6.6 top view

The SafeLED-TE-I-6.6 fitting is installed in one of the following:

- Thorn 8 inch shallow base, minimum height 100 mm with side or bottom entry for the cable
- 12" base with side or bottom entry

**Note:** Install with a Thorn AFL adapter ring 12" – 8" with 2×M10 studs (order code 96217254).

- FAA L-868B deep base using an adapter ring

#### SafeLED TE-I-230V

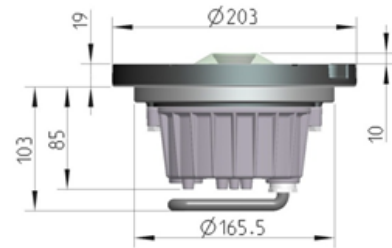

SafeLED TE-I-230V side view

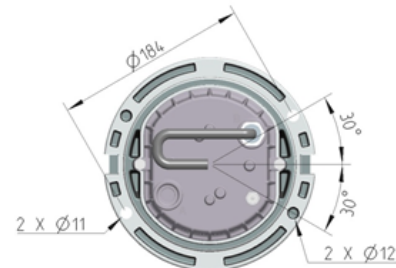

SafeLED TE-I-230V top view

The SafeLED-TE-I-230V fitting is installed in one of the following:

- Thorn 8 inch shallow base minimum height 134 mm with side or bottom entry for the cable
- 12" base with side or bottom entry

**Note:** Install with a Thorn AFL adapter ring 12" – 8", 2×M10 studs (order code 96217254).

- FAA L-868B deep base using an adapter ring

# TAXIWAY LIGHTING

## SL-TE-I, SL-SG-I

### Photometric Data

This section shows the typical optical performance of the Taxiway Edge blue light according to the ICAO and FAA L-852T standards and the photometric of the yellow Aircraft stand maneuvering guidance light, which is defined in ICAO Annex 14, paragraph 5.3.25.3.

#### Photometry

Luminous intensity versus vertical angles. The light was measured every 30° azimuthally.

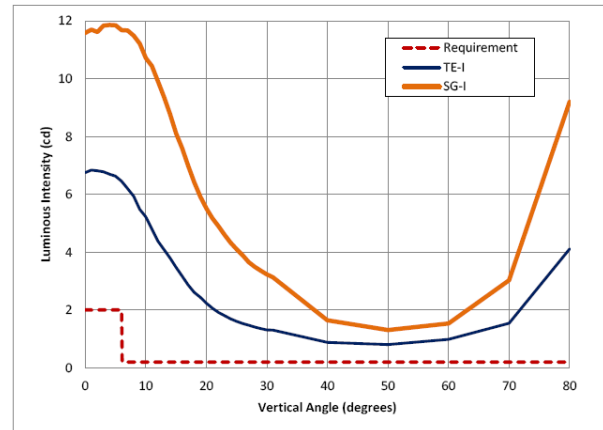

#### Chromaticity

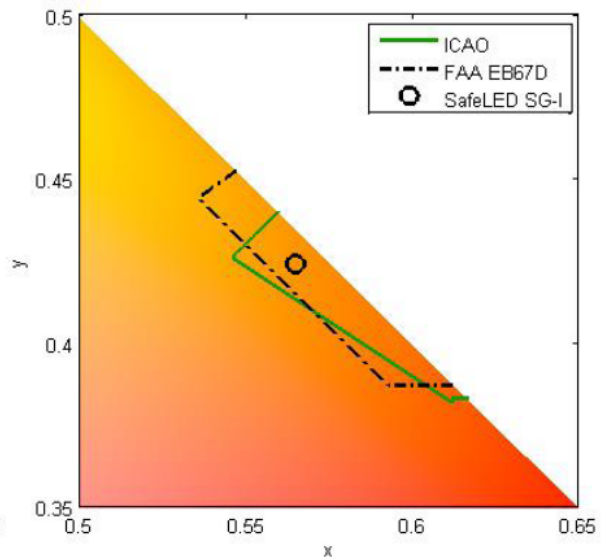
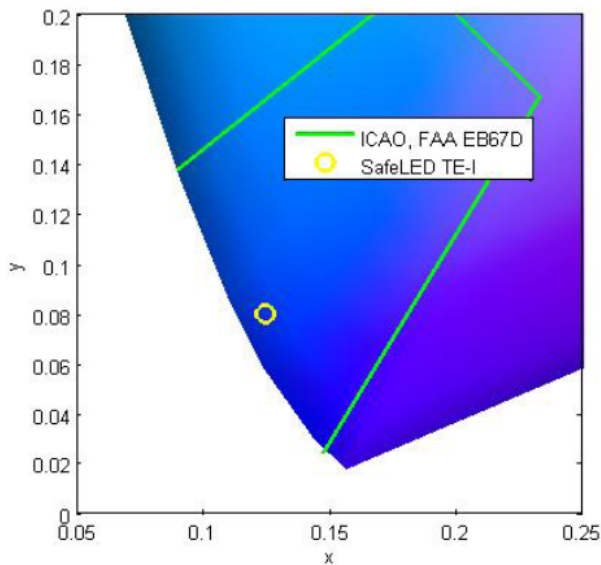

**Note:** All descriptions and photometric characteristics in this publication present only general particulars and shall not form part of any contract. The right is reserved to change them without prior notification. For more information, contact ADB SAFEGATE for compliance with other standards.

[www.adbsafegate.com](http://www.adbsafegate.com)

Product specifications may be subject to change, and specifications listed here are not binding. Confirm current specifications at time of order.