

Airfield Lighting

Product Description

Accessories

- IDM 6508 Transformer case
- IDM 6473 Transformer case
- IDM 6524 Extension ring
- Adapter ring 12"-8"
- IDM 6509 Cover plate
- IDM 5839 Curve tube
- IDM 5448 Transformer case
- IDM 6521 Base plate for signs
- IDM 6522 Frangible coupling signs
- IDM 5838 Base plate
- IDM 5840 Frangible coupling



Note: *This page is blank for convenient double-sided printing.*

PRODUCT DESCRIPTION
AIRFIELD LIGHTING ACCESSORIES
CONTENTS

Section	Description	Page No.
1.	IDM 6508 TRANSFORMER CASE (L-868)	2
2.	IDM 6473 TRANSFORMER CASE (L-868)	2
3.	IDM 6524 EXTENSION RING	3
4.	ADAPTER RING 12"-8" ERROR! BOOKMARK NOT DEFINED.	
5.	IDM 6509 COVER PLATE.....	4
6.	IDM 5839 CURVE TUBE.....	4
7.	IDM 5448 TRANSFORMER CASE (L-867)	5
8.	IDM 6521 BASE PLATE FOR SIGNS.....	5
9.	IDM 6522 FRANGIBLE COUPLING FOR SIGNS	6
10.	IDM 5838 BASE PLATE	6
11.	IDM 5840 FRANGIBLE COUPLING	7
12.	IDM 6522 FRANGIBLE COUPLING FOR FITTINGS.....	7

1. IDM 6508 TRANSFORMER CASE (L-868)

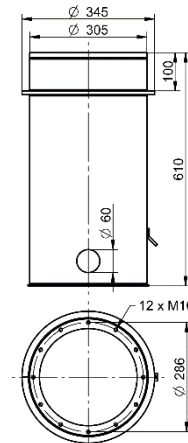

- For applications subject to aircraft and other heavy vehicular loading.
- L-868 size B.
- Welded steel construction.
- Hot-dip galvanized.
- Different conduit connection or grommet sizes available on request.
- Weight 20.5 kg.

2. IDM 6473 TRANSFORMER CASE (L-868)

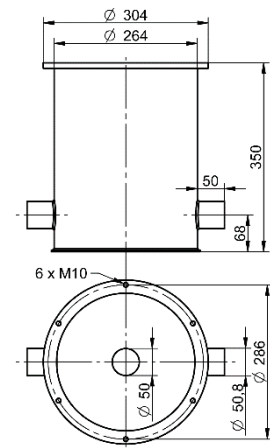

- For applications subject to aircraft and other heavy vehicular loading.
- For 12" luminaires, 8" luminaires with adapter ring IDM 6479.
- Welded steel construction.
- Hot-dip galvanized.
- Weight 10.4 kg.

3. IDM 6524 EXTENSION RING

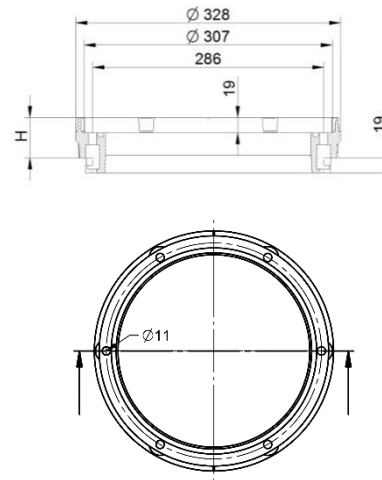

- Extension ring for 12" base receptacles with 19 mm flange.
- Fixing with six (6) DIN 7894 A4 M10x20/25 bolts, included.
- Luminaire attached with normal M10x25 bolts.
- Available nominal heights: 30, 40, 50 and 60 mm (attached with M10x20 bolts).
- Available also as package with 5 mm spacer ring, total nominal heights: 35, 45, 55 and 65 mm (attached with M10x25 bolts).
- 2, 3 and 4 mm spacer rings available for small adjustment. Adjusted height = nominal height + max. 5 mm adjustment.

4. ADAPTER RING 12"-8"

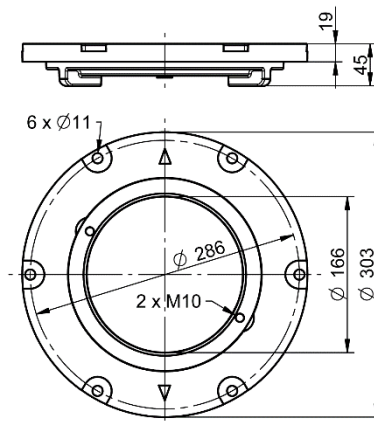
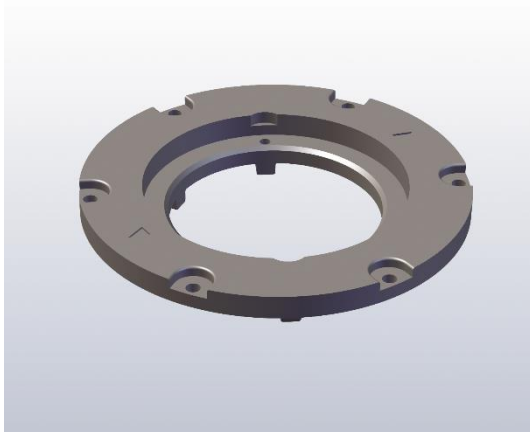

- Adapter ring to install 8" luminaire into a 12" base
- 19 mm flange height.
- Anodised aluminium.
- Weight 2.6 kg.

The adapter ring is delivered without accessories such as gasket, bolts, locking washers or nuts

Available with below versions
 T: Insert thread version (locking features)
 S: Stud bolt version (available only with metric threads)
 M: Metric threads (M10)
 U: UNC threads (UNC 3/8")

Example designation:
 Adapter ring 12"-8"-T-M

5. IDM 6509 COVER PLATE

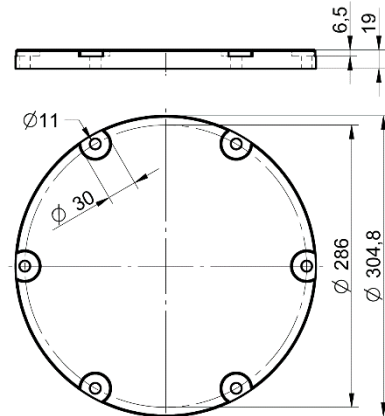

- Steel or aluminium cover plate for L-868 size B transformer cases.
- Hot-dip galvanized.
- Weight 10.5 kg.
- Different sizes available, also for base receptacles.
- Alternatively available with L-867 bolt pattern also with internal thread ISO 228/1-G2 connection for frangible coupling.

6. IDM 5839 CURVE TUBE

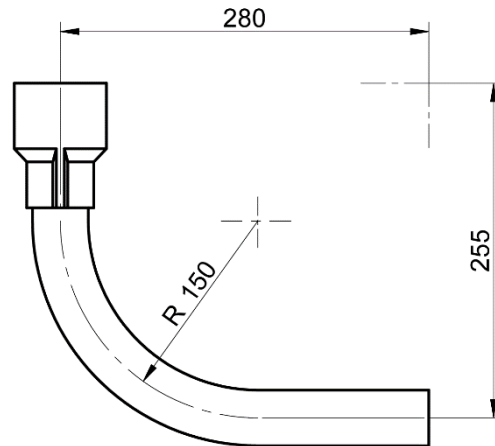
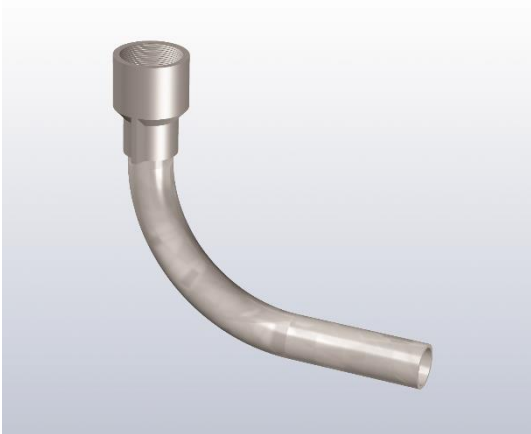

- Tube hot galvanized steel.
- Adapter cast aluminium alloy.
- Weight 1.5 kg.
- Thread ISO 228/1-G 2 for connection to frangible coupling.

7. IDM 5448 TRANSFORMER CASE (L-867)

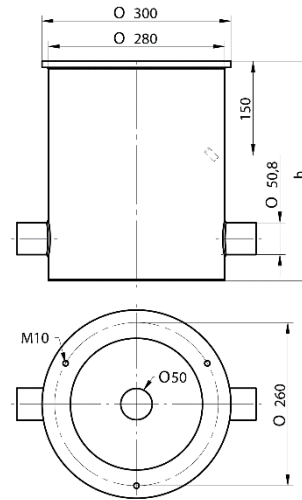

- For applications subject to occasional light vehicular loading but not aircraft or other heavy vehicular loading.
- L-867 size B bolt pattern.
- Welded steel construction.
- Hot-dip galvanized.
- Available heights:
 - 350 mm (conduit connection 50mm)
 - 500 mm (conduit connection 90mm)
- Weight:
 - 8.5 kg (35mm)
 - 10.0 kg (500 mm)

8. IDM 6521 BASE PLATE FOR SIGNS

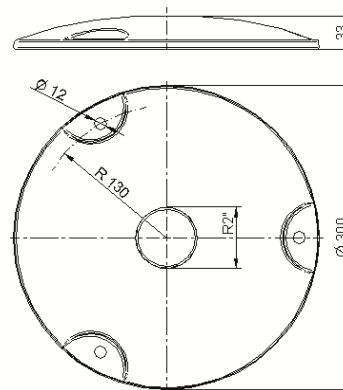

- Aluminium base plate for guidance signs.
- Anodised.
- Weight 2.6 kg.
- Internal thread ISO 228/1-G2 to take frangible coupling IDM 6522.

9. IDM 6522 FRANGIBLE COUPLING FOR SIGNS

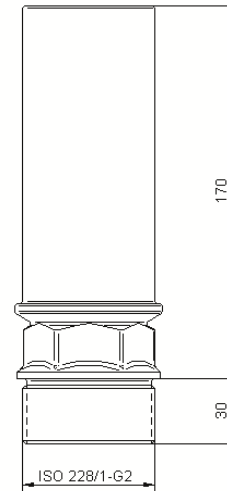
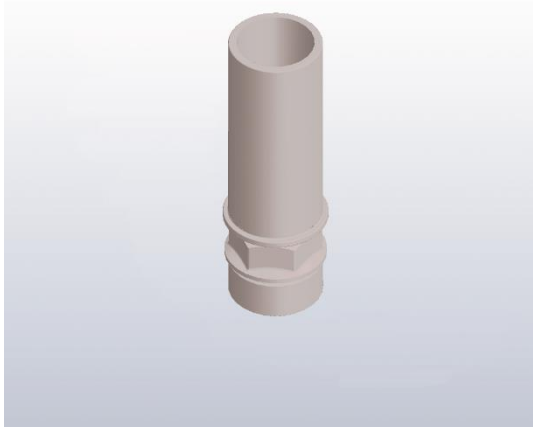

- Outside diameter (top) 60 mm
- Cast aluminium alloy.
- Chromatised.
- Key opening 52 mm
- To be used with base plate 6521
- Thread ISO 228/1-G 2 A

10. IDM 5838 BASE PLATE

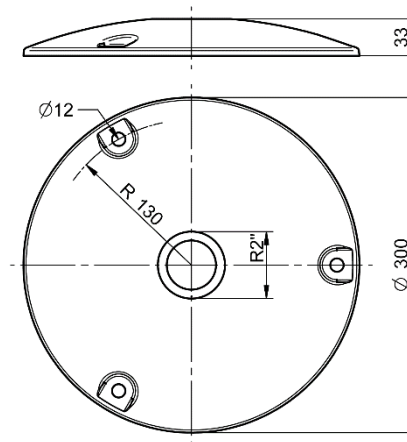

- Aluminium base plate for L-867 size B transformer cases.
- Chromatised and powder coated aviation yellow.
- Weight 1.5 kg
- Internal thread ISO 228/1-G2 to take frangible coupling IDM 5840.
- Also available without thread as IDM 5841 case plate.

11. IDM 5840 FRANGIBLE COUPLING

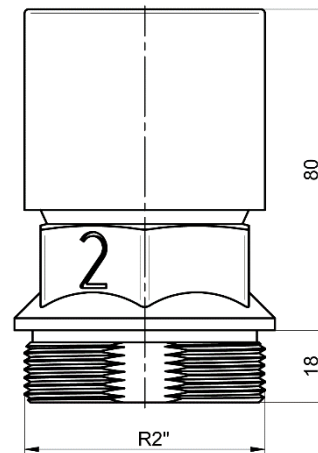

- Outside diameter (top) 60 mm
- Cast aluminium alloy.
- Chromatised and powder coated aviation yellow.
- Key opening 52 mm.
- Available two classes (2,4).
- Thread ISO 228/1-G 2 A.

12. IDM 6522 FRANGIBLE COUPLING FOR FITTINGS



- Outside diameter (top) 60 mm
- Cast aluminium alloy.
- Chromatised
- Key opening 52 mm
- To be used with base plate 5838
- Thread ISO 228/1-G 2 A
- Thread length 18mm
- Available two classes (2,4).

Check in to the future

How many aircraft can your airport handle today? Can this number be increased without adverse effects on the airport's safety level? It is a known fact that traffic volume will rise in the foreseeable future. More movements will demand monitoring of the entire airport. Requirements will be sharpened and the development of an integrated system

controlling not only ground movements but also air traffic close to the airport is of the highest interest. The International Civil Aviation Organization (ICAO) already describes A-SMGCS, Advanced Surface Movement Guidance and Control System, as the answer to the future modern airport need to control the entire airport space in one superior system.

To a larger extent than today's systems, A-SMGCS will rely on automated processes to give both pilots and traffic controllers exact information about positions and directions. Safegate Group delivers complete A-SMGCS solutions already, as well as all vital parts relating to it. Safegate Group can check your airport into the future – today!



Safegate Group HQ
Djurhagegatan 19
SE-213 76 Malmö, Sweden
Phone: +46 (0)40 699 17 00
Fax: +46 (0)40 699 17 30
E-mail: market@safegate.com

Australia
australia@safegate.com
+61 (0)3 9720-3233

Austria
office@avibit.com
+43 316 429961

Brazil
brazil@safegate.com
+55 11 2137 4405

China
china@safegate.com
+8610-85275297

Dubai
dubai@safegate.com
+971 4 452 75 75

Finland
finland@safegate.com
+358 (0)20754 7700

France
france@safegate.com
+33 (0)1 42 99 60 40

Germany
germany@safegate.com
+49 (0)4121 464 303

India
india@safegate.com
+91 11 4106 1545

Malaysia
malaysia@safegate.com
+60 32 011 3522

Qatar
qatar@safegate.com
+974 436 9628

Russia
russia@safegate.com
+7 495 917 4614

Singapore
singapore@safegate.com
+65 6289 6893

Spain
spain@safegate.com
+34 917 157 598

UK
uk@safegate.com
+44 (0)208 573 0384

USA
usa@safegate.com
+1 763 535 92 99

SAFEGATE
GROUP 

Safegate Group offers solutions for increased safety, efficiency and environmental benefits to airports worldwide. The company was founded in 1973 and has its headquarters in Malmö, Sweden. Safegate Group has more than 70 partners around the globe in order to be close to its customers. Earlier members of Safegate Group include Thorn AFL and Idman, who both have over 40 years of experience in airfield lighting solutions for airports and heliports. The latest member of Safegate Group is Avibit, a leading provider of next generation software applications and integration of efficient air traffic control systems. Safegate Group's complete range of products and services, a "one-stop shop", provides solutions to customers and airborne travellers around the globe.

www.safegate.com