



Series Cutout (SCO)

User Manual

96A0294, Rev. J, 2020/06/26



A.0 Disclaimer / Standard Warranty

CE certification

The equipment listed as CE certified means that the product complies with the essential requirements concerning safety and hygiene. The European directives that have been taken into consideration in the design are available on written request to ADB SAFEGATE.

ETL certification

The equipment listed as ETL certified means that the product complies with the essential requirements concerning safety and FAA Airfield regulations. The FAA directives that have been taken into consideration in the design are available on written request to ADB SAFEGATE.

All Products Guarantee

ADB SAFEGATE will correct by repair or replacement per the applicable guarantee above, at its option, equipment or parts which fail because of mechanical, electrical or physical defects, provided that the goods have been properly handled and stored prior to installation, properly installed and properly operated after installation, and provided further that Buyer gives ADB SAFEGATE written notice of such defects after delivery of the goods to Buyer. Refer to the Safety section for more information on Material Handling Precautions and Storage precautions that must be followed.

ADB SAFEGATE reserves the right to examine goods upon which a claim is made. Said goods must be presented in the same condition as when the defect therein was discovered. ADB SAFEGATE further reserves the right to require the return of such goods to establish any claim.

ADB SAFEGATE's obligation under this guarantee is limited to making repair or replacement within a reasonable time after receipt of such written notice and does not include any other costs such as the cost of removal of defective part, installation of repaired product, labor or consequential damages of any kind, the exclusive remedy being to require such new parts to be furnished.

ADB SAFEGATE's liability under no circumstances will exceed the contract price of goods claimed to be defective. Any returns under this guarantee are to be on a transportation charges prepaid basis. For products not manufactured by, but sold by ADB SAFEGATE, warranty is limited to that extended by the original manufacturer. This is ADB SAFEGATE's sole guarantee and warranty with respect to the goods; there are no express warranties or warranties of fitness for any particular purpose or any implied warranties of fitness for any particular purpose or any implied warranties other than those made expressly herein. All such warranties being expressly disclaimed.

Standard Products Guarantee

Products of ADB SAFEGATE manufacture are guaranteed against mechanical, electrical, and physical defects (excluding lamps) which may occur during proper and normal use for a period of two years from the date of ex-works delivery, and are guaranteed to be merchantable and fit for the ordinary purposes for which such products are made.



Note

See your sales order contract for a complete warranty description.

FAA Certified product installed in the United States and purchased or funded with monies through the Airport Improvement Program (AIP) installations guarantee

ADB SAFEGATE L858 Airfield Guidance Signs are warranted against mechanical and physical defects in design or manufacture for a period of 2 years from date of installation, per FAA AC 150/5345-44 (applicable edition).

ADB SAFEGATE L858(L) Airfield Guidance Signs are warranted against electrical defects in design or manufacture of the LED or LED specific circuitry for a period of 4 years from date of installation, per FAA EB67 (applicable edition).

ADB SAFEGATE LED light fixtures (with the exception of obstruction lighting) are warranted against electrical defects in design or manufacture of the LED or LED specific circuitry for a period of 4 years from date of installation, per FAA EB67 (applicable edition).



Note

See your sales order contract for a complete warranty description.

Liability



WARNING

Use of the equipment in ways other than described in the catalog leaflet and the manual may result in personal injury, death, or property and equipment damage. Use this equipment only as described in the manual.

ADB SAFEGATE cannot be held responsible for injuries or damages resulting from non-standard, unintended uses of its equipment. The equipment is designed and intended only for the purpose described in the manual. Uses not described in the manual are considered unintended uses and may result in serious personal injury, death or property damage.

Unintended uses, includes the following actions:

- Making changes to equipment that have not been recommended or described in this manual or using parts that are not genuine ADB SAFEGATE replacement parts or accessories.
- Failing to make sure that auxiliary equipment complies with approval agency requirements, local codes, and all applicable safety standards if not in contradiction with the general rules.
- Using materials or auxiliary equipment that are inappropriate or incompatible with your ADB SAFEGATE equipment.
- Allowing unskilled personnel to perform any task on or with the equipment.

© ADB SAFEGATE BV

This manual or parts thereof may not be reproduced, stored in a retrieval system, or transmitted, in any form or by any means, electronic, mechanical, photocopying, recording, nor otherwise, without ADB SAFEGATE BV's prior written consent.

This manual could contain technical inaccuracies or typographical errors. ADB SAFEGATE BV reserves the right to revise this manual from time to time in the contents thereof without obligation of ADB SAFEGATE BV to notify any person of such revision or change. Details and values given in this manual are average values and have been compiled with care. They are not binding, however, and ADB SAFEGATE BV disclaims any liability for damages or detriments suffered as a result of reliance on the information given herein or the use of products, processes or equipment to which this manual refers. No warranty is made that the use of the information or of the products, processes or equipment to which this manual refers will not infringe any third party's patents or rights. The information given does not release the buyer from making their own experiments and tests.

TABLE OF CONTENTS

1.0 Safety	1
1.1 Safety Messages	1
1.1.1 Introduction to Safety	2
1.1.2 Intended Use	2
1.1.3 Material Handling Precautions: Storage	3
1.1.4 Material Handling Precautions: Fasteners	3
1.1.5 Maintenance Safety	4
1.1.6 Material Handling Precautions, ESD	4
1.1.7 Arc Flash and Electric Shock Hazard	5
2.0 Introduction	7
2.1 About this manual	7
2.1.1 How to work with the manual	7
2.2 SCO Introduction	7
2.2.1 SCO Cutout: Required Equipment	10
3.0 Specifications	11
4.0 Installation	13
4.1 Introduction	13
4.2 Unpacking	13
4.3 Individual Cutout Installation	13
4.3.1 Individual Cutout Mounting	13
4.3.2 Mounting Individual Cutouts on Plate	16
4.3.3 Mounting Individual Cutout in NEMA Enclosure (Sold Separately)	17
4.3.4 Mounting Multiple SCO Cutouts Side-By-Side	19
4.4 Individual Cutout Wiring	19
4.4.1 Pre-Installed Cutout Installation	22
5.0 SCO Operation	25
6.0 Maintenance	27
6.1 Introduction	27
6.1.1 Megging Circuit	27
6.2 Grounding Cover	27
A.0 SUPPORT	29
A.1 ADB SAFEGATE Website	29
A.2 Recycling	30
A.2.1 Local Authority Recycling	30
A.2.2 ADB SAFEGATE Recycling	30

1.0 Safety

Introduction to Safety

This section contains general safety instructions for installing and using ADB SAFEGATE equipment. Some safety instructions may not apply to the equipment in this manual. Task- and equipment-specific warnings are included in other sections of this manual where appropriate.

1.1 Safety Messages

HAZARD Icons used in the manual

For all HAZARD symbols in use, see the Safety section. All symbols must comply with ISO and ANSI standards.

Carefully read and observe all safety instructions in this manual, which alert you to safety hazards and conditions that may result in personal injury, death or property and equipment damage and are accompanied by the symbol shown below.



WARNING

Failure to observe a warning may result in personal injury, death or equipment damage.



DANGER - Risk of electrical shock or ARC FLASH

Disconnect equipment from line voltage. Failure to observe this warning may result in personal injury, death, or equipment damage. ARC Flash may cause blindness, severe burns or death.



WARNING - Wear personal protective equipment

Failure to observe may result in serious injury.



WARNING - Do not touch

Failure to observe this warning may result in personal injury, death, or equipment damage.



CAUTION

Failure to observe a caution may result in equipment damage.

Qualified Personnel



Important Information

The term **qualified personnel** is defined here as individuals who thoroughly understand the equipment and its safe operation, maintenance and repair. Qualified personnel are physically capable of performing the required tasks, familiar with all relevant safety rules and regulations and have been trained to safely install, operate, maintain and repair the equipment. It is the responsibility of the company operating this equipment to ensure that its personnel meet these requirements.

Always use required personal protective equipment (PPE) and follow safe electrical work practice.

1.1.1 Introduction to Safety



CAUTION

Unsafe Equipment Use

This equipment may contain electrostatic devices, hazardous voltages and sharp edges on components

- Read installation instructions in their entirety before starting installation.
- Become familiar with the general safety instructions in this section of the manual before installing, operating, maintaining or repairing this equipment.
- Read and carefully follow the instructions throughout this manual for performing specific tasks and working with specific equipment.
- Make this manual available to personnel installing, operating, maintaining or repairing this equipment.
- Follow all applicable safety procedures required by your company, industry standards and government or other regulatory agencies.
- Install all electrical connections to local code.
- Use only electrical wire of sufficient gauge and insulation to handle the rated current demand. All wiring must meet local codes.
- Route electrical wiring along a protected path. Make sure they will not be damaged by moving equipment.
- Protect components from damage, wear, and harsh environment conditions.
- Allow ample room for maintenance, panel accessibility, and cover removal.
- Protect equipment with safety devices as specified by applicable safety regulations
- If safety devices must be removed for installation, install them immediately after the work is completed and check them for proper functioning prior to returning power to the circuit.

Failure to follow this instruction can result in serious injury or equipment damage

Additional Reference Materials



Important Information

- IEC - International Standards and Conformity Assessment for all electrical, electronic and related technologies.
- IEC 60364 - Electrical Installations in Buildings.
- FAA Advisory: AC 150/5340-26 (current edition), Maintenance of Airport Visual Aid Facilities.
- Maintenance personnel must refer to the maintenance procedure described in the ICAO Airport Services Manual, Part 9.
- ANSI/NFPA 79, Electrical Standards for Metalworking Machine Tools.
- National and local electrical codes and standards.

1.1.2 Intended Use



CAUTION

Use this equipment as intended by the manufacturer

This equipment is designed to perform a specific function, do not use this equipment for other purposes

- Using this equipment in ways other than described in this manual may result in personal injury, death or property and equipment damage. Use this equipment only as described in this manual.

Failure to follow this instruction can result in serious injury or equipment damage

1.1.3 Material Handling Precautions: Storage



CAUTION

Improper Storage

Store this equipment properly

- If equipment is to be stored prior to installation, it must be protected from the weather and kept free of condensation and dust.

Failure to follow this instruction can result in equipment damage

1.1.4 Material Handling Precautions: Fasteners



DANGER

Foreign Object Damage - FOD

This equipment may contain fasteners that may come loose - torque properly.

- Only use fasteners of the same type as the one originally supplied with the equipment.
- Use of incorrect combination of gaskets, bolts and nuts can create severe damages to the product installation and create safety risk .
- You need to know what base the light fixture will be installed in, in order to chose the correct gasket, bolts and nuts.
- Bolt type, length, and torque value are determined by type of base, height of spacers used, and clamp force required in FAA Engineering Brief No 83 (latest revision).
- Due to the risk of bolts vibrating loose, do not use any type of washer with the fixing bolts (such as split lock washers) other than an anti-vibration washer. Anti-vibration washers as defined in FAA EB 83 (latest edition) must be used. For installations other than FAA, use the base can manufacturer's recommendations.
- Always tighten the fasteners to the recommended torque. Use a calibrated torque wrench and apply the recommended adhesive type.
- Obey the instructions of the adhesives necessary for the fasteners.

Failure to follow these warnings may cause the fasteners to loosen, damage the equipment, potentially to loosen the equipment. This can lead to a highly dangerous situation of FOD, with potential lethal consequences.



Note

To minimize the risk of errors, the ADB SAFEGATE Sales Representative will have information on which gasket goes with which base. This information is also provided in the product Data sheets, the User Manuals and the Spare Part Lists.



CAUTION

Use of incorrect combination of gaskets, bolts and nuts can create severe damages to the product installation and create multiple safety risks.

To obtain a safe and watertight installation the O-ring and retaining bolt stated in the document must be used.

You need to know what base the light fixture will be installed in, in order to choose the correct gasket, bolts and nuts.

Failure to follow these cautions can result in equipment damage or aircraft FOD.

1.1.5 Maintenance Safety



DANGER

Electric Shock Hazard

This equipment may contain electrostatic devices

- Do not operate a system that contains malfunctioning components. If a component malfunctions, turn the system OFF immediately.
- Disconnect and lock out electrical power.
- Allow only qualified personnel to make repairs. Repair or replace the malfunctioning component according to instructions provided in its manual.

Failure to follow these instructions can result in death or equipment damage

1.1.6 Material Handling Precautions, ESD



CAUTION

Electrostatic Sensitive Devices

This equipment may contain electrostatic devices

- Protect from electrostatic discharge.
- Electronic modules and components should be touched only when this is unavoidable e.g. soldering, replacement.
- Before touching any component of the cabinet you shall bring your body to the same potential as the cabinet by touching a conductive earthed part of the cabinet.
- Electronic modules or components must not be brought in contact with highly insulating materials such as plastic sheets, synthetic fiber clothing. They must be laid down on conductive surfaces.
- The tip of the soldering iron must be grounded.
- Electronic modules and components must be stored and transported in conductive packing.

Failure to follow this instruction can result in equipment damage

1.1.7 Arc Flash and Electric Shock Hazard



DANGER

Series Circuits have Hazardous Voltages

This equipment produces high voltages to maintain the specified current - Do NOT Disconnect while energized.

- Allow only qualified personnel to perform maintenance, troubleshooting, and repair tasks.
- Only persons who are properly trained and familiar with ADB SAFEGATE equipment are permitted to service this equipment.
- An open airfield current circuit is capable of generating >5000 Vac and may appear OFF to a meter.
- Never unplug a device from a constant current circuit while it is operating; Arc flash may result.
- Disconnect and lock out electrical power.
- Always use safety devices when working on this equipment.
- Follow the recommended maintenance procedures in the product manuals.
- Do not service or adjust any equipment unless another person trained in first aid and CPR is present.
- Connect all disconnected equipment ground cables and wires after servicing equipment. Ground all conductive equipment.
- Use only approved ADB SAFEGATE replacement parts. Using unapproved parts or making unapproved modifications to equipment may void agency approvals and create safety hazards.
- Check the interlock systems periodically to ensure their effectiveness.
- Do not attempt to service electrical equipment if standing water is present. Use caution when servicing electrical equipment in a high-humidity environment.
- Use tools with insulated handles when working with airfield electrical equipment.

Failure to follow these instructions can result in death or equipment damage

2.0 Introduction

A series cutout (SCO) isolates the series circuit from the constant current regulator (CCR) during maintenance or testing operations. It allows periodic insulation resistance measurement of the series circuit to ground without disconnecting the series cable. ADB's SCO is patented under U.S. patent number 5952737.

2.1 About this manual

The manual shows the information necessary to:

- Install
- Carry Out Maintenance
- Carry Out Troubleshooting on the SCO.

2.1.1 How to work with the manual

1. Familiarize yourself with the structure and content.
2. Carry out the actions completely and in the given sequence.

2.2 SCO Introduction

Figure 1: SCO Cutout



See [Figure 2](#) for an exploded view of the SCO cutout.

Figure 2: SCO Cutout (Exploded View)

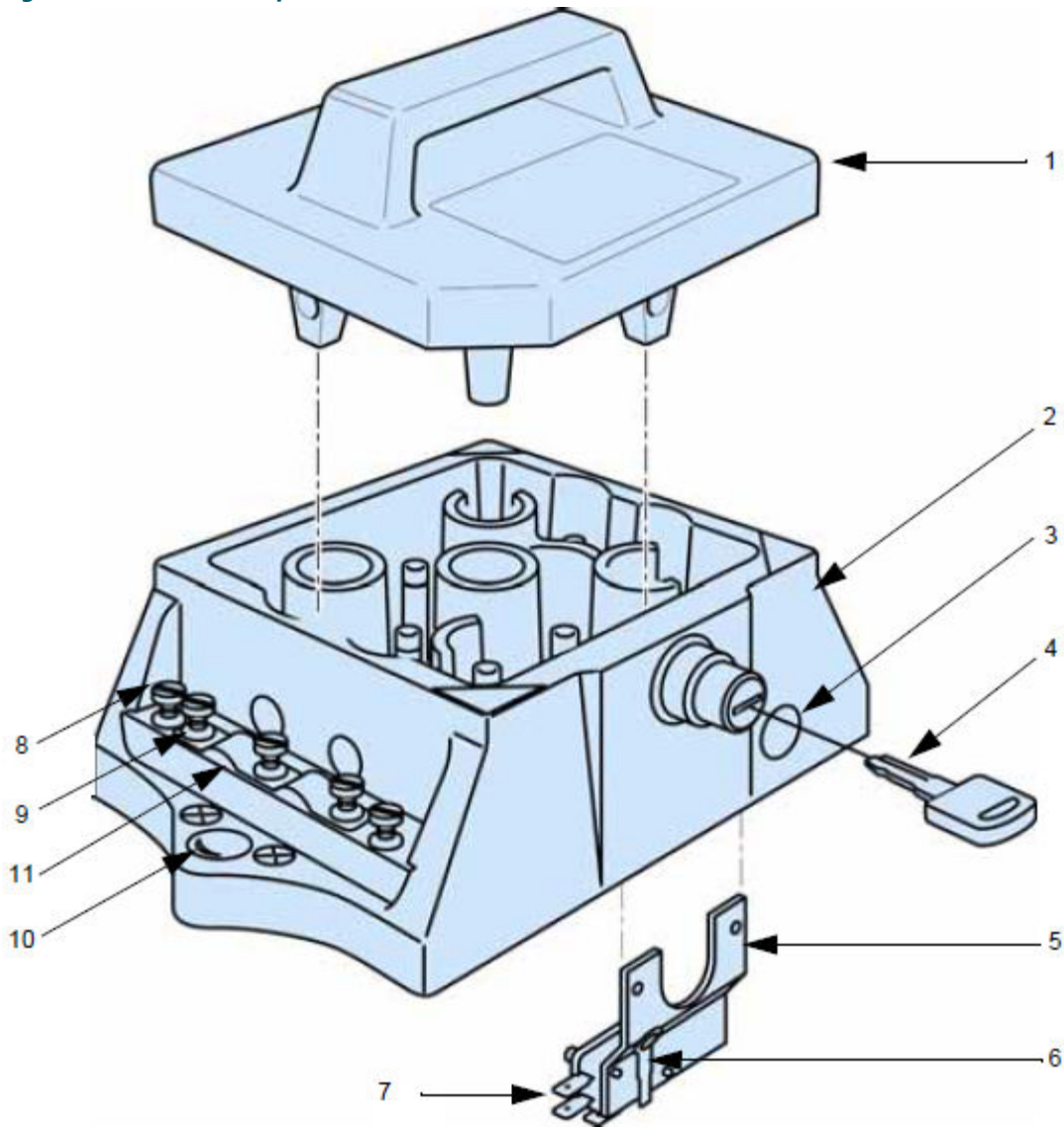

1. Cover
2. Body
3. Insulation Measurement Socket
4. Lock and Key
5. Interlock Switch (Located Inside Cutout)
6. Interlock Switch Wiring Shield Connection (If Used)
7. Interlock Switch Terminals (If Used)
8. Grounding Terminals (2)
9. L-824 Shield Grounding Clamp Screws (3)
10. Body Fastening Hole
11. Airfield Series Cable Stress Relief and Airfield Cable Shield Grounding Clamp

See [Figure 3](#). The handle of the SCO cutout can be rotated to any of three positions to allow different functions. Refer to [Table 1](#) for the three positions of the SCO cutout.

Figure 3: SCO Cutout Positions

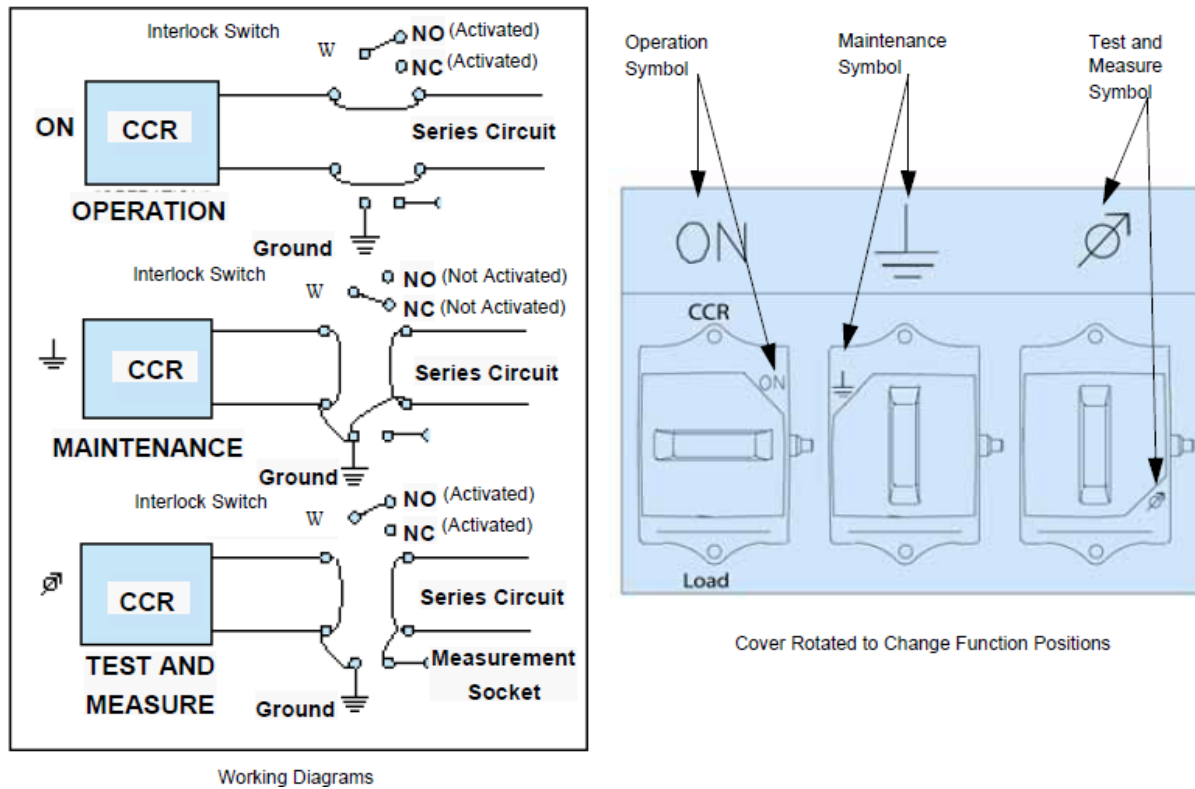

Table 1: SCO Cutout Positions

Position	Description
Operation	The regulator is connected to the series circuit and the interlock switch (if used) is activated.
Maintenance	The regulator and the series circuit are both shorted and grounded and the interlock switch (if used) is not activated.
Test and Measure	The regulator is shorted and grounded; the series circuit is shorted and connected to the measurement socket, and the interlock switch (if used) is activated. In this position, the insulation resistance of the series circuit can be measured. The regulator operation can be tested under short-circuited output conditions.

An activated interlock switch means that a connection exists between the wiper (W) (see Figure 3, Working Diagrams) and the normally open (NO on Figure 3, Working Diagrams) contact. An interlock switch that is not activated means that there is no connection between the wiper (W) and the normally open (NO) (see Figure 3, Working Diagrams) contact. The W and NO contacts are used to interlock the CCR via the CCR’s remote control terminal block.

When the cover is removed, the interlock switch is not activated.

2.2.1 SCO Cutout: Required Equipment

Table 2: Required Equipment Supplied

Description	Quantity
SCO cutout with two keys	1
Instruction manual	1
Handle Position decal	1
Read Manual decal	1

3.0 Specifications

Current Carrying Capacity: Current carrying capacity is 20 amps AC.

Maximum Voltage: Maximum voltage is 5 kV.

Interlock Switch Rating: Interlock switch rating is 2 A, 440 V ac.

Key Lockable: The SCO cutout is key lockable in any position.

Operating Temperature: -55 to +55 °C (-67 to +131 °F)

Weight: The SCO cutout weighs 6 lb (2.7 kg).

Dimensions: See [Figure 4](#) for SCO cutout dimensions.

Figure 4: SCO Cutout Dimensions

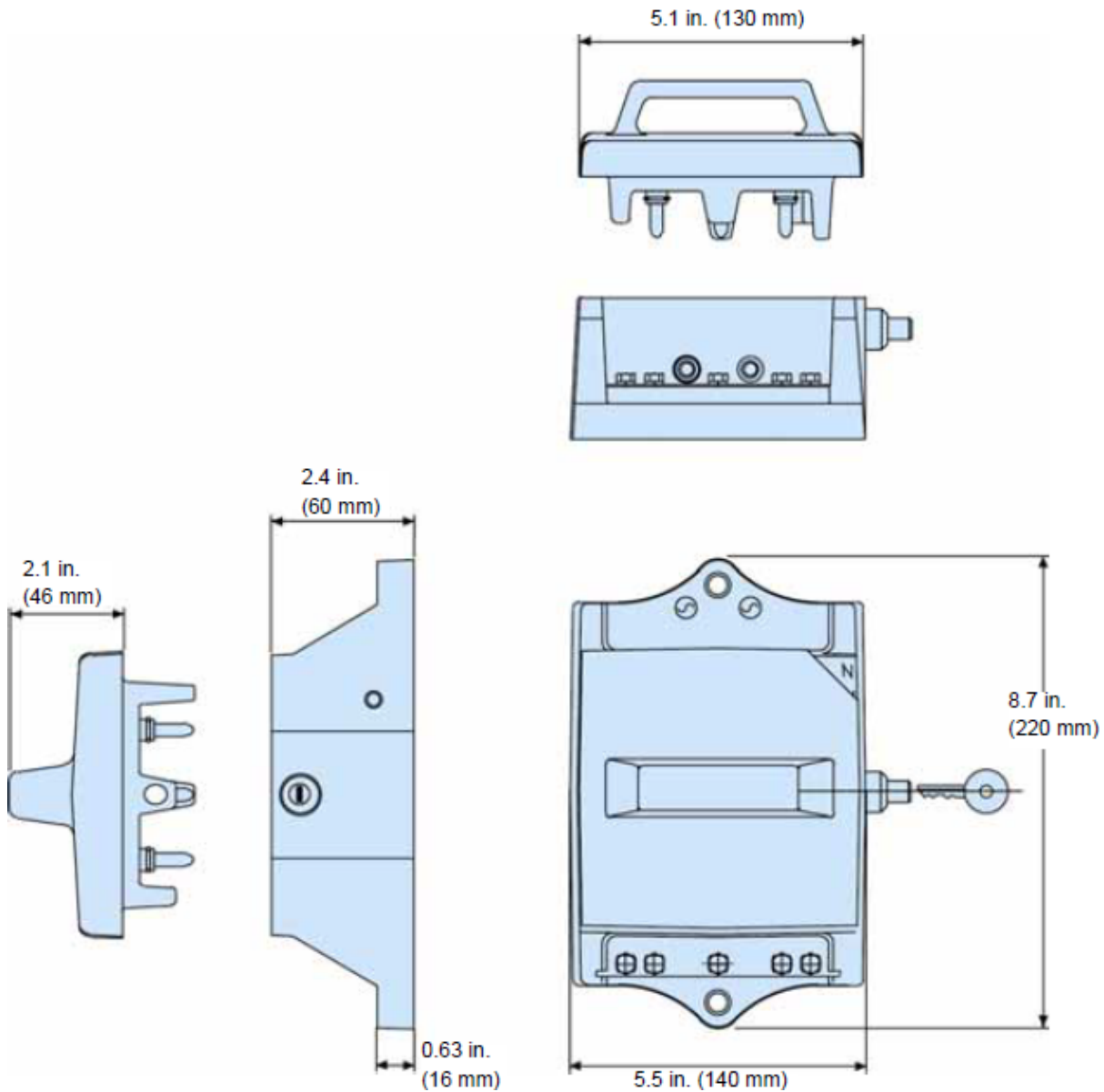

4.0 Installation



WARNING

Allow only qualified personnel to perform the following tasks. Observe and follow the safety instructions in this document and all other related documentation.

4.1 Introduction

This section provides installation instructions for the SCO cutout. It includes equipment unpacking, individual cutout installation, cutout wiring, and pre-installed cutout installation. Wiring instructions for pre-installed cutouts are provided in *Pre-Installed Cutout Installation* in this section.

A cutout can be installed individually on or close to a constant current regulator (CCR). It can also be incorporated inside other equipment. Examples would be in a bay on a SwitchGear regulator system or internal to a ADB Airfield Solutions Signature Series™ CCR. It can also be incorporated inside other equipment.

4.2 Unpacking

The equipment is shipped ready for installation. Handle equipment very carefully to prevent component damage. Unpack the carton upon receipt and check the contents and their condition. Note any exterior damage to the carton that might lead to detection of equipment damage.

If you note any damage to any equipment, file a claim with the carrier immediately. The carrier may need to inspect the equipment.

The carton contains the following:

- SCO cutout
- Two keys
- Handle Position decal
- Read Manual decal
- Instruction Manual

4.3 Individual Cutout Installation

This subsection provides information about installing individual SCO cutouts. It includes individual cutout mounting and wiring. It also includes pre-installed cutout installation.

4.3.1 Individual Cutout Mounting

The series cutout can be installed in the vault substation, in the vicinity of the CCR to which it is connected. For example, the cutout can be mounted in the following ways:

- On the wall or rack (Unistrut® or similar type of channel) beside the CCR
- In a "Field Junction Box" containing a large number of cutouts
- In a separate enclosure beside the CCR

In case L-847 circuit selectors are used, the cutouts may be used on either side (input or output) of the selectors, but preferably on the output side (one cutout for each series circuit). Some installations use a cutout on both the input and outputs of the L-847.



WARNING

- When using the SCO cutout with a circuit selector, the regulator must be turned off and locked out before performing any insulation resistance measurements. To operate the regulator without erratic results, all SCO cutouts must be returned to the normal operating position.
- To test the regulator under short circuit conditions, all SCO cutouts after the circuit selector must be in the test & measurement position.

Before mounting the SCO cutout, determine if the interlock switch will be used. See [Figure 11](#) for application information for interlocking with the CCR. If the interlock is used, determine how the wiring for the CCR remote control terminal block will be routed. The wire can be routed through the mounting plate or through the body of the SCO cutout. Guidance for routing through the mounting plate is shown in [Figure 5](#). [Figure 6](#) provides guidance for routing through the SCO body.



Note

If the interlock switch is wired from behind the panel (in line with the interlock switch), then drill a hole as shown in [Figure 5](#). Be sure to de-bur the hole and place a spiral wrap around the wire leads.

If the interlock switch is wired by cutting the thin wall in the cutout body (see [Figure 6](#), Item 3), then drill the hole in the lower right portion of the plate outside the perimeter of the cutout and use a conventional grommet to protect the wire leads.



CAUTION

- Mount the SCO cutout only on a flat, level surface. Do not mount the SCO cutout directly on a Unistrut™ channel or other similar channels. Mounting the cutout on a Unistrut channel may cause the ear of the cutout to crack since the channel is unsupported. If you must install the cutout on a Unistrut channel, fasten a customer-supplied ¼-in.-thick mounting plate to the channel and then fasten the cutout to the plate. See Figure 5 for a drilling template.

Figure 5: Drilling Template

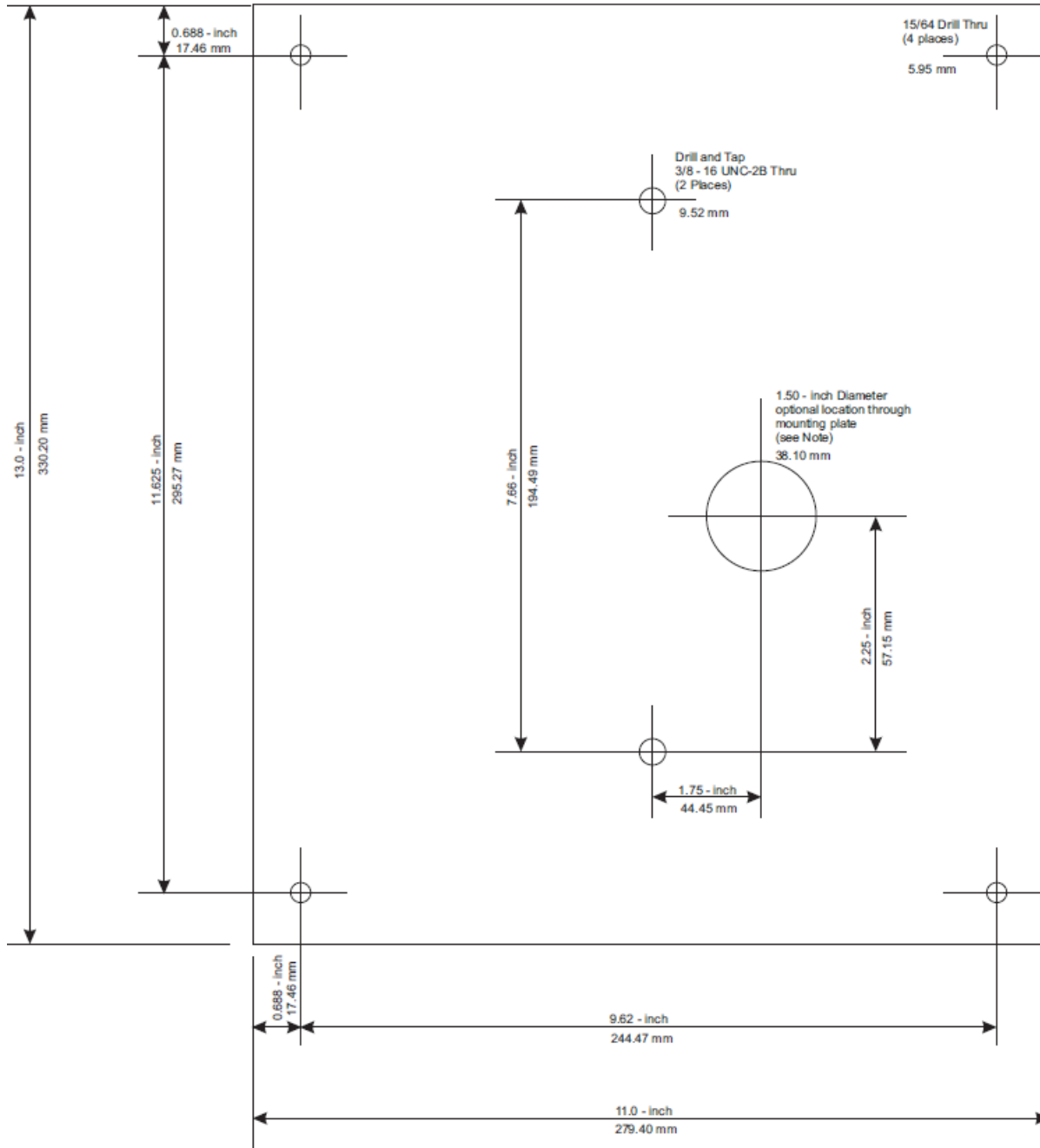

Note

See Figure 6 for the location of the interlock switch on the cutout. Suggested optional interlock switch wire location may vary according to wire routing method.

Figure 6: Connecting Wires to Interlock Switch Terminals (If Used)

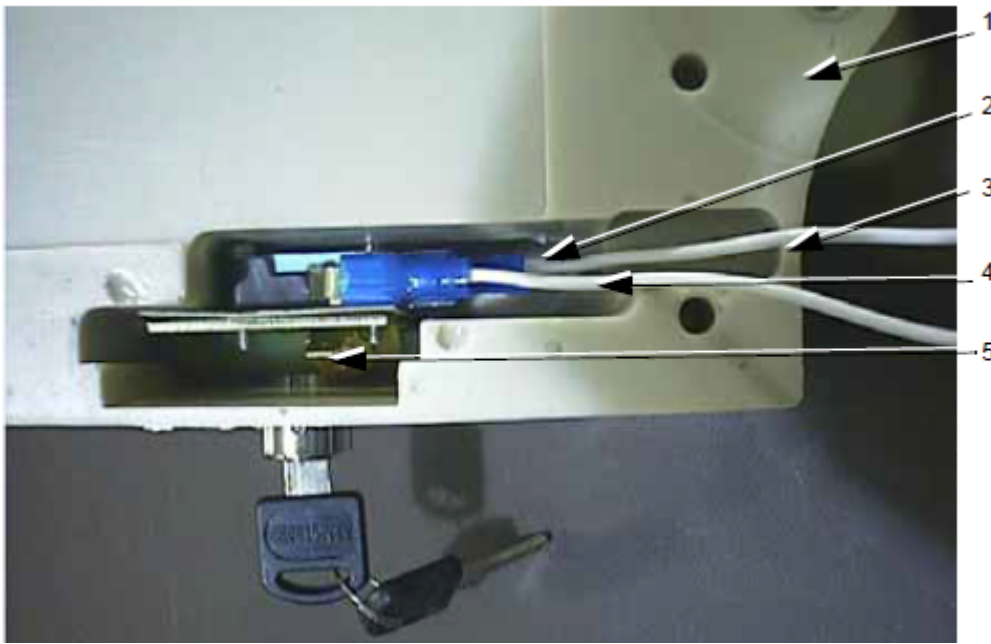

- | | |
|---|--|
| 1. Bottom of Cutout | 4. Interlock Switch Wiring to Terminal for W |
| 2. Interlock Switch Wiring to Terminal for NO | 5. Optional Interlock Switch Shield Terminal (If Used) |
| 3. Cut Out Thin Wall to Bring through Interlock Wire (Optional) | |

Individual SCO cutouts are normally mounted on a plate or in a NEMA enclosure. Multiple cutouts can also be mounted side-by-side on a plate or in a NEMA enclosure.

4.3.2 Mounting Individual Cutouts on Plate

To mount an individual SCO cutout on a plate, perform the following procedure:

1. Create a slot or hole for the spade connectors if the interlock switch is wired through the back of the panel as shown in [Figure 5](#).

i Note

If the switch is wired from the front side of the mounting plate, cut a thin wall found at the end of the molded channel as shown in [Figure 6](#), Item 3.

2. Drill two holes on the plate, and tap 3/8–16 x 1 UNC as shown in [Figure 5](#).
3. See [Figure 7](#).

Mount the cutout on the plate using two 3/8 –16 x 1 long hex head cap screws and two 3/8 flat washers or lock washers.

Figure 7: Mounting Cutout on Plate

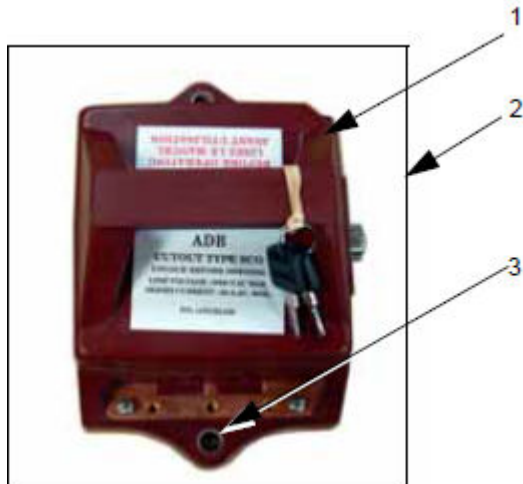

1. SCO Cutout
2. Mounting Plate
3. Screws and Lockwashers for Mounting Cutout

4.3.3 Mounting Individual Cutout in NEMA Enclosure (Sold Separately)

The SCO cutout can also be mounted in a NEMA 1 enclosure (part number 44C1793-1), as shown in [Figure 8](#). This enclosure is provided with a pre-drilled mounting panel and the SCO mounting hardware.



Note

The SCO cutout and the NEMA enclosure are sold and shipped separately. Assembly by a qualified contractor is required.

To mount the SCO cutout in a NEMA enclosure, perform the following procedure:

1. See [Figure 8](#).
Remove the mounting panel found inside the enclosure.



Note

The SCO mounting hardware (5) in [Figure 8](#) includes 3/8 hex head cap screws, 3/8 flat washers, and 3/8 lockwashers.

Figure 8: Mounting the Cutout in an External Enclosure

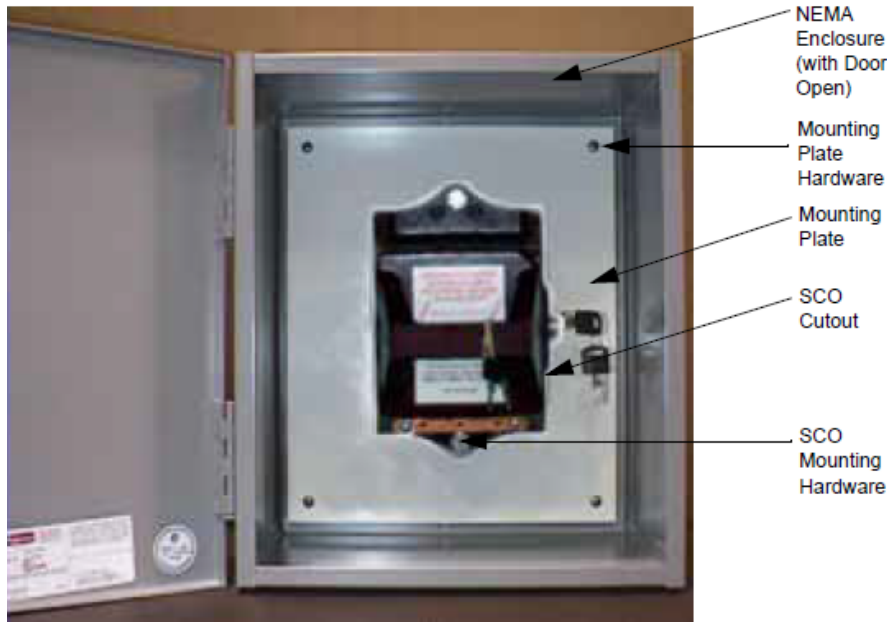

2. Drill four mounting holes in the back wall of the enclosure.
Drill input and output holes in the enclosure as required by site plans. Install contractor-supplied grommets or other suitable contractor-supplied cable clamps on all cable entrance and exit holes.
 3. Locate and mount the enclosure to the wall or other structure as required by site plans and specifications.
-



Note

The mounting hardware for mounting the enclosure to the wall is contractor-supplied.

4. Reinstall the SCO mounting panel.
5. Mount the SCO on the mounting plate with hardware supplied with the enclosure.
Refer to *Mounting Individual Cutouts on Plate* in this section.
6. Make the electrical connections.

4.3.4 Mounting Multiple SCO Cutouts Side-By-Side

See [Figure 9](#) for mounting multiple SCO cutouts side-by-side. [Figure 9](#) shows the minimum distance between two adjacent SCO cutouts. This ensures that enough room exists to get to the key to operate the locking device.

Figure 9: Installing Multiple Cutouts

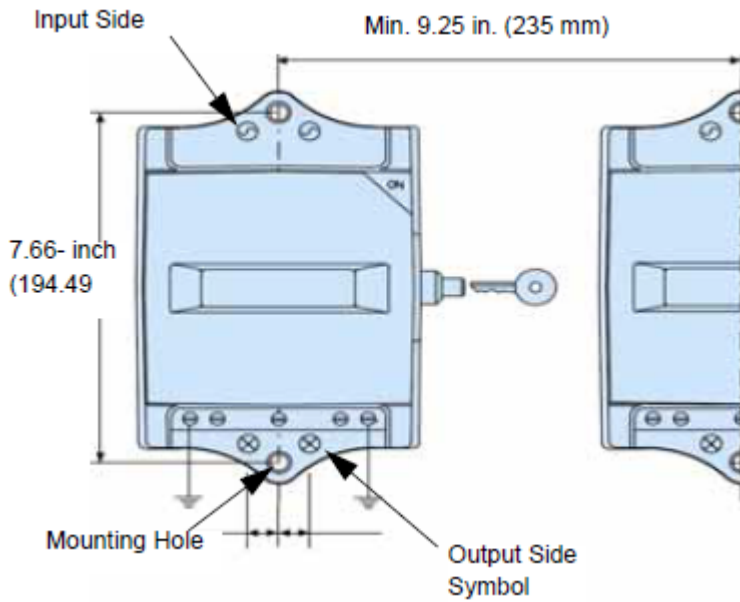

4.4 Individual Cutout Wiring

The CCR and load sides of the cutout are clearly marked and must not be reversed. See [Figure 10](#).

Figure 10: CCR-Side (Input) and Load-Side (Output) Symbols

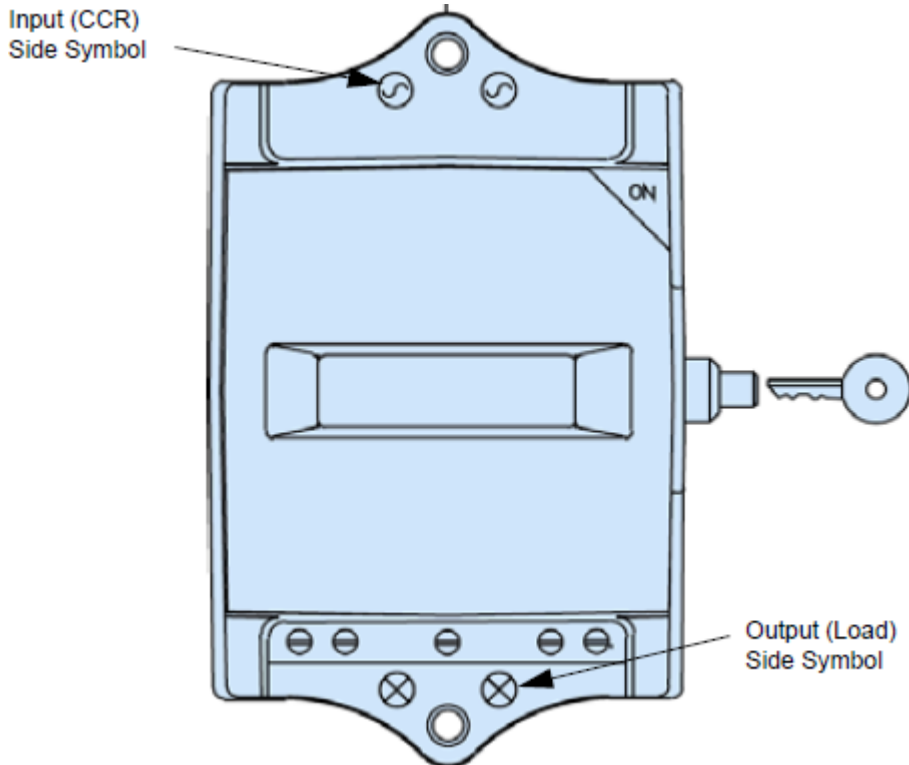



CAUTION

SCO cutouts should not be wired in any manner other than described in this manual without the approval of ADB Safegate.

To wire the SCO cutout, perform the following procedure:

1. See [Figure 2](#).

Unlock the lock (if depressed) using the key (4) and remove the cover (1).

2. See [Figure 6](#) and [Figure 11](#).

If required, wire the interlock switch. The interlock switch is used to further reduce the risk that the CCR is turned on when the CCR is in remote control.

The interlock switch is connected between the CCI terminal (the remote control power source) and the CC terminal (the ON remote control command).

Figure 11: Methods to Connect SCO Interlock Switch

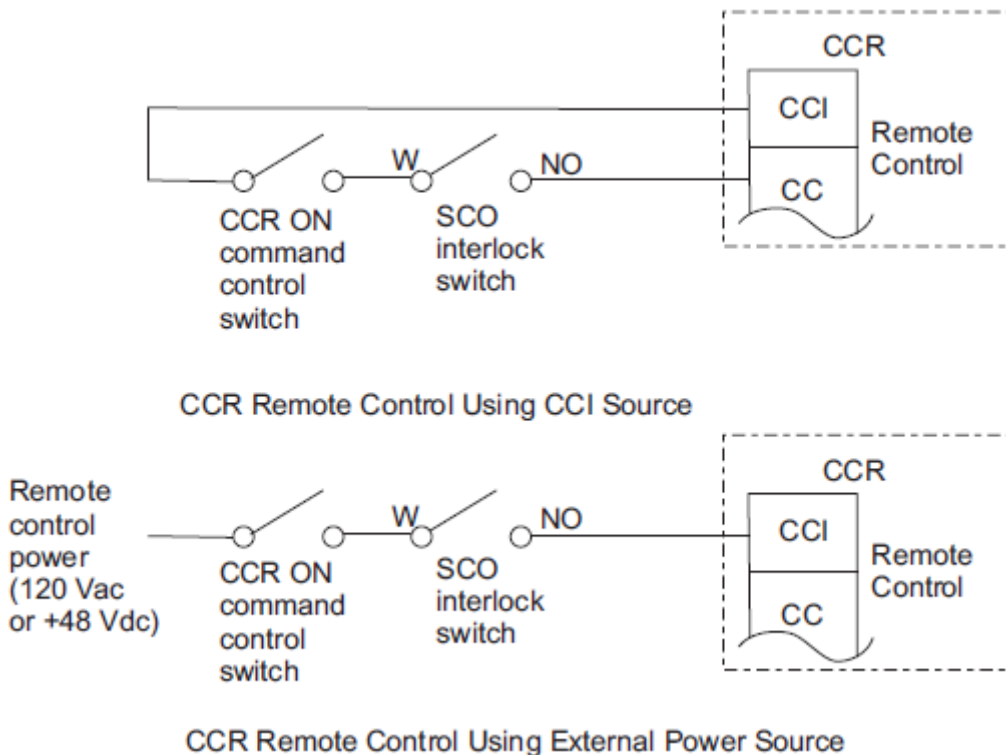

3. Connect two 16 or 14 AWG (1.0 or 1.50 mm²) (minimum), 600 V wires, terminated with a 0.25-inch female spade terminal, to the wiper (W) (see [Figure 6](#), Item 4) and normally open (NO) terminals (see [Figure 6](#), Item 2).

Use needle nose pliers, if necessary, to push the terminals on.

4. Bring the interlock wiring out through the mounting panel.

-OR-

Cut out the thin wall in the bottom of the cutout body and bring the interlock wiring through the cable channel (see [Figure 6](#), Item 3).

5. See [Figure 2](#).

Connect an earth ground wire to the SCO cutout ground terminal (8) using the same gauge wire as the L-824 wire. This is normally 6 or 8 AWG (13.0 mm² max) wire. Connect the other end of the wire to a known good earth ground in the vault according to the local or NEC requirements.

6. If using unshielded L-824 wire, connect the CCR input and output wires to the SCO cutout by performing the following procedure:
- See [Figure 2](#). Remove and discard the cutout clamp (11) and clamp screws (9) from the cutout. Only the grounding screws (8) should remain.

- Strip the input and output cable wires to ½ in. (13.0 mm) from the end of the wire. See [Figure 12](#). Make sure that the wire strands are not nicked or cut.

Figure 12: Stripping Unshielded L-824 Wire
Input/Output Cable



½ in. (13 mm)
16 mm max.

Cable Wire Stripped to ½ Inch

- See [Figure 13](#). Connect the input L-824 wire to the SCO cutout.



WARNING

Do not allow the end of the cable wire to extend beyond the input post more than 1/16 of an inch.

Figure 13: Connecting CCR Input Terminal Cables

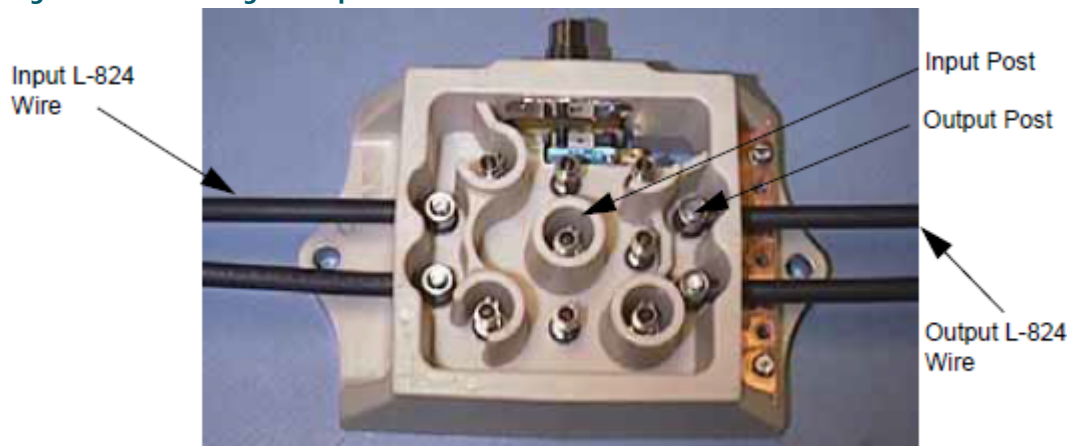

- Connect the output L-824 wire (4) to the SCO cutout.



WARNING

Do not allow the end of the cable wire to extend beyond the output post (3) more than 1/16 of an inch. (1.5 mm)

-OR-

7. If using shielded L-824 wire to connect output wires from the SCO cutout, performing the following procedure:

- See [Figure 14](#).

Strip the input and output cable wires to ½ inch (13 mm) from the end of the wire. Make sure that any plastic coating on the wire is cut off.

Figure 14: Stripping Shielded L-824 Wire

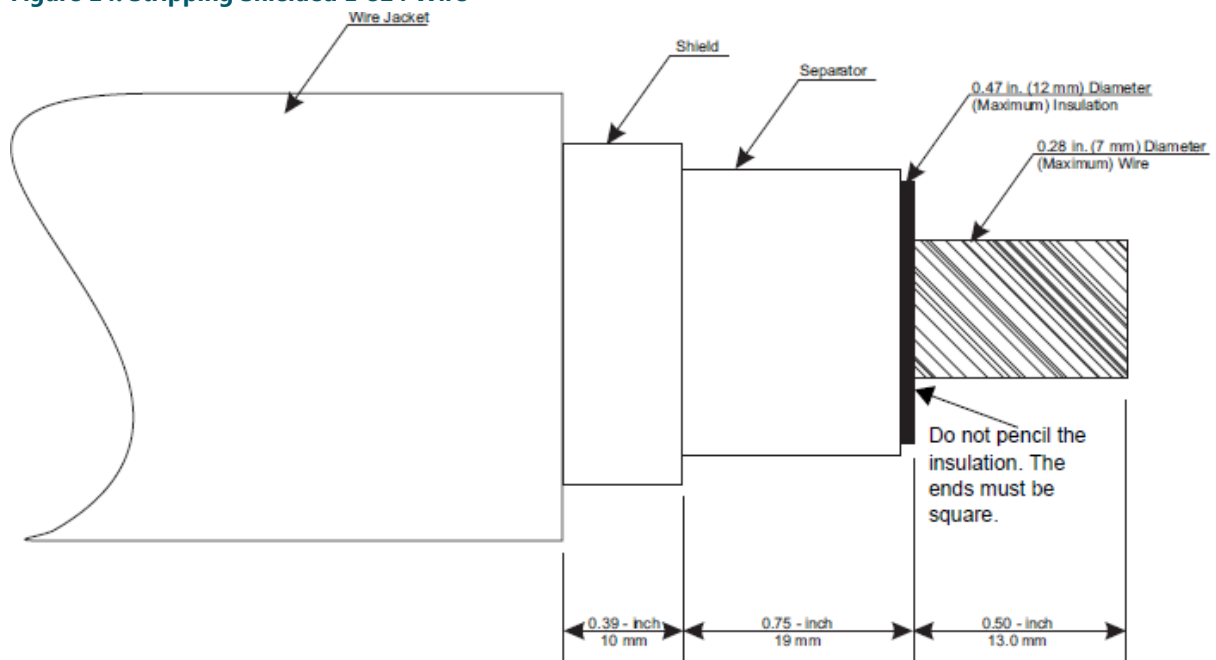

b) Connect the input L-824 wire (1) to the SCO cutout.



Note

Unshielded cable should be used between the CCR and the SCO.



WARNING

Do not allow the end of the cable wire to extend beyond the output post more than 1/16 of an inch. (1.5 mm)

c) See [Figure 2](#).

Remove the clamp (11).

d) See [Figure 13](#).

Connect each output wire (4) to the SCO cutout. Install the clamp. Make sure contact is made with the shield.



WARNING

Do not allow the end of the cable wire to extend beyond the output post more than 1/16 of an inch. (1.5 mm)

e) Close the SCO cutout and lock it.

f) See [Figure 3](#) for SCO cutout Positions.

4.4.1 Pre-Installed Cutout Installation

A pre-installed cutout typically requires the installation of only the cutout series circuit wiring and possibly the ground wiring.

To wire the pre-installed SCO cutout, perform the following procedure:

1. See [Figure 2](#). Unlock the lock (if depressed) using the key and remove the cover.
2. If using unshielded L-824 wire, connect the CCR input and output wires to the SCO cutout by performing the following procedure:
 - a) See [Figure 2](#). Remove and discard the cutout clamp (11) and clamp screws (9) from the cutout. Only the grounding screws (8) should remain.
 - b) Strip the input and output cable wires to ½ in. (13.0 mm) from the end of the wire. See [Figure 12](#). Make sure that the wire strands are not nicked or cut.
 - c) See [Figure 13](#). Connect the input L-824 wire (1) to the SCO cutout.



WARNING

Do not allow the end of the cable wire to extend beyond the input post (2) more than 1/16 of an inch. (1.5 mm)

- d) Connect the output L-824 wire (4) to the SCO cutout.



WARNING

Do not allow the end of the cable wire to extend beyond the output post (3) more than 1/16 of an inch. (1.5 mm)

-OR-

3. See [Figure 14](#). If using shielded L-824 wire to connect the output wires from the SCO cutout, performing the following procedure:
 - a) Strip the input and output cable wires to ½ inch (13 mm) from the end of the wire. Make sure that any plastic coating on the wire is cut off.
 - b) Connect the input L-824 wire (1) to the SCO cutout.



Note

A shield, if present, is not used.



WARNING

Do not allow the end of the cable wire to extend beyond the input post (2) more than 1/16 of an inch. (1.5 mm)

- c) See [Figure 2](#). Remove the clamp (11).
- d) See [Figure 13](#). Connect each output wire (4) to the SCO cutout. Install the clamp. Make sure contact is made with the shield.



WARNING

Do not allow the end of the cable wire to extend beyond the output post (4) more than 1/16 of an inch. (1.5 mm)

- e) Close the SCO cutout and lock it.

5.0 SCO Operation

This subsection provides the SCO cutout working positions.



DANGER

ARC FLASH AND ELECTRIC SHOCK HAZARD

Allow only qualified personnel to perform maintenance, troubleshooting, and repair tasks.

- Only persons who are properly trained and familiar with ADB Safegate equipment are permitted to service this equipment.
- An open airfield current circuit is capable of generating >5000 Vac and may appear OFF to a meter.
- Never unplug a device from a constant current circuit while it is operating. Arc flash may result.
- Disconnect and lock out electrical power.
- Always use safety devices when working on this equipment.
- Follow the recommended maintenance procedures in the product manuals.
- Do not service or adjust any equipment unless another person trained in first aid and CPR is present.
- Connect all disconnected equipment ground cables and wires after servicing equipment. Ground all conductive equipment.
- Use only approved ADB Safegate replacement parts. Using unapproved parts or making unapproved modifications to equipment may void agency approvals and create safety hazards.
- Check the interlock systems periodically to ensure their effectiveness.
- Do not attempt to service electrical equipment if standing water is present. Use caution when servicing electrical equipment in a high-humidity environment.
- Use tools with insulated handles when working with airfield electrical equipment

Failure to follow these warnings will result in death or equipment damage.

Refer to [Table 3](#) for the different working positions.



WARNING

Switch off the constant current regulator before manipulating the cutout.

Table 3: Cutout Working Positions

	Position A	Position B	Position C
Mode of operation	Allows the regulator to deliver current to the series circuit.	Maintenance can be done safely on the series circuit.	The series circuit insulation versus ground can be measured by applying the measurement voltage, max 9000 V DC, between the measurement socket (Item 3, Figure 2) and the ground strip (Item 8, Figure 2).
Diagram			
Cover			
Handle is	horizontal	turned 90° CCW from position A	turned 270° CCW from position A
The series circuit is	connected to the CCR	Disconnected from the CCR, shorted and grounded	disconnected from the CCR, shorted and connected to the measurement socket (Item 3, Figure 2)
The CCR is	delivering current to the series circuit	shorted and grounded	shorted and grounded
The interlock switch is	activated and allows the CCR to be ON	not activated and inhibits the CCR to be ON	activated and allows the regulator to be ON (operation in short circuit)
The cover	can be locked by the key	can be locked by the key	can be locked by the key

Notes

- The position of the cover intermediate between B and C, that is, turned 180 degrees from position A, cannot be used and the cover cannot be plugged into the body.
- An activated interlock switch means that the normally open contact is closed and that the normally closed contact is open. For interlocking with the CCR, only the normally open contact will be used.

6.0 Maintenance



WARNING

Switch off the constant current regulator before manipulating the cutout.

6.1 Introduction

This subsection provides the procedure for megging the circuit.

6.1.1 Megging Circuit

To meg the circuit, perform the following procedure:

1. Turn off and lock out the constant current regulator.
 2. See [Figure 3](#).
Position the top cover in the test and measure position.
 3. Place the positive (red) wire of the megger into the insulation measurement socket (3).
 4. See [Figure 2](#).
Connect the minus (black) wire of the megger on the ground terminal screw (7).
-



Note

The maximum voltage measurement is 9,000 Vdc.

5. Activate the megger and record the resistance reading.
6. When finished, restore the system to its original position.

6.2 Grounding Cover

A technique used during series circuit maintenance and troubleshooting procedures is to connect one of the constant current regulator output terminals to earth ground.

SCO Grounding Covers are now available to allow this to be quickly and easily accomplished. Two different Grounding Covers are used. Substituting the gray-colored SCO top cover (in the "Operation" position) grounds one side of the CCR output. Substituting the black-colored SCO top cover grounds the other side of the CCR output.

Ordering Code

Gray SCO Grounding Cover Part No. 63A1090/1

Black SCO Grounding Cover Part No.63A1090/2

Appendix A: SUPPORT

Our experienced engineers are available for support and service at all times, 24 hour/7 days a week. They are part of a dynamic organization making sure the entire ADB SAFEGATE is committed to minimal disturbance for airport operations.

ADB SAFEGATE Support

Live Technical Support - Americas

If at any time you have a question or concern about your product, just contact ADB SAFEGATE's technical service department. Trained in all areas of system issues, troubleshooting, quality control and technical assistance, our highly experienced Technical support specialists are available 24 hours a day, seven days a week to provide assistance over the phone.

ADB SAFEGATE **Americas Technical Service & Support (US & Canada): +1-800-545-4157**

ADB SAFEGATE Americas Technical Service & Support (International): +1-614-861-1304

During regular business hours, you can also Chat with a Service Technician. We look forward to working with you!

Before You Call

When you have an airfield lighting or system control system problem it is our goal to support airfield maintenance staff as quickly as possible. To support this effort we ask that you have the following information ready before calling.

- The *airport code*
- If not with an airport, then company name (prefer customer id number)
- Contact phone number and email address
- Product with part number preferable or product number
- Have you reviewed the product's manual and troubleshooting guide
- Do you have a *True RMS* meter available (and any other necessary tools)
- Be located with the product ready to troubleshoot



Note

For more information, see www.adbsafegate.com, or contact ADB SAFEGATE Support via email at support@adbsafegate.com or

Brussels: +32 2 722 17 11

Rest of Europe: +46 (0) 40 699 17 40

Americas: +1 614 861 1304. Press 3 for technical service or press 4 for sales support.

China: +86 (10) 8476 0106

A.1 ADB SAFEGATE Website

The ADB SAFEGATE website, www.adbsafegate.com, offers information regarding our airport solutions, products, company, news, links, downloads, references, contacts and more.

A.2 Recycling

A.2.1 Local Authority Recycling

The disposal of ADB SAFEGATE products is to be made at an applicable collection point for the recycling of electrical and electronic equipment. The correct disposal of equipment prevents any potential negative consequences for the environment and human health, which could otherwise be caused by inappropriate waste handling. The recycling of materials helps to conserve natural resources. For more detailed information about recycling of products, contact your local authority city office.

A.2.2 ADB SAFEGATE Recycling

ADB SAFEGATE is fully committed to environmentally-conscious manufacturing with strict monitoring of our own processes as well as supplier components and sub-contractor operations. ADB SAFEGATE offers a recycling program for our products to all customers worldwide, whether or not the products were sold within the EU.

ADB SAFEGATE products and/or specific electrical and electronic component parts which are fully removed/separated from any customer equipment and returned will be accepted for our recycling program.

All items returned must be clearly labeled as follows:

- For *ROHS/WEEE* Recycling
- Sender contact information (Name, Business Address, Phone number).
- Main Unit Serial Number.

ADB SAFEGATE will continue to monitor and update according for any future requirements for *EU directives* as and when *EU member states* implement new *regulations* and or *amendments*. It is our aim to maintain our *compliance plan* and assist our customers.

Company Addresses

ADB SAFEGATE	ADB SAFEGATE, Belgium: Leuvensesteenweg 585, B-1930 Zaventem Belgium
Contact: Tel.: +32 2 722 17 11, Fax: +32 2 722 17 64	Email: marketing@adbsafegate.com Internet: www.adbsafegate.com
Americas LLC	ADB SAFEGATE, Americas: 977 Gahanna Parkway, Columbus, OH 43230 USA
Contact: Tel.: +1 (614) 861 1304, Fax: +1 (614) 864 2069	Email: sales.us@adbsafegate.com Internet: www.adbsafegate.com
ADB SAFEGATE Sweden AB	ADB SAFEGATE, Sweden: Djurhagegatan 19 SE-213 76 Malmö Sweden
Contact: Tel.: +46 (0)40 699 17 00, Fax: +46 (0)40 699 17 30	Email: marketing@adbsafegate.com Internet: www.adbsafegate.com
ADB SAFEGATE Airfield Technologies Ltd. China	ADB SAFEGATE, China: Unit 603, D Block, CAMIC International Convention Center, No 3, Hua Jia Di East road, ChaoYang district, Beijing 100102 P.R. China
Contact: Tel.: +86 (10) 8476 0106, Fax: +86 (10) 8476 0090	Email: china@safegate.com Internet: www.adbsafegate.com
ADB SAFEGATE Germany GmbH	ADB SAFEGATE Germany GmbH, Mannheim: Konrad-Zuse-Ring 6, D-68163 Mannheim Germany
Contact: Tel.: +49 (621) 87 55 76-0, Fax: +49 (621) 87 55 76-55	Email: marketing@adbsafegate.com Internet: www.adbsafegate.com



Powering Your Airport Performance from Approach to Departure

adbsafegate.com

Copyright © ADB SAFEGATE, all rights reserved

