



## RELIANCE

Elevated Approach Centerline, Crossbar, Siderow, Threshold,  
Wingbar, End and Stopbar

# User Manual

UM-4001, Rev. 1.6, 2020/07/22



**ADB**  
**SAFEGATE**

The logo for ADB SAFEGATE features a stylized orange and yellow starburst icon above the text "ADB SAFEGATE". The text is in a bold, sans-serif font, with "ADB" on the top line and "SAFEGATE" on the bottom line.



## A.0 Disclaimer / Standard Warranty

### CE certification

The equipment listed as CE certified means that the product complies with the essential requirements concerning safety and hygiene. The European directives that have been taken into consideration in the design are available on written request to ADB SAFEGATE.

### ETL certification

The equipment listed as ETL certified means that the product complies with the essential requirements concerning safety and FAA Airfield regulations. The FAA directives that have been taken into consideration in the design are available on written request to ADB SAFEGATE.

### All Products Guarantee

ADB SAFEGATE will correct by repair or replacement per the applicable guarantee above, at its option, equipment or parts which fail because of mechanical, electrical or physical defects, provided that the goods have been properly handled and stored prior to installation, properly installed and properly operated after installation, and provided further that Buyer gives ADB SAFEGATE written notice of such defects after delivery of the goods to Buyer. Refer to the Safety section for more information on Material Handling Precautions and Storage precautions that must be followed.

ADB SAFEGATE reserves the right to examine goods upon which a claim is made. Said goods must be presented in the same condition as when the defect therein was discovered. ADB SAFEGATE further reserves the right to require the return of such goods to establish any claim.

ADB SAFEGATE's obligation under this guarantee is limited to making repair or replacement within a reasonable time after receipt of such written notice and does not include any other costs such as the cost of removal of defective part, installation of repaired product, labor or consequential damages of any kind, the exclusive remedy being to require such new parts to be furnished.

ADB SAFEGATE's liability under no circumstances will exceed the contract price of goods claimed to be defective. Any returns under this guarantee are to be on a transportation charges prepaid basis. For products not manufactured by, but sold by ADB SAFEGATE, warranty is limited to that extended by the original manufacturer. This is ADB SAFEGATE's sole guarantee and warranty with respect to the goods; there are no express warranties or warranties of fitness for any particular purpose or any implied warranties of fitness for any particular purpose or any implied warranties other than those made expressly herein. All such warranties being expressly disclaimed.

### Standard Products Guarantee

Products of ADB SAFEGATE manufacture are guaranteed against mechanical, electrical, and physical defects (excluding lamps) which may occur during proper and normal use for a period of two years from the date of ex-works delivery, and are guaranteed to be merchantable and fit for the ordinary purposes for which such products are made.



#### Note

See your sales order contract for a complete warranty description.

### FAA Certified product installed in the United States and purchased or funded with monies through the Airport Improvement Program (AIP) installations guarantee

ADB SAFEGATE L858 Airfield Guidance Signs are warranted against mechanical and physical defects in design or manufacture for a period of 2 years from date of installation, per FAA AC 150/5345-44 (applicable edition).

ADB SAFEGATE L858(L) Airfield Guidance Signs are warranted against electrical defects in design or manufacture of the LED or LED specific circuitry for a period of 4 years from date of installation, per FAA EB67 (applicable edition).

ADB SAFEGATE LED light fixtures (with the exception of obstruction lighting) are warranted against electrical defects in design or manufacture of the LED or LED specific circuitry for a period of 4 years from date of installation, per FAA EB67 (applicable edition).

**Note**

See your sales order contract for a complete warranty description.

---

**Liability**

---

**WARNING**

Use of the equipment in ways other than described in the catalog leaflet and the manual may result in personal injury, death, or property and equipment damage. Use this equipment only as described in the manual.

---

ADB SAFEGATE cannot be held responsible for injuries or damages resulting from non-standard, unintended uses of its equipment. The equipment is designed and intended only for the purpose described in the manual. Uses not described in the manual are considered unintended uses and may result in serious personal injury, death or property damage.

Unintended uses, includes the following actions:

- Making changes to equipment that have not been recommended or described in this manual or using parts that are not genuine ADB SAFEGATE replacement parts or accessories.
- Failing to make sure that auxiliary equipment complies with approval agency requirements, local codes, and all applicable safety standards if not in contradiction with the general rules.
- Using materials or auxiliary equipment that are inappropriate or incompatible with your ADB SAFEGATE equipment.
- Allowing unskilled personnel to perform any task on or with the equipment.

**© ADB SAFEGATE BV**

This manual or parts thereof may not be reproduced, stored in a retrieval system, or transmitted, in any form or by any means, electronic, mechanical, photocopying, recording, nor otherwise, without ADB SAFEGATE BV's prior written consent.

This manual could contain technical inaccuracies or typographical errors. ADB SAFEGATE BV reserves the right to revise this manual from time to time in the contents thereof without obligation of ADB SAFEGATE BV to notify any person of such revision or change. Details and values given in this manual are average values and have been compiled with care. They are not binding, however, and ADB SAFEGATE BV disclaims any liability for damages or detriments suffered as a result of reliance on the information given herein or the use of products, processes or equipment to which this manual refers. No warranty is made that the use of the information or of the products, processes or equipment to which this manual refers will not infringe any third party's patents or rights. The information given does not release the buyer from making their own experiments and tests.

# TABLE OF CONTENTS

<b>1.0 Safety</b> .....	<b>1</b>
1.1 Safety Messages .....	1
1.1.1 Introduction to Safety .....	2
1.1.2 Intended Use .....	2
1.1.3 Material Handling Precautions: Storage .....	3
1.1.4 Operation Safety .....	3
1.1.5 Maintenance Safety .....	3
1.1.6 Material Handling Precautions, ESD .....	4
<b>2.0 About this Manual</b> .....	<b>5</b>
2.1 How to Work with the Manual .....	5
2.2 Abbreviations and Terms .....	5
<b>3.0 Introduction</b> .....	<b>7</b>
3.1 Overview .....	7
3.2 Approach Centerline, Crossbar, Siderow, Threshold, Wingbar, End, Stopbar - L-862S(L), L-862E(L) .....	7
3.3 Monitoring (Option) .....	9
<b>4.0 Installation</b> .....	<b>11</b>
4.1 Unpacking the Unit .....	11
4.2 Required Tools .....	11
4.3 Mounting Supports .....	12
4.3.1 Male Breakable Coupling .....	12
4.3.2 Conduit .....	13
4.3.3 Tubular Mast .....	13
4.3.4 Lattice Mast .....	14
4.4 Installation of the Fixture .....	15
4.5 Aligning the Fixture with the Standard Alignment Tool .....	17
4.6 Aligning the Fixture with the Electronic Alignment Tool .....	22
4.7 Removing the Alignment Tool .....	26
<b>5.0 Operation</b> .....	<b>27</b>
5.1 IQ function load (option) .....	27
5.2 2A-system .....	27
<b>6.0 Troubleshooting</b> .....	<b>29</b>
<b>7.0 Maintenance</b> .....	<b>31</b>
7.1 Basic Maintenance Program .....	31
7.2 Workshop Maintenance .....	32
7.2.1 Complete Electronic Cartridge .....	33
7.2.2 Complete Optical Cartridge .....	35
7.2.3 Bird Deterrent .....	37
7.2.4 Latch Replacement with the Block .....	38
7.2.5 Fuse Resistor (Monitoring Option) .....	41
7.3 Fixture Operation Test .....	42
<b>8.0 Spare Parts</b> .....	<b>43</b>
8.1 Ordering Code LEAP .....	43
8.2 Components .....	44
8.3 Accessories .....	45
8.4 Screws Overview .....	45
<b>A.0 POWER TABLE</b> .....	<b>47</b>
<b>B.0 CABLE LOSS</b> .....	<b>49</b>
<b>C.0 SUPPORT</b> .....	<b>51</b>
C.1 ADB SAFEGATE Website .....	51

C.2 Recycling .....	52
C.2.1 Local Authority Recycling .....	52
C.2.2 ADB SAFEGATE Recycling .....	52

## List of Figures

Figure 1: Light installation on a breakable coupling .....	15
Figure 2: Light installation on another mounting support .....	16
Figure 3: Earthing wire connection .....	16
Figure 4: Alignment tool installation - part 1 .....	17
Figure 5: Alignment tool installation - part 2 .....	18
Figure 6: Alignment tool adjustment - part 1 .....	19
Figure 7: Alignment tool adjustment - part 2 .....	19
Figure 8: Alignment tool adjustment - part 3 .....	20
Figure 9: Light leveling .....	20
Figure 10: Light alignment in azimuth .....	21
Figure 11: Light elevation adjustment - part 1 .....	21
Figure 12: Light elevation adjustment - part 2 .....	22
Figure 13: Light alignment in azimuth, without toe-in .....	23
Figure 14: Light alignment in azimuth, with toe-in .....	24
Figure 15: Coarse adjustment .....	24
Figure 16: Alignment tool adjustment - part 1 .....	25
Figure 17: Alignment tool adjustment - part 2 .....	26
Figure 18: Alignment tool removal .....	26
Figure 19: Electronic cartridge removal .....	33
Figure 20: Electronic cartridge installation .....	34
Figure 21: Optical cartridge removal .....	35
Figure 22: Optical cartridge installation .....	36
Figure 23: Bird deterrent removal .....	37
Figure 24: Latch removal .....	38
Figure 25: Block installation and replacement - part 1 .....	38
Figure 26: Block installation and replacement - part 2 .....	39
Figure 27: Block installation and replacement - part 3 .....	40
Figure 28: Block installation and replacement - part 4 .....	40
Figure 29: Block installation and replacement - part 5 .....	41





## List of Tables

Table 1: Troubleshooting guide ..... 29



# 1.0 Safety

## Introduction to Safety

This section contains general safety instructions for installing and using ADB SAFEGATE equipment. Some safety instructions may not apply to the equipment in this manual. Task- and equipment-specific warnings are included in other sections of this manual where appropriate.

## 1.1 Safety Messages

### HAZARD Icons used in the manual

For all HAZARD symbols in use, see the Safety section. All symbols must comply with ISO and ANSI standards.

Carefully read and observe all safety instructions in this manual, which alert you to safety hazards and conditions that may result in personal injury, death or property and equipment damage and are accompanied by the symbol shown below.



**WARNING**

Failure to observe a warning may result in personal injury, death or equipment damage.



**DANGER - Risk of electrical shock or ARC FLASH**

Disconnect equipment from line voltage. Failure to observe this warning may result in personal injury, death, or equipment damage. ARC Flash may cause blindness, severe burns or death.



**WARNING - Wear personal protective equipment**

Failure to observe may result in serious injury.



**WARNING - Do not touch**

Failure to observe this warning may result in personal injury, death, or equipment damage.



**CAUTION**

Failure to observe a caution may result in equipment damage.

### Qualified Personnel



**Important Information**

The term **qualified personnel** is defined here as individuals who thoroughly understand the equipment and its safe operation, maintenance and repair. Qualified personnel are physically capable of performing the required tasks, familiar with all relevant safety rules and regulations and have been trained to safely install, operate, maintain and repair the equipment. It is the responsibility of the company operating this equipment to ensure that its personnel meet these requirements.

Always use required personal protective equipment (PPE) and follow safe electrical work practice.

### 1.1.1 Introduction to Safety



#### CAUTION

##### Unsafe Equipment Use

This equipment may contain electrostatic devices, hazardous voltages and sharp edges on components

- Read installation instructions in their entirety before starting installation.
- Become familiar with the general safety instructions in this section of the manual before installing, operating, maintaining or repairing this equipment.
- Read and carefully follow the instructions throughout this manual for performing specific tasks and working with specific equipment.
- Make this manual available to personnel installing, operating, maintaining or repairing this equipment.
- Follow all applicable safety procedures required by your company, industry standards and government or other regulatory agencies.
- Install all electrical connections to local code.
- Use only electrical wire of sufficient gauge and insulation to handle the rated current demand. All wiring must meet local codes.
- Route electrical wiring along a protected path. Make sure they will not be damaged by moving equipment.
- Protect components from damage, wear, and harsh environment conditions.
- Allow ample room for maintenance, panel accessibility, and cover removal.
- Protect equipment with safety devices as specified by applicable safety regulations
- If safety devices must be removed for installation, install them immediately after the work is completed and check them for proper functioning prior to returning power to the circuit.

**Failure to follow this instruction can result in serious injury or equipment damage**

### Additional Reference Materials



#### Important Information

- IEC - International Standards and Conformity Assessment for all electrical, electronic and related technologies.
- IEC 60364 - Electrical Installations in Buildings.
- FAA Advisory: AC 150/5340-26 (current edition), Maintenance of Airport Visual Aid Facilities.
- Maintenance personnel must refer to the maintenance procedure described in the ICAO Airport Services Manual, Part 9.
- ANSI/NFPA 79, Electrical Standards for Metalworking Machine Tools.
- National and local electrical codes and standards.

### 1.1.2 Intended Use



#### CAUTION

##### Use this equipment as intended by the manufacturer

This equipment is designed to perform a specific function, do not use this equipment for other purposes

- Using this equipment in ways other than described in this manual may result in personal injury, death or property and equipment damage. Use this equipment only as described in this manual.

**Failure to follow this instruction can result in serious injury or equipment damage**

### 1.1.3 Material Handling Precautions: Storage



#### CAUTION

##### Improper Storage

Store this equipment properly

- If equipment is to be stored prior to installation, it must be protected from the weather and kept free of condensation and dust.

**Failure to follow this instruction can result in equipment damage**

### 1.1.4 Operation Safety



#### CAUTION

##### Improper Operation

Do Not Operate this equipment other than as specified by the manufacturer

- Only qualified personnel, physically capable of operating the equipment and with no impairments in their judgment or reaction times, should operate this equipment.
- Read all system component manuals before operating this equipment. A thorough understanding of system components and their operation will help you operate the system safely and efficiently.
- Before starting this equipment, check all safety interlocks, fire-detection systems, and protective devices such as panels and covers. Make sure all devices are fully functional. Do not operate the system if these devices are not working properly. Do not deactivate or bypass automatic safety interlocks or locked-out electrical disconnects or pneumatic valves.
- Protect equipment with safety devices as specified by applicable safety regulations.
- If safety devices must be removed for installation, install them immediately after the work is completed and check them for proper functioning.
- Route electrical wiring along a protected path. Make sure they will not be damaged by moving equipment.
- Never operate equipment with a known malfunction.
- Do not attempt to operate or service electrical equipment if standing water is present.
- Use this equipment only in the environments for which it is rated. Do not operate this equipment in humid, flammable, or explosive environments unless it has been rated for safe operation in these environments.
- Never touch exposed electrical connections on equipment while the power is ON.

**Failure to follow these instructions can result in equipment damage**

### 1.1.5 Maintenance Safety



#### DANGER

##### Electric Shock Hazard

This equipment may contain electrostatic devices

- Do not operate a system that contains malfunctioning components. If a component malfunctions, turn the system OFF immediately.
- Disconnect and lock out electrical power.
- Allow only qualified personnel to make repairs. Repair or replace the malfunctioning component according to instructions provided in its manual.

**Failure to follow these instructions can result in death or equipment damage**

### 1.1.6 Material Handling Precautions, ESD



#### CAUTION

##### Electrostatic Sensitive Devices

This equipment may contain electrostatic devices

- Protect from electrostatic discharge.
- Electronic modules and components should be touched only when this is unavoidable e.g. soldering, replacement.
- Before touching any component of the cabinet you shall bring your body to the same potential as the cabinet by touching a conductive earthed part of the cabinet.
- Electronic modules or components must not be brought in contact with highly insulating materials such as plastic sheets, synthetic fiber clothing. They must be laid down on conductive surfaces.
- The tip of the soldering iron must be grounded.
- Electronic modules and components must be stored and transported in conductive packing.

**Failure to follow this instruction can result in equipment damage**

## 2.0 About this Manual

This document includes RELIANCE™ unidirectional elevated light fixture information with a focus on safety, installation and maintenance procedures.



### Note

Refer to [www.adbsafegate.com](http://www.adbsafegate.com) for more information.

### Important

It is very important to read this document before any work is started.

## 2.1 How to Work with the Manual

1. Familiarize yourself with the structure and content.
2. Carry out the actions completely and in the given sequence.

## 2.2 Abbreviations and Terms

Abbreviations and terms	Description
FAA	Federal Aviation Administration
FOD	Foreign Object Debris
ICAO	International Civil Aviation Organization
IEC	International Electrical Committee
ISO	International Standardization Organization
LEAP	LED Elevated Approach Light
LED	Light Emitting Diode
MCPCB	Metal Core Printed Circuit Board
Mounting support	A piece of equipment, on which the fixture is installed.
Toe-in	The toe-in angle is the angle the beam of light makes with the longitudinal axis of the runway or taxiway.





## 3.0 Introduction

### 3.1 Overview



#### Note

Refer to [Spare Parts](#) chapter for a complete overview of the fixture in all available versions.



### 3.2 Approach Centerline, Crossbar, Siderow, Threshold, Wingbar, End, Stopbar - L-862S(L), L-862E(L)

#### Compliance with Standards (current Versions)

FAA	L-862S(L) AC 150/5345-46 and the FAA Engineering Brief No. 67
ICAO	Annex 14 Volume I
EASA	CS-ADR-DSN
US MIL	UFC 3-535-01, section 3-1.4
NATO	STANAG 3316
Canada	TP 312

#### Uses

##### ICAO

- Approach Centerline and Cross Bar
- Approach Siderow
- Runway Threshold and Threshold Wing Bar
- Runway End
- Stop Bar

## FAA

- Stop Bar L-862S(L)
- Runway Threshold L-862E(L)
- Runway End L-862E(L)

## Features and Benefits

- RELIANCE™ unidirectional elevated light fixtures are available in three versions:
  - IQ with integrated ILCMS
  - Monitored with integrated fail-open technology
  - Non-Mon without monitoring functionality

### Efficiency

- High-intensity
- Use less than 50 W, with a Power Factor of 0.95, compared to incandescent fixtures that require 150 W or 200 W lamps.
- Installation on same mounting device as most elevated halogen lights, for a straightforward replacement.
- Leveling and aiming in azimuth of the light are easily performed with the dedicated aiming device.
- Two opposite screws ensure easy and stable leveling.
- Fully dimmable lights, respecting the response curve of traditional halogen lights.
- Available in IQ 2A functionality for use in RELIANCE Intelligent Lighting (ILCMS) for further power savings and individual intensity control.

### Sustainability

- Average MTBF of 56.000 hours at full-intensity and more than 200.000 hours under typical operating conditions, resulting in significant reduction of ongoing maintenance costs and periodic relamping expenses.
- Low-profile and small in size to withstand heaviest jet blast, even when installed at threshold / runway end.
- When quartz-incandescent fixtures are replaced with LED fixtures, airport staff can add more lights without increasing CCR size.
- Limits cost for supporting equipment such as isolation transformers and CCRs to strict minimum.
- Use of LED light source eliminates filter replacement and color shifts when viewed at various angles or CCR step settings.
- IP67 design prevents water, dust and insect entry.

### Safety

- Rugged lightning protection that complies with ANSI/IEEE C62.41-1991 Location Category C2 given in FAA Eng. Brief 67. Category C2 is defined as a 1.2/50  $\mu$ S – 8/20  $\mu$ S combination wave, with a peak voltage of 10.000 V and a peak current of 5.000 A.
- Optionally, LED lights can be equipped with an internal monitoring function of the individual light source. In case of a defect, the LED light automatically disconnects from the secondary side of the isolation transformer, resulting in an open circuit condition. Therefore external lamp fault detection devices of Constant Current Regulators and Individual Lamp Control and Monitoring Systems (ILCMS) can be used to monitor failed lights.

## Power Supply

Lights have been designed to work with any IEC- or FAA-compliant transformer up to 150 W. See the manual for calculation of actual circuit VA loads.



### Note

- Refer to the appendix of user manual for the RELIANCE elevated lights for a complete power table and the cable loss formula.
- Refer to the annex section.

## Operating Conditions

Operating temperature	-55°C to +50°C / -58°F to 122°F
Storage temperature	60 °C to +80 °C / -76 °F to +176 °F
Humidity	<95% non condensing

## 3.3 Monitoring (Option)

The monitoring option is available. You can use the monitoring option with the Lamp Fault Detection of Constant Current Regulators (CCR) or with Individual Light Control and Monitoring Systems (ILCMS) that check the status of the light by performing a continuity test on the secondary of the ILCMS remote module. The monitoring option does a check on the light. In case of a failure of the light, the failure is detected by the electronics embedded in the light.



### Note

Contact your local ADB SAFEGATE sales representative for information on the compatibility of the ILCMS system with the light.



## 4.0 Installation

This section describes how to install the complete fixture.



### Note

Refer to the [Maintenance](#) chapter for information on how to replace parts of the fixture.

### 4.1 Unpacking the Unit

#### Important

To reduce the risk of damaging the light assembly, unpack the RELIANCE light fixtures at the installation site. If damage to any equipment is noted, file a claim form with the carrier immediately.

When receiving the light fixture, open the box and verify that the characteristics of the light fixture correspond to the design requirements, such as type, color etc.



#### WARNING

Do not damage the cable insulation.

### 4.2 Required Tools

The following tools are recommended for installation:

- Open spanners, 10 and 50 mm
- Standard alignment tool, if applicable
- Electronic alignment tool, if applicable

#### Tip

You can use the standard alignment tool for ground mounted fixtures up to a height of 2 m. Use electronic alignment tool for fixtures on masts, when it is not possible to reach the top of the mast in its upright position. Typically, the electronic alignment tool is used for fixtures on tiltable masts.



### Note

Refer to the [Mounting Supports](#) section for instructions on how to earth the mounting support.



#### DANGER

- Only install the fixture on mounting supports:
  - That ADB SAFEGATE has approved
  - That are installed according to the Instruction Manual of the mounting support
  - Failure to do so can result in a highly dangerous situation of FOD, with potentially lethal consequences
- Do not damage the cable insulation.
- Make sure the power to the series circuit is OFF when you install or remove any fixture.
- Make sure that the installation, alignment and the position of the fixture complies with FAA Advisory circular AC 150/5340-30 (latest revision) and ICAO Annex 14 (to know the correct elevation and toe-in for the fixture related to its position, see the latter).



## WARNING



- Use protective gloves and face protection.
- The female threads for the fixation and adjustment screws are treated with a corrosion inhibitor. This product, when in contact with your the eyes or your skin, can cause serious irritations. It can be harmful to inhale or ingest this product!
- If your eyes or skin come into contact with this product, rinse abundantly. If you inhale or ingest this product, contact a physician immediately.



## NOTICE

Make sure that:

- The fixture is powered from a 6.6 A series circuit.
- The series circuit is powered by a Constant Current Regulator that complies with IEC 61822 or FAA AC 5345-10 (latest revision).
- The transformer is series isolation transformer that complies with IEC 61823 or FAA AC 5345-47 (latest revision); the power of the series transformer shall not exceed 200 W.
- The mounting support is correctly earthed. Failure to do so will void the warranty for all damages that occur as a result of voltage surges.

---

## 4.3 Mounting Supports

The fixture can be mounted on different mounting supports:

- Male breakable coupling
- Conduit
- Tubular mast
- Lattice mast

### 4.3.1 Male Breakable Coupling

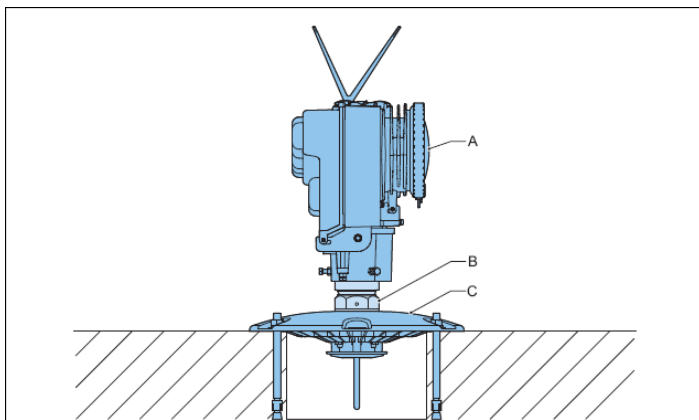

A Fixture  
B Male breakable coupling  
C Support (example)

The breakable coupling has a male thread at the bottom, so it can be installed on several types of supports.



**Note**

Refer to [Conduit](#) section for the female breakable coupling drawing.

**4.3.2 Conduit**

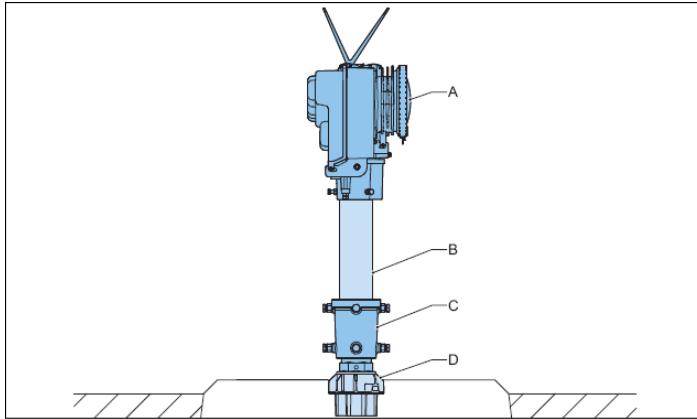

- A Fixture
- B Conduit
- C Female breakable coupling
- D Support (example)

The conduit is installed on a female breakable coupling. The breakable coupling has a male thread at the bottom, so it can be installed on several types of supports.



**Note**

Refer to [Male Breakable Coupling](#) section for the male breakable coupling drawing.

**4.3.3 Tubular Mast**

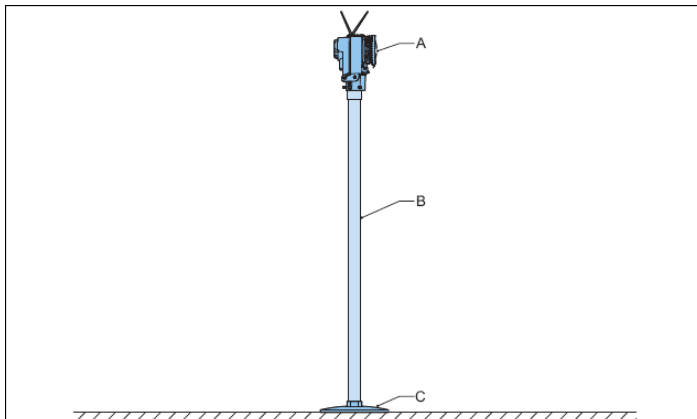

- A Fixture
- B Mast
- C Ground level

The tubular masts are directly installed on the ground. In some instances, the mast can be tilted.



**Note**

Refer to [Lattice Mast](#) section for the lattice mast drawing.

### 4.3.4 Lattice Mast

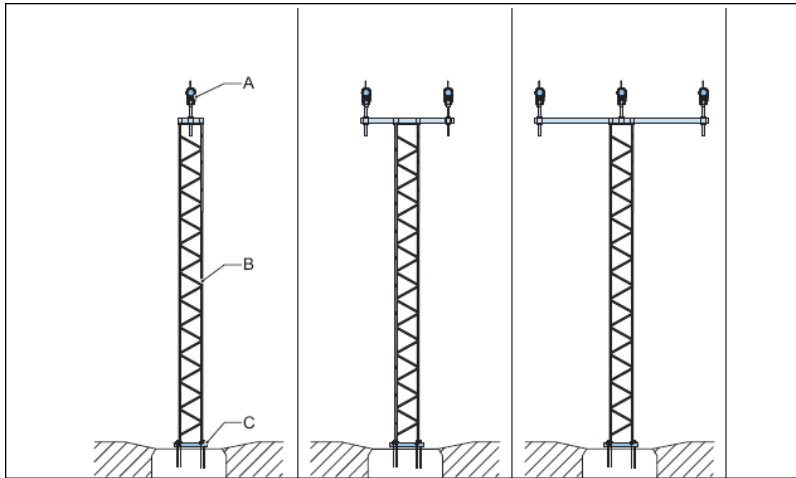

- A Fixture
- B Mast
- C Ground level

The lattice masts are directly installed on the ground. In some instances, the mast can be tilted.

---



#### Note

Refer to [Tubular Mast](#) section for the lattice mast drawing.

---



## 4.4 Installation of the Fixture

### Preparing the fixture

1. Make sure that the fixture is operationally tested.

---

**i Note** Refer to the [Fixture Operation Test](#) section for further information.

---

2. Choose to install the fixture on a breakable coupling or on another mounting support.

### Installation on a breakable coupling

1. Loosen the lock nuts (A).
2. Loosen the fixation screws (B).
3. Install the breakable coupling on the fixture. Do not tighten the fixation screws (B).
4. Connect the plug to the receptacle of the transformer.
5. Install the breakable coupling on the conduit elbow or base plate.

**Figure 1: Light installation on a breakable coupling**

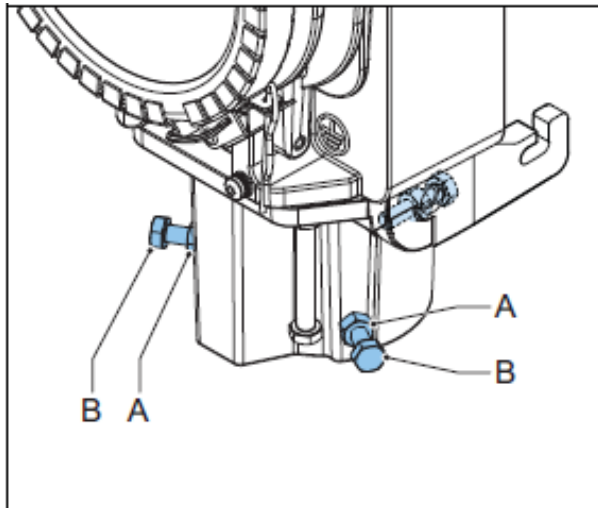

---

**i NOTICE** Do not turn the fixture. This prevents you from twisting the cable.

---

### Installation on other mounting support

6. Loosen the lock nuts (A).
7. Loosen the fixation screws (B).
8. Install the breakable coupling on the fixture. Do not tighten the fixation screws (B).
9. Connect the plug to the receptacle of the transformer.

10. Install the breakable coupling on the conduit elbow or base plate.

**Figure 2: Light installation on another mounting support**

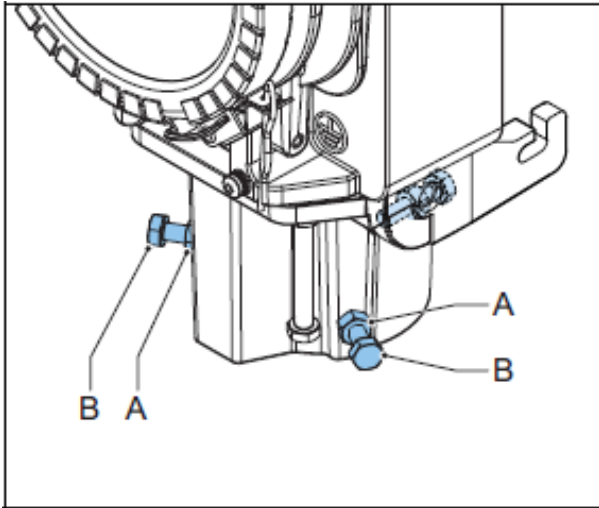

**NOTICE**

Do not turn the fixture. This prevents you from twisting the cable.

---

**Finish**

11. Connect the earthing wire from the mounting support to the earthing connection (A).

12. Align the fixture with:

- a) the standard alignment tool, or
  - b) the electronic alignment tool.
- 



**Note**

Refer to [Aligning the Fixture with the Standard Alignment Tool](#) or [Aligning the Fixture with the Electronic Alignment Tool](#).

---

**Figure 3: Earthing wire connection**

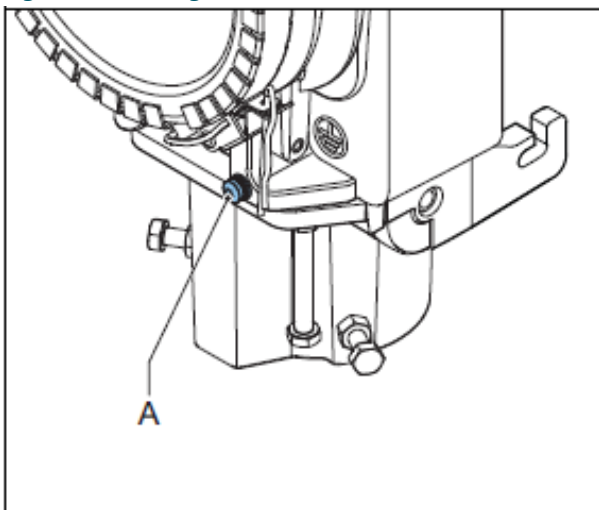

## 4.5 Aligning the Fixture with the Standard Alignment Tool

Look at a reference mark through the alignment tool to align the fixture in azimuth. Depending on the position of the fixture, the reference mark may be another fixture in the same row or a stick installed for this purpose.

It is possible to take reference marks at 90, 180 or 270 degrees from the centerline. Typically, you can use this function for fixtures in a barrette, a side row, a threshold or a wing bar.

### Installation of the alignment tool

1. Install the alignment tool (A) over the cooling fin (B) of the optical cartridge.
2. Make sure that the two lower hooks (C) lock the alignment tool on the optical cartridge.
3. Tighten the wing screws (D).
4. Check if the alignment tool is level, examine the spirit level (E).
5. Turn the alignment tool 90, 180 or 270 degrees into the direction of the light.

**Figure 4: Alignment tool installation - part 1**

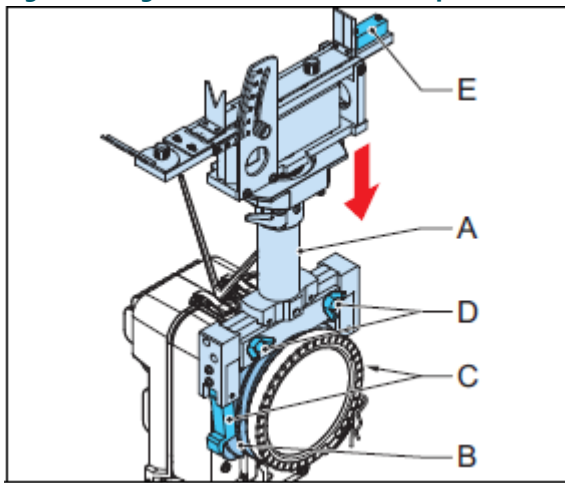

### Tip

**Turn the alignment tool 90, 180 or 270 degrees, if necessary.**

1. Loosen the clamps (A).
2. Pull the knob (B) and hold it there.
3. Turn the upper side of the alignment tool (C) for 90, 180 or 270 degrees.
4. Release the knob.
5. Turn the upper side of the alignment tool slightly until the knob fits into an opening.

Now you cannot turn the upper side of the alignment tool until you pull the knob again.

6. Tighten the clamps.

**Figure 5: Alignment tool installation - part 2**

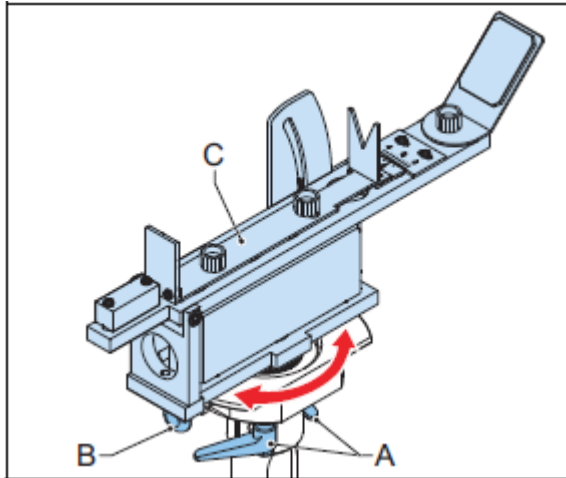

**Adjustment of the alignment tool for the required toe-in**

1. Loosen the knob (A).
2. Adjust the position of the sighting device (B) to the required toe-in. You can read the toe-in on the scale (C).

## Fast path

Make sure that you adjust the alignment tool in the correct toe-in direction.

3. Tighten the knob (A).

**Figure 6: Alignment tool adjustment - part 1**

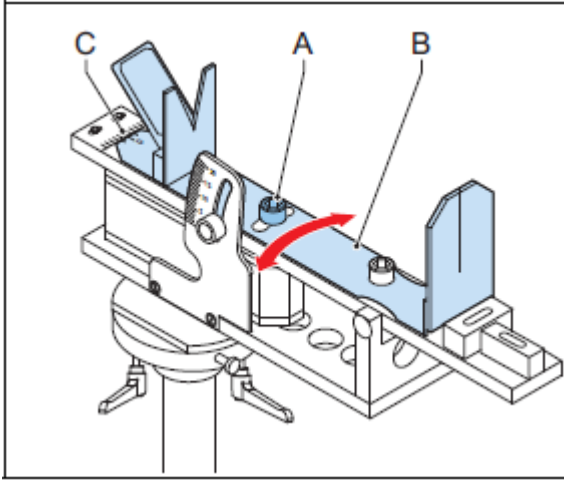

### Adjustment of the alignment tool for the required elevation

1. Loosen the knob (A).
2. Adjust the position of the sighting device (B) to the required toe-in by reading the toe-in on the scale (C).
3. Tighten the knob (A).

**Figure 7: Alignment tool adjustment - part 2**

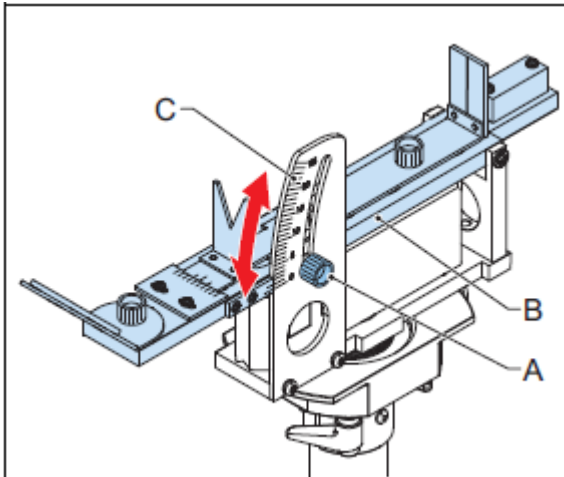

### Loosening procedure of the elevation screws

1. Loosen the lock nuts (A) and (B).
2. Loosen the elevation screws (C) and (D).

**Figure 8: Alignment tool adjustment - part 3**

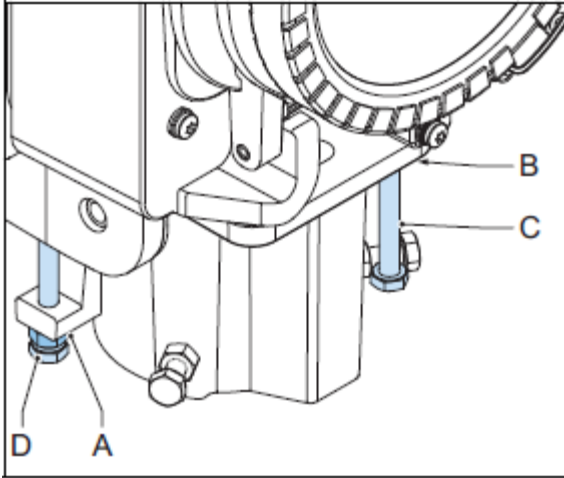

**Leveling procedure of the fixture**

1. Move the fixture until it is approximately level and hold it there. Examine the spirit level (A).
2. Turn the alignment tool 90 degrees.
3. Move the fixture until it is approximately level and hold it there. Examine the spirit level (A).

**Figure 9: Light leveling**

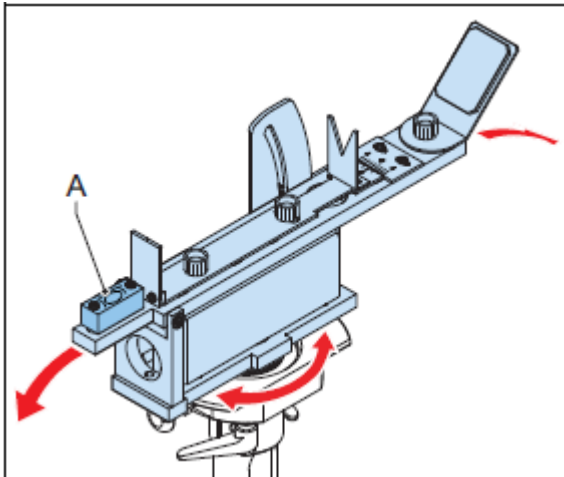

**Alignment of the fixture in azimuth - part 1**

1. From the top down, look into the mirror (A) and turn the fixture until it aligns with the reference mark (B).
2. Hold the fixture in this position.
3. Examine again if the fixture is level.

**Figure 10: Light alignment in azimuth**

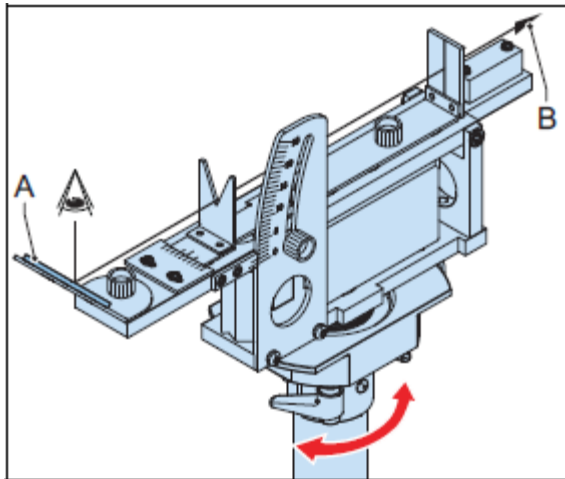

**Alignment of the fixture in azimuth - part 2**

1. Tighten the fixation screws progressively to the correct torque

**i Note**  
Refer to the [Screws Overview](#) section.

2. Tighten the lock nuts (B).

**i Note**  
Refer to the [Screws Overview](#) section.

3. If the alignment tool is turned 90, 180 or 270 degrees from the centerline, turn the alignment tool back to the centerline.

**Figure 11: Light elevation adjustment - part 1**

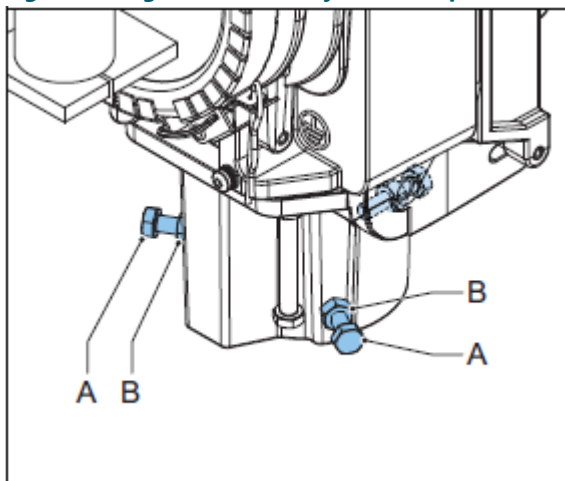

**Adjust the elevation of the fixture**

1. Turn the elevation screw (A) to tilt the fixture until the spirit level (B) show that the alignment tool is level. Make sure that the alignment tool is also level when you turn it 90 degrees.

**Fast path**

The elevation screw must touch the central body (C).

2. Turn the elevation screw (D) until it touches the central body.

3. Tighten the elevation screws progressively to the correct torque.



**Note**

Refer to the [Screws Overview](#) section.

---

4. Examine if the spirit levels show that the alignment tool is level.
  5. If not, do the previous steps again and adjust the elevation of the fixture.
  6. Tighten the lock nuts (E and F).
- 



**Note**

Refer to the [Screws Overview](#) section.

---

**Figure 12: Light elevation adjustment - part 2**

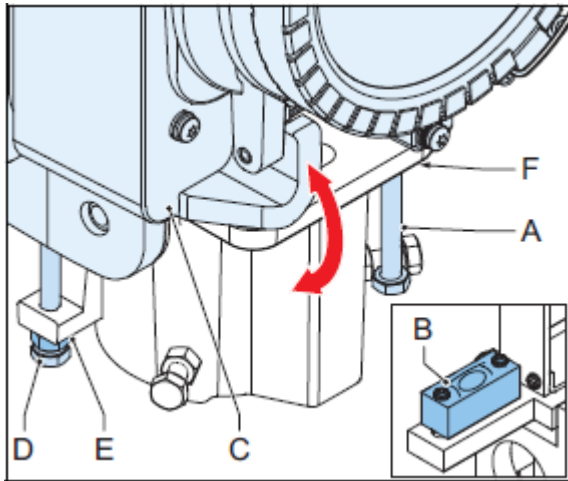

## 4.6 Aligning the Fixture with the Electronic Alignment Tool

A digital protractor is installed on the electronic alignment tool to read the elevation of the fixture. See the manual of the digital protractor on information how to do this.

If the mast is installed correctly, the tilting axis is perpendicular to the centerline. The front and back surfaces of the fixture are fully horizontal when the mast is tilted over 90 degrees.



### Alignment of the fixture in azimuth, for a fixture without toe-in

1. Lower the mast.
2. Use a spirit level to make sure that the back surface (A) of the fixture is fully horizontal.
3. Tighten the fixation screws (B) progressively to the correct torque.

**i Note**  
Refer to the [Screws Overview](#) section.

4. Tighten the lock nuts (C).

**i Note**  
Refer to the [Screws Overview](#) section.

**Figure 13: Light alignment in azimuth, without toe-in**

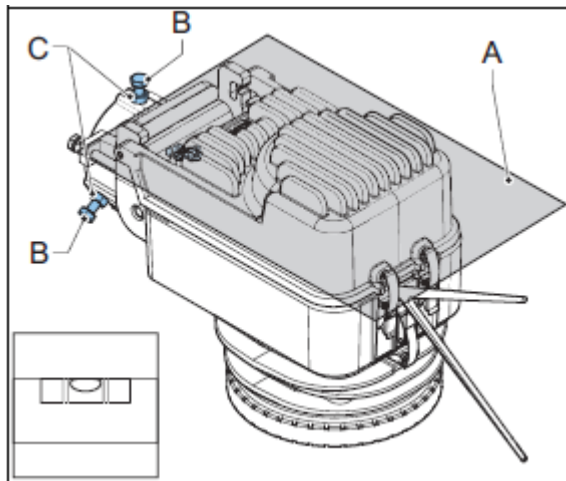

### Alignment of the fixture in azimuth, for a fixture with toe-in

1. Align the fixture in azimuth for a fixture without toe-in. See the B steps above.
2. Make a reference mark (A) on the fixture and on the mounting surface (B).
3. Loosen the lock nuts (C).
4. Loosen the fixation screws (D).
5. Turn the fixture to the required toe-in.

As a reference: A 2 degrees toe-in means a displacement of the reference marks of 1 mm (X), on the 60 mm diameter mounting support.

6. Tighten the lock nuts (C).



**Note**

Refer to the [Screws Overview](#) section.

**Figure 14: Light alignment in azimuth, with toe-in**

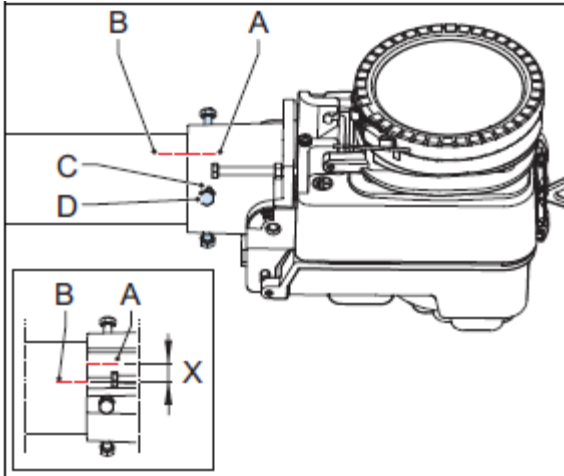

**Coarse adjustment of the the elevation of the fixture**

1. Loosen the lock nuts (A) and (B).
2. Turn the elevation screws (C) and (D) to adjust the elevation. Use the scale (E) on the fixture.
3. Make sure that both elevation screws are tightened against the the central body (F).



**Note**

Refer to the [Screws Overview](#) section.

4. Tighten the lock nuts.



**Note**

Refer to the [Screws Overview](#) section.

**Figure 15: Coarse adjustment**

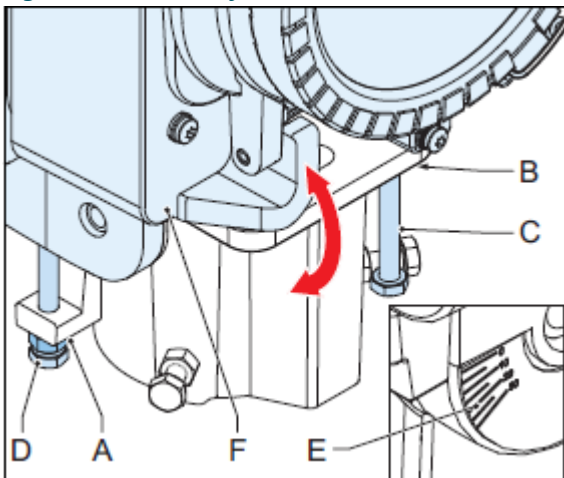

## Installation the alignment tool

1. Install the alignment tool (A) over the cooling fin (B) of the optical cartridge.
2. Make sure that the two lower hooks (C) lock the alignment tool on the optical cartridge.
3. Tighten the wing screws (D).

**Figure 16: Alignment tool adjustment - part 1**

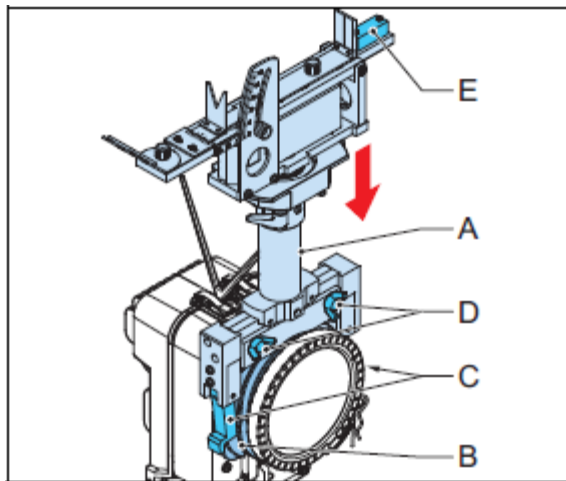

## Elevation measurement

1. Raise the mast.
2. Operate the digital protractor to measure the elevation.
3. Lower the mast.
4. Read the elevation on the digital protractor.
5. Calculate the necessary adjustment between the current elevation and the required elevation.
6. If an adjustment is necessary, adjust the elevation of the fixture.

## Adjustment of the elevation of the fixture

1. Loosen the lock nuts (A) and (B).
2. Turn the elevation screws (C) and (D) to adjust the elevation.
3. Make sure that both elevation screws are tightened against the the central body (E).



### Note

Refer to the [Screws Overview](#) section.

4. Tighten the lock nuts.



**Note**

Refer to the [Screws Overview](#) section.

5. Measure the elevation.

**Figure 17: Alignment tool adjustment - part 2**

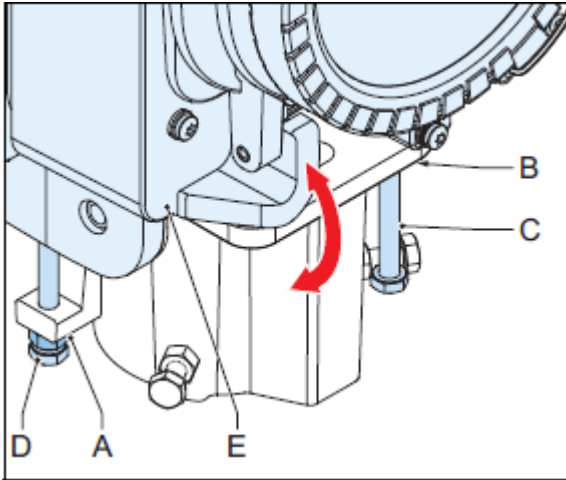

## 4.7 Removing the Alignment Tool

1. Loosen the wing screws (A).
2. Pull the lower hooks (B) to unlock the alignment tool.
3. Remove the alignment tool (C).

**Figure 18: Alignment tool removal**

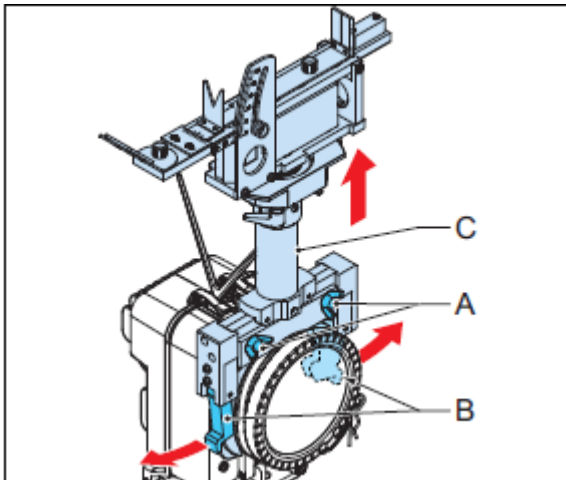

---

## 5.0 Operation

### 5.1 IQ function load (option)

With IQ enabled an additional capacity of 12 W need to be added to the transformer calculations for the powerline communication of the ILCMS. This has to be available for the communication to pass through without saturating the transformer (this power is not used and should not be included in the CCR calculation).



#### CAUTION

RELIANCE IQ is not to be connected to transformers smaller than 65 W.

---

### 5.2 2A-system

When dimensioning the isolation transformer size for a 2A-system, that is a series circuit with RELIANCE IQ 2A which is only supposed to run at 2A, it is important to know that the regular method by adding up the total wattage on the isolation transformer secondary side, cannot be used. This is because a standard isolation transformer 6.6A/6.6A is marked with a maximum wattage running at 6.6A. According to the Lenz Law of Induction, the dimensioning property of a transformer is the total voltage, and not the wattage, of the secondary side of the transformer in a 50/60Hz series circuit system.

The consequence in a 2A-system is the wattage marked on a 6.6A/6.6A isolation transformer must generally be multiplied by 3.3 (6.6/2) to find the total wattage which can be supplied from the transformer without saturating.



#### NOTICE



The same dimensioning method must be used for a CCR, as the transformer kVA-size marked on a CCR is normally calculated at 6.6A, not at 2A. There are also more constraints to consider such as spare capacity. For more information, contact ADB SAFEGATE for a complete CCR dimensioning procedure.

---



## 6.0 Troubleshooting

**Table 1: Troubleshooting guide**

Problem	Possible cause	Corrective action
No light output or the light flickers	The LED MCPCB has a malfunction.	Replace the Optical Cartridge.
	The connection to the series circuit has a malfunction.	Examine the electrical connection, the cable and the receptacles.
	The input power has a malfunction.	<ul style="list-style-type: none"> <li>• Disconnect the plug from the secondary connection.</li> <li>• Test the series circuit with a spare fixture.</li> <li>• If the light is ok, replace the Optical Cartridge.</li> </ul>
		<p> <b>Note</b> Refer to the <a href="#">Complete Optical Cartridge</a> section.</p>
		<ul style="list-style-type: none"> <li>• If the light is not ok, adjust the input power.</li> <li>• Troubleshoot the series circuit.</li> </ul>
	Connection of the electronic cartridge to the LED MCPCB has a malfunction.	<ul style="list-style-type: none"> <li>• Open the Optical Cartridge.</li> </ul>
		<p> <b>Note</b> Refer to the <a href="#">Complete Optical Cartridge</a> section.</p>
		<ul style="list-style-type: none"> <li>• Check the electrical connection between the LED MCPCB and PCB in the Electronic Cartridge.</li> </ul>
	The electronic cartridge has a malfunction	Replace the Electronic Cartridge.
		<p> <b>Note</b> Refer to the <a href="#">Complete Electronic Cartridge</a> section.</p>
Light output too low	The optical cover is dirty.	Clean the Optical Cover.
	The optical cover is defective.	Replace the Optical Cover.
	The LED MCPCB has a malfunction.	Replace the Optical Cartridge.





## 7.0 Maintenance

Maintenance personnel must refer to the maintenance procedure described in the ICAO Airport Services Manual, Part 9, Airport maintenance practices and in FAA Advisory Circular AC150/5340-26.



### WARNING



Do not carry out any action on the fixture unless you have read and understood all the information in the [Safety](#) chapter.







### DANGER

Make sure that the power to the series circuit is OFF when you carry out maintenance.

## 7.1 Basic Maintenance Program

Frequency	Check	Action
Daily	For low light output according to ICAO annex 14	<ul style="list-style-type: none"> <li>• If the Optical Cover is dirty, clean the optical cover.</li> <li>• If the Optical Cover is not dirty,               <ul style="list-style-type: none"> <li>• replace the complete Optical Cartridge.</li> </ul> </li> </ul>
		<div style="border: 1px solid black; padding: 5px; margin-bottom: 10px;">  <b>Note</b>            Refer to the <a href="#">Complete Optical Cartridge</a> section.         </div> <ul style="list-style-type: none"> <li>• and replace the faulty component in the workshop.</li> </ul>
Weekly	For contamination	Clean the fixture.
Monthly	Visually for condensation on inner side of the optical cover (presence of moisture or water) Condensation is an acceptable phenomenon, as long as it disappears when the equipment is in use	Turn on the fixture for 30 minutes. In case the condensation has not disappeared: <ul style="list-style-type: none"> <li>• Remove the Optical Cover.</li> <li>• Clean and dry the Optical Cover.</li> <li>• Replace the Optical Cover gaskets.</li> <li>• Install the dry Optical Cover.</li> </ul>
	For failed fixture	<ul style="list-style-type: none"> <li>• Replace the Optical Cartridge.</li> </ul>
		<div style="border: 1px solid black; padding: 5px; margin-bottom: 10px;">  <b>Note</b>            Refer to the <a href="#">Complete Optical Cartridge</a> section.         </div> <ul style="list-style-type: none"> <li>• and replace the faulty component in the workshop.</li> <li>• If the fixture still fails, replace the Electronic Cartridge.</li> </ul>
		<div style="border: 1px solid black; padding: 5px;">  <b>Note</b>            Refer to the <a href="#">Complete Optical Cartridge</a> section.         </div>

Frequency	Check	Action
Semi-annually	For presence of water at the inside of the fixture	<ul style="list-style-type: none"> <li>Remove the Optical Cover.</li> <li>Dry and clean the Optical Cover.</li> <li>Replace the Optical Cover gaskets.</li> <li>Install the dry Optical Cover.</li> </ul>
	For watertightness	<ul style="list-style-type: none"> <li>Replace gaskets for Optical and Electronic Cartridges.</li> </ul>
	For correct alignment and if the fixture is level.	Adjust the alignment or level the fixture.
		 <b>Note</b> Refer to the <a href="#">Installation</a> chapter.
	For damaged paint	<ul style="list-style-type: none"> <li>Clean the fixture.</li> <li>Paint the fixture again.</li> </ul>
Annually	For cracks, corrosion or short circuit	Clean the fixture and replace faulty or corroded parts.
	 <b>Note</b> Refer to the <a href="#">Complete Optical Cartridge</a> section.	
	For dirty contacts	<ul style="list-style-type: none"> <li>Make sure that the power is OFF.</li> <li>Clean the contact.</li> </ul>
	For loose connections	Tighten or repair the connection.
After snow removal	For damaged fixture	<ul style="list-style-type: none"> <li>Remove any debris or left over parts.</li> <li>Install a new fixture.</li> </ul>
		 <b>Note</b> Refer to the <a href="#">Installation</a> chapter.
		<ul style="list-style-type: none"> <li>Use a power broom to remove the snow near the fixture, if practical.</li> <li>Follow the recommended snow removal techniques described in FAA AC 150/5200-23 to avoid or at least to reduce damage to the fixture.</li> </ul>

 **NOTICE**  
Except for the complete replacement of the fixture, an electronic cartridge or an optical cartridge, all replacements must be done in the workshop.

## 7.2 Workshop Maintenance

 **Note**  
Refer to the [Components](#) section for instructions on how to correctly replace parts.

## 7.2.1 Complete Electronic Cartridge

The replacement of the complete electronic cartridge can be done in the field.

### Parts

- Electronic cartridge



### Note

Refer to [Components](#) section.

### Removal

1. Unscrew the two M8×35 bolts .
2. Open the electronic cartridge (B).
3. Disconnect:
  - the cables to the LED MCPCB (C)
  - the power cables (D)
  - the earthing connection (E)
4. Remove the electronic cartridge.
5. Remove the gasket (F).
6. Dispose of the gasket.

**Figure 19: Electronic cartridge removal**

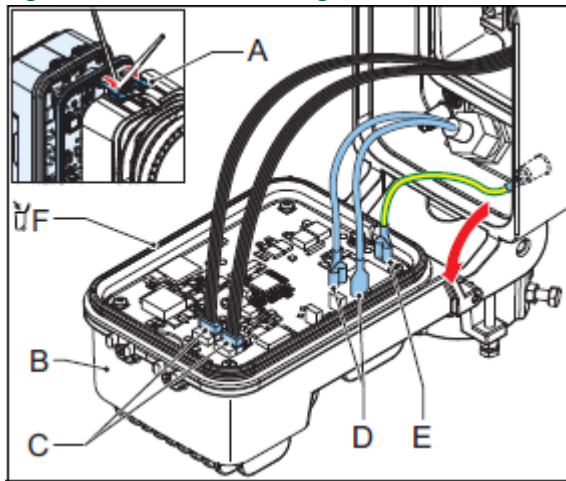

## Installation

1. Install:
  - a. the new gasket
  - b. the new electronic cartridge
2. Connect the cables to the PCB of the electronic cartridge:
  - a. Fast-on connectors (A) to the connector with label 'INPUT'.
  - b. Connector from the optical cartridge (B) to the connectors labeled 'LED A' and 'LED B'. For version with one cable connect to the connector labeled 'LED A'.
  - c. Earthing connection (C) to the connector labeled 'PE'.

**Figure 20: Electronic cartridge installation**

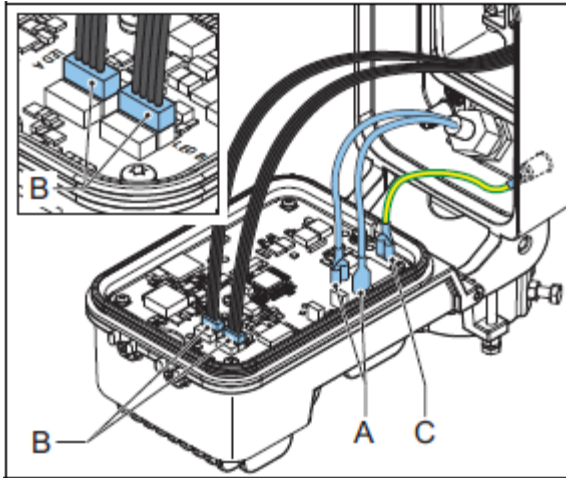

---

### Important

Make sure to connect the electronic cartridge correctly, if not it may cause failure of the fixture.

---

3. Close the electronic cartridge.
- 



### NOTICE

Make sure that no cables caught between the cartridge and the central body.

---

4. Hand tighten the two (M8×35) bolts, then tighten until the 8 Nm torque is reached.

## 7.2.2 Complete Optical Cartridge

The replacement of the complete optical cartridge can be done in the field.

### Parts

- Optical cartridge



### Note

Refer to [Components](#) section.

### Removal

1. Unscrew the two M8×35 bolts.
2. Open the optical cartridge (B).
3. Disconnect:
  - a. the cables to the LED MCPCB (C) from the electronic cartridge
  - b. the earthing connection (D)
4. Remove the optical cartridge.
5. Remove the gasket (E).
6. Dispose of the gasket.

**Figure 21: Optical cartridge removal**

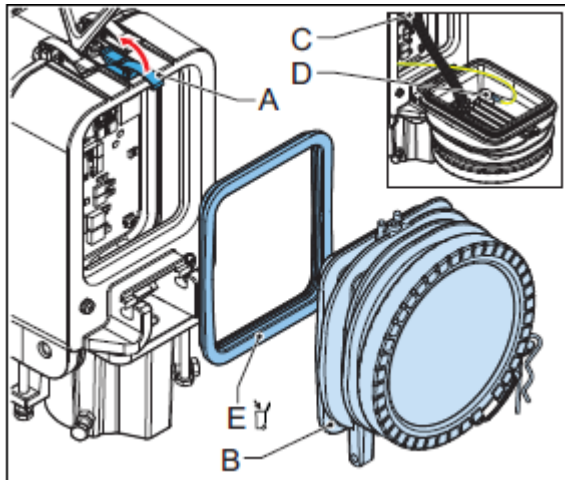

## Installation

1. Install:
  - a. the new gasket
  - b. the new optical cartridge
2. Connect the cables from the LED MCPCB (A) to the electronic cartridge to the connectors labeled 'LED A' and 'LED B'.

**Figure 22: Optical cartridge installation**

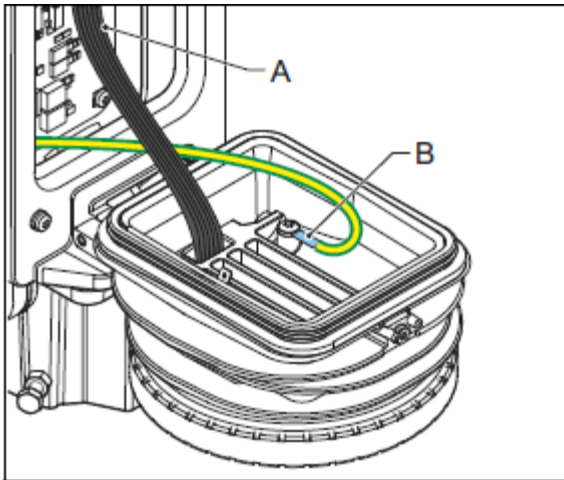

---

### Important

Make sure to connect the electronic cartridge correctly, if not it may cause failure of the fixture.

---



### NOTICE

For versions of the fixture with only one cable, connect it to the connector labeled 'LED A'.

---

3. Connect the earthing connections (B).
  4. Close the optical cartridge.
- 



### NOTICE

Make sure that there are no cables caught between the cartridge and the central body.

---

5. Hand tighten the two (M8×35) bolts, then tighten until the 8 Nm torque is reached.

## 7.2.3 Bird Deterrent

### Parts

- Bird deterrent kit



### Note

Refer to [Components](#) section for the part numbers.

### Removal

1. Remove the screw and washer (A).
2. Remove the bird deterrent (B).

**Figure 23: Bird deterrent removal**

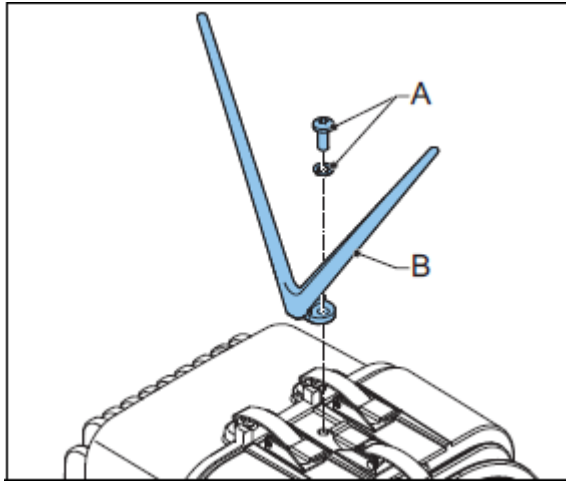

### Installation

1. Install the new bird deterrent.
2. Tighten the screws until the 2.5 Nm torque is reached.



### Note

Refer to [Screws Overview](#) section.

## 7.2.4 Latch Replacement with the Block

### Parts

- Replace the latch with the closing block kit



### Note

Refer to [Components](#) section for the part numbers.

---

### Removal of the latch

If the fixture has the latch closing system, remove the three latches.

1. Open the latch (A).
2. Remove the screws (B).
3. Remove the latches (done three times).
4. Remove the screw and washer (C).

**Figure 24: Latch removal**

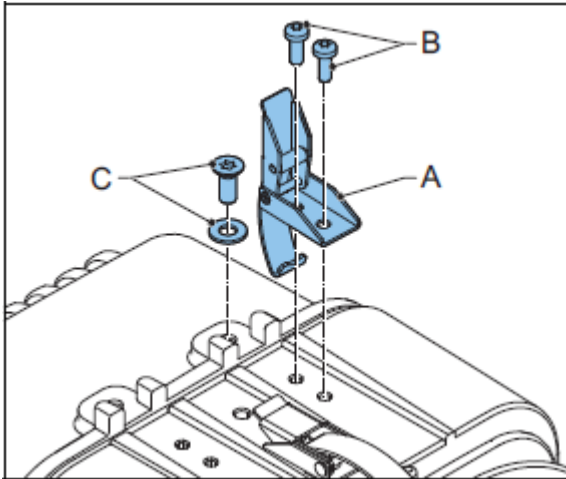

### Installation or replacement of the block

If the fixture has the block closing system, remove the block system.

**Figure 25: Block installation and replacement - part 1**

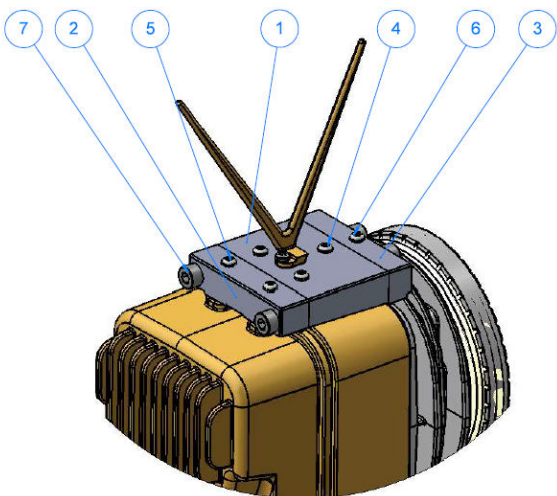



## Installation

1. Open the bolts (7).
2. Remove the screws (5) and the closing block from the power cartridge.
3. Remove the screws (6) and the closing block from the optical cartridge.
4. Remove the screws (4) and the closing block from the middle part.
5. Mount fixture closing block power cover (4072.68.940) on the power cover with two (M4×30) screws (7100.10.530) at 2.5 Nm.

**Figure 26: Block installation and replacement - part 2**

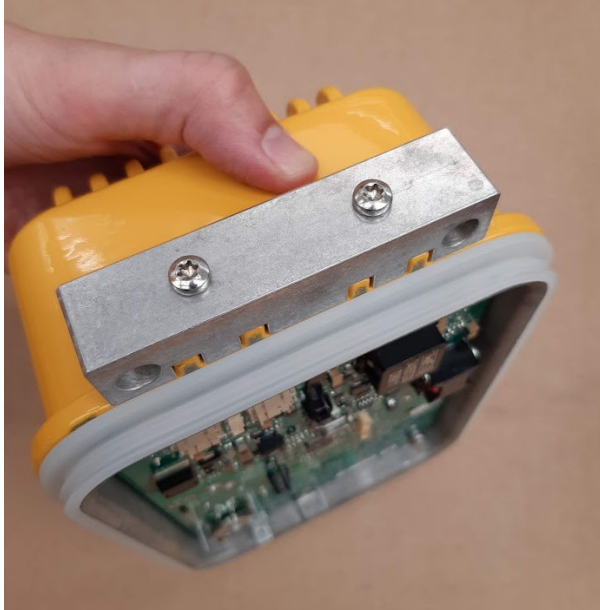

6. Mount fixture closing block optical cartridge (4072.68.950) on the optical cartridge with one (M4×35) bolt (7100.10.540) at 2.5 Nm.

**Figure 27: Block installation and replacement - part 3**



7. Mount fixture closing block rotation body (4072.68.930) on the rotation body with three (M3×30) bolts (7100.10.520) at 1.3 Nm.

**Figure 28: Block installation and replacement - part 4**

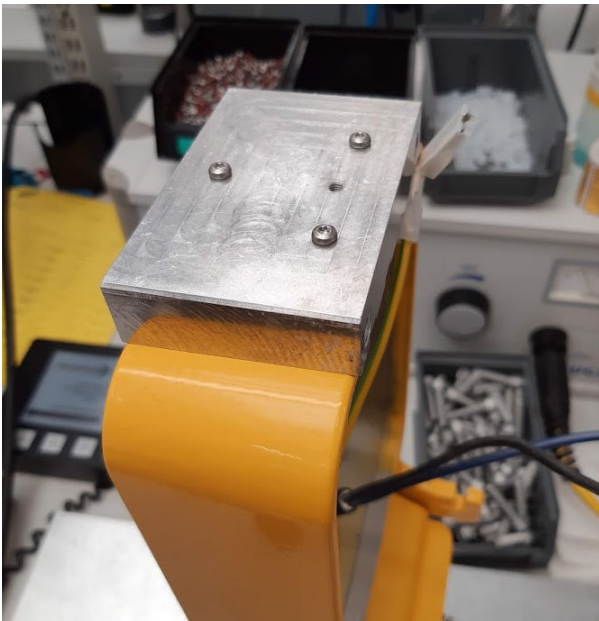

8. Replace electronic cartridge gasket and the optical cartridge gasket (1406.00.330, 20+20 pc).
9. Close the light by screwing the four (M8×35) bolts (7113.21.600) at 8 Nm.

**i NOTICE**

Screw in both bolts by hand, then gradually tighten each side until the 8 Nm torque is reached.

**Figure 29: Block installation and replacement - part 5**

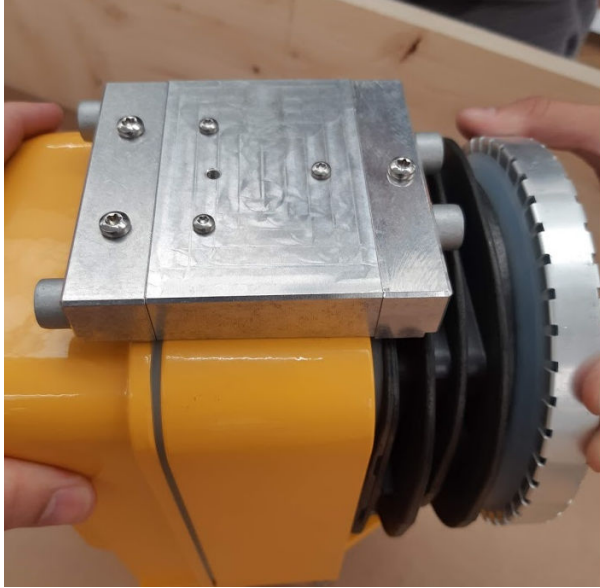

### 7.2.5 Fuse Resistor (Monitoring Option)

Parts:

- Fuse resistor kit.

**i Note**

Refer to [Components](#) section for further info.

Tools:

- Pliers

#### Disassemble

1. Disassemble the electronic cartridge. See [Complete Electronic Cartridge](#) .
2. Pull the legs of the fuse resistor (A) and remove it from the sockets.
3. Dispose of the fuse resistor.

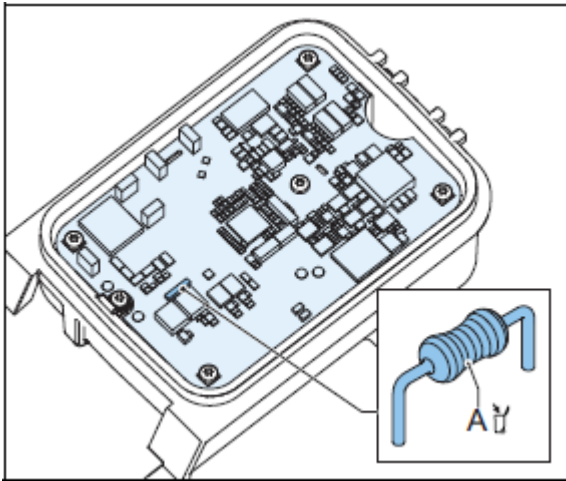

### Assemble

1. Insert the legs of the new fuse resistor in the sockets.
2. Assemble the electronic cartridge. See [Complete Electronic Cartridge](#) .

## 7.3 Fixture Operation Test

### Tools

- FAA or IEC series isolation transformer, powered from a FAA or IEC constant current regulator
1. Connect the fixture directly to the transformer. Do not use a remote communication unit between the fixture and the transformer.
  2. Set the step of the constant current generator to 6.6 A.
  3. Check if the light works properly for 10 seconds.
  4. Turn OFF the constant current generator.
  5. Troubleshoot, if the fixture did not work or has switched off before the end of the test time.



### Note

Refer to the [Troubleshooting](#) section.

---

## 8.0 Spare Parts

### 8.1 Ordering Code LEAP

The illustration below clarifies the structure of the ordering code for the RELIANCE LEAP type.

#### Ordering Code

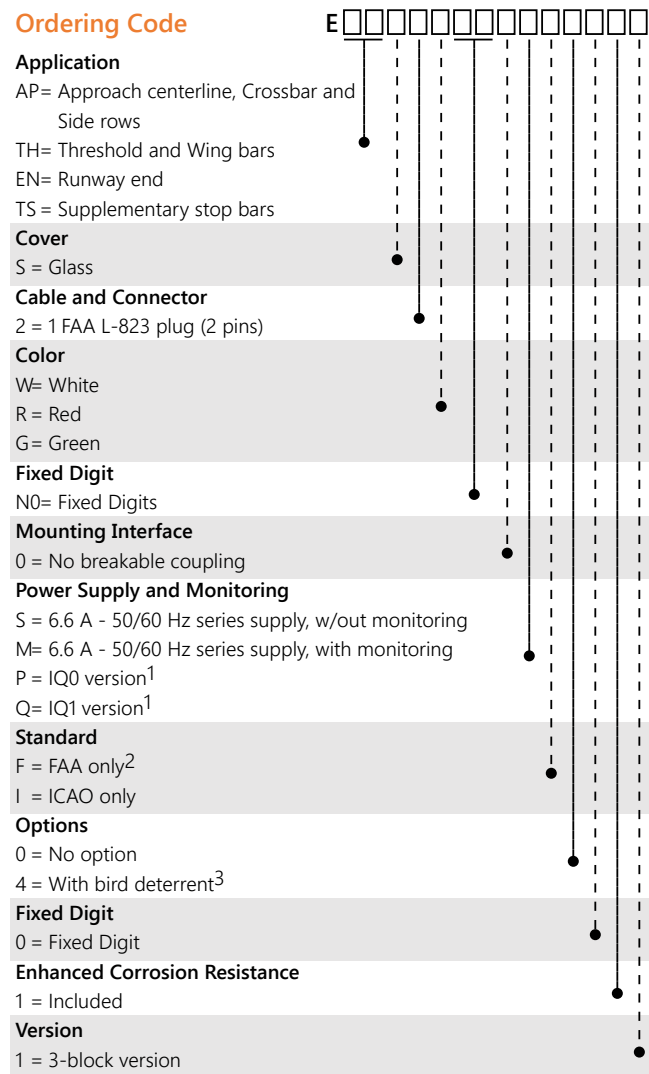

#### Notes

- 1 The IQ functionality allows control and monitoring of the fixture. IQ1 fixtures are pre-configured for the specific position at delivery. This function is disabled in IQ0 fixtures but could be enabled later.
- 2 For all EAP, ETH, and EEN lights, use I.
- 3 Not defined by FAA, hence not ETL certified.

## 8.2 Components

	Components	Versions	Article number	Packing <sup>1</sup>
A	Optical cartridge (including front glass, optical block, MCPCB and cartridge assembled)	Optical cartridge, 16 White LEDs, ICAO Approach centerline & crossbar	SP012861	Per 1
		Optical cartridge, 8 Red LEDs, ICAO Siderow	SP012862	Per 1
		Optical cartridge, 8 Green LEDs, ICAO Threshold & Threshold Wingbar	SP012863	Per 1
		Optical cartridge, 16 Green LEDs, MOS Threshold & Threshold Wingbar	SP012864	Per 1
		Optical cartridge, 8 Red LEDs, ICAO Runway End	SP012865	Per 1
		Optical cartridge, 4 Red LEDs, ICAO Stopbar Straight	SP012866	Per 1
		Optical cartridge, 4 Red LEDs, ICAO Stopbar Curved	SP012938	Per 1
		Optical cartridge, 8 Green LEDs, FAA Threshold (L862E)	SP012867	Per 1
		Optical cartridge, 8 Red LEDs, FAA Runway End (L862E)	SP012868	Per 1
		Optical cartridge, 8 Red LEDs, FAA Stopbar (L862S)	SP012869	Per 1
B	Optical cover	For all applications except FAA L-862S stop bar	1406.00.230	Per 5
		Optical cover for FAA L-862S stop bar	SP1408.20.201	Per 5
C	Optical cover gasket kit		1406.00.240	Per 20 U-shaped and 20 L-shaped gaskets
D	Clamp band for the optical cover (including the safety pin)		1406.00.250	Per 5
E	Electronic cartridge	No monitoring option (complete with PCB, gasket, spring pins and screws for the latches)	1406.00.450	Per 1
		With monitoring option (complete with PCB, gasket, spring pins and screws for the latches)	1406.00.460	Per 1
		IQ Option (complete with PCB, gasket, spring pins and screws for the latches)	1406.00.470	Per 1
F	Cartridge gasket kit (with optical cartridge and electronic cartridge gaskets)		1406.00.330	Per 20 U-shaped and 20 L-shaped gaskets for the optical cartridge and 20 gaskets for the electronic cartridge
G	LED supply cable		1406.00.340	Per 20
H	Cable lead with plug, for ground mounting (including two fast-on connectors)		1406.00.350	Per 5
I	Earthing kit (with all wires, screws, washers and tab connectors)		1406.00.360	Per 10
J	Cable gland		1406.00.370	Per 5
K	Fixation screw kit (including M6×25 screws, M6×60 screws, M6 nuts)		1406.00.390	Per 1 set for a complete fixture
		Fixation screw kit (including M8×25 screws, M8×45 screws, M8 nuts)	1406.00.395	Per 1 set for a complete fixture
L	Bird deterrent kit		1406.00.400	Per 5
M	Fuse resistor kit, for monitoring option		6132.00.250	Per 20
N	Closing Block Kit (included three blocks, M3 and M4 screws and bolts) <sup>2</sup>		1406.00.501	Per 1

### Notes

<sup>1</sup> Example: If you order 1× article number 1406.00.370, you will receive 5 cable glands.

<sup>2</sup> Gaskets for the optical and electronic cartridges needs to be ordered separately.

## 8.3 Accessories



### Note

These parts can be bought separately.

	Details	Article number
A	Standard alignment tool	1570.05.511
B	Electronic alignment tool	1570.05.521

## 8.4 Screws Overview

Screw type	Name	Quantity on a fixture	Torque (Nm)
M4×14	Optical block screws	4	0.7
M4×10	MCPCB screws	4	2.5
M6×25	Fixation screws	3	8
M8×25	Fixation screws <sup>1</sup>	3	8
M6×60	Elevation screw <sup>1</sup>	1	3.5
M6×40	Elevation screw <sup>1</sup>	1	3.5
M8×45	Elevation screws <sup>1</sup>	2	3.5
M4×14	Bird deterrent screw	1	2.5
M3×30	Rotation body closing block screws	3	1.3
M4×30	Power cartridge closing block screws	2	2.5
M4×35	Optical cartridge closing block screw	1	2.5
M8×30	Closing block bolts	4	8.0

### Notes

<sup>1</sup> The torque for the lock nut has the same value as the screw.





## Appendix A: POWER TABLE

### RELIANCE LEAP Fixture – Power Table

Fixture type	Fixture load	Isolation transformer			CCR load
		Rating	Loss	Efficiency	
EAPxxW - white approach	49 VA	65 W	9 VA	0.85	58 VA
EAPxxR - red approach	25 VA	45 W	4 VA	0.85	29 VA
ETHxxG - green threshold	35 VA	45 W	6 VA	0.85	41 VA
EENxxR - red runway end	18 VA	45 W	3 VA	0.85	21 VA
ETSxxR - red stop bar	13 VA	45 W	2 VA	0.85	15 VA



#### Note

- Extra losses in secondary cables or due to extra equipment (e.g. ILCMS remotes) are not included in above table; these extra losses will result in a higher required size of isolation transformers.
- Extra losses in primary cables are not included in above table; these extra losses will result in a higher required CCR load.
- Efficiency of the secondary transformer depends on the supplier of secondary transformers.

For IQ fixtures:

- The minimum dimension for the isolation transformer is 65 W
- The isolation transformer must have an extra 12 VA available on top of the load for communication bandwidth

For fail-open fixtures:

- The maximum dimension for the isolation transformer is 150 W

For a 2A power system, refer to the 2A power system description for further explanation:

- The 2A power system requires the isolation transformer to be 3.3 times the rating for an IQ-fixture on a 6.6A constant current power system with a minimum of 200 W
- The regulator load is correct as indicated in the table, but the size of the regulator must be 3.3 times the load that is needed

For more information about the product, including manuals and certifications, please see our Product Center on the ADB SAFEGATE website: [www.adbsafegate.com](http://www.adbsafegate.com).



## Appendix B: CABLE LOSS

The cable resistance R (Ohms) for 1 conductor is calculated with following formula:

- $R \text{ (Ohms)} = \text{resistivity of material (Ohm m)} * \text{Length (m)} / \text{cross sectional area (m}^2\text{)}$
- for copper conductors the resistivity is  $1.72 \cdot 10^{-8} \text{ (m}^2\text{)}$

For example for 1km 2.5 mm<sup>2</sup> copper cond., the resistance R is calculated like this:

$$1.72 \cdot 10^{-8} * 1000 / 2.5 \cdot 10^{-6} \text{ m}^2 = 6.88 \text{ Ohms}$$

The loss (Watt) is then  $R * I^2$  or  $6.88 \text{ Ohms} * 6.6^2 \text{ A}^2 = 299.69 \text{ W} / \text{km}$  or  $0.299 \text{ W} / \text{m}$ .

The loss (Watt) for a secondary cable with 2 conductors is thus  $2 * 0.299 = 0,599$  or  $0,6 \text{ W} / \text{m}$ .

As such we can calculate:

- for a 2.5 mm<sup>2</sup> Cu-wire (2 conductors) :  $0.6 \text{ W} / \text{m}$
- for a 4 mm<sup>2</sup> Cu-wire (2 conductors) :  $0.4 \text{ W} / \text{m}$
- for a 6 mm<sup>2</sup> Cu-wire (1 conductor):  $0,12 \text{ W/m}$

The cable between the isolation transformer and the lamp adds losses that cannot be ignored when dimensioning the circuits and selecting rating for secondary transformers and regulators.



### NOTICE

Secondary cable lengths should not exceed 100 m.

For a secondary cable of e. g. 20 m of 2.5 mm<sup>2</sup> CU-wire,  $20 \text{ m} * 0.6 \text{ W} / \text{m} = 12 \text{ W}$  equals the additional loss to be taken into account.

For a primary cable of e. g. 100 m of 6mm<sup>2</sup> CU-wire,  $100 \text{ m} * 0,12 \text{ W} / \text{m} = 12 \text{ W}$  equals the additional loss to be taken into account.



## Appendix C: SUPPORT

Our experienced engineers are available for support and service at all times, 24 hour/7 days a week. They are part of a dynamic organization making sure the entire ADB SAFEGATE is committed to minimal disturbance for airport operations.

### ADB SAFEGATE Support

#### Live Technical Support - Americas

If at any time you have a question or concern about your product, just contact ADB SAFEGATE's technical service department. Trained in all areas of system issues, troubleshooting, quality control and technical assistance, our highly experienced Technical support specialists are available 24 hours a day, seven days a week to provide assistance over the phone.

ADB SAFEGATE **Americas Technical Service & Support (US & Canada): +1-800-545-4157**

**ADB SAFEGATE Americas Technical Service & Support (International): +1-614-861-1304**

During regular business hours, you can also Chat with a Service Technician. We look forward to working with you!

#### Before You Call

When you have an airfield lighting or system control system problem it is our goal to support airfield maintenance staff as quickly as possible. To support this effort we ask that you have the following information ready before calling.

- The *airport code*
- If not with an airport, then company name (prefer customer id number)
- Contact phone number and email address
- Product with part number preferable or product number
- Have you reviewed the product's manual and troubleshooting guide
- Do you have a *True RMS* meter available (and any other necessary tools)
- Be located with the product ready to troubleshoot

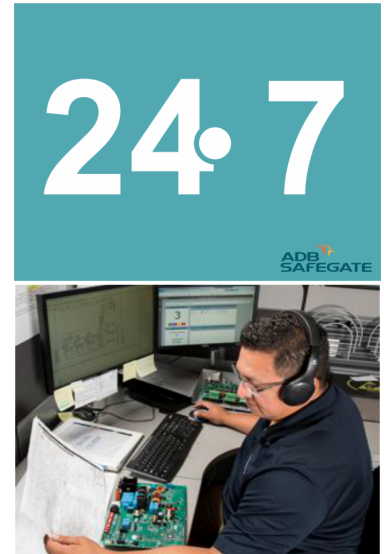

#### Note

For more information, see [www.adbsafegate.com](http://www.adbsafegate.com), or contact ADB SAFEGATE Support via email at [support@adbsafegate.com](mailto:support@adbsafegate.com) or

Brussels: +32 2 722 17 11

Rest of Europe: +46 (0) 40 699 17 40

Americas: +1 614 861 1304. Press 3 for technical service or press 4 for sales support.

China: +86 (10) 8476 0106

### C.1 ADB SAFEGATE Website

The ADB SAFEGATE website, [www.adbsafegate.com](http://www.adbsafegate.com), offers information regarding our airport solutions, products, company, news, links, downloads, references, contacts and more.

## C.2 Recycling

### C.2.1 Local Authority Recycling

The disposal of ADB SAFEGATE products is to be made at an applicable collection point for the recycling of electrical and electronic equipment. The correct disposal of equipment prevents any potential negative consequences for the environment and human health, which could otherwise be caused by inappropriate waste handling. The recycling of materials helps to conserve natural resources. For more detailed information about recycling of products, contact your local authority city office.

### C.2.2 ADB SAFEGATE Recycling

ADB SAFEGATE is fully committed to environmentally-conscious manufacturing with strict monitoring of our own processes as well as supplier components and sub-contractor operations. ADB SAFEGATE offers a recycling program for our products to all customers worldwide, whether or not the products were sold within the EU.

ADB SAFEGATE products and/or specific electrical and electronic component parts which are fully removed/separated from any customer equipment and returned will be accepted for our recycling program.

All items returned must be clearly labeled as follows:

- For *ROHS/WEEE* Recycling
- Sender contact information (Name, Business Address, Phone number).
- Main Unit Serial Number.

ADB SAFEGATE will continue to monitor and update according for any future requirements for *EU directives* as and when *EU member states* implement new *regulations* and or *amendments*. It is our aim to maintain our *compliance plan* and assist our customers.

## Company Addresses

ADB SAFEGATE	ADB SAFEGATE, Belgium: Leuvensesteenweg 585, B-1930 Zaventem Belgium
Contact: Tel.: +32 2 722 17 11, Fax: +32 2 722 17 64	Email: <a href="mailto:marketing@adbsafegate.com">marketing@adbsafegate.com</a> Internet: <a href="http://www.adbsafegate.com">www.adbsafegate.com</a>
Americas LLC	ADB SAFEGATE, Americas: 977 Gahanna Parkway, Columbus, OH 43230 USA
Contact: Tel.: +1 (614) 861 1304, Fax: +1 (614) 864 2069	Email: <a href="mailto:sales.us@adbsafegate.com">sales.us@adbsafegate.com</a> Internet: <a href="http://www.adbsafegate.com">www.adbsafegate.com</a>
ADB SAFEGATE Sweden AB	ADB SAFEGATE, Sweden: Djurhagegatan 19 SE-213 76 Malmö Sweden
Contact: Tel.: +46 (0)40 699 17 00, Fax: +46 (0)40 699 17 30	Email: <a href="mailto:marketing@adbsafegate.com">marketing@adbsafegate.com</a> Internet: <a href="http://www.adbsafegate.com">www.adbsafegate.com</a>
ADB SAFEGATE Airfield Technologies Ltd. China	ADB SAFEGATE, China: Unit 603, D Block, CAMIC International Convention Center, No 3, Hua Jia Di East road, ChaoYang district, Beijing 100102 P.R. China
Contact: Tel.: +86 (10) 8476 0106, Fax: +86 (10) 8476 0090	Email: <a href="mailto:china@safegate.com">china@safegate.com</a> Internet: <a href="http://www.adbsafegate.com">www.adbsafegate.com</a>
ADB SAFEGATE Germany GmbH	ADB SAFEGATE Germany GmbH, Mannheim: Konrad-Zuse-Ring 6, D-68163 Mannheim Germany
Contact: Tel.: +49 (621) 87 55 76-0, Fax: +49 (621) 87 55 76-55	Email: <a href="mailto:marketing@adbsafegate.com">marketing@adbsafegate.com</a> Internet: <a href="http://www.adbsafegate.com">www.adbsafegate.com</a>



## Powering Your Airport Performance from Approach to Departure

[adbsafegate.com](https://adbsafegate.com)

Copyright © ADB SAFEGATE, all rights reserved

