



L-861SE Clamp Band ERTE
Incandescent Elevated Runway Threshold/End Light, Medium-
Intensity, Clamp Band

User Manual

96A0193, Rev. K, 2020/09/10

**ADB
SAFEGATE**

A.0 Disclaimer / Standard Warranty

CE certification

The equipment listed as CE certified means that the product complies with the essential requirements concerning safety and hygiene. The European directives that have been taken into consideration in the design are available on written request to ADB SAFEGATE.

ETL certification

The equipment listed as ETL certified means that the product complies with the essential requirements concerning safety and FAA Airfield regulations. The FAA directives that have been taken into consideration in the design are available on written request to ADB SAFEGATE.

All Products Guarantee

ADB SAFEGATE will correct by repair or replacement per the applicable guarantee above, at its option, equipment or parts which fail because of mechanical, electrical or physical defects, provided that the goods have been properly handled and stored prior to installation, properly installed and properly operated after installation, and provided further that Buyer gives ADB SAFEGATE written notice of such defects after delivery of the goods to Buyer. Refer to the Safety section for more information on Material Handling Precautions and Storage precautions that must be followed.

ADB SAFEGATE reserves the right to examine goods upon which a claim is made. Said goods must be presented in the same condition as when the defect therein was discovered. ADB SAFEGATE further reserves the right to require the return of such goods to establish any claim.

ADB SAFEGATE's obligation under this guarantee is limited to making repair or replacement within a reasonable time after receipt of such written notice and does not include any other costs such as the cost of removal of defective part, installation of repaired product, labor or consequential damages of any kind, the exclusive remedy being to require such new parts to be furnished.

ADB SAFEGATE's liability under no circumstances will exceed the contract price of goods claimed to be defective. Any returns under this guarantee are to be on a transportation charges prepaid basis. For products not manufactured by, but sold by ADB SAFEGATE, warranty is limited to that extended by the original manufacturer. This is ADB SAFEGATE's sole guarantee and warranty with respect to the goods; there are no express warranties or warranties of fitness for any particular purpose or any implied warranties of fitness for any particular purpose or any implied warranties other than those made expressly herein. All such warranties being expressly disclaimed.

Standard Products Guarantee

Products of ADB SAFEGATE manufacture are guaranteed against mechanical, electrical, and physical defects (excluding lamps) which may occur during proper and normal use for a period of two years from the date of ex-works delivery, and are guaranteed to be merchantable and fit for the ordinary purposes for which such products are made.



Note

See your sales order contract for a complete warranty description.

FAA Certified product installed in the United States and purchased or funded with monies through the Airport Improvement Program (AIP) installations guarantee

ADB SAFEGATE L858 Airfield Guidance Signs are warranted against mechanical and physical defects in design or manufacture for a period of 2 years from date of installation, per FAA AC 150/5345-44 (applicable edition).

ADB SAFEGATE L858(L) Airfield Guidance Signs are warranted against electrical defects in design or manufacture of the LED or LED specific circuitry for a period of 4 years from date of installation, per FAA EB67 (applicable edition).

ADB SAFEGATE LED light fixtures (with the exception of obstruction lighting) are warranted against electrical defects in design or manufacture of the LED or LED specific circuitry for a period of 4 years from date of installation, per FAA EB67 (applicable edition).



Note

See your sales order contract for a complete warranty description.

Liability



WARNING

Use of the equipment in ways other than described in the catalog leaflet and the manual may result in personal injury, death, or property and equipment damage. Use this equipment only as described in the manual.

ADB SAFEGATE cannot be held responsible for injuries or damages resulting from non-standard, unintended uses of its equipment. The equipment is designed and intended only for the purpose described in the manual. Uses not described in the manual are considered unintended uses and may result in serious personal injury, death or property damage.

Unintended uses, includes the following actions:

- Making changes to equipment that have not been recommended or described in this manual or using parts that are not genuine ADB SAFEGATE replacement parts or accessories.
- Failing to make sure that auxiliary equipment complies with approval agency requirements, local codes, and all applicable safety standards if not in contradiction with the general rules.
- Using materials or auxiliary equipment that are inappropriate or incompatible with your ADB SAFEGATE equipment.
- Allowing unskilled personnel to perform any task on or with the equipment.

© ADB SAFEGATE BV

This manual or parts thereof may not be reproduced, stored in a retrieval system, or transmitted, in any form or by any means, electronic, mechanical, photocopying, recording, nor otherwise, without ADB SAFEGATE BV's prior written consent.

This manual could contain technical inaccuracies or typographical errors. ADB SAFEGATE BV reserves the right to revise this manual from time to time in the contents thereof without obligation of ADB SAFEGATE BV to notify any person of such revision or change. Details and values given in this manual are average values and have been compiled with care. They are not binding, however, and ADB SAFEGATE BV disclaims any liability for damages or detriments suffered as a result of reliance on the information given herein or the use of products, processes or equipment to which this manual refers. No warranty is made that the use of the information or of the products, processes or equipment to which this manual refers will not infringe any third party's patents or rights. The information given does not release the buyer from making their own experiments and tests.

TABLE OF CONTENTS

1.0 Safety	1
1.1 Safety Messages	1
1.1.1 Introduction to Safety	2
1.1.2 Intended Use	2
1.1.3 Material Handling Precautions: Storage	3
1.1.4 Maintenance Safety	3
1.1.5 Material Handling Precautions, ESD	3
1.1.6 Arc Flash and Electric Shock Hazard	4
2.0 L-861SE Clamp Band ERTE	5
2.1 About this manual	5
2.2 Introduction	5
2.3 How to work with the manual	5
3.0 Product Introduction	7
3.1 Incandescent Elevated Runway Threshold/End Light	7
3.2 Equipment and Accessories Supplied	8
3.3 Equipment Required But Not Supplied	9
4.0 Installation Introduction	11
4.1 Inspection on Arrival	11
4.1.1 Storage	11
4.1.2 Unpacking and Material Inspection	11
4.1.3 Installation Procedures	11
4.2 Installation	12
4.2.1 Placement	12
4.2.2 Base Mounting	12
4.2.3 Light Fixture Mounting	13
4.2.4 Stake Mounting	14
4.2.5 Stake Assembly	14
4.2.6 Stake Installation	15
5.0 Maintenance	17
5.1 Periodic Maintenance Schedule	17
5.2 Maintenance Procedures	17
5.3 Troubleshooting	18
5.3.1 Action Table in the Event of a System or Component Malfunction	18
6.0 Parts	19
6.1 Product Major Components	19
6.2 Illustrated Parts List or Exploded View Diagram	20
A.0 SUPPORT	23
A.1 ADB SAFEGATE Website	23
A.2 Recycling	24
A.2.1 Local Authority Recycling	24
A.2.2 ADB SAFEGATE Recycling	24

List of Figures

Figure 1: L-861SE Light Fixture Assembly	12
Figure 2: Base Mounting	13
Figure 3: Stake Mounting	15
Figure 4: ERTE Assembly (see Tables 4-7)	20

List of Tables

Table 1: Mounting Heights	7
Table 2: Required Equipment Supplied	8
Table 3: Required Equipment Not Supplied	9
Table 4: L-861SE Threshold/End Light Fixture Maintenance	17
Table 5: Product ERTE Troubleshooting Guide Table	18
Table 6: Spare Components	19
Table 7: H1R/L Inner Lens	21
Table 8: A1 and M2 Column and Head Assembly	21
Table 9: H2 Outer Lens	21
Table 10: M3 Coupling	22
Table 11: Stake Mounting and Hardware	22

1.0 Safety

Introduction to Safety

This section contains general safety instructions for installing and using ADB SAFEGATE equipment. Some safety instructions may not apply to the equipment in this manual. Task- and equipment-specific warnings are included in other sections of this manual where appropriate.

1.1 Safety Messages

HAZARD Icons used in the manual

For all HAZARD symbols in use, see the Safety section. All symbols must comply with ISO and ANSI standards.

Carefully read and observe all safety instructions in this manual, which alert you to safety hazards and conditions that may result in personal injury, death or property and equipment damage and are accompanied by the symbol shown below.



WARNING

Failure to observe a warning may result in personal injury, death or equipment damage.



DANGER - Risk of electrical shock or ARC FLASH

Disconnect equipment from line voltage. Failure to observe this warning may result in personal injury, death, or equipment damage. ARC Flash may cause blindness, severe burns or death.



WARNING - Wear personal protective equipment

Failure to observe may result in serious injury.



WARNING - Do not touch

Failure to observe this warning may result in personal injury, death, or equipment damage.



CAUTION

Failure to observe a caution may result in equipment damage.

Qualified Personnel



Important Information

The term **qualified personnel** is defined here as individuals who thoroughly understand the equipment and its safe operation, maintenance and repair. Qualified personnel are physically capable of performing the required tasks, familiar with all relevant safety rules and regulations and have been trained to safely install, operate, maintain and repair the equipment. It is the responsibility of the company operating this equipment to ensure that its personnel meet these requirements.

Always use required personal protective equipment (PPE) and follow safe electrical work practice.

1.1.1 Introduction to Safety



CAUTION

Unsafe Equipment Use

This equipment may contain electrostatic devices, hazardous voltages and sharp edges on components

- Read installation instructions in their entirety before starting installation.
- Become familiar with the general safety instructions in this section of the manual before installing, operating, maintaining or repairing this equipment.
- Read and carefully follow the instructions throughout this manual for performing specific tasks and working with specific equipment.
- Make this manual available to personnel installing, operating, maintaining or repairing this equipment.
- Follow all applicable safety procedures required by your company, industry standards and government or other regulatory agencies.
- Install all electrical connections to local code.
- Use only electrical wire of sufficient gauge and insulation to handle the rated current demand. All wiring must meet local codes.
- Route electrical wiring along a protected path. Make sure they will not be damaged by moving equipment.
- Protect components from damage, wear, and harsh environment conditions.
- Allow ample room for maintenance, panel accessibility, and cover removal.
- Protect equipment with safety devices as specified by applicable safety regulations
- If safety devices must be removed for installation, install them immediately after the work is completed and check them for proper functioning prior to returning power to the circuit.

Failure to follow this instruction can result in serious injury or equipment damage

Additional Reference Materials



Important Information

- IEC - International Standards and Conformity Assessment for all electrical, electronic and related technologies.
- IEC 60364 - Electrical Installations in Buildings.
- FAA Advisory: AC 150/5340-26 (current edition), Maintenance of Airport Visual Aid Facilities.
- Maintenance personnel must refer to the maintenance procedure described in the ICAO Airport Services Manual, Part 9.
- ANSI/NFPA 79, Electrical Standards for Metalworking Machine Tools.
- National and local electrical codes and standards.

1.1.2 Intended Use



CAUTION

Use this equipment as intended by the manufacturer

This equipment is designed to perform a specific function, do not use this equipment for other purposes

- Using this equipment in ways other than described in this manual may result in personal injury, death or property and equipment damage. Use this equipment only as described in this manual.

Failure to follow this instruction can result in serious injury or equipment damage

1.1.3 Material Handling Precautions: Storage



CAUTION

Improper Storage

Store this equipment properly

- If equipment is to be stored prior to installation, it must be protected from the weather and kept free of condensation and dust.

Failure to follow this instruction can result in equipment damage

1.1.4 Maintenance Safety



DANGER

Electric Shock Hazard

This equipment may contain electrostatic devices

- Do not operate a system that contains malfunctioning components. If a component malfunctions, turn the system OFF immediately.
- Disconnect and lock out electrical power.
- Allow only qualified personnel to make repairs. Repair or replace the malfunctioning component according to instructions provided in its manual.

Failure to follow these instructions can result in death or equipment damage

1.1.5 Material Handling Precautions, ESD



CAUTION

Electrostatic Sensitive Devices

This equipment may contain electrostatic devices

- Protect from electrostatic discharge.
- Electronic modules and components should be touched only when this is unavoidable e.g. soldering, replacement.
- Before touching any component of the cabinet you shall bring your body to the same potential as the cabinet by touching a conductive earthed part of the cabinet.
- Electronic modules or components must not be brought in contact with highly insulating materials such as plastic sheets, synthetic fiber clothing. They must be laid down on conductive surfaces.
- The tip of the soldering iron must be grounded.
- Electronic modules and components must be stored and transported in conductive packing.

Failure to follow this instruction can result in equipment damage

1.1.6 Arc Flash and Electric Shock Hazard



DANGER

Series Circuits have Hazardous Voltages

This equipment produces high voltages to maintain the specified current - Do NOT Disconnect while energized.

- Allow only qualified personnel to perform maintenance, troubleshooting, and repair tasks.
- Only persons who are properly trained and familiar with ADB SAFEGATE equipment are permitted to service this equipment.
- An open airfield current circuit is capable of generating >5000 Vac and may appear OFF to a meter.
- Never unplug a device from a constant current circuit while it is operating; Arc flash may result.
- Disconnect and lock out electrical power.
- Always use safety devices when working on this equipment.
- Follow the recommended maintenance procedures in the product manuals.
- Do not service or adjust any equipment unless another person trained in first aid and CPR is present.
- Connect all disconnected equipment ground cables and wires after servicing equipment. Ground all conductive equipment.
- Use only approved ADB SAFEGATE replacement parts. Using unapproved parts or making unapproved modifications to equipment may void agency approvals and create safety hazards.
- Check the interlock systems periodically to ensure their effectiveness.
- Do not attempt to service electrical equipment if standing water is present. Use caution when servicing electrical equipment in a high-humidity environment.
- Use tools with insulated handles when working with airfield electrical equipment.

Failure to follow these instructions can result in death or equipment damage

2.0 L-861SE Clamp Band ERTE

Incandescent Elevated Runway, Medium-Intensity, Clamp Band Threshold/End Light.

The ERTE is used to indicate a runway threshold/end. The light fixture is built to withstand jet blast while having a lamp life of 500 hours at 6.6A. The top casting holds the outer globe, which is indexed to the fixture and held in place by a continuous clamping band.

2.1 About this manual

2.2 Introduction

Provides the purpose, scope, and applicability of the technical manual.

The manual shows the information necessary to:

- Example: Install and maintain said equipment.

2.3 How to work with the manual

1. Become familiar with the structure and content.
2. Carry out the actions completely and in the given sequence.

3.0 Product Introduction

This section describes the L-861SE threshold/end light. The L-861SE threshold/end light is used to delineate the threshold/end of non-precision IFR runways.



The L-861SE light fixture consists of the following:

- A pair of inner lens doublets (3) coupled with a clear outer globe (1)
- Continuous clamping band (4)
- Inner spring clip (2) to hold two 180-degree inner lens segments
- Frangible coupling (7) that threads into a 1-1/2 12 NPT tapped hole in either a 30-inch (762-mm) stake assembly or a 12-inch-diameter L-867 base cover plate.

The cast aluminum head and base assembly can be mounted on a standard

L-867 base plate or on a steel stake. Base mounting is easier to maintain and provides added protection for the equipment. Stake-mounted lights require transformers, cables, and connectors that are designed for direct earth burial.

Refer to [Table 1](#) for mounting heights.



Note

The measurements in [Table 1](#) are taken from the grade to the top of the light fixture.

Table 1: Mounting Heights

Type	Height (in.)	Height (mm)
Standard (FAA minimum)	14	355.6
Standard	24	610
Standard (FAA maximum)	29	736.6

The L-861SE light fixture is available with bidirectional white/red, white/green, red/green, red/red, green/green, green/yellow lenses.

3.1 Incandescent Elevated Runway Threshold/End Light

Compliance with Standards

FAA: L-861SE AC 150/5345-46 (Current Edition). ETL Certified.

Uses

FAA L-861SE

- Runway threshold/end
- Non-precision IFR runways

Features

- Top casting holds the outer globe, which is indexed to the fixture and held in place by a continuous clamping band. Two prismatic inner lens segments are mounted inside on the socket mounting plate assembly.
- Light fixture is designed to withstand jet blast.
- Lamp Life: Rated at 500-1000 hours at 6.6 A. 1,000 hour rating valid on 110W lamp only.
- Four screws allow a 4° leveling adjustment of the fixture after installation.
- Fixture uses aluminum castings, stainless steel hardware, and is protected with aviation yellow gloss enamel paint.

Operating Conditions

Temperature:	-40 °F to +131 °F / -40 °C to +55 °C
Wind:	Withstands wind velocities up to 300 mph / 480 kph

Packaging

Assembled Fixtures	Dimensions of Cartons - in (cm)		Indiv. Weight
	Individual	8 Per Box	
14-inch OAH	6.5 × 6.5 × 20.5	15.5 × 23.5 × 19.5	5 lb
	(17 × 17 × 52)	(39.5 × 60 × 50)	2.3 kg
24-inch OAH	6.5 × 6.5 × 31	19.5 × 19.5 × 29	6.25 lb
	(17 × 17 × 79)	(50 × 50 × 74)	2.8 kg
30-inch OAH	6.5 × 6.5 × 37	19.5 × 19.5 × 35.5	7 lb
	(17 × 17 × 94)	(50 × 50 × 90)	3.2 kg

3.2 Equipment and Accessories Supplied

Refer to [Table 2](#) for required equipment that is supplied.

Table 2: Required Equipment Supplied

Description	Quantity
L-861SE light fixture (includes lamp, frangible coupling, and L-823 cordset)	1
Instruction manual	1 per order

3.3 Equipment Required But Not Supplied

Refer to [Table 3](#) for required equipment that is not supplied. Refer to the *Parts* section for part numbers.

Table 3: Required Equipment Not Supplied

Description	Quantity
Torque wrench, 0□200 in-lb with 3/8 socket	1
Screwdriver. #2 Phillips	1
L-867 base, 12 or 16-inches in diameter. Used only when base mounted.	1
Stake assembly (30-inch galvanized steel). Used only when stake mounted.	1
L-830 isolation transformer for series circuit.	1
Single conductor (primary) connector kit	1
Two-conductor (secondary) plug connector kit	1
Two-conductor (secondary) receptacle connector kit	1
Loctite Grade AV or equivalent	As required

4.0 Installation Introduction

This section provides instructions for installing the L-861SE threshold/end light fixture. Refer to the airport project plans and specifications for the specific installation instructions.

4.1 Inspection on Arrival

Inspect each light on arrival, note any damage and report to the carrier and your ADB representative.

4.1.1 Storage

The proper storage of the ERTE on a shelf is to leave it in the box it arrived in or place in a bin with a protective wrap to protect the glass from damage.

4.1.2 Unpacking and Material Inspection

The equipment is shipped ready for installation. Handle equipment very carefully to prevent component damage. Unpack the carton upon receipt and check the contents and their condition. Note any exterior damage to the carton that might lead to detection of equipment damage.

If you note any damage to any equipment, file a claim with the carrier immediately. The carrier may need to inspect the equipment.

4.1.3 Installation Procedures

This subsection describes procedures for assembling the L-861SE light fixture.



Note

Check the packing list with the parts list to verify that all parts are present before proceeding. Refer to the [Parts](#) section.

To assemble the parts, perform the following procedure:

1. See [Figure 1](#). Place the L-823 cordset into the column (8).
2. See [Figure 1](#). Insert the column (8) into the end of the lower casting of the head assembly (11). Secure the head to the column by tightening the Phillips head screws (7). Apply Loctite to the Phillips head screws (7) and hex head screws (10).
3. Insert the end of the column into the frangible coupling (9) and secure by tightening the hex head screw (10).



CAUTION

- Do not install lamp, inner lenses, and lens assembly until you have mounted the fixture on a stake or base plate for the L-867 base. If you do not mount the fixture first, you may twist the cordset off the socket or break the socket prongs. Refer to Base Mounting and Stake Mounting in this section.

4. Insert the lamp (5) into the socket (14). Refer to the Repair section.



CAUTION

- Touching quartz lamps with bare fingers may seriously shorten lamp life. If the lamp is accidentally touched with bare fingers, clean with a tissue moistened with isopropyl alcohol.

5. Install the inner lens segments (4) using the lens divider (3) and inner spring clip (2) against the socket plate (13).
6. Place the outer globe (1) on the base and secure by tightening the lens clamp band (6).

Figure 1: L-861SE Light Fixture Assembly

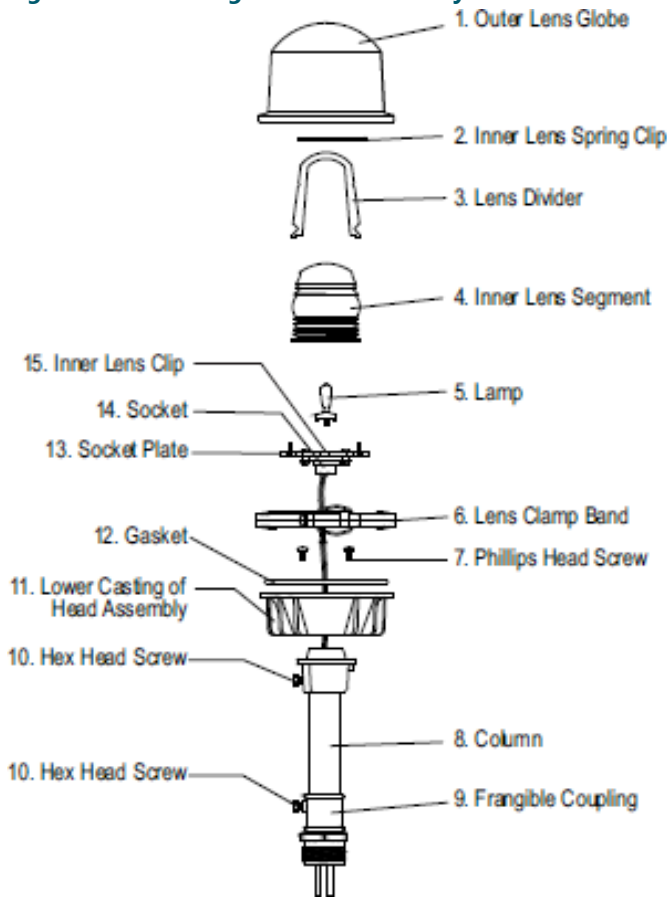

4.2 Installation

This subsection provides installation instructions for the L-861SE light fixture.

4.2.1 Placement

The L-861SE light fixtures are located 2 to 10 feet (0.6 to 3 m) from the edge of the full strength pavement runway and in a straight line on each side of the runway. The fixtures are spaced longitudinally not more than 200 feet (61 m) apart on a line such that the light units on opposite sides of the runway are perpendicular to the runway centerline.

4.2.2 Base Mounting

See [Figure 3](#). The L-861SE light fixtures can be mounted on an L-867 base (2) mated with a base plate (1) with a diameter and bolt-hole circle corresponding to either a 12-inch or 16-inch L-867 base. The base plate has a female thread to receive a frangible coupling. A gasket is used with the base plate to form a watertight seal between the base plate and the L-867 base.

To install the L-867 base, perform the following procedure:

1. Install the L-867 base on undisturbed soil. If the soil is unsuitable, remove soil to an adequate depth and replace with compacted acceptable material.

i Note

In closed duct systems, install in soil conditions with good drainage. Use light bases having a drain hole to prevent water accumulation.

2. Orient the cable entrance hubs of the base in the proper directions.
3. Level the light base so that the mounting flange surface is level with the finished grade.
4. With the base at the proper orientation and held at proper elevation, place approximately 4 inches (10.16 cm) of concrete backfill (7) around the outside base.

i Note

If the concrete backfill is omitted, the earth backfill must be compacted to maintain proper elevation and orientation of the base.

5. Slope the top of the concrete away from the flange portion of the base so the sloped outer edges of the concrete are at surface grade.

Figure 2: Base Mounting

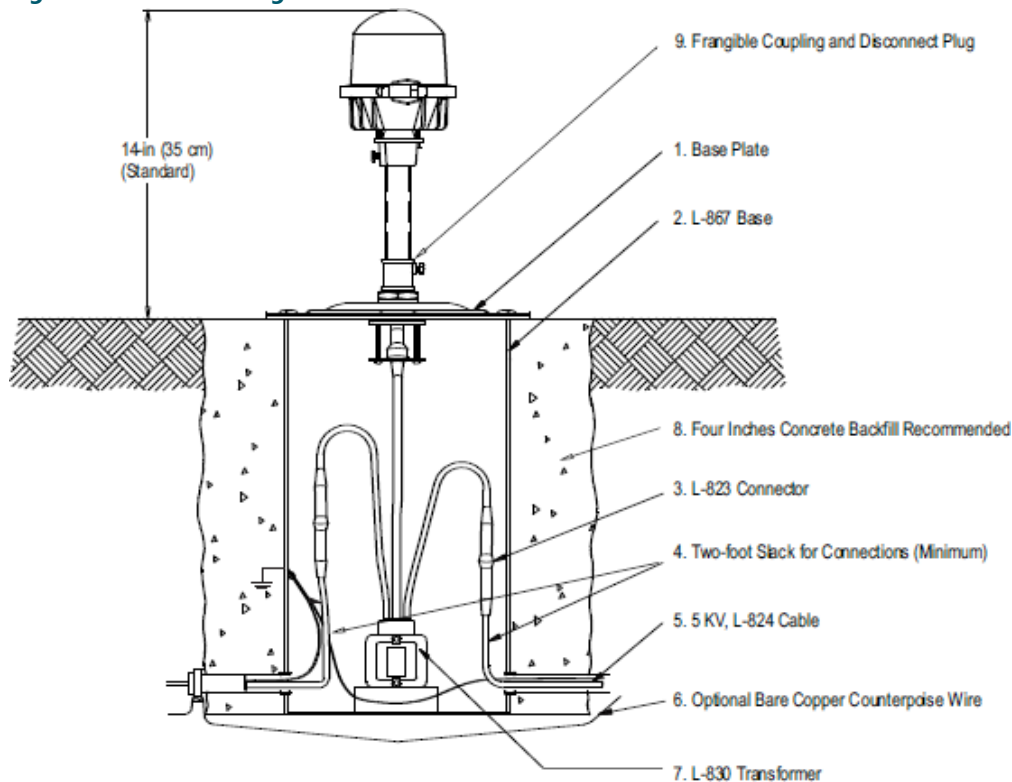

4.2.3 Light Fixture Mounting

To install the light fixture on the base, perform the following procedure:

1. See [Figure 3](#). Connect the primary power line to the appropriate isolation transformer. Refer to [Table 3](#) for the appropriate isolation transformer.

i Note

Use a brick to raise the isolation transformer so that it is about 3 inches (76.2 mm) above the bottom surface of the L-867 base (2) to avoid the possibility of the transformer being partially immersed in water in case water accumulates under the level of the ducts or pipes.

2. After you have connected the transformer, check the continuity of the series loop.

3. Wrap the connector joints in the primary circuit with at least one layer of rubber or synthetic rubber tape and one layer of plastic tape one-half lapped, extending at least 1-1/2 inches (3.81 mm) on each side of the joint.
4. Clamp the female secondary plug from the L-830 transformer to the L-867 base plate fitting.
5. Bolt the base plate (1) with the base plate gasket to the L-867 base using six 3/8 16 stainless steel bolts. Apply a drop of Loctite Grade AV to each bolt thread and use a torque wrench to torque bolts to 100 inch-pounds (11.3 Nt-m).
6. Connect the male L-823 plug (3) from the light fixture to the female transformer plug on the secondary lead of the L-830 transformer.
7. See [Figure 1](#). Loosen the frangible coupling screw (10) holding the coupling (9) to the light fixture column (8). Screw the coupling into the female thread on the base plate.



Note

Apply anti-seize compound to the coupling threads to improve coupling removal and prevent thread corrosion.

8. Install the column with light fixture attached on the frangible coupling and tighten the coupling screw. Refer to Assembly Instructions in this section.
9. Remove the outer globe (1), if installed. Place a level (such as a circle bubble level) on top of the head assembly and level the light fixture by adjusting the four Phillips head screws (7) in the lower casting (11).
10. See [Figure 4](#). Place the outer globe on the fixture, and check for outer globe and inner lens direction.



Note

To verify that the lens is oriented correctly, the arrows on top of the lens must point to the runway side. Arrows should point toward the runway when the fixture is installed parallel with the runway or when the fixtures are installed perpendicular to the runway to mark a displaced threshold. When fixtures are located at the end of the runway, the arrows should point to the imaginary extension of the runway centerline. Always make sure that the colored lens location is in compliance with the airport project plans and specifications.

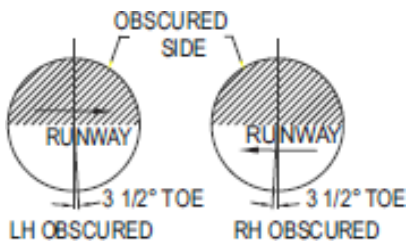

4.2.4 Stake Mounting

This section describes procedures for assembling and mounting the stake.

4.2.5 Stake Assembly

To assemble the stake, perform the following procedure:

1. See [Figure 6](#). Attach the stake hub (2) to the metal stake (5) using two 3/8 16 x 3/4-in. hex head screws (3) and 3/8-in. lockwashers (4).
2. Insert female L-823 secondary connector in cable connector support's forked tine and attach the cable connector support (7) to the stake hub (2) using 1/4 20 x 3/4-in. hex head screw (8) and 1/4-in. split lockwasher (9).



Note

The small hole at the lower end of the stake is provided for counterpoise wire connection.

Figure 3: Stake Mounting

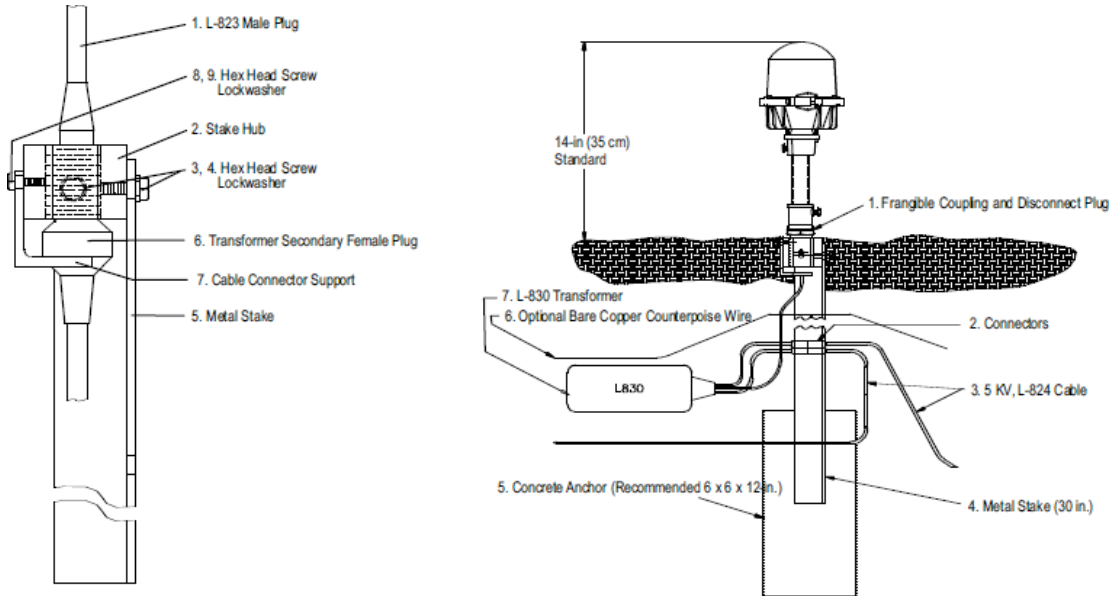

4.2.6 Stake Installation

The light fixture is mated with a 30-inch (762-mm) steel stake with a fitting attached at the top to receive the male thread of the frangible coupling. Stake mounting requires transformers, cables, and connectors that are designed for direct earth burial.

To install a stake, perform the following procedure:

1. See Figure 7. Install the stake (4) in 6-inch (152.4-mm) diameter holes at a depth of 30 inches (762 mm) so that the mounting hub of the stake is level.



CAUTION

- Do not drive stakes. Driving a stake may damage the stake and cause light fixture misalignment. Refer to FAA specification AC 150/5340-24.

2. Make electrical connections as required and backfill around the stake with thoroughly compacted earth that has passed through a 1-inch (25.4-mm) sieve.



Note

Backfill with concrete in case of unstable soil conditions.

3. Install the top of the stake even with ground level and maintain within 1 degree of the vertical.



Note

In areas where frost may cause heaving, anchor the stake with concrete and use a permeable backfill material such as sand around the buried electrical components. Cover the top surface with an impervious material to reduce moisture penetration.

4. Insert the male L-823 plug from the light fixture into the secondary receptacle of the transformer, and install the light fixture on the stake. Refer to Assembly Instructions in this section for light fixture assembly procedures.



CAUTION

- When installing the light fixture on the stake, avoid twisting wires. Twisting wires may damage wire connections, create a fire hazard, and adversely affect equipment performance.
-

5. See [Figure 2](#) . Remove the outer globe (1), if installed. Place a level (such as a circle bubble level) on top of the head assembly and level the light fixture by adjusting the four Phillips head screws (7) in the lower casting (11).
 6. See [Figure 4](#) . Place the outer globe on the fixture, and check for outer globe and inner lens direction.
-



Note

To verify that the lens is oriented correctly, the arrows on top of the lens must point to the runway side. Arrows should point toward the runway when the fixture is installed parallel with the runway or when the fixtures are installed perpendicular to the runway to mark a displaced threshold. When fixtures are located at the end of the runway, the arrows should point to the imaginary extension of the runway centerline. Always make sure that the colored lens location is in compliance with the airport project plans and specifications.

5.0 Maintenance

5.1 Periodic Maintenance Schedule

To keep L-861SE threshold/end light fixtures operating efficiently, follow a preventive maintenance schedule. Refer to [Table 6](#). Refer to FAA AC 150/5340-26 for more detailed information.

Table 4: L-861SE Threshold/End Light Fixture Maintenance

Interval	Maintenance Task	Action	Refer to:
Daily	Check for burned out lamp.	After turning off power, replace burned-out lamps. Refer to the Repair section.	
	Check for dim lamp.	After turning off power, replace burned-out lamps. Refer to the Repair section. After turning off power, check isolation transformer on series circuit.	
	Check for broken lens.	Replace lens.	Maintenance Procedures
Weekly	Check for vegetation.	Remove vegetation. Use weed killer.	
	Check for dirty lens.	Clean with glass cleaner.	
Monthly	Check for misaligned fixture.	Straighten, level, and align.	
	Check for dirty lamp socket.	After turning off power, clean lamp socket.	Maintenance Procedures
	Check for dirty frangible coupling weep holes (stake-mounted fixtures only).	Clean frangible coupling weep holes.	
	Check for dirt on fixture drain holes.	Clean drain holes.	
Semiannually	Check for improper ground elevation.	Grade so frangible point is level with ground elevation.	
	Check for improper light elevation.	Maintain the same elevation for all light fixtures.	
	Check for moisture present in light housing or base.	Check drain holes and clamps. Check lens for cracks. If damaged, replace. Use water pump to remove water from the base.	
	Check for corrosion or loose or chipped paint.	Scrape and repaint.	
Annually	Check for cracks, corrosion, and shorts.	Repair or replace.	Maintenance Procedures
	Check for dirty contacts.	After turning off power, clean contacts.	Maintenance Procedures
	Check for loose wire connections.	Tighten wire connections.	
Unscheduled	Make prediction of heavy snowfall, if necessary.	Use red flags or sticks to mark the location of fixtures to facilitate snow removal and lessen the chance of damage to fixtures by snow removal equipment.	

5.2 Maintenance Procedures

This section provides instructions for replacing lamps for the L-861SE threshold/end light fixture.



WARNING

De-energize the circuit and lock out the circuit or regulator so that the circuit cannot be energized by remote means before attempting to service the fixture.

- Failure to observe a warning may result in personal injury, death or equipment damage.

To replace a lamp, perform the following procedure:

1. See [Figure 4](#). Remove the outer globe (H2) from the fixture by loosening the clamp band holding the lens to the base.
2. Remove the two inner lens segments (H1R/L) by pulling and sliding off the inner spring clip (H3) and the Inner Lens Clip (C1).
3. Pull the lamp (L1) from the socket (S1).
4. Wearing clean, lint-free gloves, insert the new 2-pin lamp into the lamp socket.



CAUTION

Touching quartz lamps with bare fingers may seriously shorten lamp life. If the quartz lamp has been touched, clean the lamp with tissue moistened with isopropyl alcohol.

- Failure to observe a warning may result in equipment damage.

5. Reinstall the inner lens segments and outer lens by reversing the removal procedure.
6. Reinstall the outer lens.
7. Clamp the latch on the outer lens.

5.3 Troubleshooting

5.3.1 Action Table in the Event of a System or Component Malfunction

This section contains troubleshooting information. This information covers only the most common problems that you may encounter. If you cannot solve the problem with the information given here, contact your local ADB Safegate representative for help.

Table 5: Product ERTE Troubleshooting Guide Table

Problem	Possible Cause	Corrective Action
Lamp not energizing	Defective lamp	Replace the lamp
	Loose or broken contacts	Replace the lamp or light socket
	Power supply failure	Replace the power supply
	Fixture wires pinched	Replace/repair the wire
	Defective isolation transformer	Replace the transformer
Lamp not turning on at normal level	Isolation transformer secondary current incorrect or wrong frequency type	Check for the proper transformer size and replace with the correct transformer
	Wrong fixture installed	Replace the fixture
Improper color	inner lens broken	Replace inner lens
	inner lens not installed or wrong color	
Short lamp life	Current too high (series circuit applications)	Calibrate the CCR
	Cracked lens or base assembly	Replace the broken assembly. Clean and reassemble the light fixture.
	Component Failure	Replace the failed component. Check for a cause of the failure and repair or replace any defective components.

6.0 Parts

Ordering Code

44A2090 - X X X X

Lamp

1 = 110-120 W/6.6 A Quartz³

Inner Lens Color

3 = White/Red¹

4 = White/Green¹

6 = Red/Green²

7 = Red/Red¹

8 = Green/Green²

9 = Green/Yellow¹

Fixture Height

1 = 14 in (35.6 cm) with 1.5" coupling, 12 TPI

2 = 24 in (61.0 cm) with 1.5" coupling, 12 TPI

3 = 30 in (76.2 cm) with 1.5" coupling, 12 TPI

Outer Lens

1 = Not Obscured

2 = Obscured

Notes

¹ Color and/or color configuration not recognized by FAA.

² Configurations 44A2090-16X1 Red/Green and 44A2090-18X2 Unidirectional Green are ETL Certified.

³ Can be supplied with 110 W, 115 W or 120 W lamp based on availability

6.1 Product Major Components

Table 6: Spare Components

Description	Part No.
Column 1", 7.25" (18.42 cm) for 14" OAH	62A0007-7
Column 1", 17.25" (43.82 cm) for 24" OAH	62A0007-17
Column 1", 23.25" (59.06 cm) for 30" OAH	62A0007-23
Frangible coupling, 1.5 inch, 12 TPI	62B0073/SPARE
Clamp band assembly	44A2060
Frangible coupling, 1.5 inch, 12 TPI, with slot	62B0461/SPARE
Gasket	63A0640
Head assembly w/clamp band, gasket, socket, mounting plate, and 24-in cord set	44A2080-1
Head assembly w/clamp band, gasket, socket, mounting plate, and 14-in cord set	44A2080-2
Head assembly w/clamp band, gasket, socket, mounting plate, and 30-in cord set	44A2080-3
Inner lens clip	60C2041
Inner lens, bracket	61A0146
Inner lens, spring clip	65A0163
Lamp, 110-120 W/6.6 A	48A0069
Lens, inner - 180° segment, white	63B0415-1
Lens, inner - 180° segment, yellow	63B0415-2
Lens, inner - 180° segment, red	63B0415-3

Table 6: Spare Components (continued)

Description	Part No.
Lens, inner - 180° segment, green	63B0415-4
Outer lens, white bidirectional	63B0480
Socket mounting plate assembly (includes socket, mounting plate and inner lens clip)	44A2089

Notes

¹ Slot across threaded end allows easy replacement of broken frangible coupling

6.2 Illustrated Parts List or Exploded View Diagram

Figure 4: ERTE Assembly (see Tables 4-7)

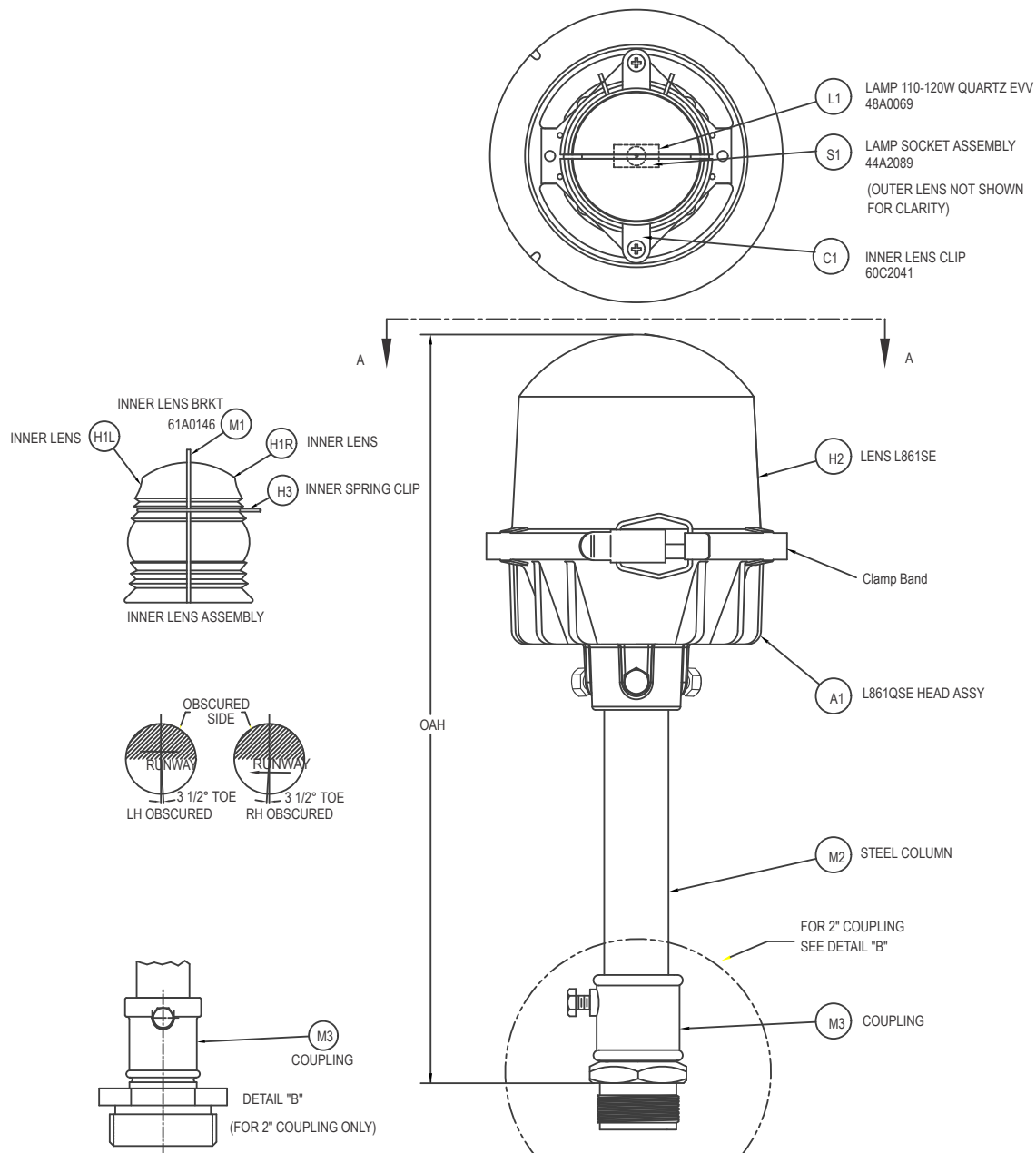

Table 7: H1R/L Inner Lens

ASSEMBLY NUMBER	PART NUMBER	ITEM NO.	PART NAME/DESCRIPTION	QTY.
44A2090/X1XX	63B0415/1	H1L	Inner Lens, Clear	1
	63B0415/1	H1R	Inner Lens, Clear	1
44A2090/X2XX	63B0415/1	H1L	Inner Lens, Clear	1
	63B0415/2	H1R	Inner Lens, Yellow	1
44A2090/X3XX	63B0415/1	H1L	Inner Lens, Clear	1
	63B0415/3	H1R	Inner Lens, Red	1
44A2090/X4XX	63B0415/1	H1L	Inner Lens, Clear	1
	63B0415/4	H1R	Inner Lens, Green	1
44A2090/X5XX	63B0415/2	H1L	Inner Lens, Yellow	1
	63B0415/3	H1R	Inner Lens, Red	1
44A2090/X6XX	63B0415/3	H1L	Inner Lens, Red	1
	63B0415/4	H1R	Inner Lens, Green	1
44A2090/X7XX	63B0415/3	H1L	Inner Lens, Red	1
	63B0415/3	H1R	Inner Lens, Red	1
44A2090/X8XX	63B0415/4	H1L	Inner Lens, Green	1
	63B0415/4	H1R	Inner Lens, Green	1
44A2090/X9XX	63B0415/4	H1L	Inner Lens, Green	1
	63B0415/2	H1R	Inner Lens, Yellow	1
44A2090/XAXX	63B0415/3	H1L	Inner Lens, Red	1
	63B0415/5	H1R	Inner Lens, Blue	1
44A2090/XBXX	63B0415/5	H1L	Inner Lens, Blue	1
	63B0415/5	H1R	Inner Lens, Blue	1

Table 8: A1 and M2 Column and Head Assembly

ASSEMBLY NUMBER	PART NUMBER	ITEM NO.	PART NAME/DESCRIPTION	QTY.
44A2090/XX1X	44A2080/1	A1	Head Assy For 14" OAH	1
44A2090/XX5X	62A0007/8	M2	6.5" Column For 14" OAH	1
44A2090/XX2X	44A2080/2	A1	Head Assy For 24" OAH	1
44A2090/XX6X	62A0007/18	M2	16.5" Column For 24" OAH	1
44A2090/XX3X	44A2080/3	A1	Head Assy For 30" OAH	1
44A2090/XX7X	62A0007/24	M2	22.5" Column For 30" OAH	1

Table 9: H2 Outer Lens

ASSEMBLY NUMBER	PART NUMBER	ITEM NO.	PART NAME/DESCRIPTION	QTY.
44A2090/XXX1	63B0480	H2	Outer Lens, Clear	1
44A2090/XXX2	63B0580	H2	Outer Lens, Clear/ obscured	1

Table 10: M3 Coupling

ASSEMBLY NUMBER	PART NUMBER	ITEM NO.	PART NAME/ DESCRIPTION	QTY.
44A2090/XX1X	62B0073/SPARE	M3	14" OAH, 1-1/2" Coupling	1
44A2090/XX2X	62B0073/SPARE	M3	24" OAH, 1-1/2" Coupling	1
44A2090/XX3X	62B0073/SPARE	M3	30" OAH, 1-1/2" Coupling	1
44A2090/XX5X	61A0281/SPARE	M3	14" OAH, 2" Coupling	1
44A2090/XX6X	61A0281/SPARE	M3	24" OAH, 2" Coupling	1
44A2090/XX7X	61A0281/SPARE	M3	30" OAH, 2" Coupling	1

Table 11: Stake Mounting and Hardware

Item	Description	Part Number	Quantity	Note
NS	Stake assembly	44B0348	1	
NS	Stake hardware only	44A2158	1	
NS	Stake only	62B0284	1	

Appendix A: SUPPORT

Our experienced engineers are available for support and service at all times, 24 hour/7 days a week. They are part of a dynamic organization making sure the entire ADB SAFEGATE is committed to minimal disturbance for airport operations.

ADB SAFEGATE Support

Live Technical Support - Americas

If at any time you have a question or concern about your product, just contact ADB SAFEGATE's technical service department. Trained in all areas of system issues, troubleshooting, quality control and technical assistance, our highly experienced Technical support specialists are available 24 hours a day, seven days a week to provide assistance over the phone.

ADB SAFEGATE **Americas Technical Service & Support (US & Canada): +1-800-545-4157**

ADB SAFEGATE Americas Technical Service & Support (International): +1-614-861-1304

During regular business hours, you can also Chat with a Service Technician. We look forward to working with you!

Before You Call

When you have an airfield lighting or system control system problem it is our goal to support airfield maintenance staff as quickly as possible. To support this effort we ask that you have the following information ready before calling.

- The *airport code*
- If not with an airport, then company name (prefer customer id number)
- Contact phone number and email address
- Product with part number preferable or product number
- Have you reviewed the product's manual and troubleshooting guide
- Do you have a *True RMS* meter available (and any other necessary tools)
- Be located with the product ready to troubleshoot

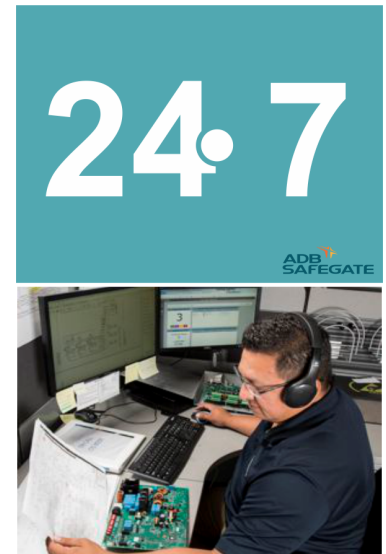

Note

For more information, see www.adbsafegate.com, or contact ADB SAFEGATE Support via email at support@adbsafegate.com or

Brussels: +32 2 722 17 11

Rest of Europe: +46 (0) 40 699 17 40

Americas: +1 614 861 1304. Press 3 for technical service or press 4 for sales support.

China: +86 (10) 8476 0106

A.1 ADB SAFEGATE Website

The ADB SAFEGATE website, www.adbsafegate.com, offers information regarding our airport solutions, products, company, news, links, downloads, references, contacts and more.

A.2 Recycling

A.2.1 Local Authority Recycling

The disposal of ADB SAFEGATE products is to be made at an applicable collection point for the recycling of electrical and electronic equipment. The correct disposal of equipment prevents any potential negative consequences for the environment and human health, which could otherwise be caused by inappropriate waste handling. The recycling of materials helps to conserve natural resources. For more detailed information about recycling of products, contact your local authority city office.

A.2.2 ADB SAFEGATE Recycling

ADB SAFEGATE is fully committed to environmentally-conscious manufacturing with strict monitoring of our own processes as well as supplier components and sub-contractor operations. ADB SAFEGATE offers a recycling program for our products to all customers worldwide, whether or not the products were sold within the EU.

ADB SAFEGATE products and/or specific electrical and electronic component parts which are fully removed/separated from any customer equipment and returned will be accepted for our recycling program.

All items returned must be clearly labeled as follows:

- For *ROHS/WEEE* Recycling
- Sender contact information (Name, Business Address, Phone number).
- Main Unit Serial Number.

ADB SAFEGATE will continue to monitor and update according for any future requirements for *EU directives* as and when *EU member states* implement new *regulations* and or *amendments*. It is our aim to maintain our *compliance plan* and assist our customers.

Company Addresses

ADB SAFEGATE	ADB SAFEGATE, Belgium: Leuvensesteenweg 585, B-1930 Zaventem Belgium
Contact: Tel.: +32 2 722 17 11, Fax: +32 2 722 17 64	Email: marketing@adbsafegate.com Internet: www.adbsafegate.com
Americas LLC	ADB SAFEGATE, Americas: 977 Gahanna Parkway, Columbus, OH 43230 USA
Contact: Tel.: +1 (614) 861 1304, Fax: +1 (614) 864 2069	Email: sales.us@adbsafegate.com Internet: www.adbsafegate.com
ADB SAFEGATE Sweden AB	ADB SAFEGATE, Sweden: Djurhagegatan 19 SE-213 76 Malmö Sweden
Contact: Tel.: +46 (0)40 699 17 00, Fax: +46 (0)40 699 17 30	Email: marketing@adbsafegate.com Internet: www.adbsafegate.com
ADB SAFEGATE Airfield Technologies Ltd. China	ADB SAFEGATE, China: Unit 603, D Block, CAMIC International Convention Center, No 3, Hua Jia Di East road, ChaoYang district, Beijing 100102 P.R. China
Contact: Tel.: +86 (10) 8476 0106, Fax: +86 (10) 8476 0090	Email: china@safegate.com Internet: www.adbsafegate.com
ADB SAFEGATE Germany GmbH	ADB SAFEGATE Germany GmbH, Mannheim: Konrad-Zuse-Ring 6, D-68163 Mannheim Germany
Contact: Tel.: +49 (621) 87 55 76-0, Fax: +49 (621) 87 55 76-55	Email: marketing@adbsafegate.com Internet: www.adbsafegate.com



Powering Your Airport Performance from Approach to Departure

adbsafegate.com

Copyright © ADB SAFEGATE, all rights reserved

