



DRC-LP/DTZ-LP/DFS-LP (Low Protrusion)
LED Runway Centerline, LED Touchdown Zone, Rapid Exit
Taxiway Indicator Lights (RETIL) and Enhanced Rapid Exit Taxiway
Centerline Lights

User Manual

96A0465, Rev. I, 2021/04/22

**ADB
SAFEGATE**

A.0 Disclaimer / Standard Warranty

CE certification

The equipment listed as CE certified means that the product complies with the essential requirements concerning safety and hygiene. The European directives that have been taken into consideration in the design are available on written request to ADB SAFEGATE.

ETL certification

The equipment listed as ETL certified means that the product complies with the essential requirements concerning safety and FAA Airfield regulations. The FAA directives that have been taken into consideration in the design are available on written request to ADB SAFEGATE.

All Products Guarantee

ADB SAFEGATE will correct by repair or replacement per the applicable guarantee above, at its option, equipment or parts which fail because of mechanical, electrical or physical defects, provided that the goods have been properly handled and stored prior to installation, properly installed and properly operated after installation, and provided further that Buyer gives ADB SAFEGATE written notice of such defects after delivery of the goods to Buyer. Refer to the Safety section for more information on Material Handling Precautions and Storage precautions that must be followed.

ADB SAFEGATE reserves the right to examine goods upon which a claim is made. Said goods must be presented in the same condition as when the defect therein was discovered. ADB SAFEGATE further reserves the right to require the return of such goods to establish any claim.

ADB SAFEGATE's obligation under this guarantee is limited to making repair or replacement within a reasonable time after receipt of such written notice and does not include any other costs such as the cost of removal of defective part, installation of repaired product, labor or consequential damages of any kind, the exclusive remedy being to require such new parts to be furnished.

ADB SAFEGATE's liability under no circumstances will exceed the contract price of goods claimed to be defective. Any returns under this guarantee are to be on a transportation charges prepaid basis. For products not manufactured by, but sold by ADB SAFEGATE, warranty is limited to that extended by the original manufacturer. This is ADB SAFEGATE's sole guarantee and warranty with respect to the goods; there are no express warranties or warranties of fitness for any particular purpose or any implied warranties of fitness for any particular purpose or any implied warranties other than those made expressly herein. All such warranties being expressly disclaimed.

Standard Products Guarantee

Products of ADB SAFEGATE manufacture are guaranteed against mechanical, electrical, and physical defects (excluding lamps) which may occur during proper and normal use for a period of two years from the date of ex-works delivery, and are guaranteed to be merchantable and fit for the ordinary purposes for which such products are made.



Note

See your sales order contract for a complete warranty description.

FAA Certified product installed in the United States and purchased or funded with monies through the Airport Improvement Program (AIP) installations guarantee

ADB SAFEGATE L858 Airfield Guidance Signs are warranted against mechanical and physical defects in design or manufacture for a period of 2 years from date of installation, per FAA AC 150/5345-44 (applicable edition).

ADB SAFEGATE L858(L) Airfield Guidance Signs are warranted against electrical defects in design or manufacture of the LED or LED specific circuitry for a period of 4 years from date of installation, per FAA EB67 (applicable edition).

ADB SAFEGATE LED light fixtures (with the exception of obstruction lighting) are warranted against electrical defects in design or manufacture of the LED or LED specific circuitry for a period of 4 years from date of installation, per FAA EB67 (applicable edition).



Note

See your sales order contract for a complete warranty description.

Liability



WARNING

Use of the equipment in ways other than described in the catalog leaflet and the manual may result in personal injury, death, or property and equipment damage. Use this equipment only as described in the manual.

ADB SAFEGATE cannot be held responsible for injuries or damages resulting from non-standard, unintended uses of its equipment. The equipment is designed and intended only for the purpose described in the manual. Uses not described in the manual are considered unintended uses and may result in serious personal injury, death or property damage.

Unintended uses, includes the following actions:

- Making changes to equipment that have not been recommended or described in this manual or using parts that are not genuine ADB SAFEGATE replacement parts or accessories.
- Failing to make sure that auxiliary equipment complies with approval agency requirements, local codes, and all applicable safety standards if not in contradiction with the general rules.
- Using materials or auxiliary equipment that are inappropriate or incompatible with your ADB SAFEGATE equipment.
- Allowing unskilled personnel to perform any task on or with the equipment.

© ADB SAFEGATE BV

This manual or parts thereof may not be reproduced, stored in a retrieval system, or transmitted, in any form or by any means, electronic, mechanical, photocopying, recording, nor otherwise, without ADB SAFEGATE BV's prior written consent.

This manual could contain technical inaccuracies or typographical errors. ADB SAFEGATE BV reserves the right to revise this manual from time to time in the contents thereof without obligation of ADB SAFEGATE BV to notify any person of such revision or change. Details and values given in this manual are average values and have been compiled with care. They are not binding, however, and ADB SAFEGATE BV disclaims any liability for damages or detriments suffered as a result of reliance on the information given herein or the use of products, processes or equipment to which this manual refers. No warranty is made that the use of the information or of the products, processes or equipment to which this manual refers will not infringe any third party's patents or rights. The information given does not release the buyer from making their own experiments and tests.

TABLE OF CONTENTS

1.0 Safety	1
1.1 Safety Messages	1
1.1.1 Introduction to Safety	2
1.1.2 Intended Use	2
1.1.3 Material Handling Precautions: Storage	3
1.1.4 Material Handling Precautions: Fasteners	3
1.1.5 Operation Safety	4
1.1.6 Maintenance Safety	4
1.1.7 Material Handling Precautions, ESD	5
1.1.8 Arc Flash and Electric Shock Hazard	5
2.0 LED Runway Centerline and Touchdown Zone In-pavement Light	7
2.1 Introduction	7
2.2 LED Runway Centerline and Touchdown Zone Inset Light	7
3.0 Installation	11
3.1 Installation Overview	11
3.2 INTEROPERABILITY	11
3.3 Typical L-868 Assembly	12
3.4 Safety Considerations	13
3.5 Photobiological safety	13
3.6 Verify Input Requirements and Equipment Needed	13
3.7 Unpacking the Unit	14
3.8 Inspect on delivery	14
3.9 Store	15
3.10 Toe-in Location Only	15
3.11 Installation on L-868 Base	15
3.12 Torquing and Installation Guidance for In-pavement Fixtures	16
3.13 Shallow base can installation	17
3.13.1 Installation on a Shallow Base	17
4.0 Maintenance	19
4.1 Safety Considerations	19
4.2 Maintenance	20
4.3 Removing L-868 Base Water	20
4.4 Lifting Optical Unit Out of Base	20
4.5 Repair Procedures	21
4.5.1 Opening the Optical Unit	21
4.5.2 Removing the LED Assembly	22
4.5.3 Cleaning the Light Channel and Prism	22
4.5.4 Replace the fuse resistor (monitoring option)	22
4.5.5 Replacing Prism	23
4.5.6 Replace cable lead	25
4.5.7 Replace labyrinth gasket (8" only)	25
4.5.8 Closing the Optical Unit	27
4.5.9 Fastener Torque Table	28
4.5.10 Adhesives and Lubricants	29
4.5.11 Testing for Leaks	29
4.6 Material Handling Precautions: Fasteners	31
4.7 Bolt Torque Preventive Maintenance Schedule	32
5.0 Troubleshooting	35
6.0 DRC/DTZ Parts	37
A.0 SUPPORT	43
A.1 ADB SAFEGATE Website	43
A.2 Recycling	44

A.2.1 Local Authority Recycling	44
A.2.2 ADB SAFEGATE Recycling	44

1.0 Safety

Introduction to Safety





This section contains general safety instructions for installing and using ADB SAFEGATE equipment. Some safety instructions may not apply to the equipment in this manual. Task- and equipment-specific warnings are included in other sections of this manual where appropriate.

1.1 Safety Messages

HAZARD Icons used in the manual

For all HAZARD symbols in use, see the Safety section. All symbols must comply with ISO and ANSI standards.

Carefully read and observe all safety instructions in this manual, which alert you to safety hazards and conditions that may result in personal injury, death or property and equipment damage and are accompanied by the symbol shown below.

	<p>WARNING Failure to observe a warning may result in personal injury, death or equipment damage.</p>
	<p>DANGER - Risk of electrical shock or ARC FLASH Disconnect equipment from line voltage. Failure to observe this warning may result in personal injury, death, or equipment damage. ARC Flash may cause blindness, severe burns or death.</p>
	<p>WARNING - Wear personal protective equipment Failure to observe may result in serious injury.</p>
	<p>WARNING - Do not touch Failure to observe this warning may result in personal injury, death, or equipment damage.</p>
	<p>CAUTION Failure to observe a caution may result in equipment damage.</p>

Qualified Personnel

	<p>Important Information The term qualified personnel is defined here as individuals who thoroughly understand the equipment and its safe operation, maintenance and repair. Qualified personnel are physically capable of performing the required tasks, familiar with all relevant safety rules and regulations and have been trained to safely install, operate, maintain and repair the equipment. It is the responsibility of the company operating this equipment to ensure that its personnel meet these requirements. Always use required personal protective equipment (PPE) and follow safe electrical work practice.</p>
---	---

1.1.1 Introduction to Safety



CAUTION

Unsafe Equipment Use

This equipment may contain electrostatic devices, hazardous voltages and sharp edges on components

- Read installation instructions in their entirety before starting installation.
- Become familiar with the general safety instructions in this section of the manual before installing, operating, maintaining or repairing this equipment.
- Read and carefully follow the instructions throughout this manual for performing specific tasks and working with specific equipment.
- Make this manual available to personnel installing, operating, maintaining or repairing this equipment.
- Follow all applicable safety procedures required by your company, industry standards and government or other regulatory agencies.
- Install all electrical connections to local code.
- Use only electrical wire of sufficient gauge and insulation to handle the rated current demand. All wiring must meet local codes.
- Route electrical wiring along a protected path. Make sure they will not be damaged by moving equipment.
- Protect components from damage, wear, and harsh environment conditions.
- Allow ample room for maintenance, panel accessibility, and cover removal.
- Protect equipment with safety devices as specified by applicable safety regulations
- If safety devices must be removed for installation, install them immediately after the work is completed and check them for proper functioning prior to returning power to the circuit.

Failure to follow this instruction can result in serious injury or equipment damage

Additional Reference Materials



Important Information

- IEC - International Standards and Conformity Assessment for all electrical, electronic and related technologies.
- IEC 60364 - Electrical Installations in Buildings.
- FAA Advisory: AC 150/5340-26 (current edition), Maintenance of Airport Visual Aid Facilities.
- Maintenance personnel must refer to the maintenance procedure described in the ICAO Airport Services Manual, Part 9.
- ANSI/NFPA 79, Electrical Standards for Metalworking Machine Tools.
- National and local electrical codes and standards.

1.1.2 Intended Use



CAUTION

Use this equipment as intended by the manufacturer

This equipment is designed to perform a specific function, do not use this equipment for other purposes

- Using this equipment in ways other than described in this manual may result in personal injury, death or property and equipment damage. Use this equipment only as described in this manual.

Failure to follow this instruction can result in serious injury or equipment damage

1.1.3 Material Handling Precautions: Storage



CAUTION

Improper Storage

Store this equipment properly

- If equipment is to be stored prior to installation, it must be protected from the weather and kept free of condensation and dust.

Failure to follow this instruction can result in equipment damage

1.1.4 Material Handling Precautions: Fasteners



DANGER

Foreign Object Damage - FOD

This equipment may contain fasteners that may come loose - torque properly.

- Only use fasteners of the same type as the one originally supplied with the equipment.
- Use of incorrect combination of gaskets, bolts and nuts can create severe damages to the product installation and create safety risk .
- You need to know what base the light fixture will be installed in, in order to chose the correct gasket, bolts and nuts.
- Bolt type, length, and torque value are determined by type of base, height of spacers used, and clamp force required in FAA Engineering Brief No 83 (latest revision).
- Due to the risk of bolts vibrating loose, do not use any type of washer with the fixing bolts (such as split lock washers) other than an anti-vibration washer. Anti-vibration washers as defined in FAA EB 83 (latest edition) must be used. For installations other than FAA, use the base can manufacturer's recommendations.
- Always tighten the fasteners to the recommended torque. Use a calibrated torque wrench and apply the recommended adhesive type.
- Obey the instructions of the adhesives necessary for the fasteners.

Failure to follow these warnings may cause the fasteners to loosen, damage the equipment, potentially to loosen the equipment. This can lead to a highly dangerous situation of FOD, with potential lethal consequences.



Note

To minimize the risk of errors, the ADB SAFEGATE Sales Representative will have information on which gasket goes with which base. This information is also provided in the product Data sheets, the User Manuals and the Spare Part Lists.



CAUTION

Use of incorrect combination of gaskets, bolts and nuts can create severe damages to the product installation and create multiple safety risks.

To obtain a safe and watertight installation the O-ring and retaining bolt stated in the document must be used.

You need to know what base the light fixture will be installed in, in order to choose the correct gasket, bolts and nuts.

Failure to follow these cautions can result in equipment damage or aircraft FOD.

1.1.5 Operation Safety



CAUTION

Improper Operation

Do Not Operate this equipment other than as specified by the manufacturer

- Only qualified personnel, physically capable of operating the equipment and with no impairments in their judgment or reaction times, should operate this equipment.
- Read all system component manuals before operating this equipment. A thorough understanding of system components and their operation will help you operate the system safely and efficiently.
- Before starting this equipment, check all safety interlocks, fire-detection systems, and protective devices such as panels and covers. Make sure all devices are fully functional. Do not operate the system if these devices are not working properly. Do not deactivate or bypass automatic safety interlocks or locked-out electrical disconnects or pneumatic valves.
- Protect equipment with safety devices as specified by applicable safety regulations.
- If safety devices must be removed for installation, install them immediately after the work is completed and check them for proper functioning.
- Route electrical wiring along a protected path. Make sure they will not be damaged by moving equipment.
- Never operate equipment with a known malfunction.
- Do not attempt to operate or service electrical equipment if standing water is present.
- Use this equipment only in the environments for which it is rated. Do not operate this equipment in humid, flammable, or explosive environments unless it has been rated for safe operation in these environments.
- Never touch exposed electrical connections on equipment while the power is ON.

Failure to follow these instructions can result in equipment damage

1.1.6 Maintenance Safety



DANGER

Electric Shock Hazard

This equipment may contain electrostatic devices

- Do not operate a system that contains malfunctioning components. If a component malfunctions, turn the system OFF immediately.
- Disconnect and lock out electrical power.
- Allow only qualified personnel to make repairs. Repair or replace the malfunctioning component according to instructions provided in its manual.

Failure to follow these instructions can result in death or equipment damage

1.1.7 Material Handling Precautions, ESD



CAUTION

Electrostatic Sensitive Devices

This equipment may contain electrostatic devices

- Protect from electrostatic discharge.
- Electronic modules and components should be touched only when this is unavoidable e.g. soldering, replacement.
- Before touching any component of the cabinet you shall bring your body to the same potential as the cabinet by touching a conductive earthed part of the cabinet.
- Electronic modules or components must not be brought in contact with highly insulating materials such as plastic sheets, synthetic fiber clothing. They must be laid down on conductive surfaces.
- The tip of the soldering iron must be grounded.
- Electronic modules and components must be stored and transported in conductive packing.

Failure to follow this instruction can result in equipment damage

1.1.8 Arc Flash and Electric Shock Hazard



DANGER

Series Circuits have Hazardous Voltages

This equipment produces high voltages to maintain the specified current - Do NOT Disconnect while energized.

- Allow only qualified personnel to perform maintenance, troubleshooting, and repair tasks.
- Only persons who are properly trained and familiar with ADB SAFEGATE equipment are permitted to service this equipment.
- An open airfield current circuit is capable of generating >5000 Vac and may appear OFF to a meter.
- Never unplug a device from a constant current circuit while it is operating; Arc flash may result.
- Disconnect and lock out electrical power.
- Always use safety devices when working on this equipment.
- Follow the recommended maintenance procedures in the product manuals.
- Do not service or adjust any equipment unless another person trained in first aid and CPR is present.
- Connect all disconnected equipment ground cables and wires after servicing equipment. Ground all conductive equipment.
- Use only approved ADB SAFEGATE replacement parts. Using unapproved parts or making unapproved modifications to equipment may void agency approvals and create safety hazards.
- Check the interlock systems periodically to ensure their effectiveness.
- Do not attempt to service electrical equipment if standing water is present. Use caution when servicing electrical equipment in a high-humidity environment.
- Use tools with insulated handles when working with airfield electrical equipment.

Failure to follow these instructions can result in death or equipment damage

2.0 LED Runway Centerline and Touchdown Zone In-pavement Light

This user manual covers the LED In-pavement Runway Centerline and TDZ Light installation and maintenance.

2.1 Introduction

Compliance with Standards

FAA certified: Designed according to L-850A(L) and L-850B(L) AC 150/5345-46 and Engineering Brief No. 67 (Current Edition).

ICAO: Runway Centerline: Annex 14, Vol. 1, par. 5.3.12 and Appendix 2, Figure A2-7. Touchdown Zone: Annex 14, Vol. 1, par. 5.3.13 and Appendix 2, Figure A2-5.

Rapid Exit Taxiway Indicator Lights (RETIL): Annex 14, Vol. 1, par. 5.3.14 and Appendix 2, Fig. A2-7.

NATO: Compliant to STANAG 3316

T/C: Runway Centerline: Transport Canada TP 312 par. 5.3.13. Touchdown Zone: Transport Canada TP 312 par. 5.3.14.

CE: Complies with the requirements of the EMC Directive 2004/108/EC.

2.2 LED Runway Centerline and Touchdown Zone Inset Light

Compliance with Standards

ICAO:	Runway Centerline: Annex 14, Vol. 1, Ed. 6 par. 5.3.12 and Appendix 2, Figure A2-7. Touchdown Zone: Annex 14, Vol. 1, Ed. 6 par. 5.3.13 and Appendix 2, Figure A2-5. Rapid Exit Taxiway Indicator Light (RETIL): Annex 14, Vol. 1, Ed. 6 par. 15
FAA:	L- 850A(L) & L-850B(L) AC 150/5345-46 (Current Edition) and Engineering Brief No. 67. ETL Certified.
T/C:	Runway Centerline: Transport Canada TP 312 par. 5.3.13. Touchdown Zone: Transport Canada TP 312 par. 5.3.14.
NATO:	STANAG 3316

Uses

ICAO & T/C	<ul style="list-style-type: none"> Runway Centerline Light in CAT I, II and III Touchdown Zone Light in CAT II and III RETIL Light on CAT I, II and III
FAA L-850A(L)	<ul style="list-style-type: none"> Runway Centerline on CAT I, II, and III runways
FAA L-850B(L)	<ul style="list-style-type: none"> Touchdown Zone on CAT I, II, and III runways

Features

- The evolution of the most successful LED lights in the world, fully adapted to the characteristics of an LED lighting source.
- Greatly reduced maintenance: calculated MTBF of 56,000 hours at 6.6A.
- Style 3 - Low protrusion above ground of ≤ 0.25 inch (6.3 mm) reduces vibrations caused by aircraft landing gear, increasing fixture life.
- Increased traffic efficiency and availability of the runways due to the reduction of maintenance.
- Optimum and homogeneous light distribution along the lights installed on the same runway.
- High discrimination between functions due to the saturated colors, crisp white light, their stability at the different brightness steps and under all viewing angles.
- Full compatibility with existing airfield lighting series circuits. No need to replace CCRs, series transformers, or cables.

- Fully dimmable lights, respecting the response curve of traditional halogen lights. Operates on the full range of 2.8 A to 6.6 A.
- Installation on the same bases as 8- or 12-inch tungsten-halogen lights for a straightforward replacement. Optional snow plow rings are available.
- Substantial investment reduction for new installations using smaller CCR size and series transformers, resulting from a lower installed load.
- Very low working temperature, ensuring longer component life.
- Rugged lightning protection complies with ANSI/IEEE C62.41-1991 Location Category C2 given in FAA Eng. Brief 67. Category C2 is defined as a 1.2/50 μ S – 8/20 μ S combination wave, with a peak voltage of 10,000 V and a peak current of 5,000 A.
- When turned on, light rise time is low. The light is perfectly adapted for any incursion protection system.
- Optional monitoring function of the individual light source. In case of a defect, the LED light automatically disconnects from the secondary side of the isolation transformer, resulting in an open circuit condition.
- Environment-friendly, precision-cast aluminum alloy top, intermediate and bottom covers.
- Corrosion-resistant stainless steel hardware. Use of Torx screws ensures ease of maintenance.
- For FAA applications, includes a UL 467 rated ground lug, which accepts an AWG 6 earth ground wire

DRC-LP/DTZ-LP lights are part of a complete range of LED in-pavement lights, featuring innovative characteristics, as a leverage for:

Reliability

- Additional watertightness barriers, protecting both the electronics and the LEDs in case of accidental water ingress along the prism or the gaskets as well as along the cables.
- Prisms of small dimensions installed in a deep optical channel with no negative window slope: optimal protection against rubber deposit, scratches and shocks.

Low protrusion without negative slope

- Limited height above pavement of 6.33 mm (0.25 in) reduces the risk of damage during winter operations or by towbarless tugs
- Despite the low protrusion, no part of the prism is below ground level, avoiding loss of photometry during rainfall and sedimentation on the bottom of the prism.

Maintenance friendliness

- Maintenance-friendly: components subject to wear or damage like prisms and cables can easily be replaced. Neither sealing compounds nor resin are required.
- Innovative design of the cable entry, permitting replacement without the need to open the light. This eliminates the risk of water leakage due to a pinched cable.
- Reduced number of components for maintenance simplicity.
- Pressure-release plug for water-tightness testing of fixture after overhaul.

Optional scratch-resistant prisms

- A higher hardness protective layer can be applied to the prism (see Winter Options in ordering code), making it much more resistant to scratches and sand-blasting.

Toe-in Color Coding

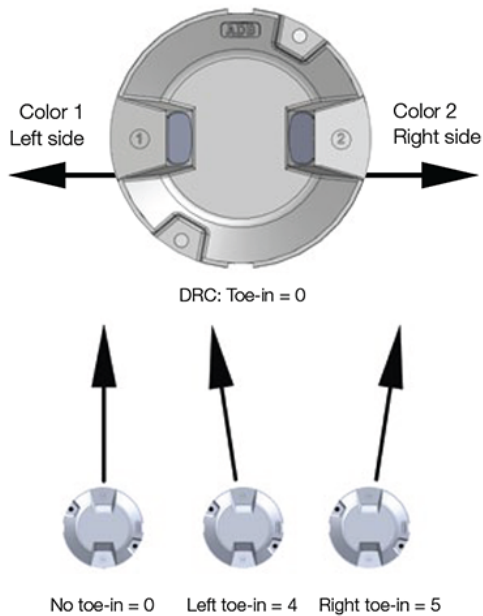

Dimensions

12" Fixture	
Outside diameter	303.3 mm / 11.94 in
Bolt-circle diameter	285.8 mm / 11.25 in
Overall height	78.4 mm / 3.1 in
8" Fixture	
Outside diameter	202 mm / 7.97 in
Bolt-circle diameter	184 mm / 7.24 in
Overall height	78.4 mm / 3.1 in
8" Shallow base	
Outside diameter	230 mm / 9.06 in
Depth	115 mm / 4.53 in

Packaging

12" Fixture	
In cardboard box	177.8 × 330 × 330 mm / 7 × 13 × 13 in
Weight with packing	5.65 kg / 12.45 lb
Weight without packing	5.1 kg / 11.25 lb
8" Fixture	

DRC-LP/DTZ-LP/DFS-LP (Low Protrusion)
LED Runway Centerline and Touchdown Zone In-pavement Light

In cardboard box	177.8 × 330 × 330 mm / 7 × 13 × 13 in
Weight with packing	3.8 kg / 8.45 lb
Weight without packing	3.3 kg / 7.25 lb
8" Fixture with Snow Plow Ring	
In cardboard box	177.8 × 330 × 330 mm / 7 × 13 × 13 in
Weight with packing	18.35 kg / 40.45 lb
Weight without packing	17.8 kg / 39.25 lb
8" Shallow Base	
In cardboard box	230 × 230 × 150 mm / 9.06 × 9.06 × 5.91 in
Weight with packing	2.8 kg / 6.17 lb
Weight without packing	2.6 kg / 5.72 lb

Power Supply

2.8A-6.6 A, through a 20/25 W isolation transformer. DRC-LP / DTZ-LP lights have been designed to work with any IEC- or FAA-compliant transformer up to 100 W without affecting the performances or the lifetime of the light or the transformer. However, using a non-matched transformer will reduce its efficiency.

See data sheet 3033 for more details on recommended isolation transformers.

DRC-LP / L-850A(L)	Fixture Load	Isolation Transformer	Isol. XF Load	CCR Load
Without Heater				
Unidirectional	15 VA	20/25 W	6 VA	21 VA
Bidirectional ¹	33 VA	30/45 W	6 VA	39 VA
Bidirectional ²	20 VA per side	20/25 W per side	6 VA per xfmr	26 VA per side
With Heater				
Unidirectional	33 VA	30/45 W	6 VA	39 VA
Bidirectional ¹	33 VA	30/45 W	6 VA	39 VA
Bidirectional ²	33 VA per side	30/45 W per side	6 VA per xfmr	39 VA per side

Notes

¹ One cord set

² One cord set per side (2 total)

DTZ-LP / L-850B(L)	Fixture Load	Isolation Transformer	Isol. XF Load	CCR Load
Without Heater				
Unidirectional	20 VA	20/25 W	6 VA	26 VA
With Heater				
Unidirectional	32 VA	30/45 W	6 VA	38 VA

3.0 Installation



WARNING

Read the instructions in their entirety before starting installation.

This section provides installation instructions for the DRC-LP and the DTZ-LP, LED light fixtures.

This section provides instructions for installing the in-pavement lights. Refer to airport project plans and specifications for specific installation instructions. The installation must conform to the applicable sections of the National Electric Code and local codes.

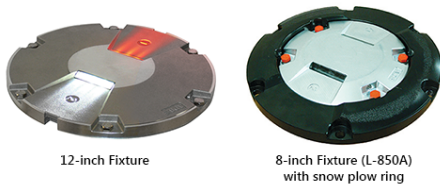

12-inch Fixture

8-inch Fixture (L-850A)
with snow plow ring

3.1 Installation Overview

On a shallow base.

The 8" dia. base is secured in the pavement by means of resin. Correct positioning and leveling are obtained with a jig with sighting telescope. Wires between the light and the series transformer are installed either in saw cuts in the pavement filled with resin or in pipes in the lower concrete layers. Mounting on existing or new, larger diameter bases, is made possible by means of dedicated adapter rings.

Figure 1: Installation on 8" shallow base

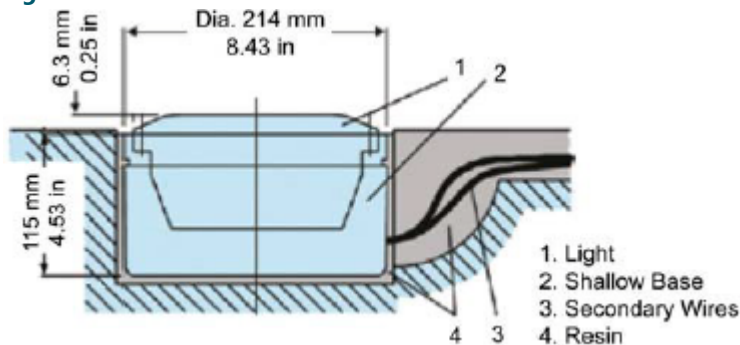

On a FAA L-868B size B steel base.

The 8" dia. light is mounted in an 8" to 12" dia. snow plow or adapter ring bolted onto the base. The 12" fixture is directly mounted without a separate ring. The bases are interconnected by means of conduits protecting the cables. See FAA AC 150/5340-30 for additional design guidance on deep base cans. The series transformer is installed under the light or in a separate pit. See data sheet A.05.120 or DS2012 for more information on base cans.

3.2 INTEROPERABILITY

Top cover versions



Note

Please check interoperability matrix for information on torque values and compatibility towards different bases.

3.3 Typical L-868 Assembly

Figure 2: Diagram of the Fixture Installed in a 1-Piece Base Can

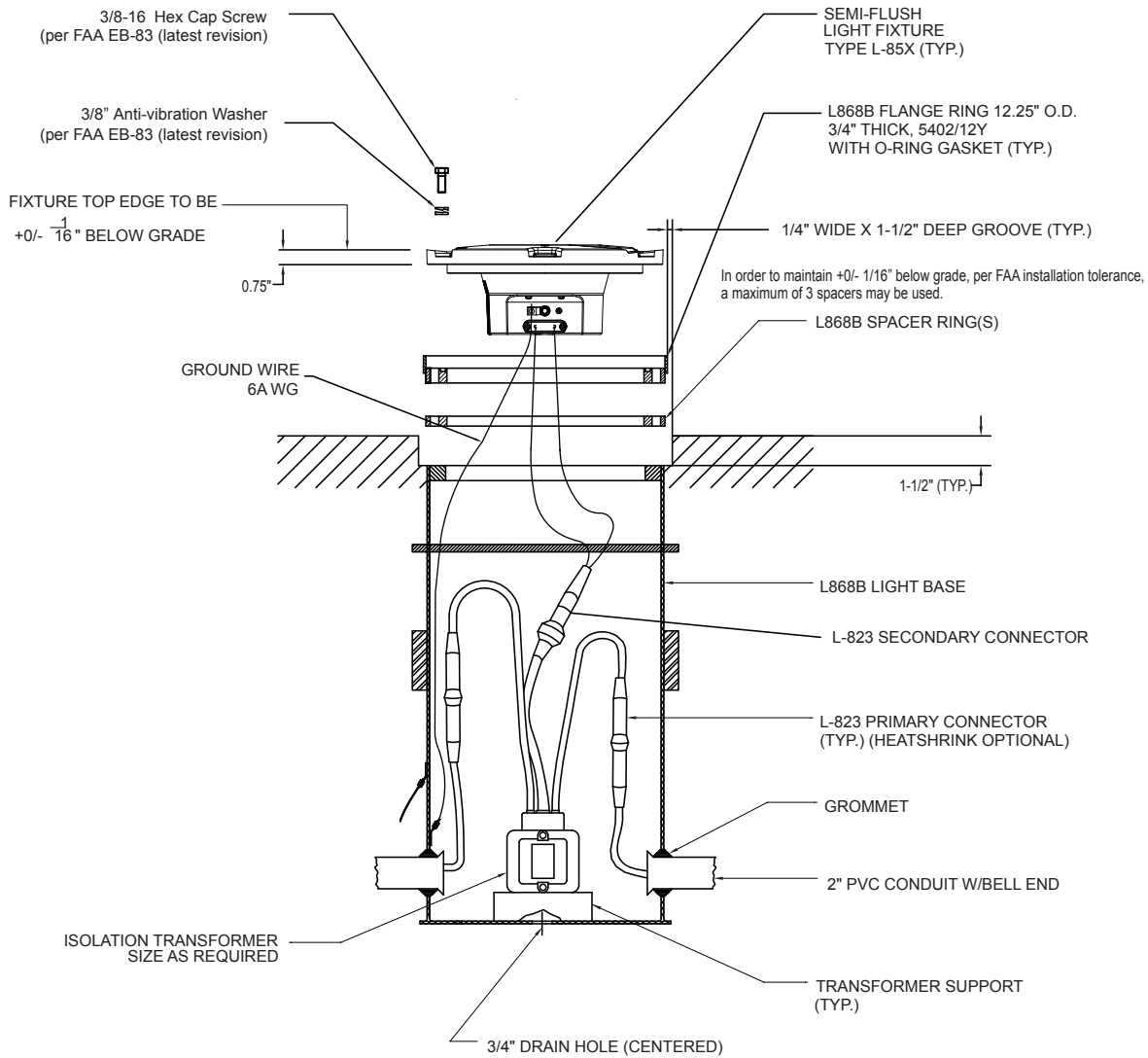

1. Torque according to: FAA EB-83 (latest revision).

Figure 3: Anti-vibration washer example

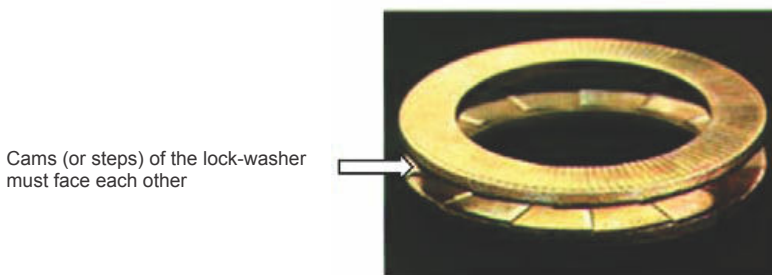

Cams (or steps) of the lock-washer must face each other



CAUTION

Per FAA AC 150/5340-30, Chapter 10, and FAA Engineering Brief No 83 (latest revision), it is extremely important that other types of washers, such as split washers, must not be used. Failure to use properly installed anti-vibration lock washers will cause mounting bolts to become loose. The cams (or steps) of each half of the lock washer must face each other.

3.4 Safety Considerations

Read the installation section of all system component manuals before starting these steps. A thorough understanding of system components and their requirements will promote safe and efficient installation. See FAA AC 150/5340-30, Design and Installation Details for Airport Visual Aids, and site plans and specifications for field installation of runway and taxiway in-pavement lights.



DANGER

Failure to follow these safety procedures can result in personal injury or death.

- Allow only qualified personnel to install ADB SAFEGATE and auxiliary equipment. Use only approved equipment. Using unapproved equipment in an approved system may void FAA approvals. Observe and follow the safety instructions in this document and all other related documentation.
- Make sure all equipment is rated and approved for the environment where it is being used.
- Follow all instructions for installing components and accessories.
- Install all electrical connections in compliance with local and national codes and regulations.
- Use only electrical wire of sufficient gauge and insulation to handle the rated current demand. All wiring must meet local and national codes.
- Route electrical wiring along a protected path. Make sure it will not be damaged by moving equipment.
- Protect components from damage, wear and harsh environmental conditions.
- Allow ample clearance for maintenance, panel accessibility and cover removal.
- Protect equipment with safety devices as specified by applicable safety regulations.
- If safety devices must be removed for installation, reinstall them immediately after the work is completed and check them for proper functioning.
- The cord set must be protected prior to installation.

3.5 Photobiological safety



CAUTION

Photobiological safety conforming with IEC 62471

RISK GROUP 0 or 1: Optical radiation emitted from LED lights may be harmful to the eyes. Do not stare with the light source with bare eyes at a fixture operating at high intensity. Use protection goggles or similar protection method.

Goggles with a transmission factor not higher than 5% in the 400-530 nm band have been tested and provide adequate protection.

3.6 Verify Input Requirements and Equipment Needed

The In-pavement light fixture is designed for connection to a 6.6A or 20A series lighting circuit via an L-830 (60 Hz) or L-831 (50 Hz) isolation transformer.

Make sure you have the necessary tools and materials ready for installation (not supplied). Also consider other tools that might be needed based on site-specific conditions.

Table 1: Suggested Tools and Materials for Installation and Repair

Qty.	Description	Qty.	Description
1	Torque wrench	1	Set of screwdrivers, one with 3/8" (9.525mm) minimum blade width
1	Alignment jig		
1	Diamond-faced core drill	As needed	Silicone grease
1	Diamond-faced saw, 3/8" (9.525mm) thick	As needed	Joint sealing filler
1	Crimping tool	1	Pressure test fitting assembly
1	Small water suction pump	As needed	Dow Corning Molykote® 3452 or equal (P/N 67A0095) - used on top cover prism seal
2	Eyebolts, 3/8 inch (9.525mm) diameter		
1	Lifting rod, 16 inches (406mm) long	As needed	Novagard® Silicone Versilube® G322L™ (P/N 67A0009) - used on O-ring between top cover and inner pan assembly; also may be applied to four nipples of inner pan assembly to install optical assembly
1 or 2	L-830 / L-831 isolation transformer		
1	Set of fiber brushes		
1	Set of socket wrenches, 1/2" (12.7mm) drive		

3.7 Unpacking the Unit

To reduce the possibility of damaging the light assembly, unpack the RELIANCE light fixtures at the installation site. If damage to any equipment is noted, file a claim form with the carrier immediately.

When receiving the light fixture, open the box and verify that the characteristics of the light fixture correspond to the design requirements, such as type, color etc. When installing an IQ0 light fixture where the function is to be activated at a later stage, make sure to register product information, such as PID/SN and position of the light fixture in, for example, a site documentation table. The information is required for remote activation and administration of IQ functionality from a substation.

3.8 Inspect on delivery

1. Inspect all packings for visible damage.
2. Open every damaged box and inspect the contents for damage.
3. Immediately fill a claim form with the carrier if any fixture is damaged.
4. Store the fixture in its original packing in a protected area.



Note

If damage to any equipment is noted, file a claim form with the carrier immediately.



WARNING

Do not damage the cable insulation.



CAUTION

Do not unpack the fixture before it is at the installation site to avoid damage due to transportation and handling.

3.9 Store

Store the fixture in its original packing in a protected area. Indoor storage:

- Storage temperature: 14°F to 122°F (-10°C to +50°C).
- Humidity: <95% non condensing.

For long storage periods (longer than one year), we recommend to energize the LED lights once a year at nominal intensity (6.6 Amps) for 20 minutes.

3.10 Toe-in Location Only

Make sure the ADB logo (A) points towards the runway centerline.

Figure 4: DTZ-LP Toe-in Diagram

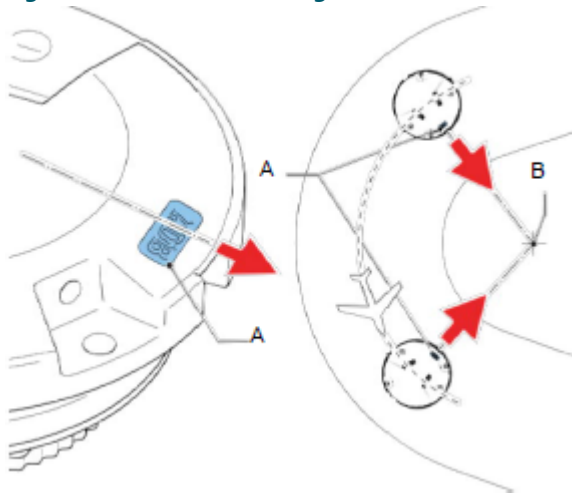

3.11 Installation on L-868 Base

The light assembly is shipped complete, and is ready for installation.

To install the fixture on an L-868 base, see FAA AC 150/5345-30 and the project site-specific plans and specifications for details on L-868 base installation.

i Note

Mounting bolts are not supplied with the fixture. Mounting bolts and anti-rotation lock washers are normally supplied with the base can spacer or flange ring. If a flange ring is used, the bolt length is 1-1/4 inch (32mm) plus the thickness of the flange ring.

Also read the following guidelines:

1. Clean the base receptacle. Make sure the base receptacle is completely clean and dry. The mating surfaces must be clean and free of foreign particles.
2. If, present, fit an appropriate lifting tool into the two threaded holes, which are located 180° apart in the cover.



The lifting tool can be made from two 1/2 x 13 eyebolts (1-inch ID) and a 1/2-inch diameter, 16-inch (406mm) long rod or pipe inserted through the eyebolts.

**CAUTION**

Never hold the light fixture by the wires. Doing so may damage the insulation, break the waterproof seal and cause insulation faults and water leakage.

3. Carry the light assembly to the base.
4. Place the light assembly next to the opening in the L-868 base so that the L-823 connector can be connected with the mating receptacle from the L-830 or L-831 isolation transformer in the base. Make sure that the connection is solid and secure. Refer to the Electrical Supply section of the User manual for required isolation transformers.
5. Make sure items such as spacers, shims and gaskets are installed on the light base as indicated on site plans, specifications and drawings.
6. Position the light assembly over the L-868 base and set it onto the base. Align the light according to FAA AC 150/5345-30 and project plans and specifications. Remove the eyebolts and lifting rod.

**CAUTION**

Ensure that the cord set wires are NOT pinched between the base can and the fixture. Pinched wires can cause water to be drawn inside the fixture.

7. If present, lubricate the labyrinth gasket with water. soap may be added to the water (8" only).

**CAUTION**

Do not use silicon or any other type of grease. Avoid the use of soap that contains silicon or glycerin.

8. Attach the six fixing bolts and anti-vibration washers. [See FAA EB-83 (latest revision)]

**CAUTION**

Due to the risk of bolts vibrating loose, do not use any type of washer with the fixing bolts (such as split lock washers) other than an anti-vibration washer. Anti-vibration washers as defined in FAA EB-83 (latest revision).

9. Turn on the power to determine whether the fixture will illuminate. Operate for a minimum of five minutes.

3.12 Torquing and Installation Guidance for In-pavement Fixtures

In-pavement fixtures must be installed according to the plans and specifications; the applicable regulatory guidance; and the following guidance. The importance of using the proper fixture clamping components and bolt torque to minimize the risk for fixture failure or loosening of clamping components cannot be overemphasized. Refer to FAA Engineering Brief No 83 (latest revision) for torque and installation guidelines for this fixture.

Also see our Product Center at www.adbsafegate.com.

**CAUTION**

Read installation instructions in their entirety before starting installation.

- Failure to follow the installation guidance could result in bolt loosening or bolts breaking off, resulting in catastrophic failure of the fixture and/or the mounting system components.
- Failure to follow these warnings may result in serious injury or equipment damage.

3.13 Shallow base can installation

Shallow base cans may be non-load bearing or load bearing depending on location or fixture application. Following are specific requirements to insure that an either an elevated or an in-pavement fixture is properly installed.



CAUTION

Read installation instructions in their entirety before starting installation.

Fasteners:

- Make sure the power is OFF when you install or remove any fixture.
- Only use fasteners of the same type as the one originally supplied with the mounting support. See Base O-ring and Bolt Selection.
- Always tighten the fasteners to the recommended torque. Use a calibrated torque wrench and apply the recommended adhesive type.
- If this is not the case, this may cause the fasteners to loosen, damage the fixture, potentially to loosen the fixture. This can lead to a highly dangerous situation of FOD, with potential lethal consequences.
- Obey the instructions of the adhesives necessary for the fasteners.
- Only install the fixture on mounting supports:
 - That ADB Safegate has approved;
 - That are installed according to the Instruction Manual of the mounting support.
- Failure to do so can result in a highly dangerous situation of FOD, with potential lethal consequences.

Failure to follow these warnings may result in serious injury or equipment damage.



CAUTION

Proper Operation:

- The fixture is supplied from a 6.6 A series circuit;
- The series circuit is powered by a Constant Current Regulator that complies with IEC 61822;
- The transformer is an AGL series transformer that complies with IEC 61823.
- The power of the series transformer shall not exceed 200 W, for versions with the monitoring option.
- The mounting support is correctly earthed. Failure to do so will void the warranty for all damages that occur as a result of voltage surges.
- Never hold the fixture by the cable leads. This can damage the insulation, break the waterproof seal and cause insulation faults and water leakage.



Note

See the Instruction Manual of the mounting support for instructions on how to earth the mounting support.

3.13.1 Installation on a Shallow Base

Installing the light fixture on a shallow base involves preparing the pavement recess and wireways, then installing the light fixture on a shallow base.

See FAA AC 150/5345-30 and the project site-specific plans and specifications for details on shallow base installation.

Also follow the applicable instructions in the previous section, when connecting, installing and powering the fixture.

Figure 5: Example of a Shallow Base Installation

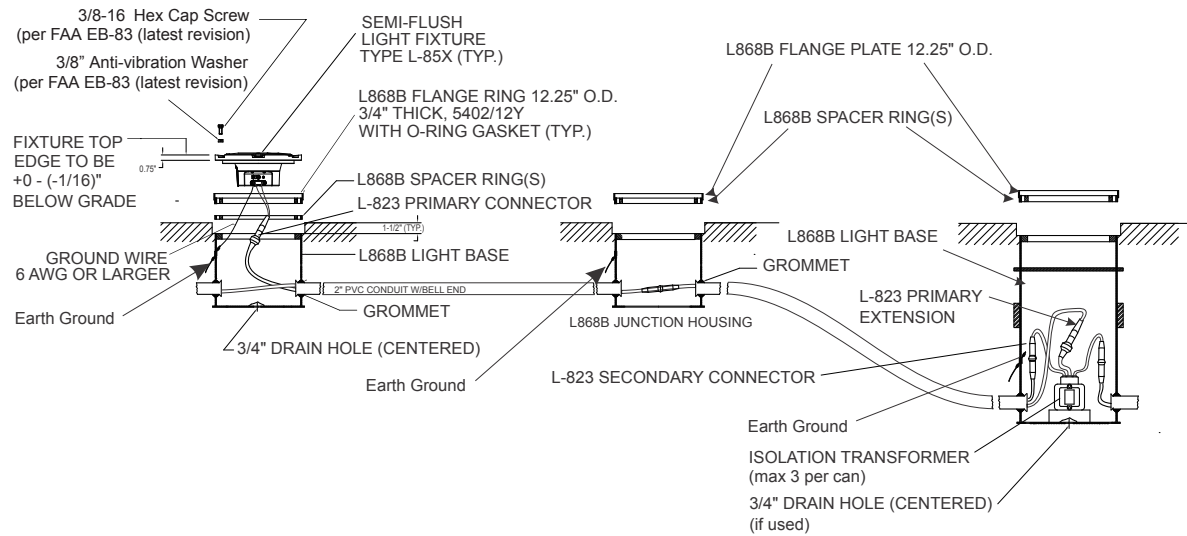

1. Torque according to: FAA EB-83 (latest revision).

Figure 6: Anti-vibration washer example

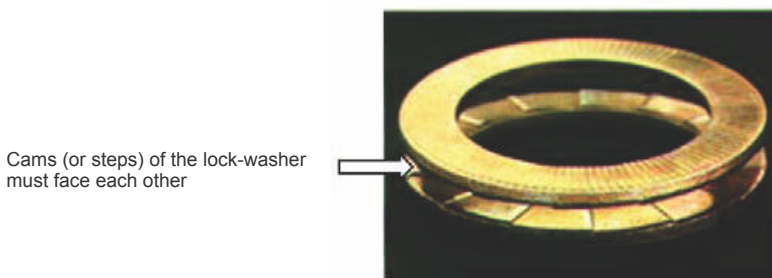

CAUTION

Per FAA AC 150/5340-30, Chapter 10, and FAA Engineering Brief No 83 (latest revision), it is extremely important that other types of washers, such as split washers, must not be used. Failure to use properly installed anti-vibration lock washers will cause mounting bolts to become loose. The cams (or steps) of each half of the lock washer must face each other.

4.0 Maintenance



CAUTION

Read the instructions in their entirety before starting installation.

4.1 Safety Considerations

Read the installation section of all system component manuals before starting these steps. A thorough understanding of system components and their requirements will promote safe and efficient installation. See FAA AC 150/5340-30, Design and Installation Details for Airport Visual Aids, and site plans and specifications for field installation of runway and taxiway in-pavement lights.



DANGER

Failure to follow these safety procedures can result in personal injury or death.

- Allow only qualified personnel to install ADB SAFEGATE and auxiliary equipment. Use only approved equipment. Using unapproved equipment in an approved system may void FAA approvals. Observe and follow the safety instructions in this document and all other related documentation.
 - Make sure all equipment is rated and approved for the environment where it is being used.
 - Follow all instructions for installing components and accessories.
 - Install all electrical connections in compliance with local and national codes and regulations.
 - Use only electrical wire of sufficient gauge and insulation to handle the rated current demand. All wiring must meet local and national codes.
 - Route electrical wiring along a protected path. Make sure it will not be damaged by moving equipment.
 - Protect components from damage, wear and harsh environmental conditions.
 - Allow ample clearance for maintenance, panel accessibility and cover removal.
 - Protect equipment with safety devices as specified by applicable safety regulations.
 - If safety devices must be removed for installation, reinstall them immediately after the work is completed and check them for proper functioning.
 - The cord set must be protected prior to installation.
-

4.2 Maintenance

This section provides maintenance information and procedures for the F-Range light fixtures.

Preventive Maintenance - Inset Lights

Maintenance personnel must refer to the maintenance procedure described in the ICAO Airport Services Manual, Part 9, Airport maintenance practices and in FAA Advisory Circular N° AC150/ 5340-26.



DANGER

Electric Shock Hazard

This equipment may contain electrostatic devices

- Do not carry out any action on the fixture unless you have read and understood all the information in the Safety Section.
- Do not operate a system that contains malfunctioning components.
- If a component malfunctions, turn the system OFF immediately.
- Disconnect and lock out electrical power.
- Allow only qualified personnel to make repairs. Repair or replace the malfunctioning component according to instructions provided in its manual.
- Make sure that the power to the series circuit is OFF when you carry out maintenance.

Failure to follow these instructions can result in death or equipment damage



CAUTION

Use of incorrect combination of gaskets, bolts and nuts can create severe damages to the product installation and create multiple safety risks.

To obtain a safe and watertight installation the O-ring and retaining bolt stated in the document must be used.

You need to know what base the light fixture will be installed in, in order to choose the correct gasket, bolts and nuts.

Failure to follow these cautions can result in equipment damage or aircraft FOD.

4.3 Removing L-868 Base Water



CAUTION

Turn off the circuit when checking the water level.

If consistent with airport practice, check the water level in the L-868 base on a regular schedule. If more than six inches (150 mm) of water in the light base is found, pump the water from the base and remove and inspect the entire light assembly for water damage. Cover the L-868 base with the appropriate steel cover plate after removing the light assembly.



Note

Water entering the L-868 base can become a serious problem, since freezing water can rupture the base.

4.4 Lifting Optical Unit Out of Base

To lift the optical unit from the light base, perform the following procedure:

1. Remove the six fixing screws and washers or self locking nuts.
2. Fit the appropriate lifting tool into both threaded holes located (180 degrees apart) in the cover, lift the optical unit out of the base and place the optical unit next to the base.
3. Disconnect the light fixture wires from the power wires coming from the transformer(s).

4. Mount a serviced or new light fixture as described in Installation on L-868 Base in the Installation section.
5. Take the in-pavement fixture unit back to the maintenance base where it can be serviced entirely.



CAUTION

Never hold the light fixture by the wires. This may damage the insulation, break the waterproof seal, and cause insulation faults and water leakage.

4.5 Repair Procedures

4.5.1 Opening the Optical Unit

To open the optical unit, perform the following procedure:

1. Remove the pressure release screw.
2. Dispose of the gasket of the pressure release screw.
3. Remove the inner cover screws.
4. Dispose of the inner cover screws.
5. Remove the upper cover assy.



Note

Put a screwdriver in the notches.

6. Remove the gasket.
7. Dispose of the gasket.

Figure 7: Disassemble the Light Unit

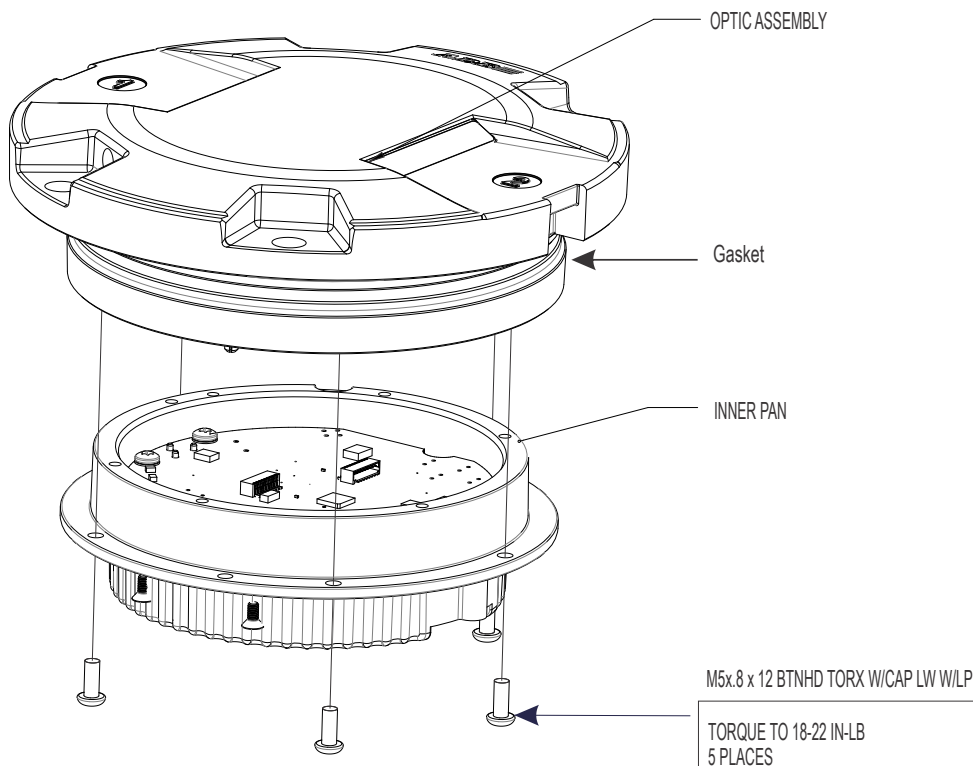

4.5.2 Removing the LED Assembly

1. Turn the top cover assembly over.
2. Remove the LED Assembly pressure release screw.
3. Remove the four screws attaching the LED assembly to the top cover assembly.



Note

The optical assembly is connected to the PCB. If you pull too hard, you can damage the PCB. Disconnect the wires carefully.

4. Remove and dispose of the gasket.

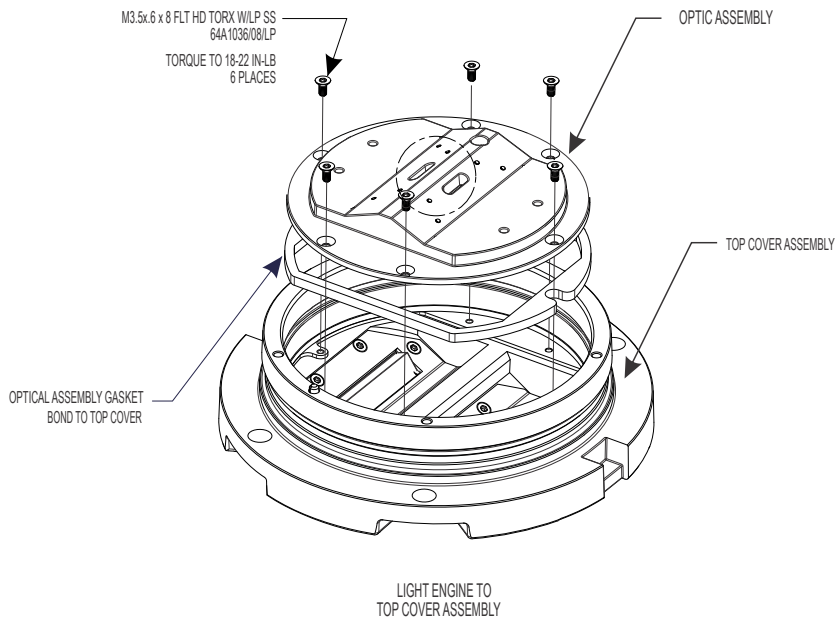

4.5.3 Cleaning the Light Channel and Prism

To clean the light channel and prism, perform the following procedure:

1. Remove the four screws of the prism retaining bracket. Gently remove the prism and the prism seal.
2. Use a suitable fiber brush to remove all accumulated debris from the light channel.
3. Clean the outer surface of the prism using liquid glass cleaner. If the prism is coated with a substance impervious to the cleaner, apply a suitable solvent sparingly with a wad of cotton or a patch of cloth. After the solvent has acted, remove the softened coating with a clean piece of cotton or cloth. Dry the prism gently with dry, oil-free compressed air at a pressure no greater than 10 psi (69 kPa) to evaporate or remove all remaining cleaner.
4. If the prism is damaged go to the next procedure.

4.5.4 Replace the fuse resistor (monitoring option)

Parts

- Fuse resistor kit.

Item	Description	Version	Part Number
A	Fuse resistor (available as a kit containing 20 resistors)	Monitoring option	6132.00.250

Tools

- Pliers



Note

Bidirectional lights have two fuse resistors. Unidirectional lights have only one fuse resistor.



Note

Fuse resistors are located on the PCB of the inner cover assembly. (A) Always replace all fuse resistors located on the PCB.

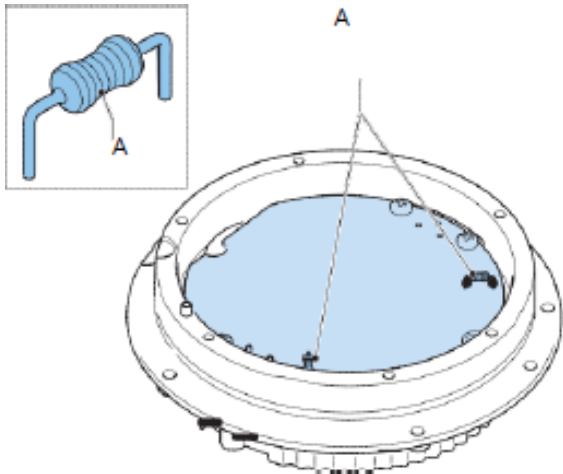

Disassemble

1. Remove the fuse resistor(s) (A) by pulling the legs of the fuse resistor.
2. Test the fuse resistor with an OHM-Meter. A faulty fuse resistor will show open.
3. Dispose of the old fuse resistor/s.
4. Take the new fuse resistor/s from the kit.
5. Place the new fuse resistor in the socket.

Assemble

Insert the legs of the new fuse resistor in the socket and press into place. Proceed to: "[Closing the Optical Unit](#)".

4.5.5 Replacing Prism

Replace the prism if it is broken or its surface is badly pitted or scarred.



CAUTION

Always dispose of the gaskets and the screws when you disassemble the prism.

To replace the prism, perform the following procedure:

Prism Removal

1. Remove the upper cover assembly. See "[Opening the Optical Unit](#)".
2. Remove the LED Assembly Following the steps above.
3. Remove the prism screws.

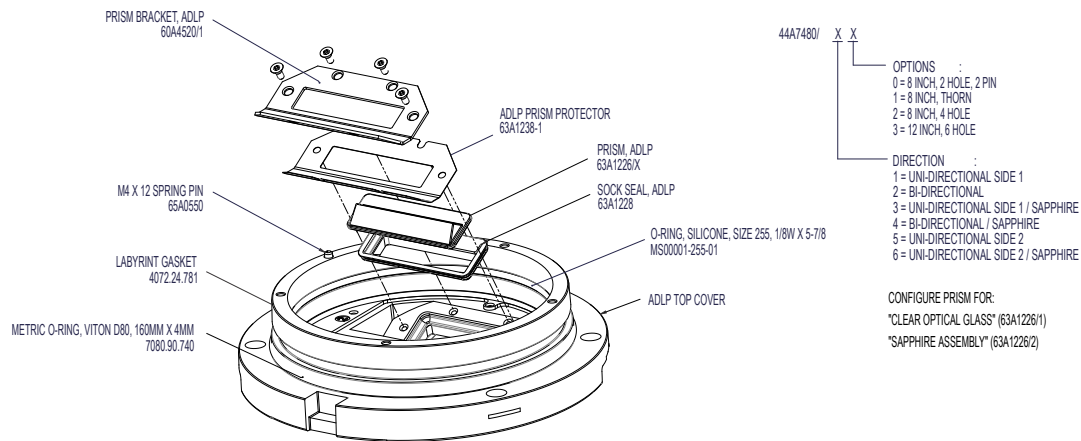

4. Dispose of the prism screws.
5. Remove the prism bracket.
6. Remove the prism.
7. Remove the prism gasket.
8. Dispose of the prism gasket.

Replace the Prism

Prepare

9. Make sure that all parts are clean.
10. Pay special attention to the parts where the gasket must fit.

Assemble prism

11. Install a new prism gasket.
12. Install a new prism. Tilt the prism a little and press the prism firmly.
13. Make sure the prism and the prism gasket are correctly in position. If it is not the case re-install the new prism and prism gasket.
14. Make sure you installed the correct prism and prism gasket.
15. Clean the surface of the new prism with a methanol moist cloth.
16. Install the prism bracket.
17. Install but do not tighten the new prism screws.
18. Tighten the prism screws crosswise. See " [Fastener Torque Table](#)".
19. Install the upper cover assembly. See " [Fastener Torque Table](#)".

4.5.6 Replace cable lead

Figure 8: Disassemble the Cord Set

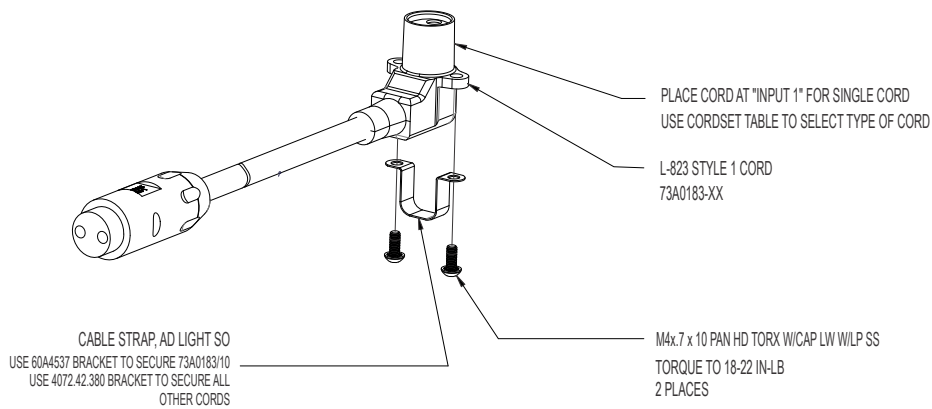

1. Remove the cable screws.
2. Dispose of the cable screws.
3. Remove the cable.

Assemble the Cord Set

4. Install the new cable.
5. Install the new cable screws. See " [Fastener Torque Table](#)".

4.5.7 Replace labyrinth gasket (8" only)



Note

Always dispose of the labyrinth gasket when you remove the fixture from the mounting support.

Remove the Labyrinth Gasket

1. Remove the labyrinth gasket (A).
2. Dispose of the labyrinth gasket.

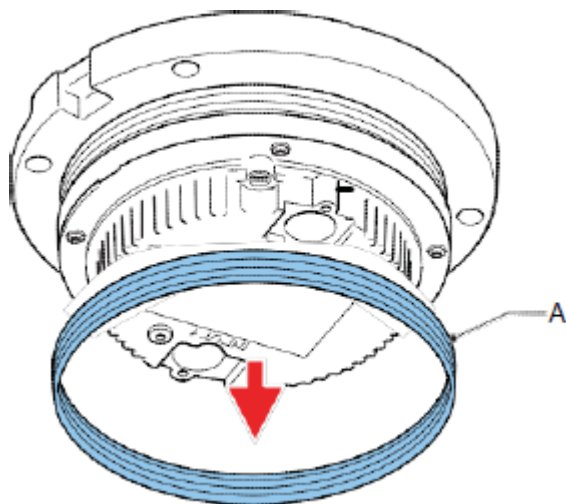

Install the new Labyrinth Gasket

3. Make sure that all parts are clean.
4. Inspect and clean the part where the labyrinth gasket must fit (A).

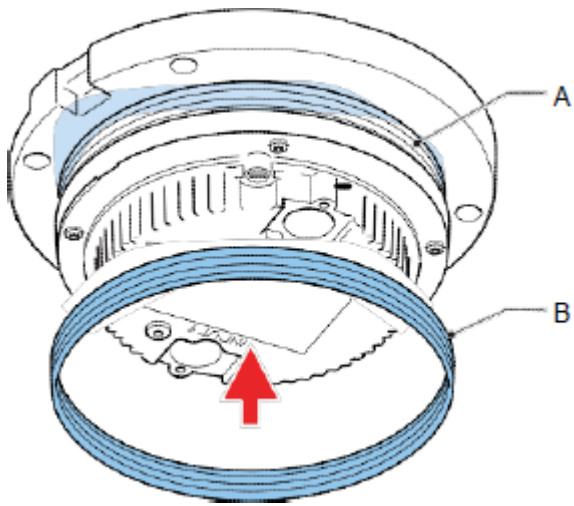

5. Install the new labyrinth gasket (B).

4.5.8 Closing the Optical Unit

1. Make sure that all parts are clean.
2. Pay special attention to the parts where the gasket must fit.

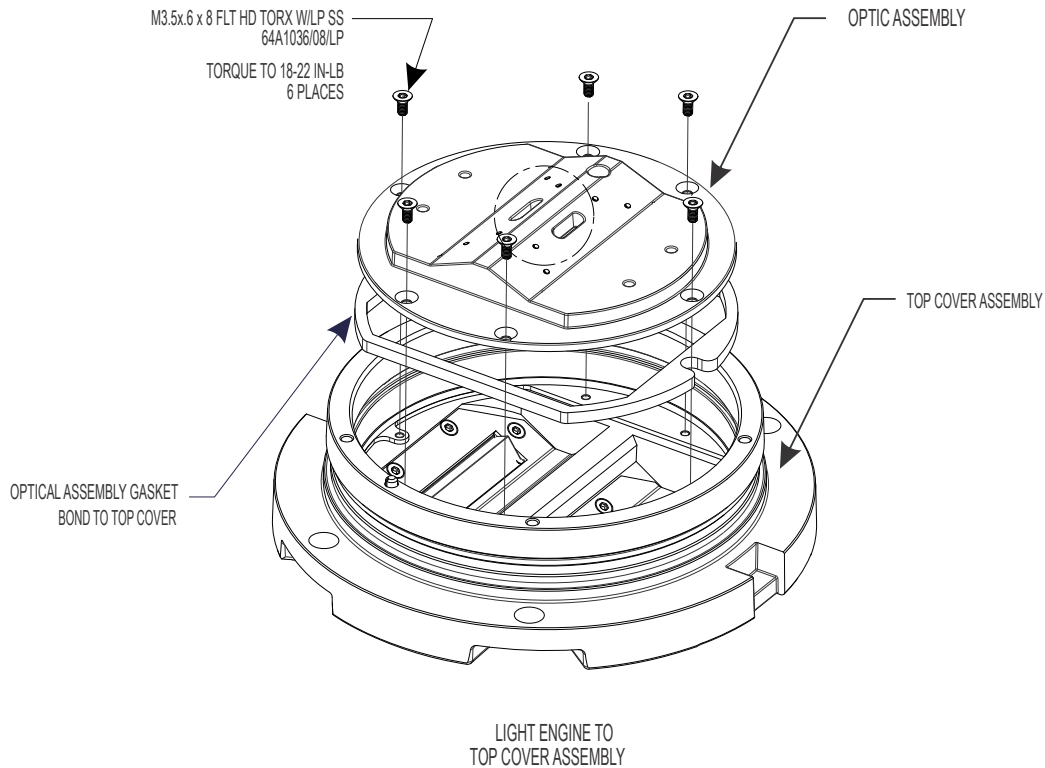

3. Install the LED Assembly using the four screws.



Note

Make sure that the locating pin is set to the hole marked '0' of the optical assembly.

4. Connect the wires to the PCB. INPUT 1 and INPUT 2 are labeled underneath the connector. When you have an unidirectional light, connect the optical assembly to connector INPUT1
5. Lubricate the new gasket of the pressure release screw. Use lubricant A.
6. Install a new gasket on the pressure release screw.
7. Install the pressure release screw.

Assemble the Light Unit

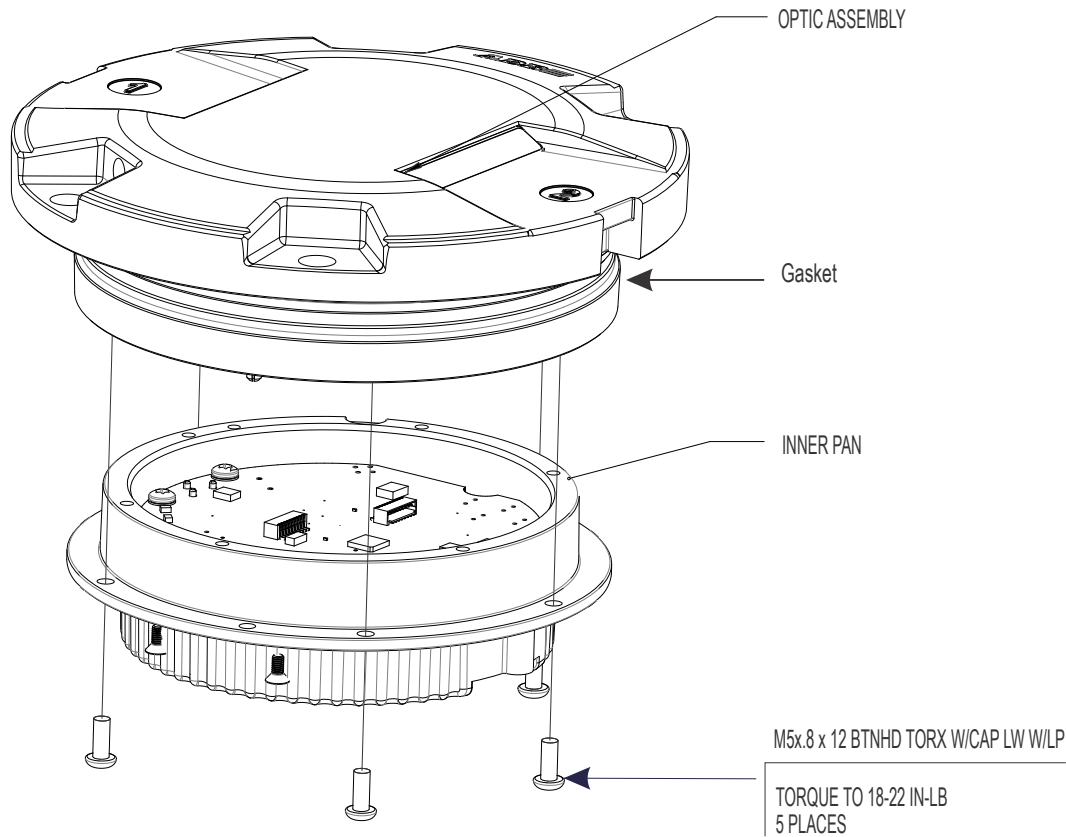

8. Lubricate the new gaskets. Use lubricant A. See “ [Adhesives and Lubricants](#)”.

- Gasket;
- Gasket of the pressure release screw;

9. Install the new gasket.

10. Install the upper cover assembly.

11. Install the new inner cover screws (C). See “ [Fastener Torque Table](#)”.

12. Carry out a waterproof test. See “ [Testing for Leaks](#)”.

13. Install the new gasket of the pressure release screw.

14. Install the pressure release screw. See “ [Fastener Torque Table](#)”.

4.5.9 Fastener Torque Table

Table 2: Fastener Torque

Screw Type	Name	Details	Part Number	Torque in-lbs. (N·m)
G	Prism screws	Screw M5x14	7100.10.211	35 (4.0)
J	Optical assy screws	Screw M4x10	7100.10.101	22 (2.5)
M	Inner cover screws	Screw M5x14	7100.10.211	31 (3.5)
N	Pressure release screw assy	Assy (screw + gasket)	4072.24.940	22 (2.5)
		Gasket only	7080.90.012	
P	Cable lead screws	Screw M4x10	7100.10.101	22 (2.5)

4.5.10 Adhesives and Lubricants

Table 3: Adhesives

Adhesive A	Loctite 2701 (follow manufacturer's instructions)	7870.05.130
Adhesive B	Loctite 222 (follow manufacturer's instructions)	7870.05.140
Adhesive C	Loctite 638 (follow manufacturer's instructions)	7870.05.097
Adhesive D	Loctite 243 (follow manufacturer's instructions)	7870.05.160

Table 4: Lubricants

	Vacuum silicone grease (50 g) to install O-ring gaskets (follow manufacturer's instructions)	7850.42.220
Lubricant A	Novagard® Silicones Versilube® G322L™ <ul style="list-style-type: none"> used on O-ring between top cover and inner pan assembly; also may be applied to four nipples of inner pan assembly to install optical assembly 	67A0009
	Molykote HP870 Inerta (100 g) to replace prism (follow manufacturer's instructions)	7850.05.061
Lubricant B	Dow Corning Molykote® 3452 or equal <ul style="list-style-type: none"> used on top cover prism seal 	67A0095

4.5.11 Testing for Leaks

To test for leaks, perform the following procedure:

1. See [Figure 9](#).

Remove pressure relief screw.

2. See [Figure 10](#).

Screw pressure test fitting into the pressure relief port (the opening created when the pressure relief screw is removed). Screw fitting hand-tight.

Figure 9: Pressure Relief Screw



Figure 10: Pressure Test Fitting Assembly

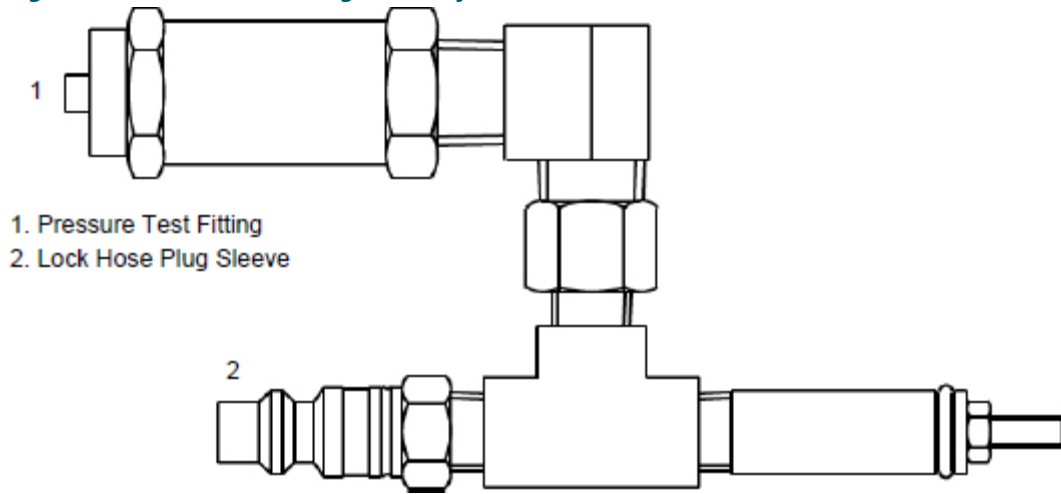

3. Attach the shop airline to the lock hose plug sleeve (2).
 4. Pressurize to 20 psi.
 5. Submerge the pressure test fitting in a water tank.
Check for air bubbles. Air bubbles indicate a leak.
 6. Locate the leak source, depressurize, replace the seal that is leaking, reassemble, and retest by following steps 4 and 5.
If leak is fixed, depressurize and reinstall the pressure release screw (1).
- Go to [Installation](#) to finish.

4.6 Material Handling Precautions: Fasteners



DANGER

Foreign Object Damage - FOD

This equipment may contain fasteners that may come loose - torque properly.

- Only use fasteners of the same type as the one originally supplied with the equipment.
- Use of incorrect combination of gaskets, bolts and nuts can create severe damages to the product installation and create safety risk .
- You need to know what base the light fixture will be installed in, in order to chose the correct gasket, bolts and nuts.
- Bolt type, length, and torque value are determined by type of base, height of spacers used, and clamp force required in FAA Engineering Brief No 83 (latest revision).
- Due to the risk of bolts vibrating loose, do not use any type of washer with the fixing bolts (such as split lock washers) other than an anti-vibration washer. Anti-vibration washers as defined in FAA EB 83 (latest edition) must be used. For installations other than FAA, use the base can manufacturer's recommendations.
- Always tighten the fasteners to the recommended torque. Use a calibrated torque wrench and apply the recommended adhesive type.
- Obey the instructions of the adhesives necessary for the fasteners.

Failure to follow these warnings may cause the fasteners to loosen, damage the equipment, potentially to loosen the equipment. This can lead to a highly dangerous situation of FOD, with potential lethal consequences.



Note

To minimize the risk of errors, the ADB SAFEGATE Sales Representative will have information on which gasket goes with which base. This information is also provided in the product Data sheets, the User Manuals and the Spare Part Lists.



CAUTION

Use of incorrect combination of gaskets, bolts and nuts can create severe damages to the product installation and create multiple safety risks.

To obtain a safe and watertight installation the O-ring and retaining bolt stated in the document must be used.

You need to know what base the light fixture will be installed in, in order to choose the correct gasket, bolts and nuts.

Failure to follow these cautions can result in equipment damage or aircraft FOD.

4.7 Bolt Torque Preventive Maintenance Schedule

An established schedule for checking light fixture bolt torque and bolt condition is mandatory. This is particularly true for areas that are subject to high impact loads from aircraft such as runway status lights, runway touchdown zone lights, runway centerline lights, and taxiway lead-off lights. Although AC 150/5340-26 offers a recommended schedule for periodic checks, these checks should be tailored to the facility based on local conditions such as environmental issues and runway traffic load.

1. Torque according to: FAA Engineering Brief No 83 (latest revision).

Figure 11: Anti-vibration washer example

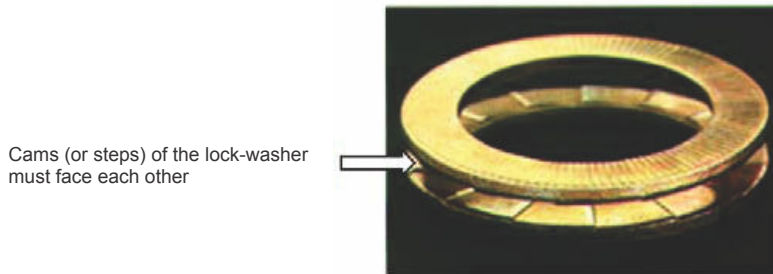

CAUTION

Per FAA AC 150/5340-30, Chapter 10, and FAA Engineering Brief No 83 (latest revision), it is extremely important that other types of washers, such as split washers, must not be used. Failure to use properly installed anti-vibration lock washers will cause mounting bolts to become loose. The cams (or steps) of each half of the lock washer must face each other.

FAA Cert Alert No. 14-03 refers to AC 150/5340-26 for the frequency of checking bolt torque. AC 150/5340-26 (latest revision) paragraph 5.3.4.1.4, *Bi-Monthly Checks* states: "The torque of the bolts attaching the light fixture to its base should be checked with a calibrated torque wrench – never use an impact wrench."

Regular inspection as outlined in FAA Engineering Brief 83 (latest edition), Canada Civil Aviation Safety Alert Document CASA 2014-05, and any other applicable regulatory guidelines is critical in insuring torque on all bolts is restored to optimum values. Bolts that loosen more often should be inspected and re-torqued on a more frequent basis.

It is especially important to maintain a regular inspection schedule for LED fixtures. Since LED fixtures operate more reliably and are not subject to removal/replacement/re-torque as frequently as would be seen with incandescent fixtures, it is even more important to implement regular torque inspections.

It is critical that remedial action be taken if bolts are found to be loose or missing during inspection. If this occurs, it is important to carefully inspect all structural elements of the mounting system as defined in Installation. Also inspect the base can for general structural conditions such as:

- Is the base can solidly mounted in the pavement, and not moving or rocking during rollovers?
- If a base can extension is present, are all extension attachment bolts tight?

If poor base can structure or mounting system components are not in accordance with regulatory requirements or are in poor condition, it is the airport's responsibility to:

- Increase the frequency of bolt torque inspection to insure that no bolts become loose or missing.
- Quickly replace/repair the mounting system components, which may include replacing the entire base can.

Airport operators must also ensure these maintenance activities are properly documented.

Digital Asset Tracking and Service Application Information

ALIS is ADB SAFEGATE's new digital asset tracking, inspection and service solution, helps airports easily register airside assets, electronically schedule and track maintenance, and record maintenance and inspection tasks in compliance with ICAO and FAA standards.

Easy to implement and use, cloud-based software enables a more reliable and fail-safe approach to asset tracking and maintenance by always using live field data and eliminating inefficiencies caused by human error. Every asset is registered using GPS data and its status recorded, so airport maintenance teams get a clearer view of maintenance schedules and history, allowing them to manage resources more effectively as well as improve the safety and longevity of airside assets. This increased visibility helps airports plan and schedule preventive maintenance, or undertake corrective maintenance more quickly, to reduce downtime and significantly improve operational availability.

<https://adbsafegate.com/product-center/airfield/airside-services/ALIS-airside-maintenance>

- Easily integrates electronic torque measurements and photometric measurement reports to provide a complete view of the asset's status.
- ALIS can be integrated with the AirTorque or Ingersoll Rand® QX series wrenches, which are used for accurate, ergonomic torque inspections of AGL fixtures. The applied torque can seamlessly be registered in the ALIS system as a part of the maintenance record.
- The iPhone application of ALIS – ALIS Personal – makes it easier than ever to register maintenance actions while working. It will proactively show you which assets you still need to work on and select the closest one to you automatically. ALIS Personal acts as a feedback and information device for the associated torque wrench.

5.0 Troubleshooting

Table 5: Troubleshooting Guide

Problem	Possible cause	Possible solution
No light or light flickers	Connection to the input power has a malfunction.	<ul style="list-style-type: none"> Remove the fixture. Check the electrical connection, the cable and the receptacles.
	The LED has a malfunction	<ul style="list-style-type: none"> Replace the optical assy.
	Connection of the optical assy to the PCB has a malfunction.	<ul style="list-style-type: none"> Remove the optical assy. Check the electrical connections and the cable.
	The PCB has a malfunction	<ul style="list-style-type: none"> Replace the inner cover assy.
Light output too low	The prism is dirty.	<ul style="list-style-type: none"> Clean the prism.
	The LED has a malfunction.	<ul style="list-style-type: none"> Replace the optical assy.
	The PCB has a malfunction.	<ul style="list-style-type: none"> Replace the inner cover assy.

6.0 DRC/DTZ Parts

Ordering Code

D XX XXXXX0XXX0

D = AD light

Application

RC = Runway Centerline
TZ = Touchdown zone

Cord Set Style and length

A = Standard (Style 6 plugs), 10" long¹
G = German Style 1 (2-pin), 10" long¹
F = French Style 1 (3-pin), 10" long¹
J = Style 1 (2-pin) SO jacketed cable, 18" long (FAA)²
L = Style 6 (2-pin), 18" long (FAA)²

Cable and Connector

2 = 1 plug (2-pin)
3 = 2 plugs (2-pin)
4 = 1 plug (3-pin)⁸
5 = 2 plugs (3-pin)⁸

LED Color 1 – Left

W = White
R = Red³
N = Obscure / Blank (No light)³
Y = Yellow⁷

LED Color 2 – Right

W = White³
R = Red³
N = Obscure / Blank (No light)

Toe-in

0 = No toe-in
4 = Left toe-in⁴
5 = Right toe-in⁴

Dimensions

B = 8" diameter, 1/4" protrusion⁶
D = 12" diameter, 1/4" protrusion

Power Supply and Monitoring

S = Current driven, 50/60Hz, w/out monitoring
M = Current driven, 50/60Hz, with monitoring

Standards

0 = ICAO, TP 312 and FAA

Winter Options

0 = None
1 = Arctic kit
2 = Heavy-duty abrasion-resistant lens coating⁵
3 = Arctic kit and heavy-duty abrasion-resistant lens coating⁵

Bolt Holes/Fixation Options

0 = Standard (6 bolts for 12" fixture; 2 bolts/2 fixing pins for 8" fixture)
1 = 4 bolts (8" fixtures)⁶

Ground Lug Options

0 = Without ground lug⁸
U = With UL 467 ground lug (FAA standard)

Ordering Code Notes

- ¹ 8" fixtures with 10" cord sets are for installation on shallow bases and are supplied with an external O-ring gasket.
- ² Fixtures with 18" cord sets are for installation on deep base cans and are not supplied with an external O-ring gasket.
- ³ Used on runway centerline applications only.
- ⁴ Used on touchdown zone applications only.
- ⁵ Typically used for intensive winter service where sand is applied to runways and rotating brushes are used.
- ⁶ Fixture can be used with an optional 12" snow plow ring adapter: Part No. AW5008ADB11E (bidirectional) or AW5008ADB1E (unidirectional).
- ⁷ To be used with RETIL applications. Not ETL Certified.
- ⁸ Not ETL Certified.

Figure 12: 12" DRC or DTZ Light Fixture Assembly

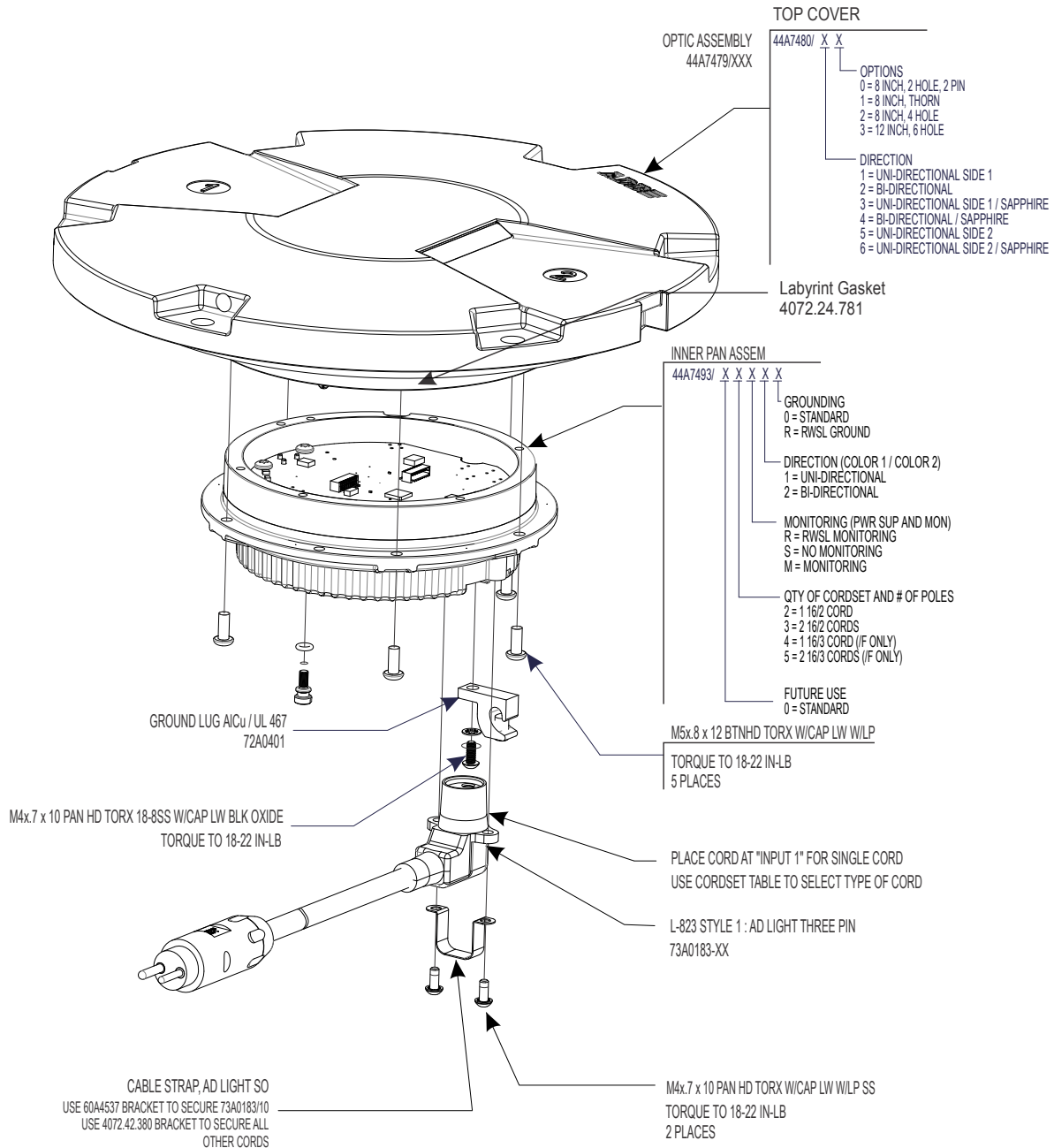
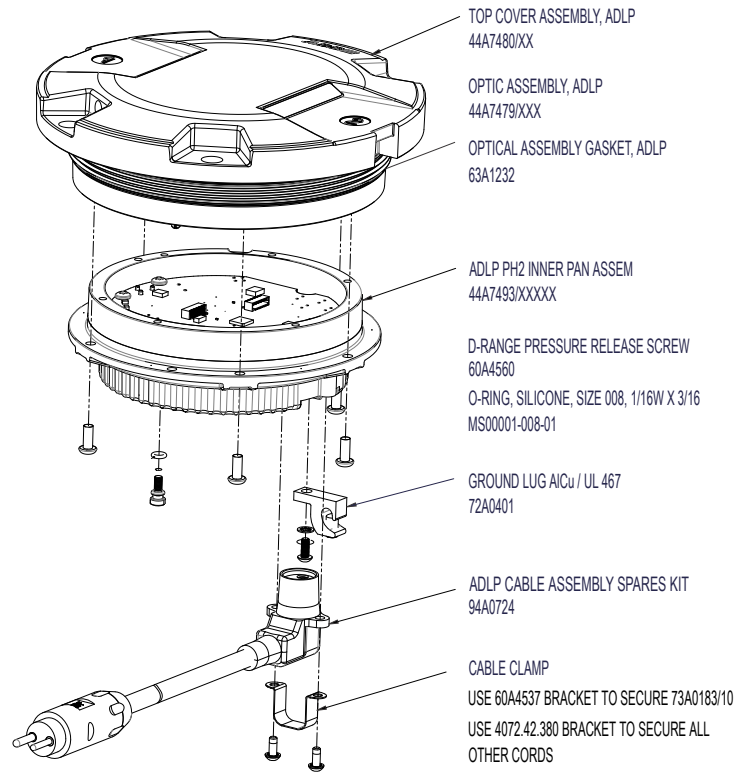

Figure 13: 8" DRC or DTZ Light Fixture Assembly



CORDSET TABLE		
LOCAL VERSION	CORDSET DESCRIPTION	PART NUMBER
A	ADB STYLE 6 WITH 10" CORD	4072.24.950
G	GERMAN (STYLE 1 PLUGS AND NAMEPLATE)	4072.24.730
F	FRENCH (3 POLE PLUGS AND PRISM PROTECTION)	4072.24.770
L	FAA (STYLE 6 PLUGS WITH 18" WIRES)	4072.42.350
J	FAA STYLE 1 SOOW JACKETED	73A0183/10

STANDARD ADLP RWSL HARDWARE SPARES KIT 94A0725 IS REQUIRED
FOR ALL SPARE REPLACEMENTS EXCEPT CABLE SPARE KIT 94A0724

Table 6: DRC-LP and DTZ-LP Light Spare Parts

Order Code	Description	DRC Monitored	DRC Unmonitored	DTZ Monitored	DTZ Unmonitored	Notes
44A7479-XXXX	LED Assembly	1	1	1	1	See Manual
44A7480-XX	Top Cover 8"	1	1	1	1	See Manual
44A7493-XXXX	ADLP Pan Assembly	1	1	1	1	See Manual
63A1232	ADLP Optical Assembly Gasket	1	1	1	1	
60A4537	ADLP SOOW Cable Clamp	1 or 2	1 or 2	1	1	FAA Jacketed Cordset Clamp
4072.42.380	ADLP Cable Clamp (non-jacketed)	1 or 2	1 or 2	1	1	Non-jacketed Cordset Clamp

Table 6: DRC-LP and DTZ-LP Light Spare Parts (Continued)

Order Code	Description	DRC Monitored	DRC Unmonitored	DTZ Monitored	DTZ Unmonitored	Notes
73A0183-10	Jacketed Style 1 Cordset 18 inch (450 mm)	1 or 2	1 or 2	1	1	
4072.24.770	French Style 10" Cordset (250 mm)	1 or 2	1 or 2	1	1	
4072.24.951	Non-FAA Cordset 10" (250 mm)	1 or 2	1 or 2	1	1	
60A4560	Pressure Release Screw	1	1	1	1	
7080.90.012	O-Ring	2	2	2	2	
RWSL Kits						
44A7480/XX	Top Cover Assembly					
44A7479/XXXX	Optic Assembly					
44A7493/XXXXX	Bottom Pan Assembly					
94A0724	RWSL Cable Assembly Spares Kit					
94A0725	ADLP RWSL Hardware Spares Kit					

Figure 14: Top Cover Assembly ADLP 44A7480-XX

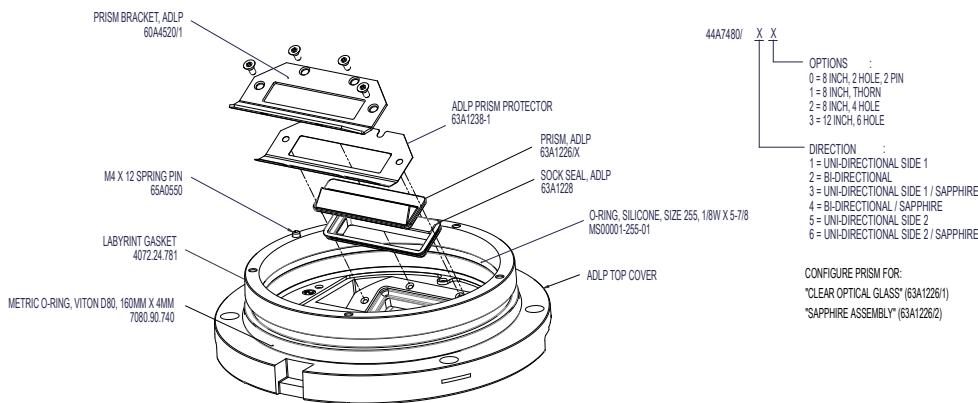
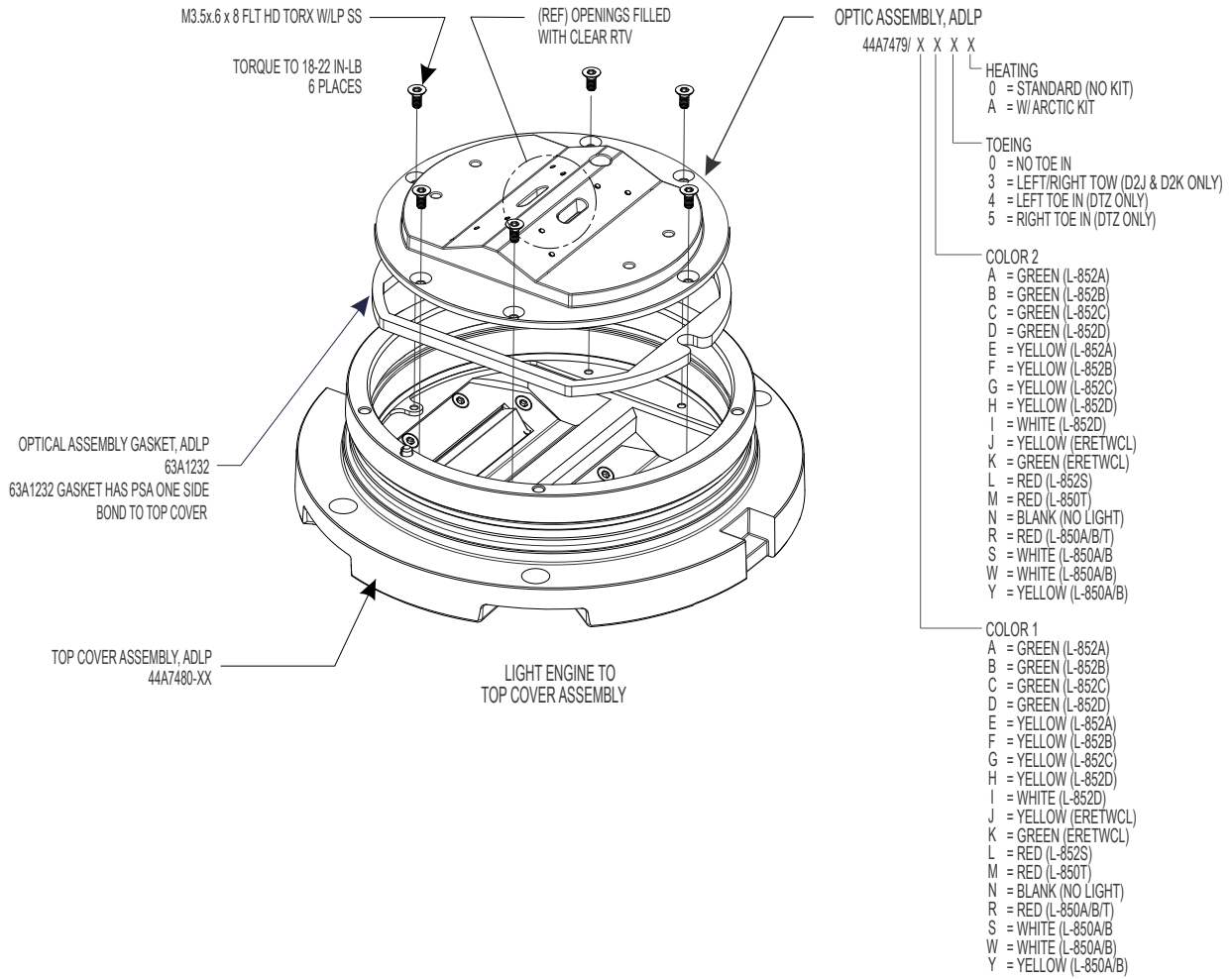

Figure 15: Light Assembly to Top CoverTI



Appendix A: SUPPORT

Our experienced engineers are available for support and service at all times, 24 hour/7 days a week. They are part of a dynamic organization making sure the entire ADB SAFEGATE is committed to minimal disturbance for airport operations.

ADB SAFEGATE Support

Live Technical Support - Americas

If at any time you have a question or concern about your product, just contact ADB SAFEGATE's technical service department. Trained in all areas of system issues, troubleshooting, quality control and technical assistance, our highly experienced Technical support specialists are available 24 hours a day, seven days a week to provide assistance over the phone.

ADB SAFEGATE **Americas Technical Service & Support (US & Canada): +1-800-545-4157**

ADB SAFEGATE Americas Technical Service & Support (International): +1-614-861-1304

During regular business hours, you can also Chat with a Service Technician. We look forward to working with you!

Before You Call

When you have an airfield lighting or system control system problem it is our goal to support airfield maintenance staff as quickly as possible. To support this effort we ask that you have the following information ready before calling.

- The *airport code*
- If not with an airport, then company name (prefer customer id number)
- Contact phone number and email address
- Product with part number preferable or product number
- Have you reviewed the product's manual and troubleshooting guide
- Do you have a *True RMS* meter available (and any other necessary tools)
- Be located with the product ready to troubleshoot

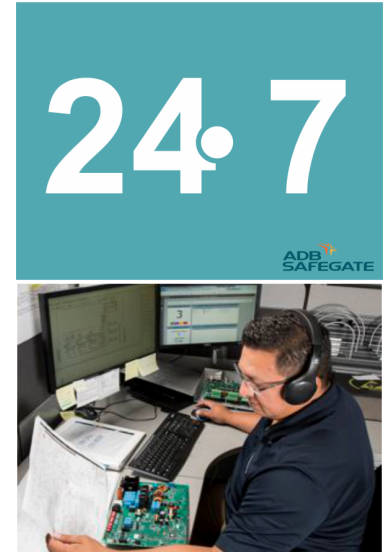

Note

For more information, see www.adbsafegate.com, or contact ADB SAFEGATE Support via email at support@adbsafegate.com or

Brussels: +32 2 722 17 11

Rest of Europe: +46 (0) 40 699 17 40

Americas: +1 614 861 1304. Press 3 for technical service or press 4 for sales support.

China: +86 (10) 8476 0106

A.1 ADB SAFEGATE Website

The ADB SAFEGATE website, www.adbsafegate.com, offers information regarding our airport solutions, products, company, news, links, downloads, references, contacts and more.

A.2 Recycling

A.2.1 Local Authority Recycling

The disposal of ADB SAFEGATE products is to be made at an applicable collection point for the recycling of electrical and electronic equipment. The correct disposal of equipment prevents any potential negative consequences for the environment and human health, which could otherwise be caused by inappropriate waste handling. The recycling of materials helps to conserve natural resources. For more detailed information about recycling of products, contact your local authority city office.

A.2.2 ADB SAFEGATE Recycling

ADB SAFEGATE is fully committed to environmentally-conscious manufacturing with strict monitoring of our own processes as well as supplier components and sub-contractor operations. ADB SAFEGATE offers a recycling program for our products to all customers worldwide, whether or not the products were sold within the EU.

ADB SAFEGATE products and/or specific electrical and electronic component parts which are fully removed/separated from any customer equipment and returned will be accepted for our recycling program.

All items returned must be clearly labeled as follows:

- For *ROHS/WEEE* Recycling
- Sender contact information (Name, Business Address, Phone number).
- Main Unit Serial Number.

ADB SAFEGATE will continue to monitor and update according for any future requirements for *EU directives* as and when *EU member states* implement new *regulations* and or *amendments*. It is our aim to maintain our *compliance plan* and assist our customers.

Company Addresses

ADB SAFEGATE	ADB SAFEGATE, Belgium: Leuvensesteenweg 585, B-1930 Zaventem Belgium
Contact: Tel.: +32 2 722 17 11, Fax: +32 2 722 17 64	Email: marketing@adbsafegate.com Internet: www.adbsafegate.com
Americas LLC	ADB SAFEGATE, Americas: 977 Gahanna Parkway, Columbus, OH 43230 USA
Contact: Tel.: +1 (614) 861 1304, Fax: +1 (614) 864 2069	Email: sales.us@adbsafegate.com Internet: www.adbsafegate.com
ADB SAFEGATE Sweden AB	ADB SAFEGATE, Sweden: Djurhagegatan 19 SE-213 76 Malmö Sweden
Contact: Tel.: +46 (0)40 699 17 00, Fax: +46 (0)40 699 17 30	Email: marketing@adbsafegate.com Internet: www.adbsafegate.com
ADB SAFEGATE Airfield Technologies Ltd. China	ADB SAFEGATE, China: Unit 603, D Block, CAMIC International Convention Center, No 3, Hua Jia Di East road, ChaoYang district, Beijing 100102 P.R. China
Contact: Tel.: +86 (10) 8476 0106, Fax: +86 (10) 8476 0090	Email: china@safegate.com Internet: www.adbsafegate.com
ADB SAFEGATE Germany GmbH	ADB SAFEGATE Germany GmbH, Mannheim: Konrad-Zuse-Ring 6, D-68163 Mannheim Germany
Contact: Tel.: +49 (621) 87 55 76-0, Fax: +49 (621) 87 55 76-55	Email: marketing@adbsafegate.com Internet: www.adbsafegate.com



Powering Your Airport Performance from Approach to Departure

adbsafegate.com

Copyright © ADB SAFEGATE, all rights reserved

